

Schlachtschiff **Bismarck** 1940



HMV

HAMBURGER MODELLBAUBOGEN VERLAG

© 2000 Scheuer & Ströver GmbH

moduni.de

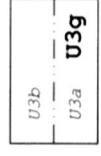
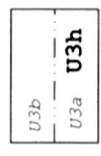
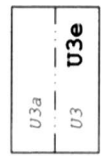
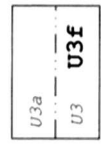
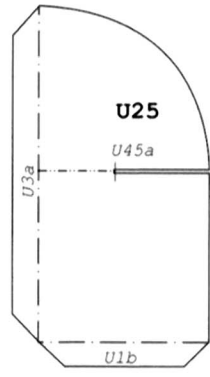
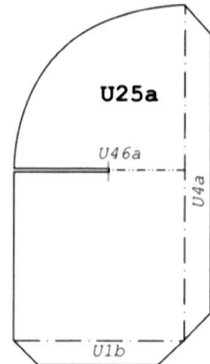
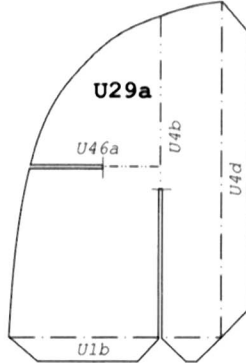
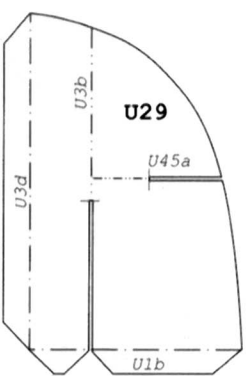
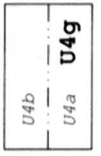
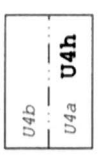
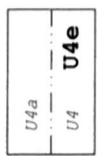
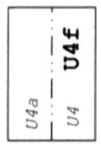
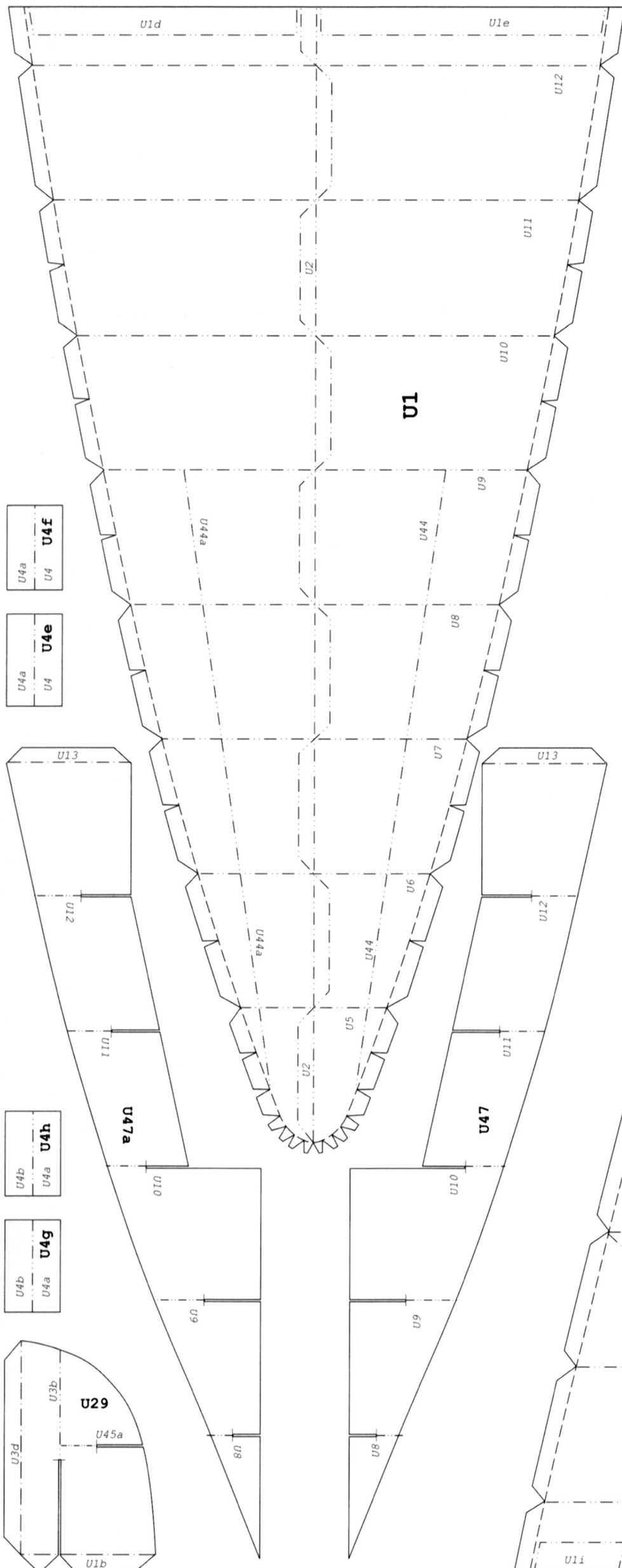

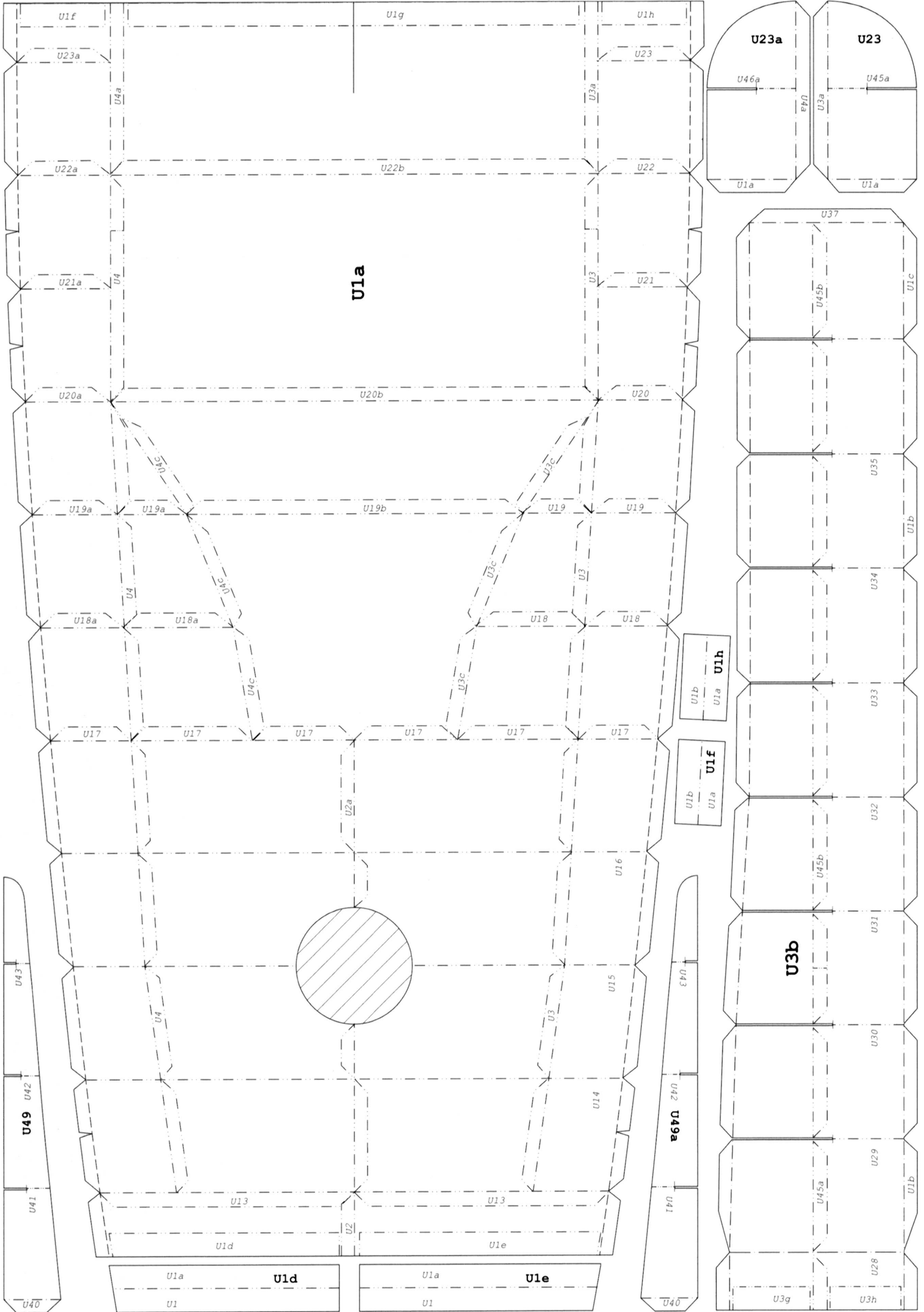

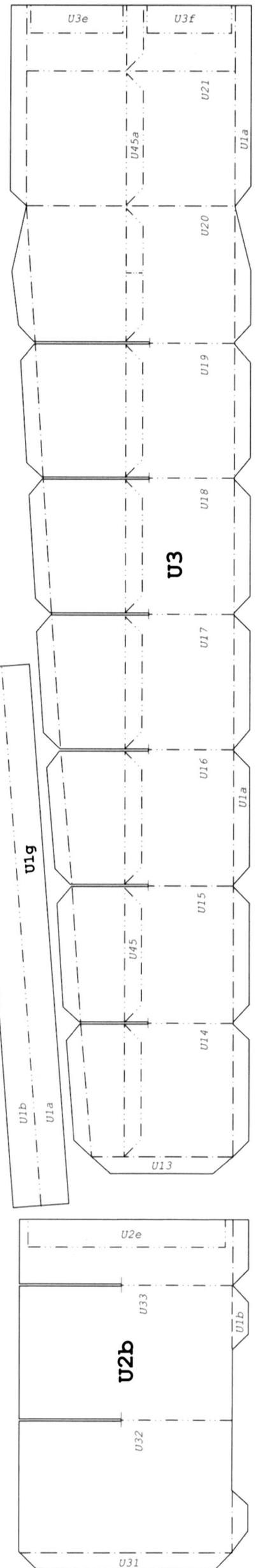
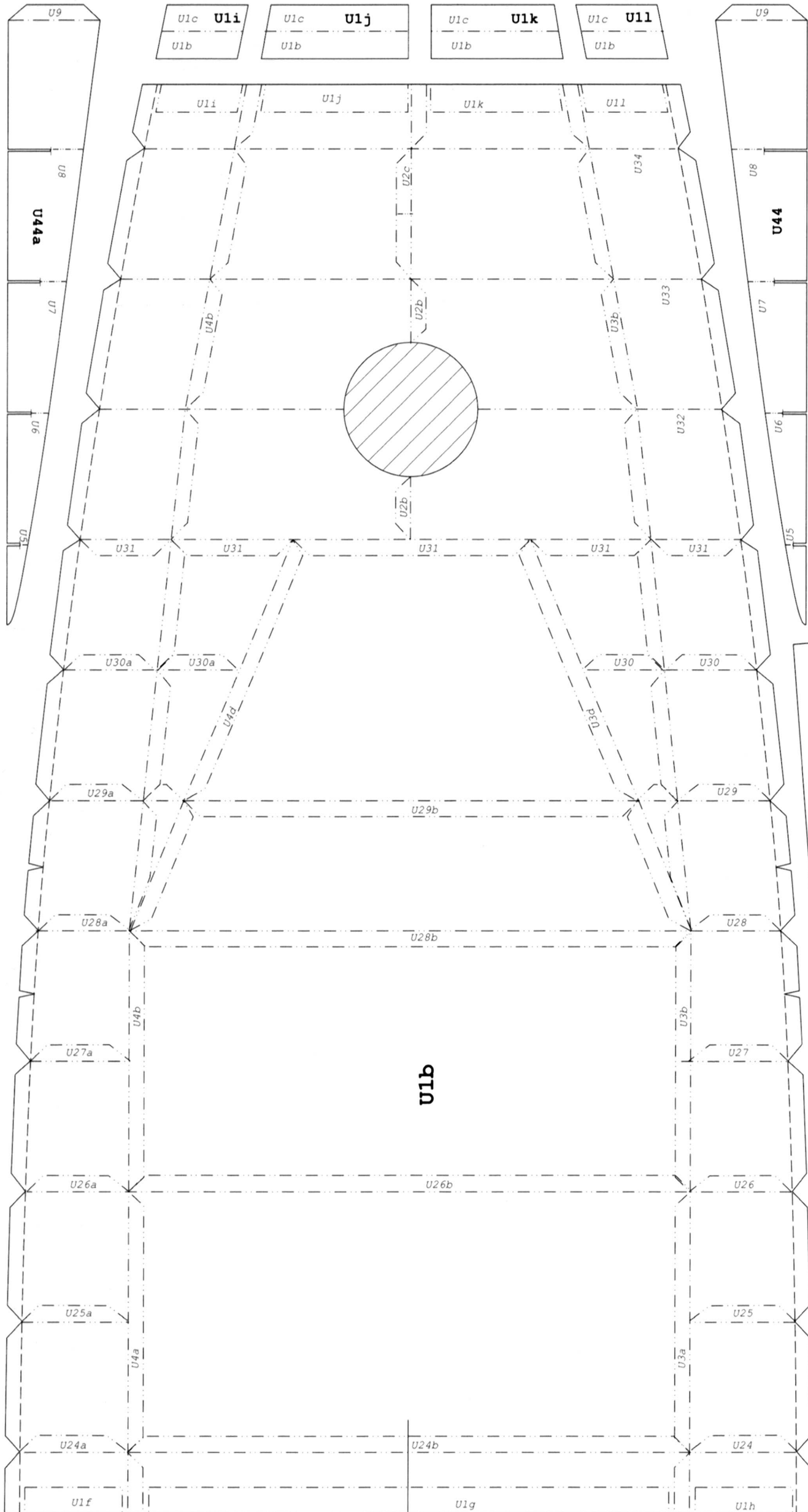

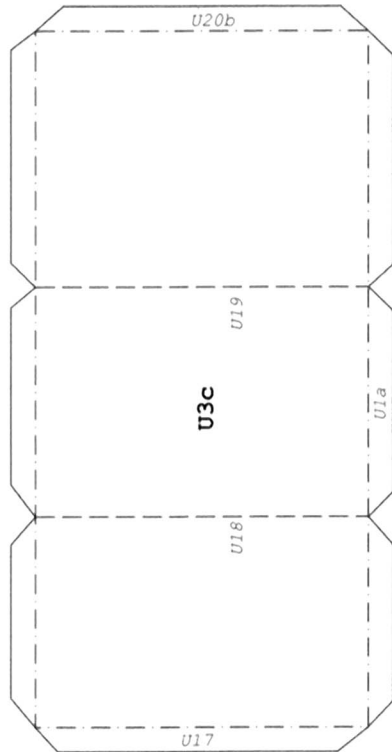
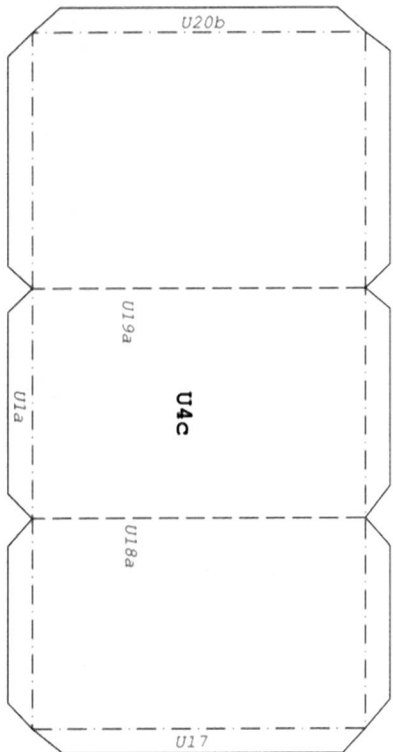
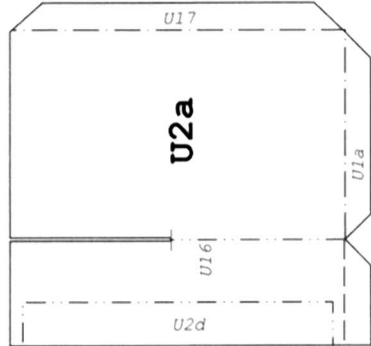
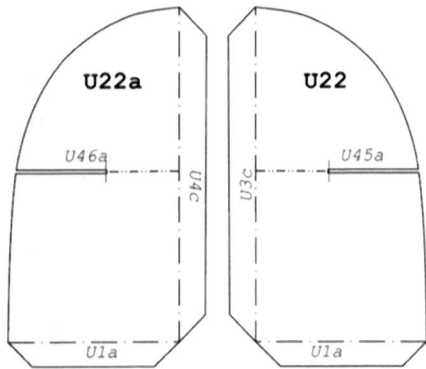
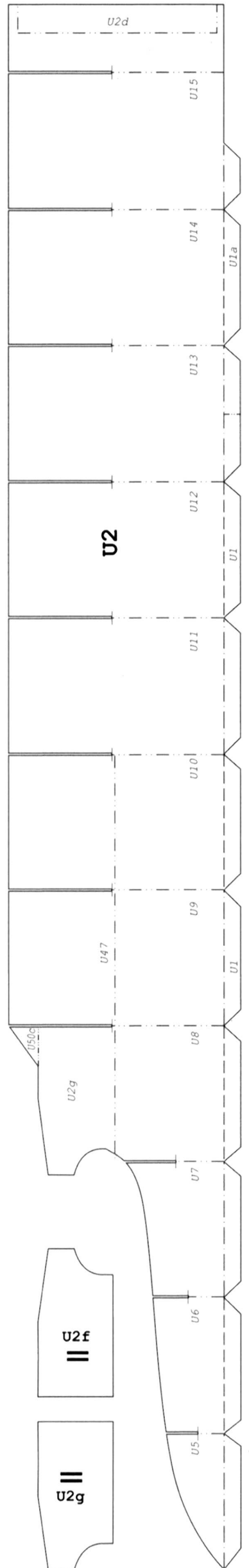
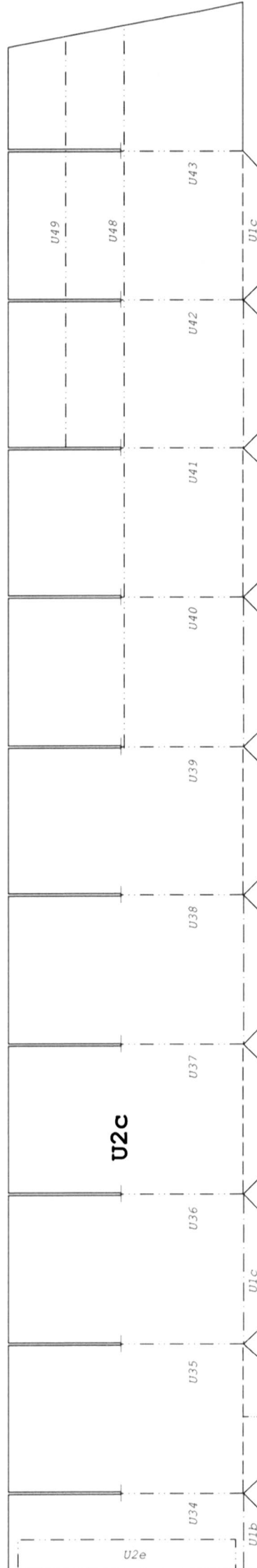
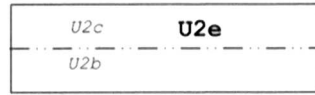
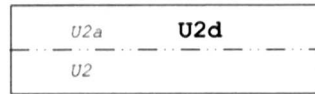
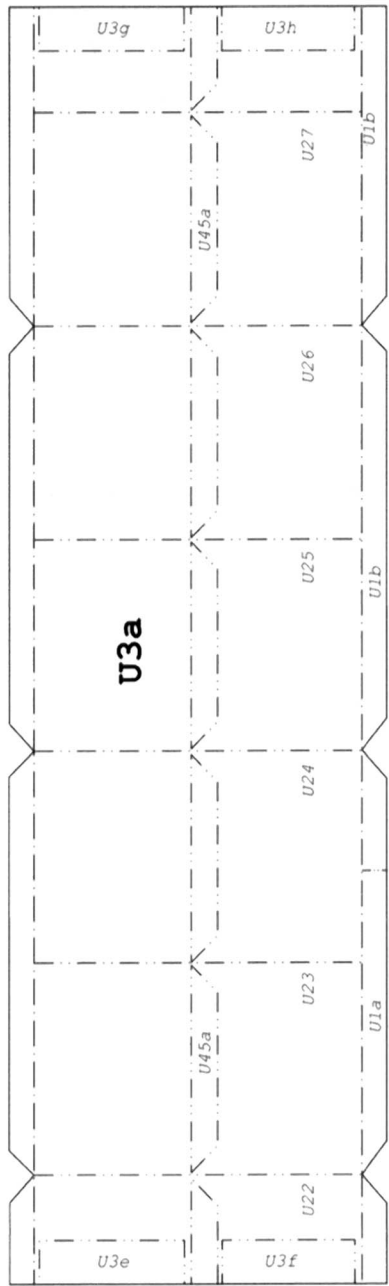
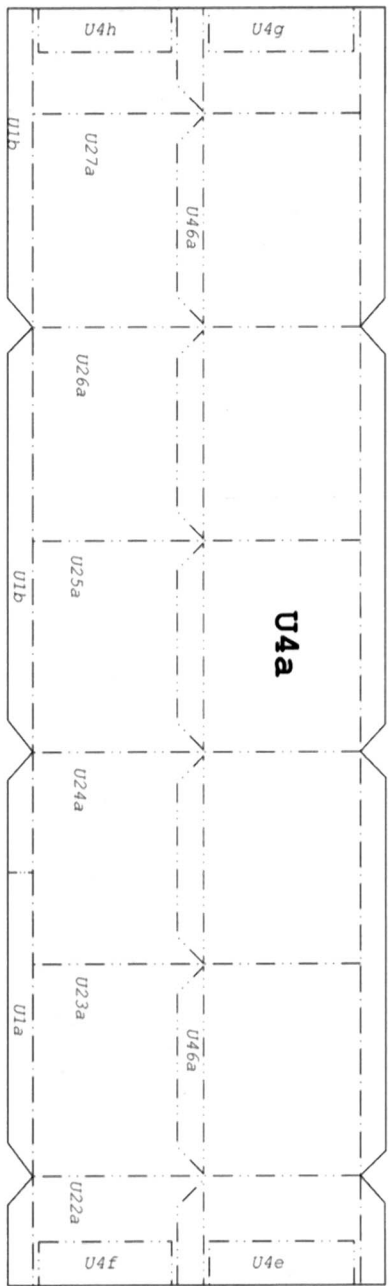

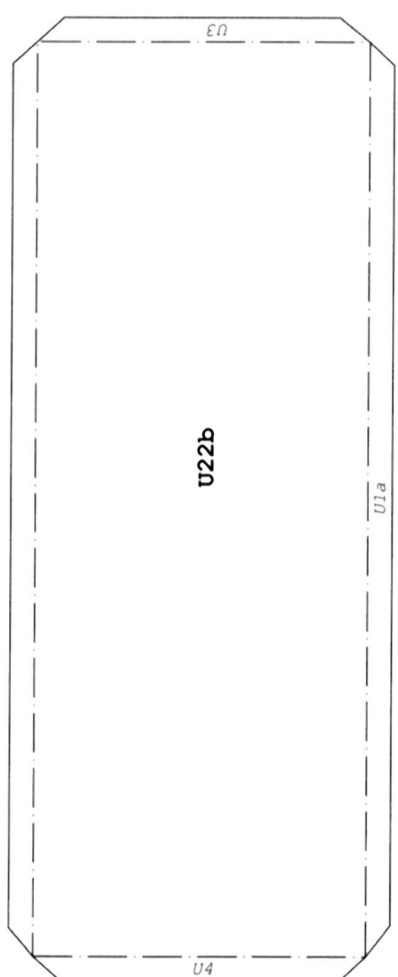
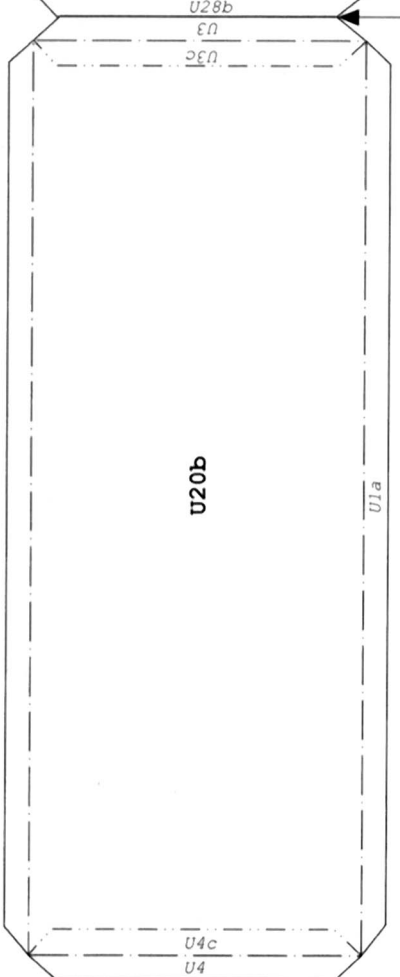
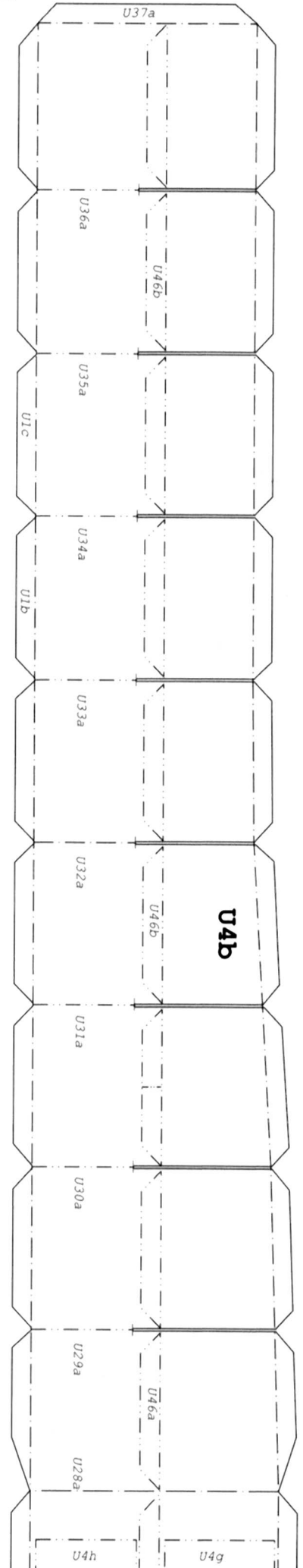
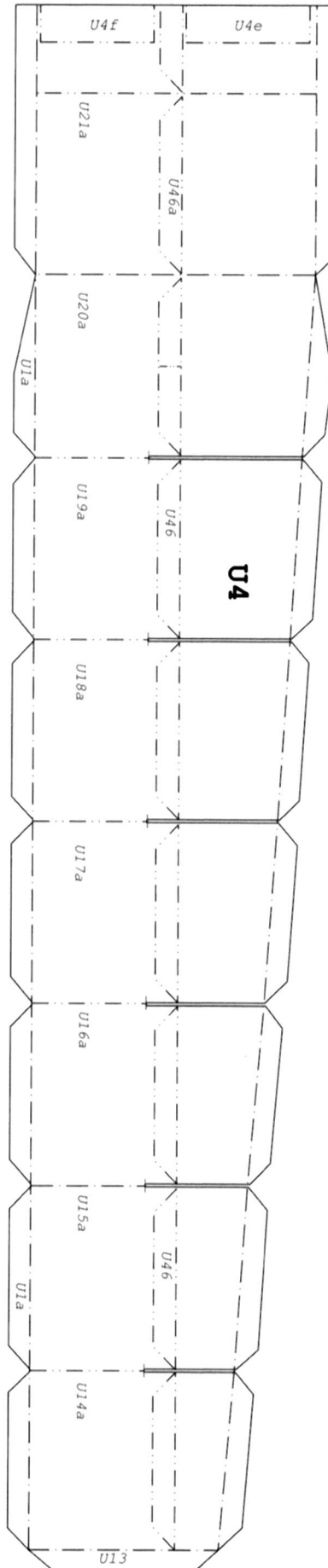
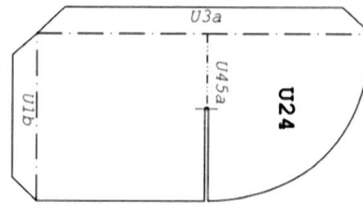
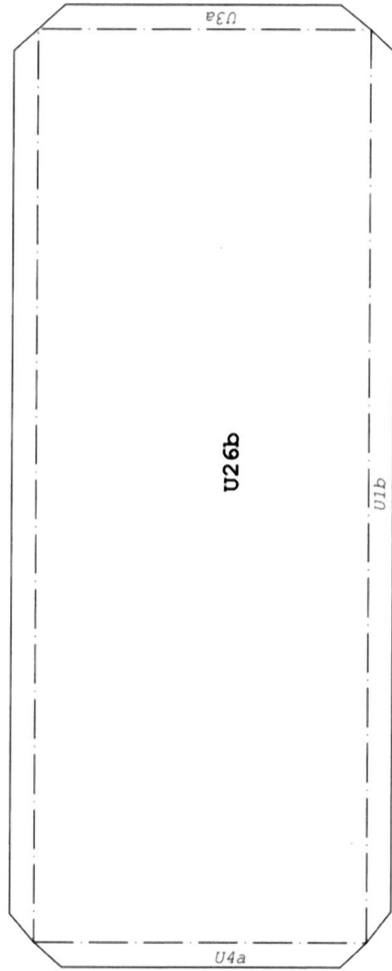
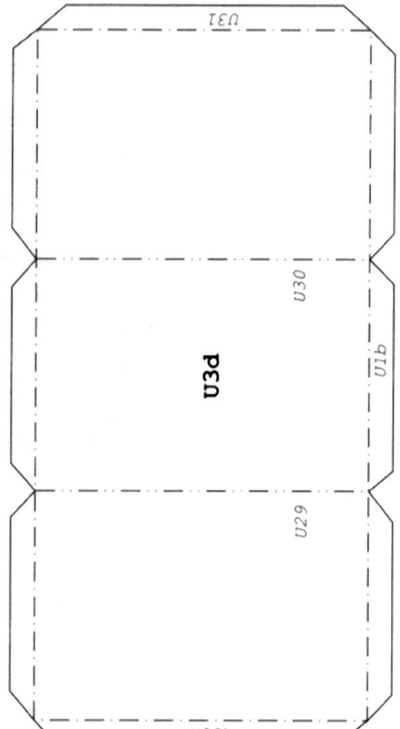
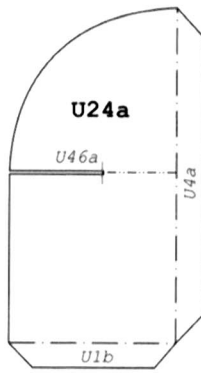
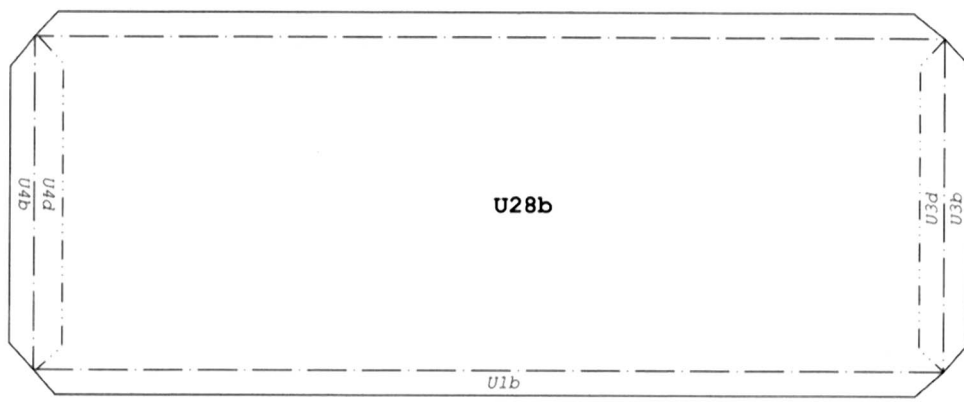
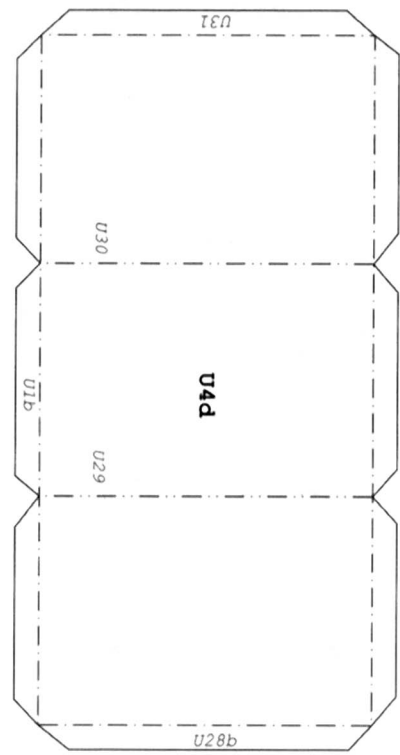

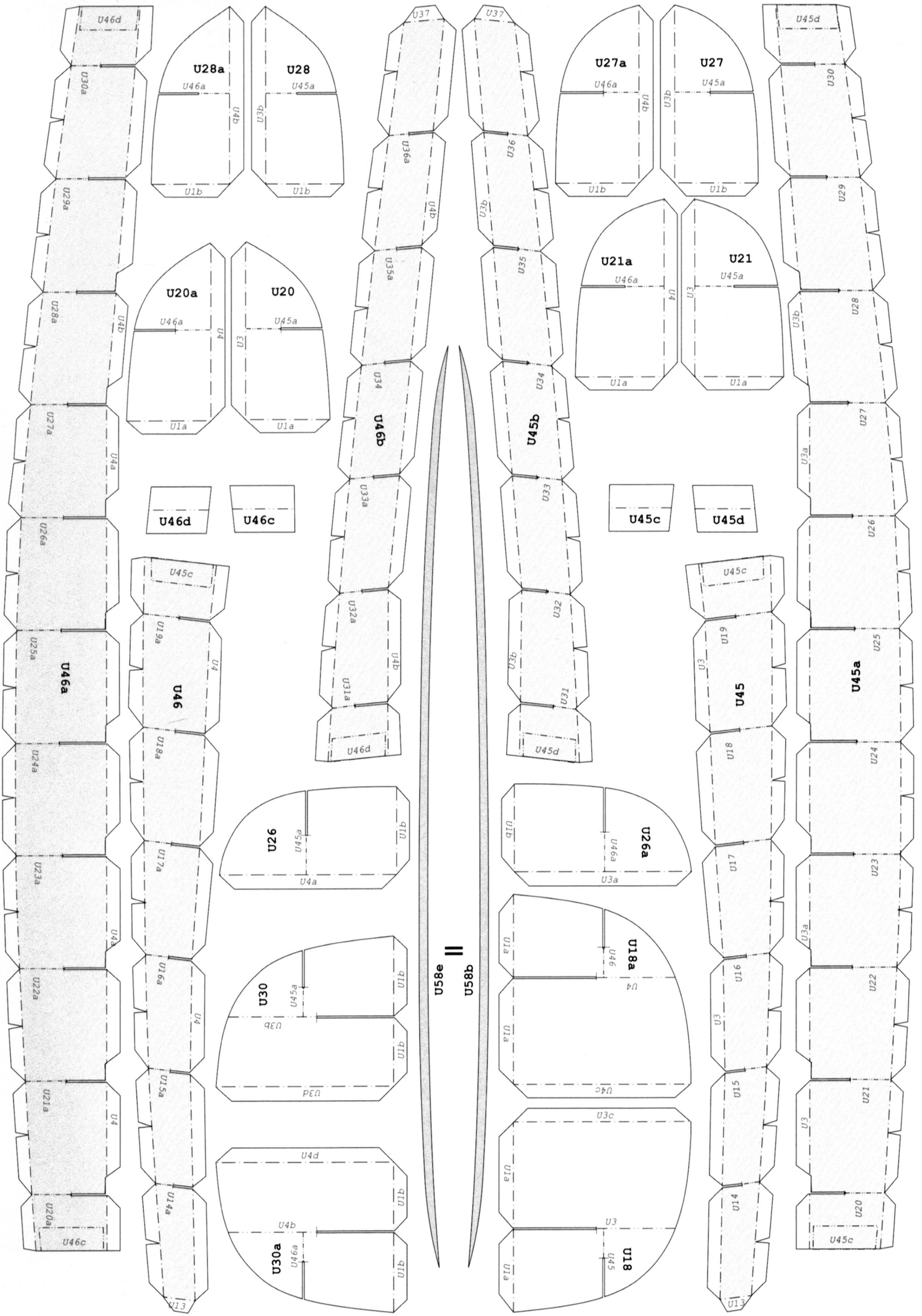

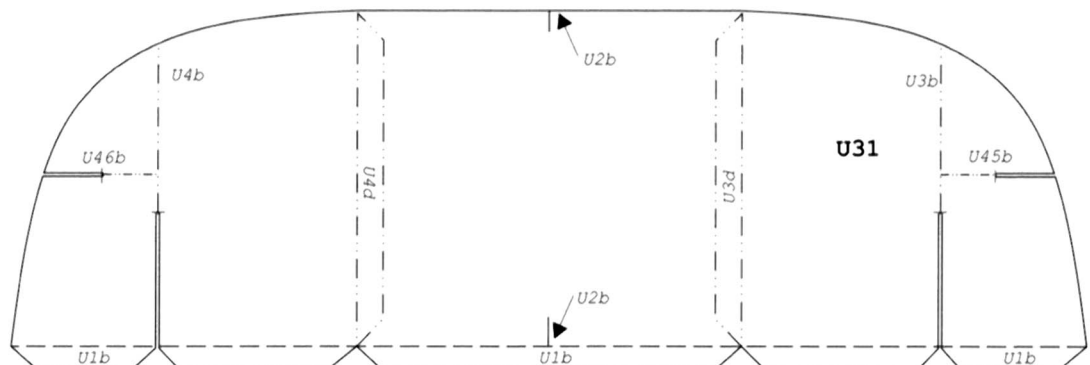
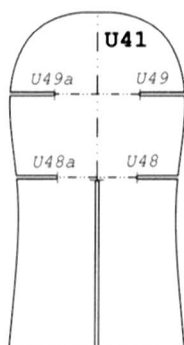
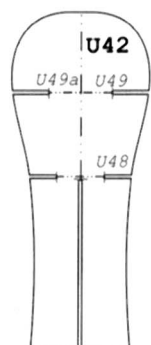
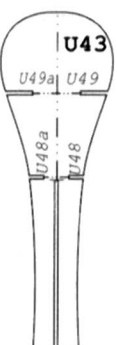
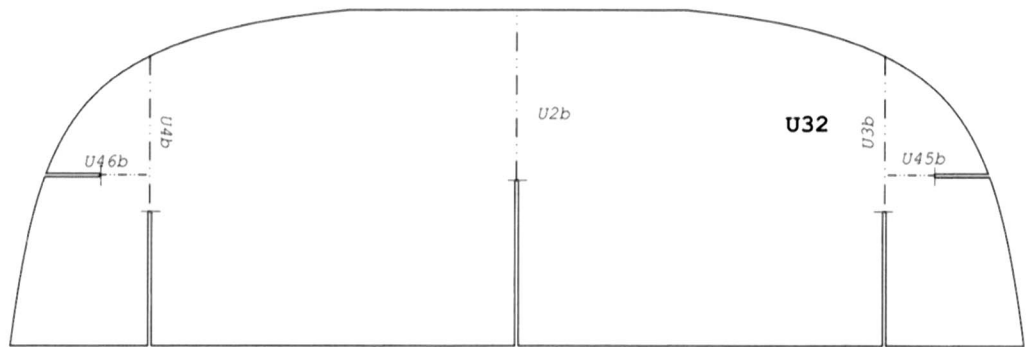
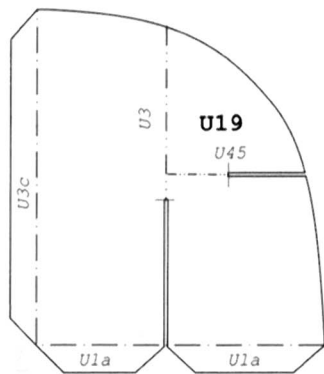
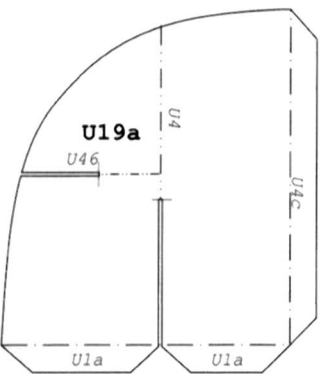
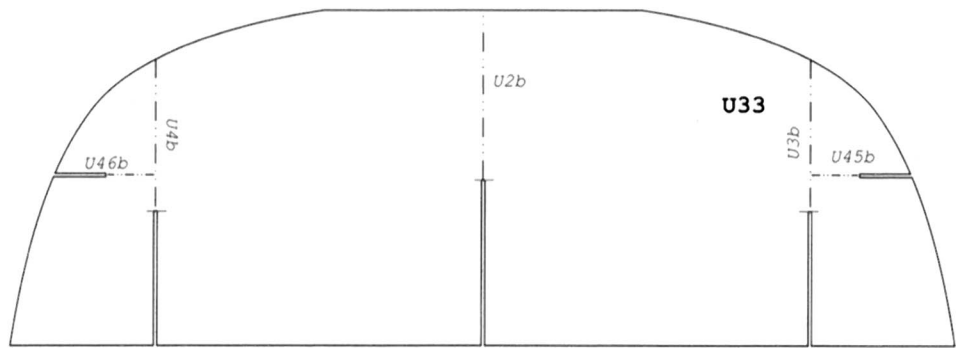
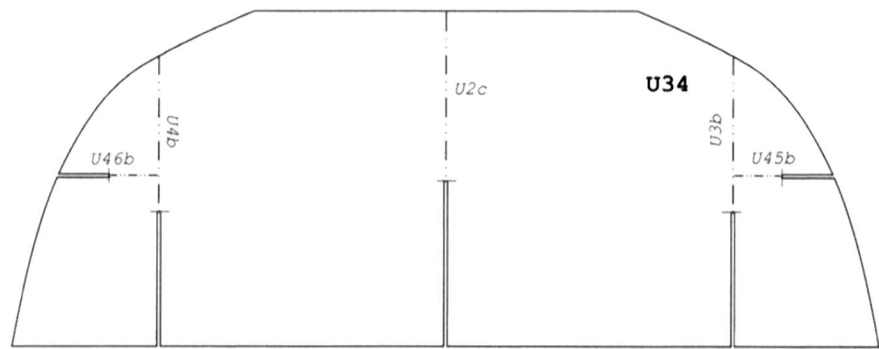
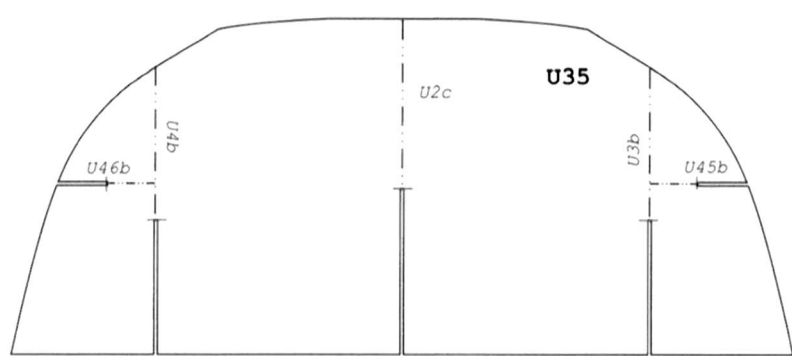
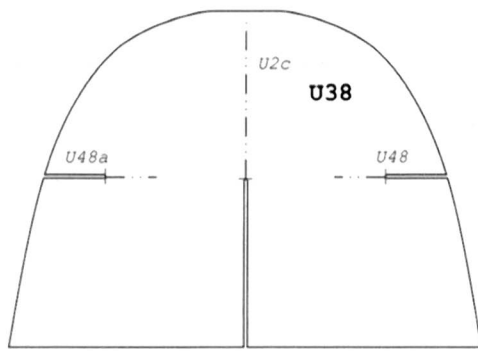
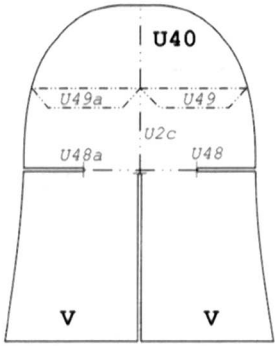
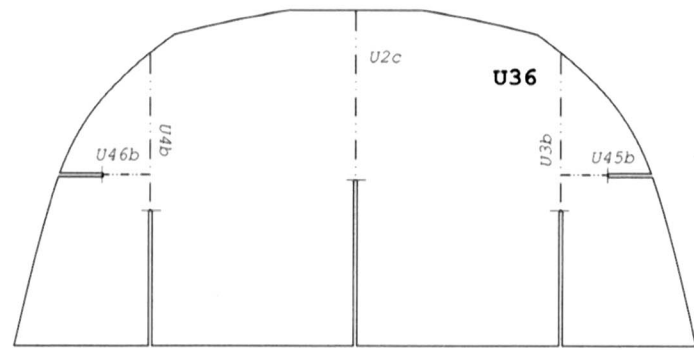
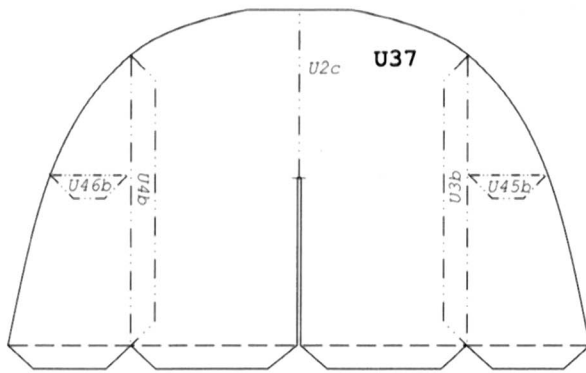
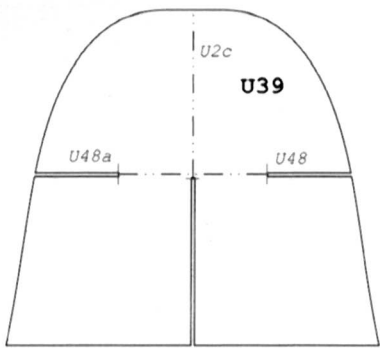

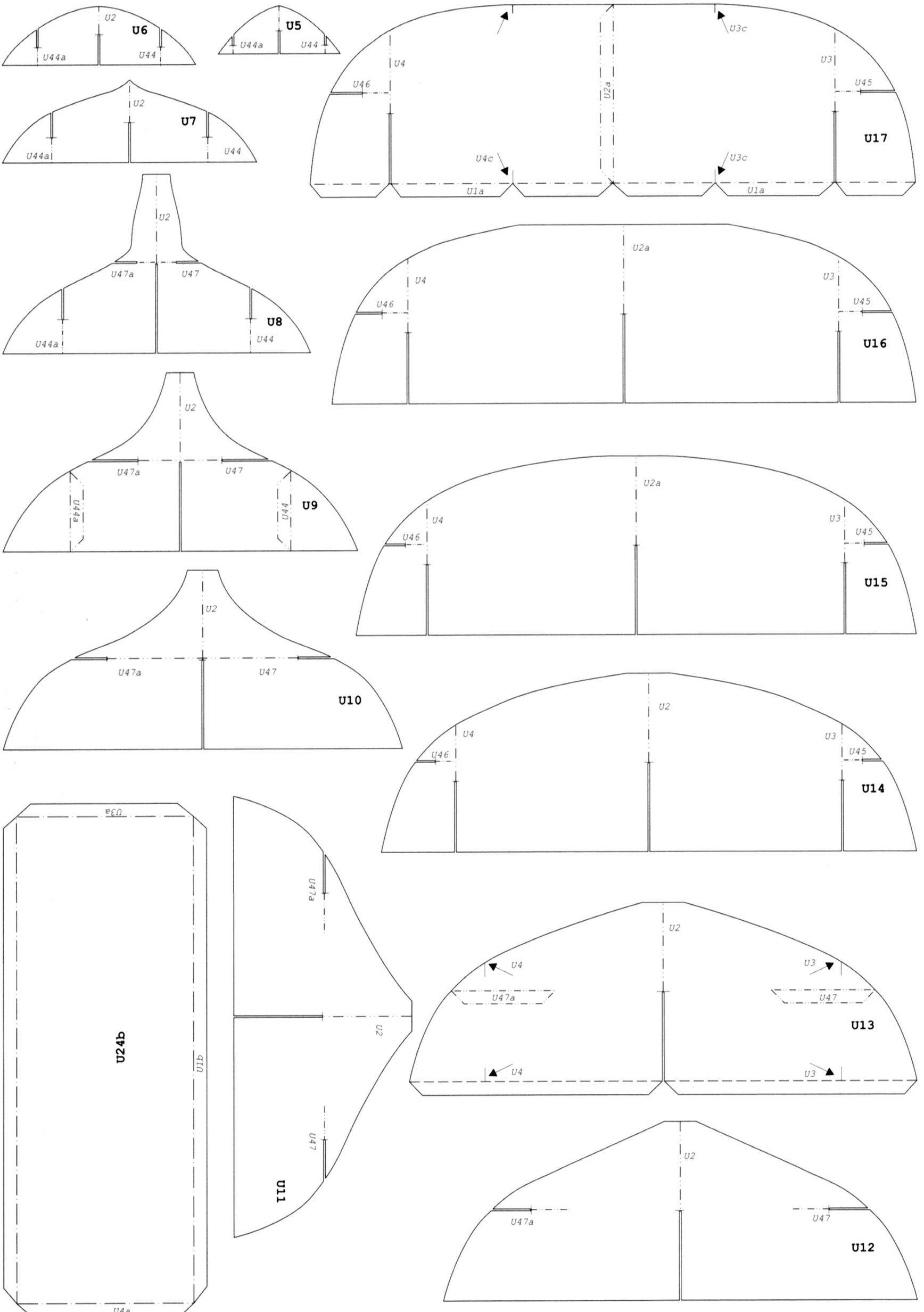

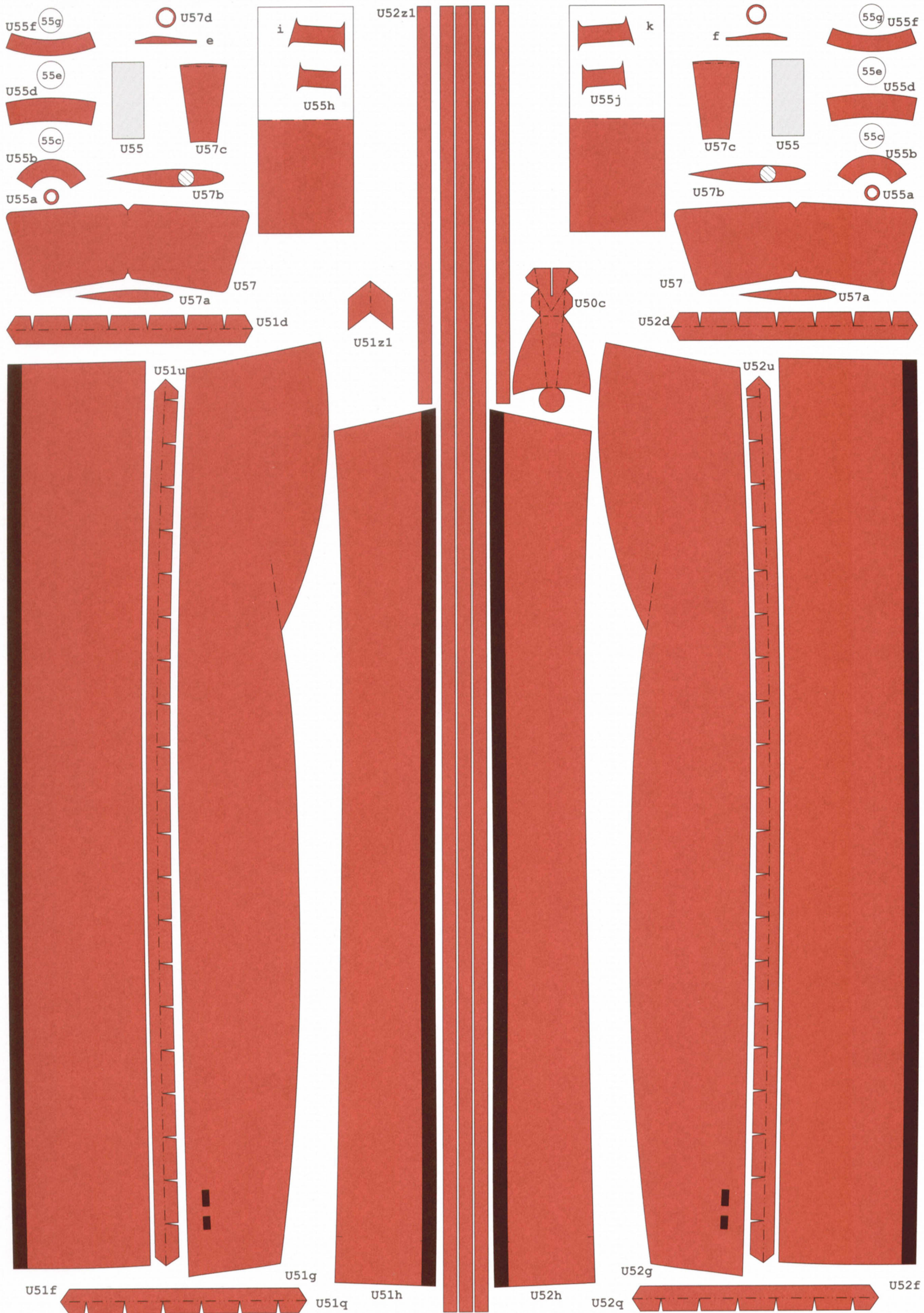

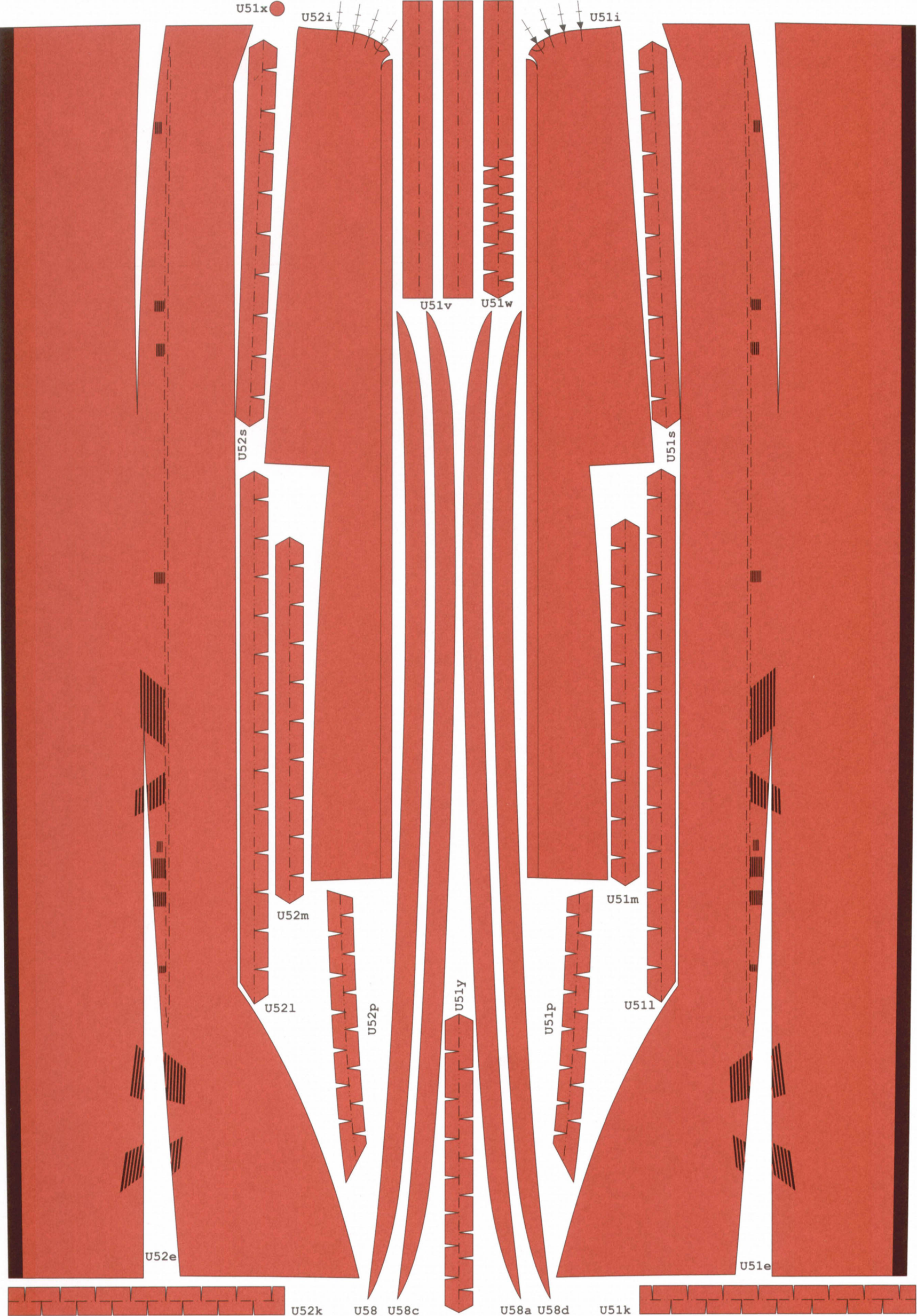

U51x ●

U52i

U51i

U51v

U51w

U52s

U51s

U52m

U51m

U521

U52p

U51y

U51p

U511

U52e

U51e

U52k

U58

U58c

U51y

U58a

U58d

U51k

U51j H

H U52j

U51t

U52t

U52c

U51c

U54a

U53a

U51

U51o

U51a

U54b

U54

U52b

U53

U51b

U53b

U52o

U52

U52a



Reserve

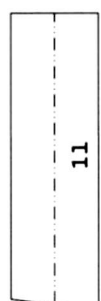
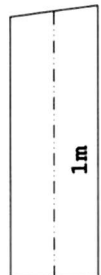
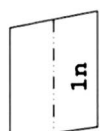
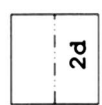
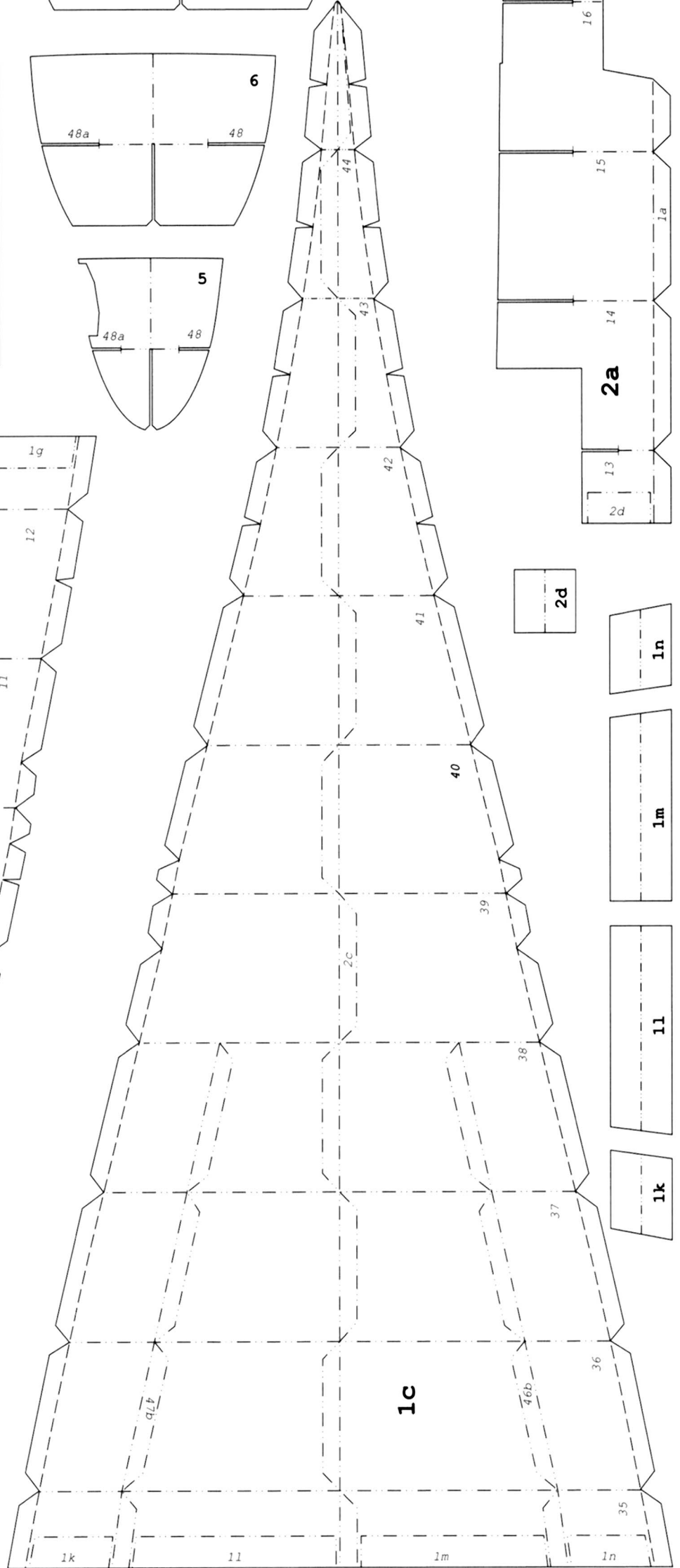
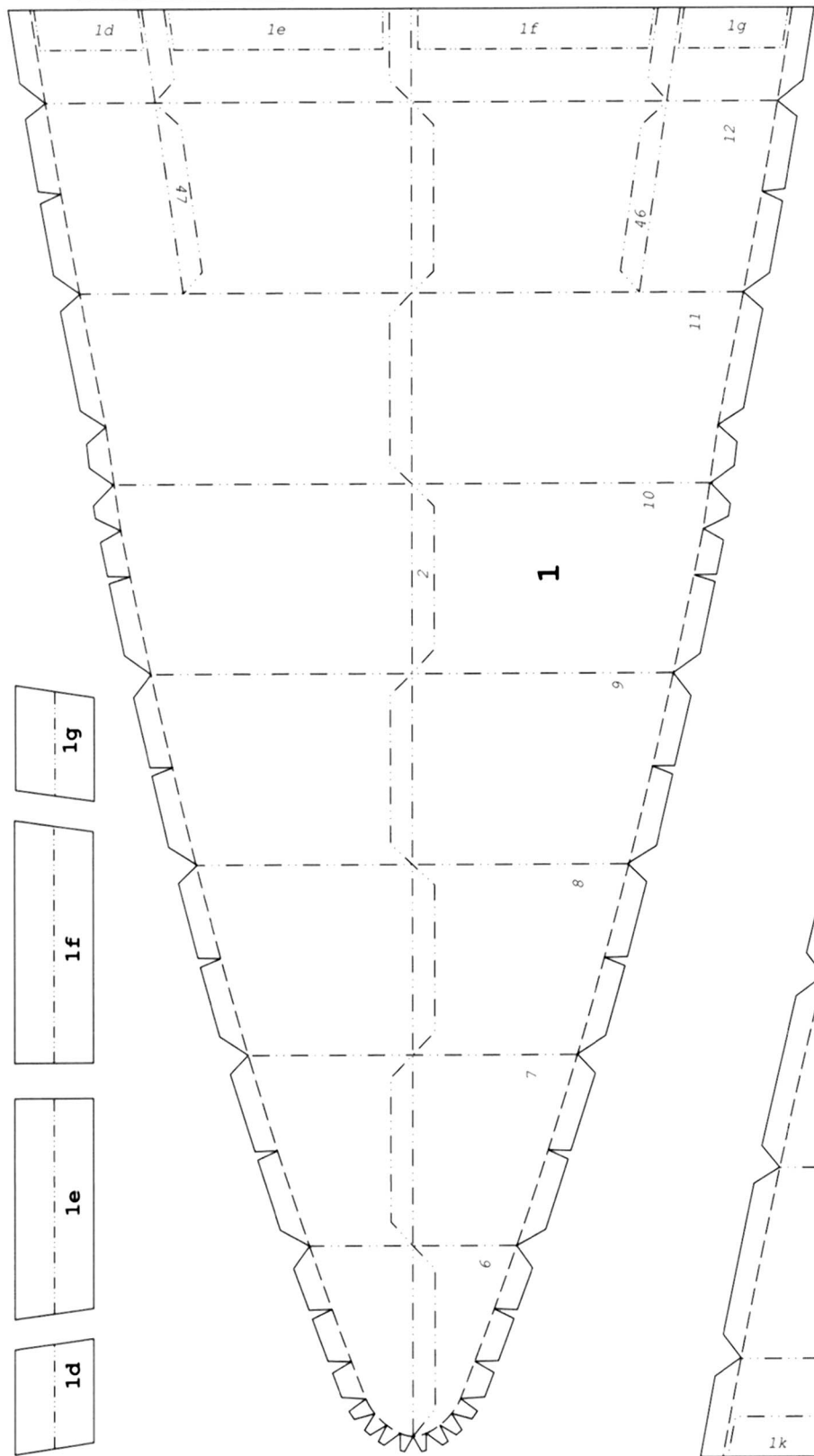
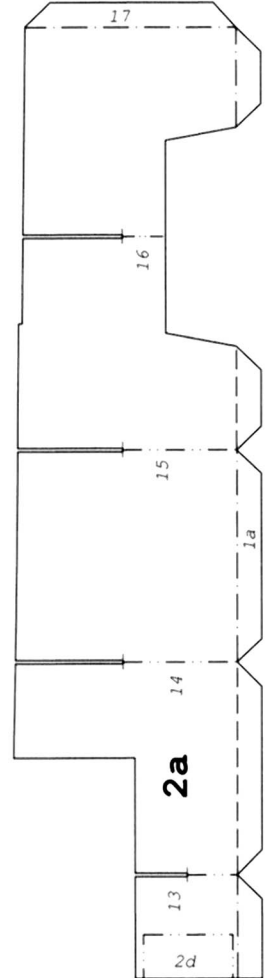
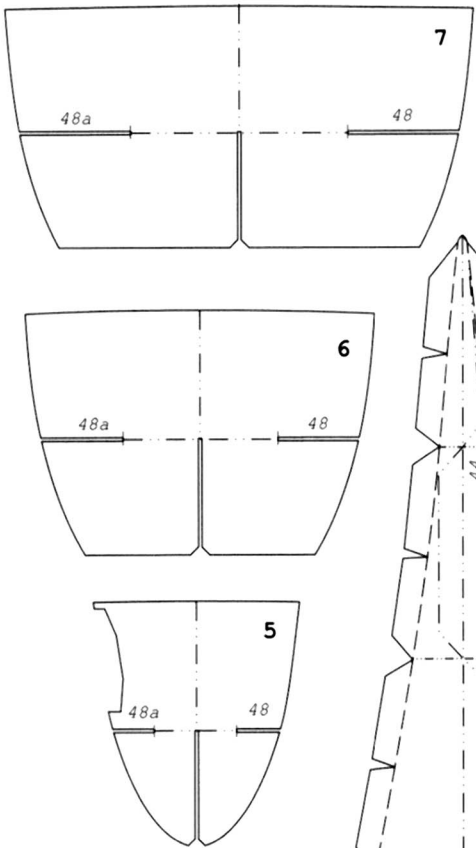
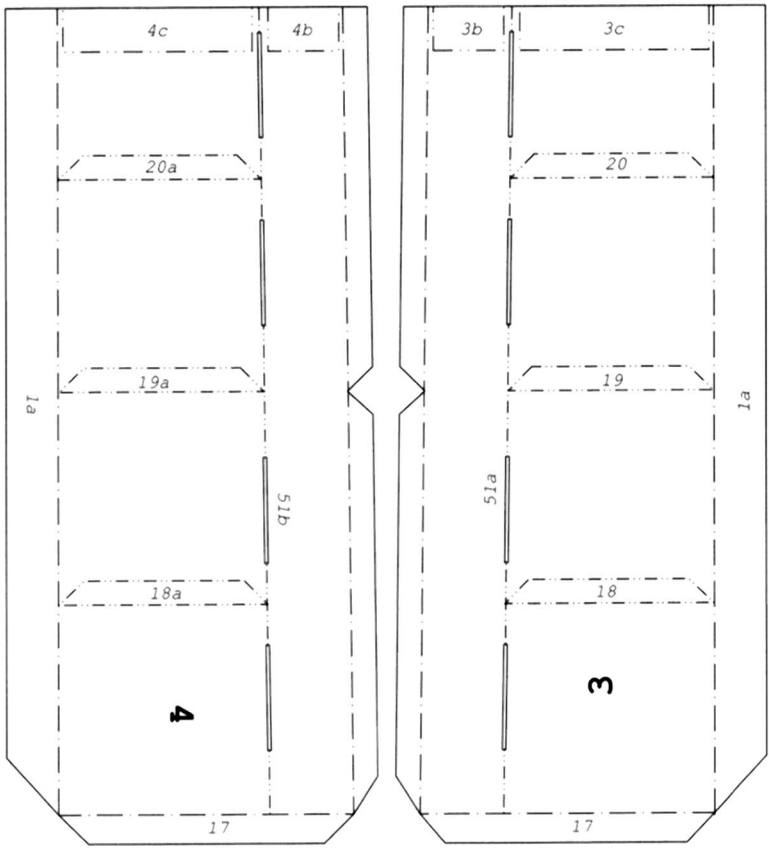

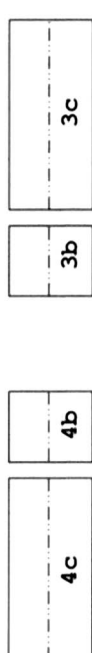
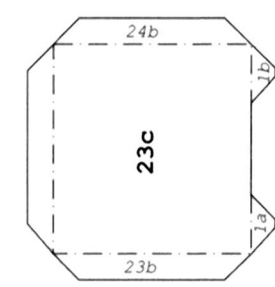
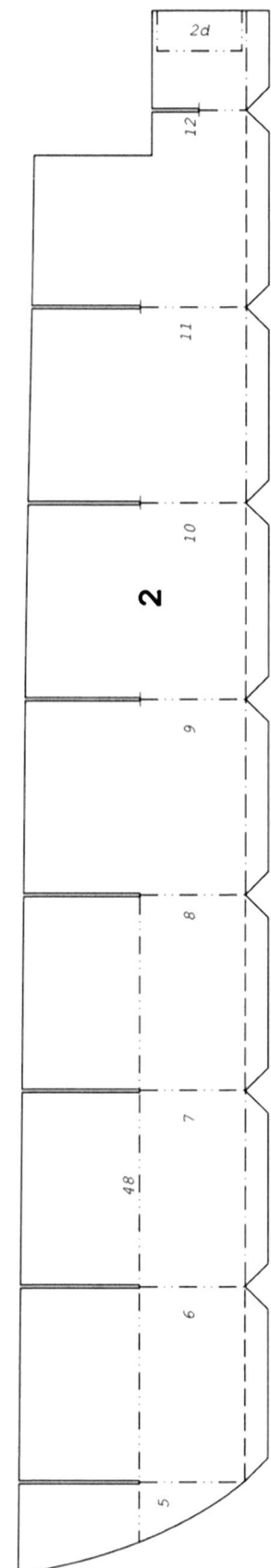
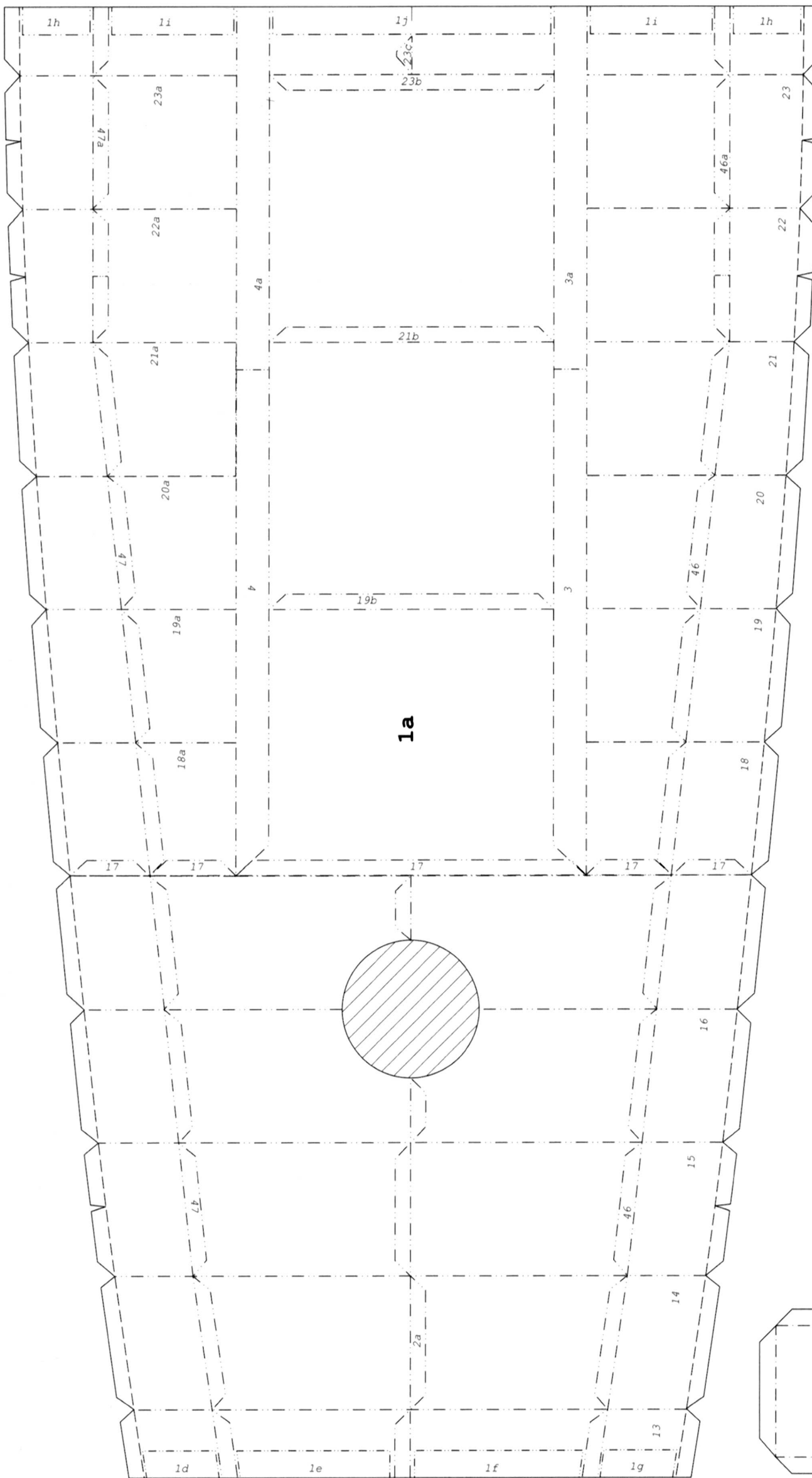

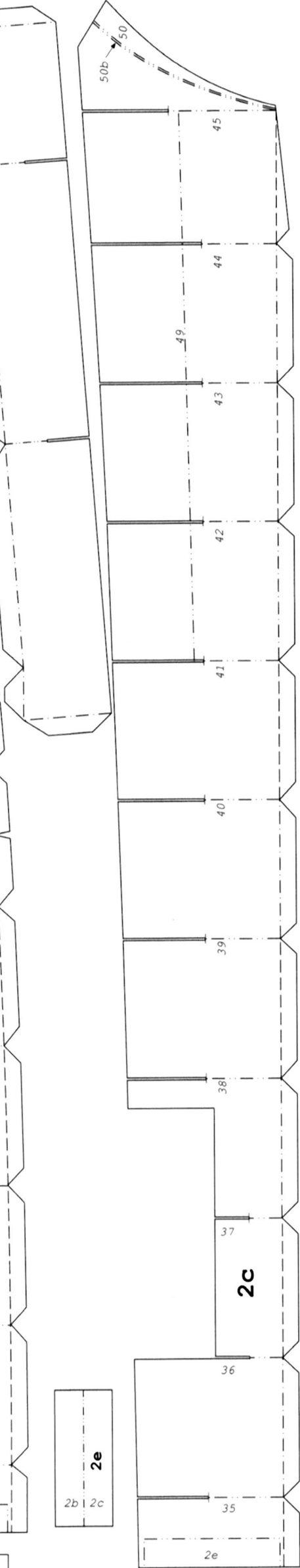
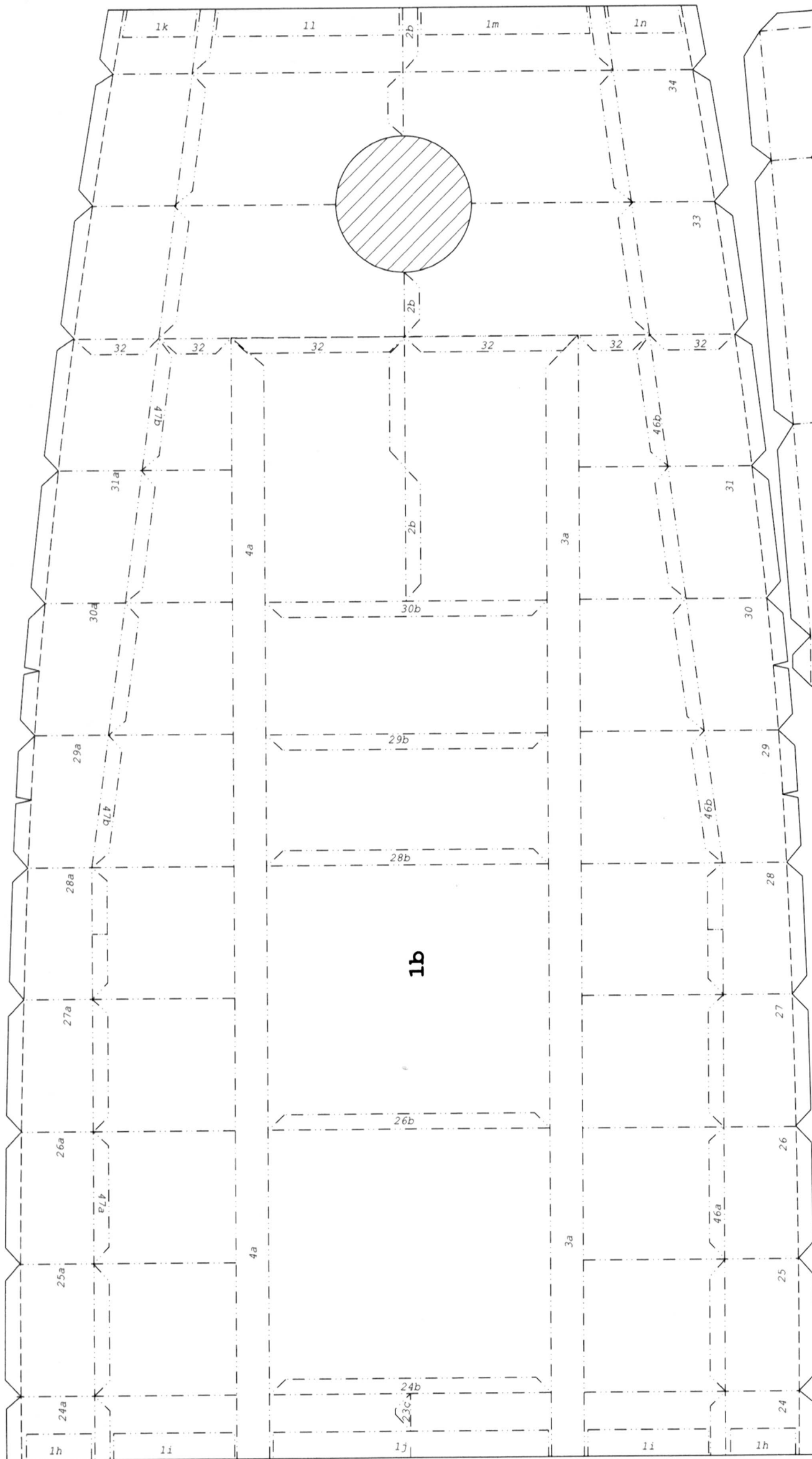

1b
1a 1h

1b
1a 1i

1b
1a 1j

1b
1a 1i

1b
1a 1h

2e
2b 2c

2e
35
36

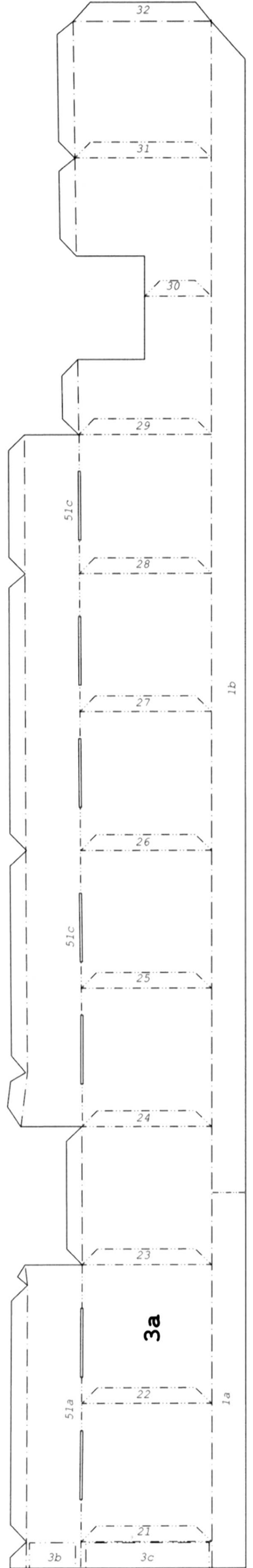
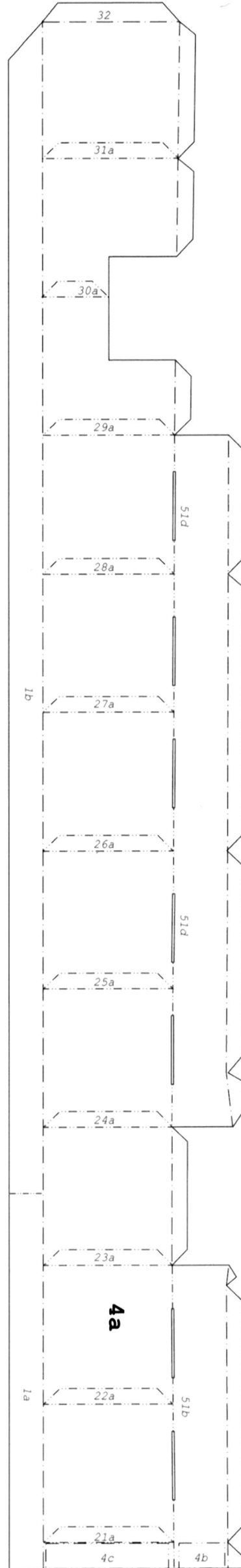
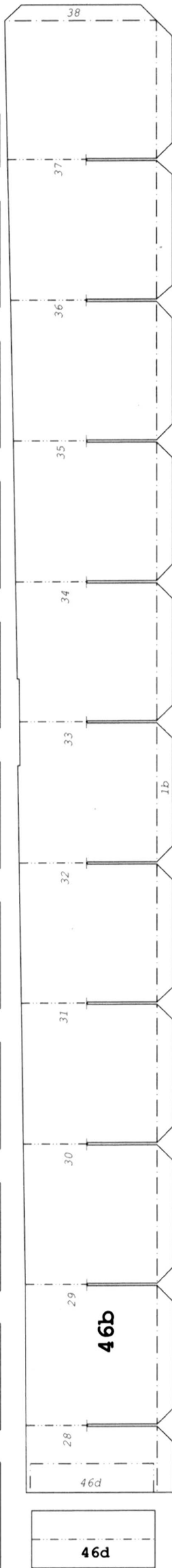
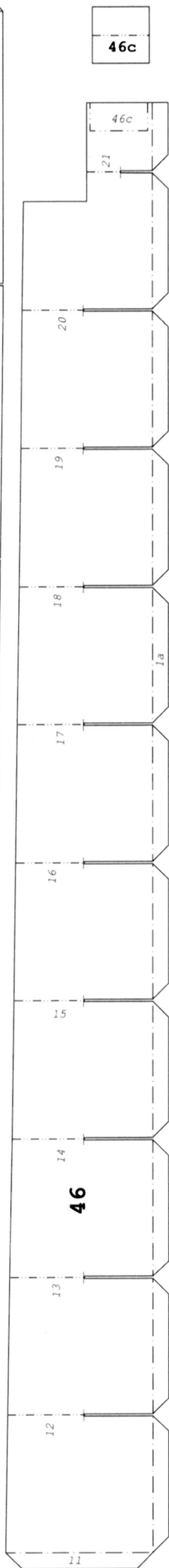
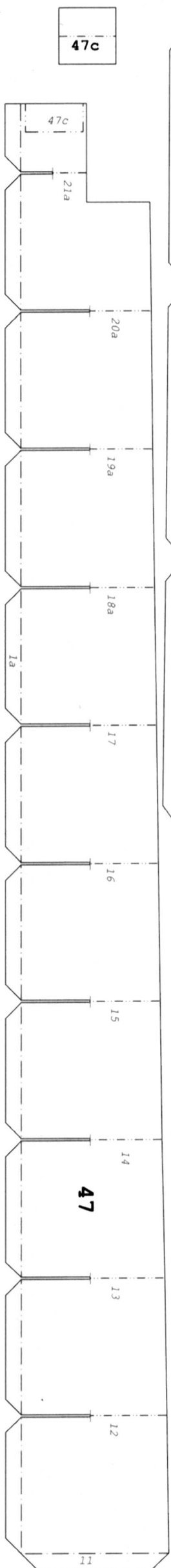

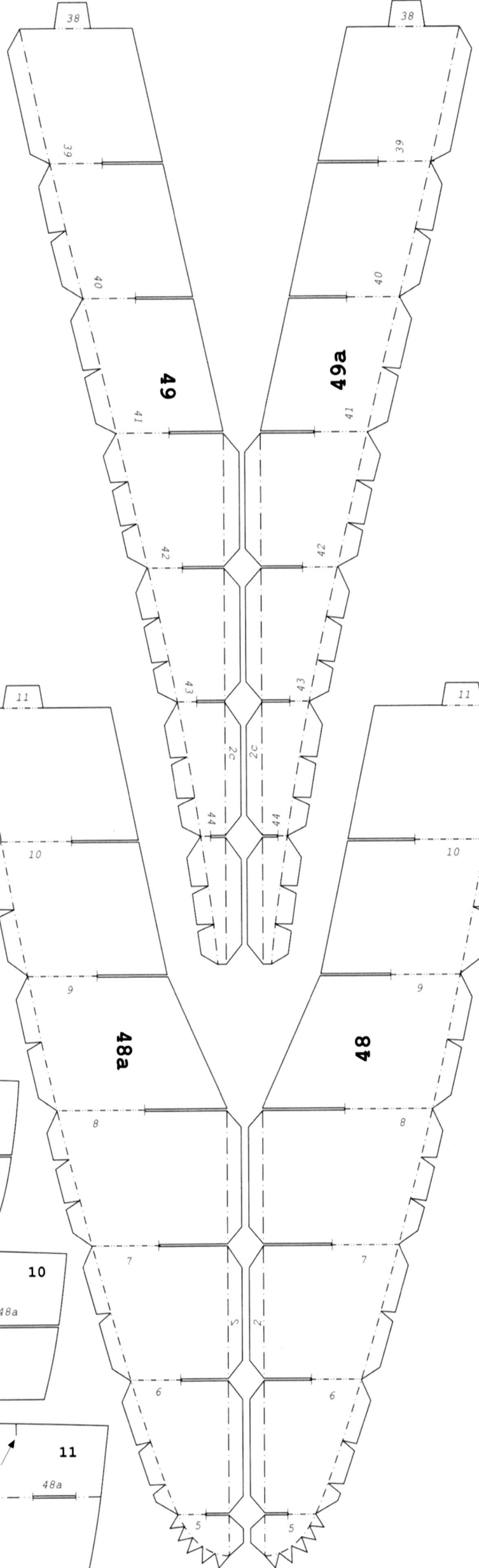
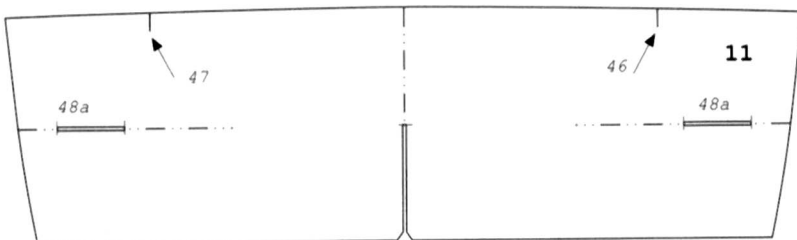
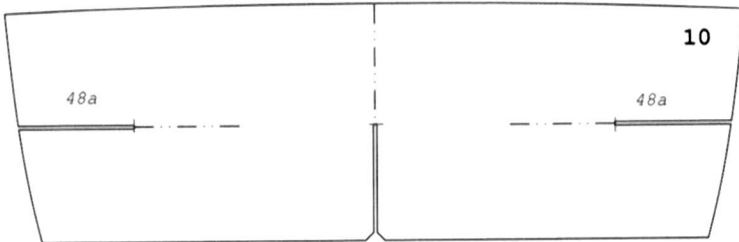
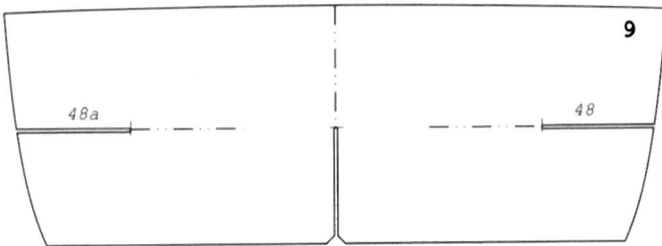
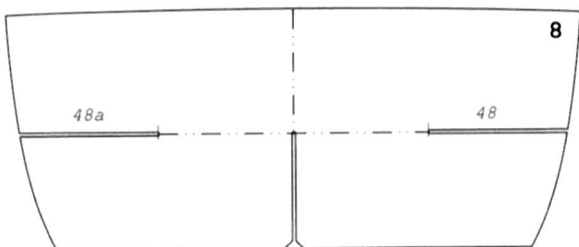
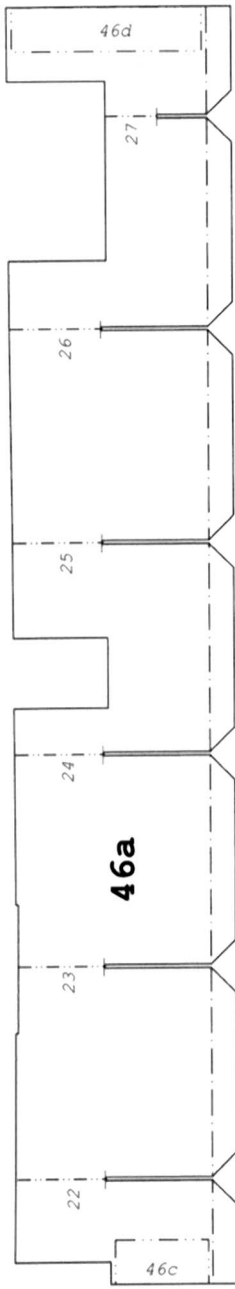
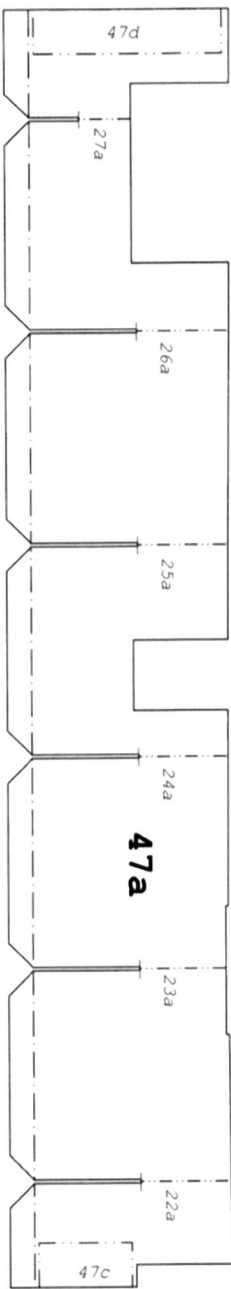
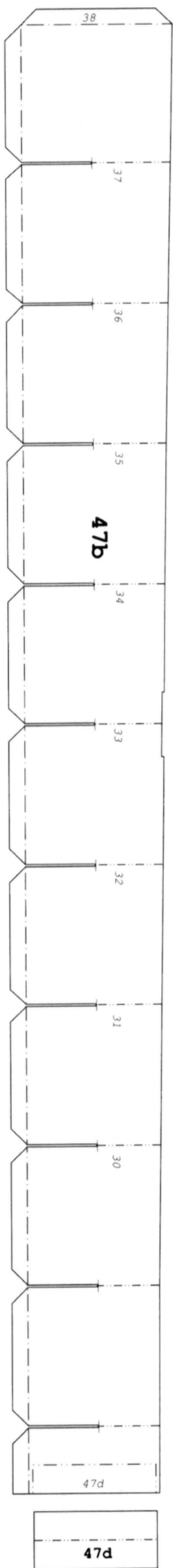

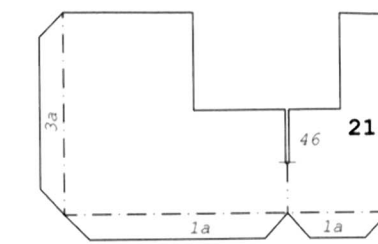
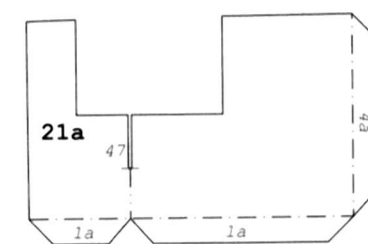
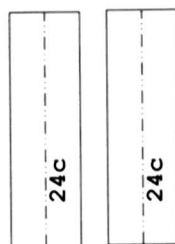
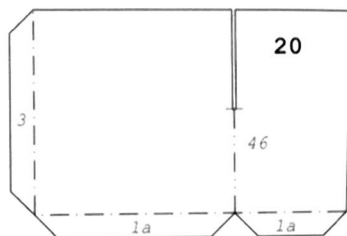
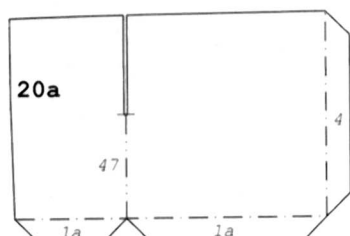
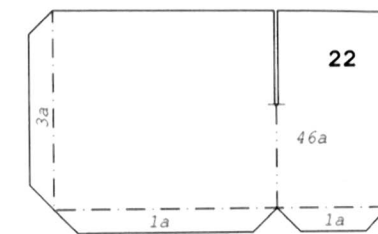
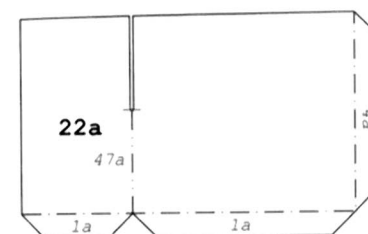
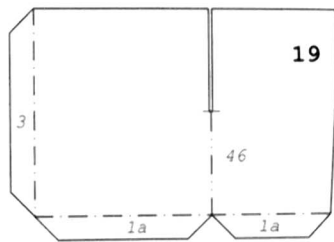
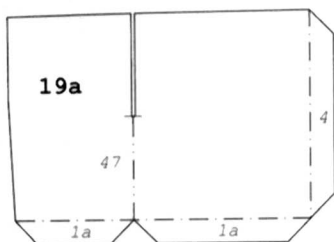
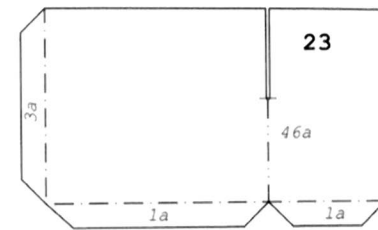
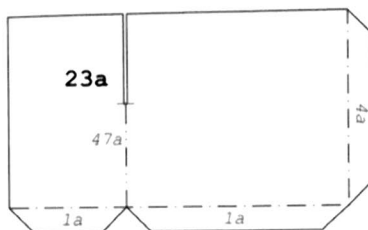
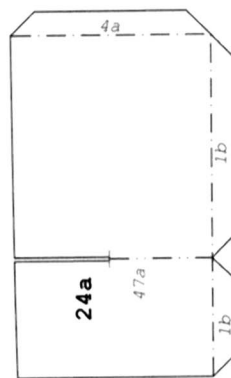
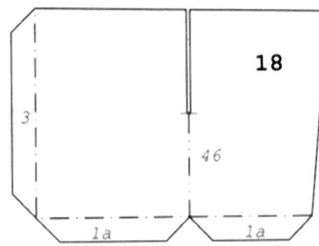
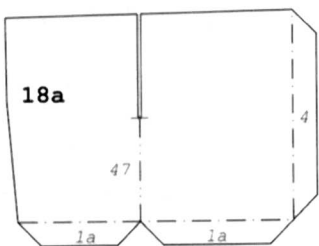
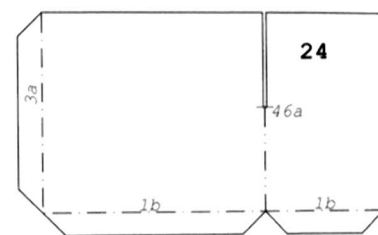
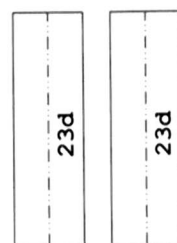
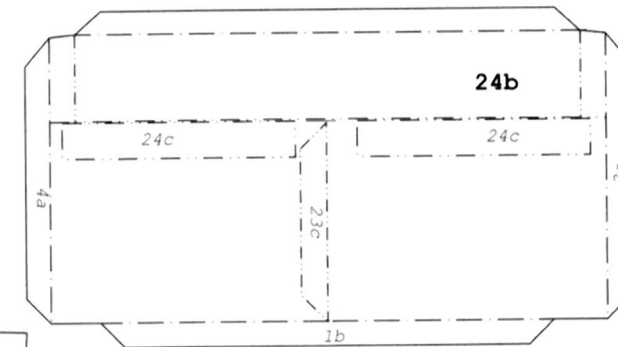
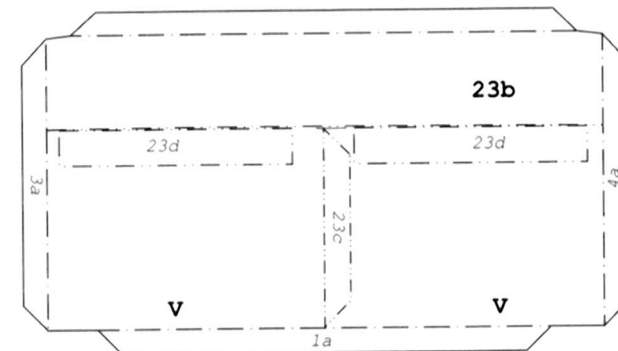
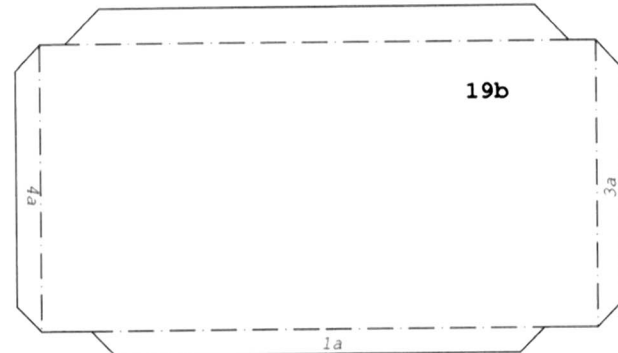
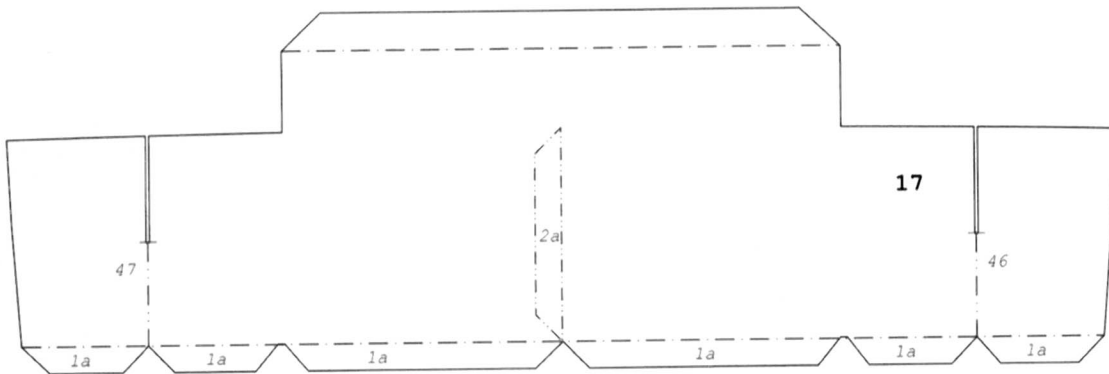
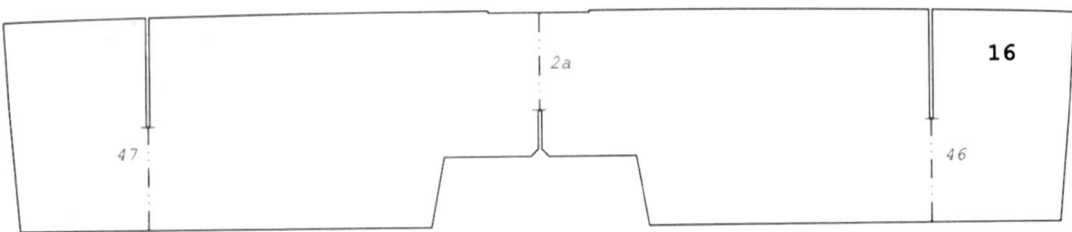
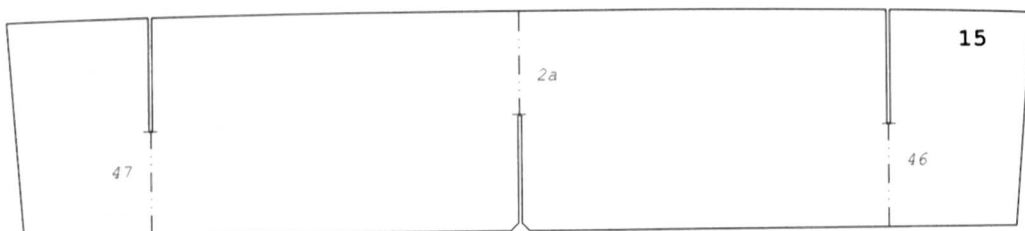
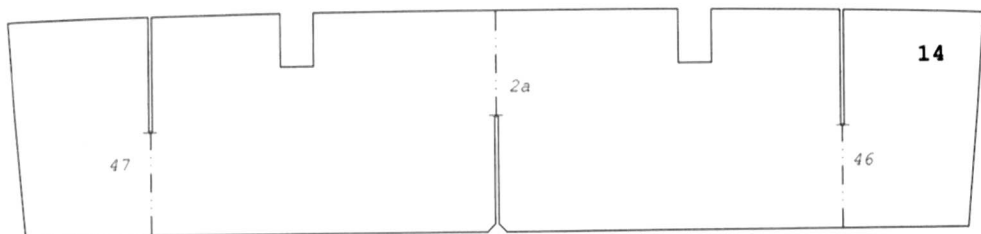
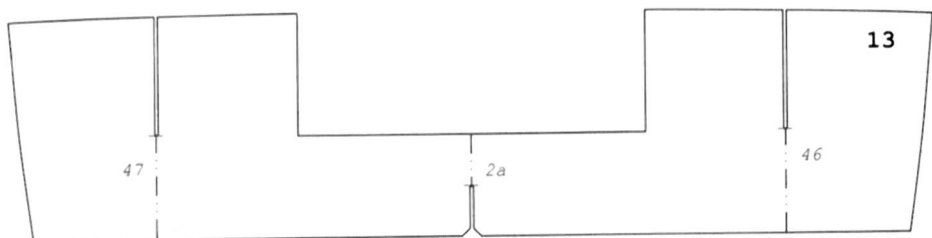
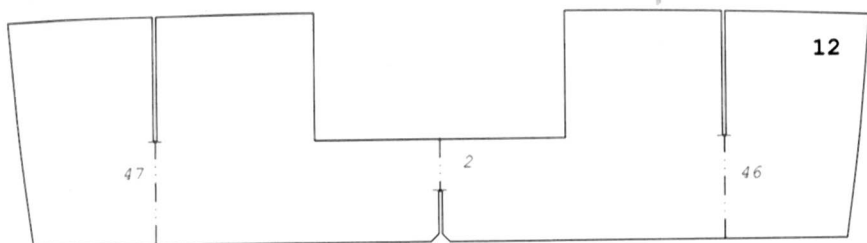

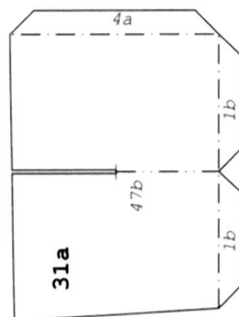
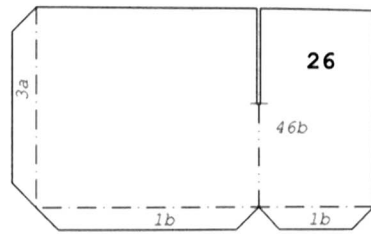
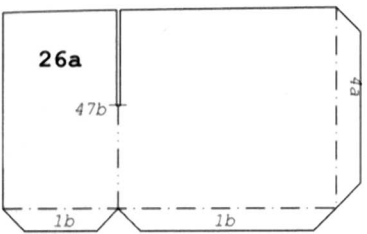
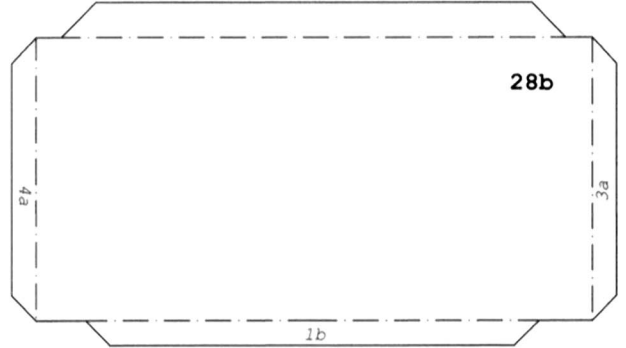
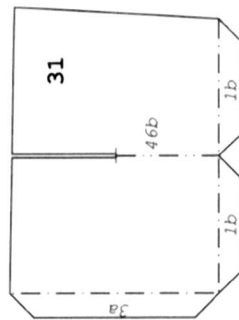
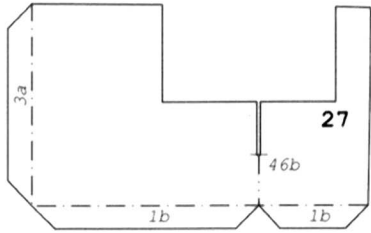
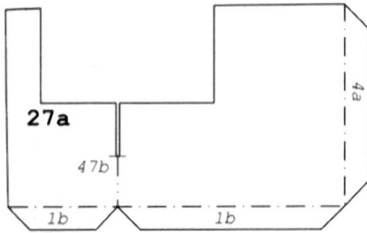
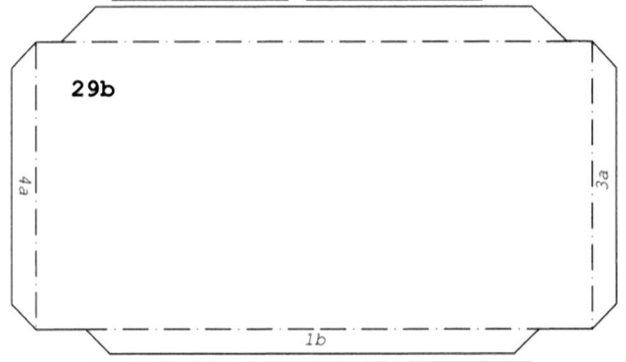
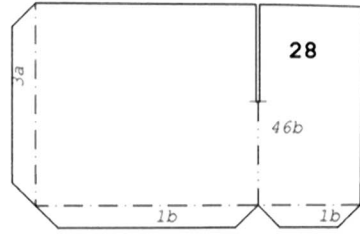
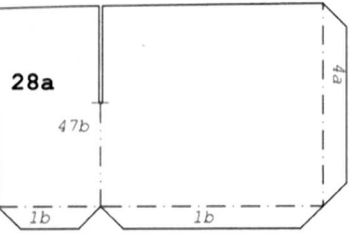
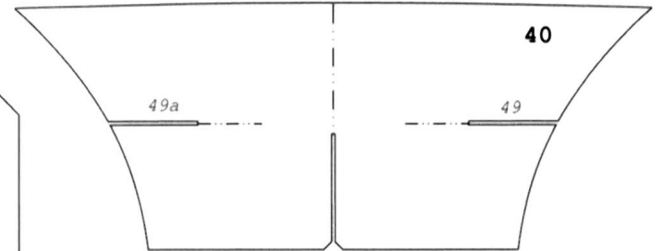
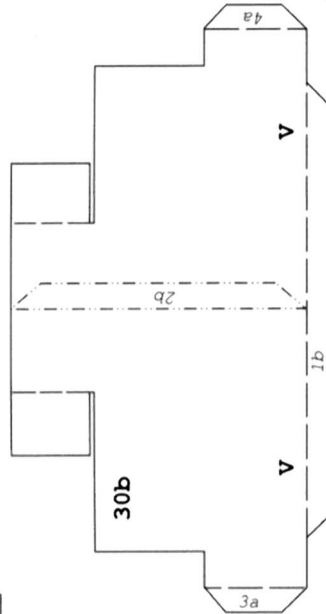
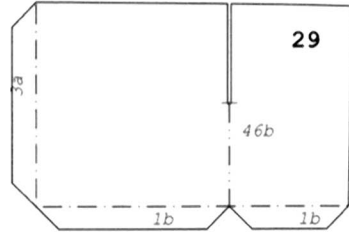
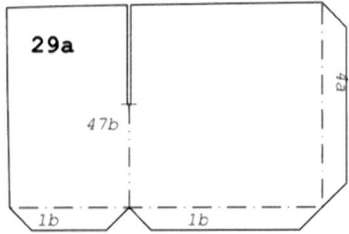
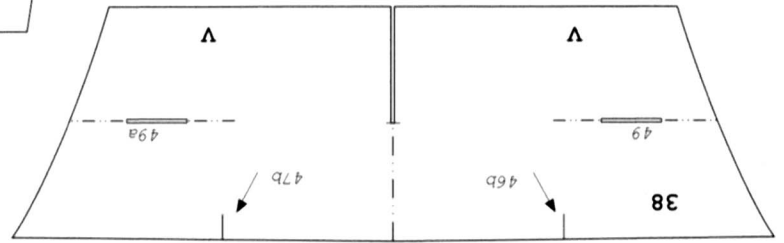
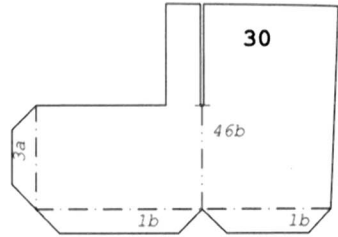
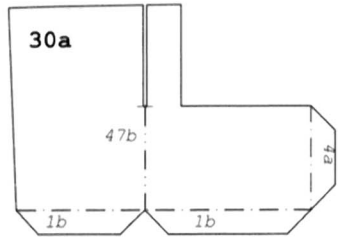
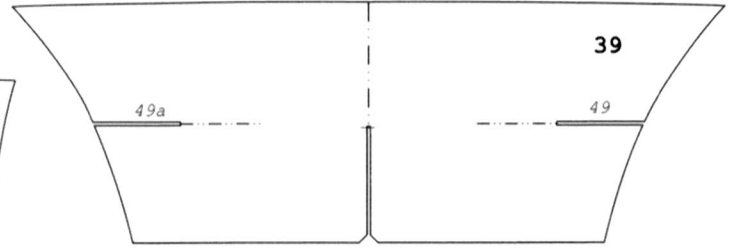
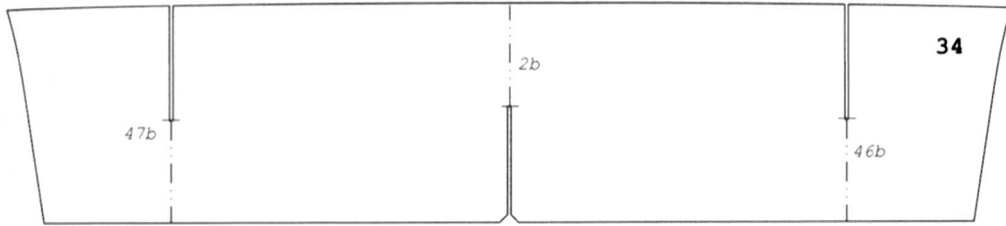
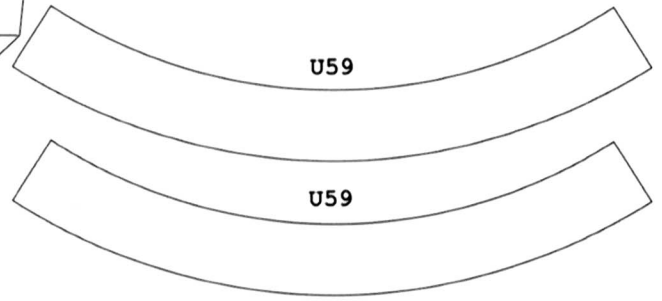
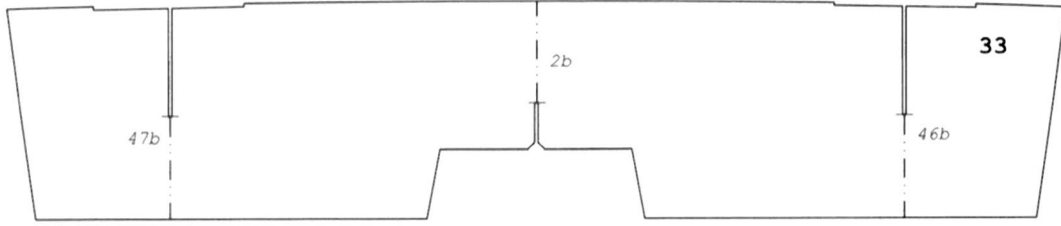
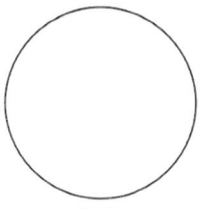
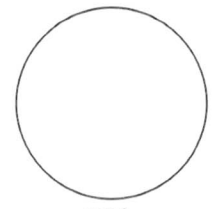
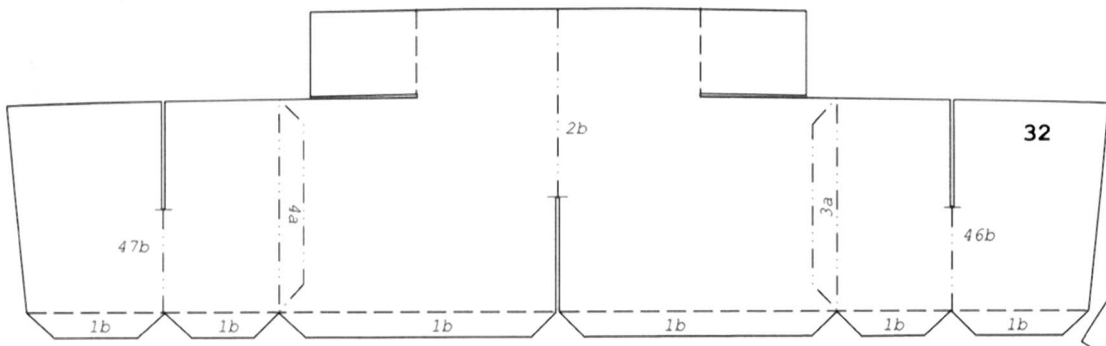

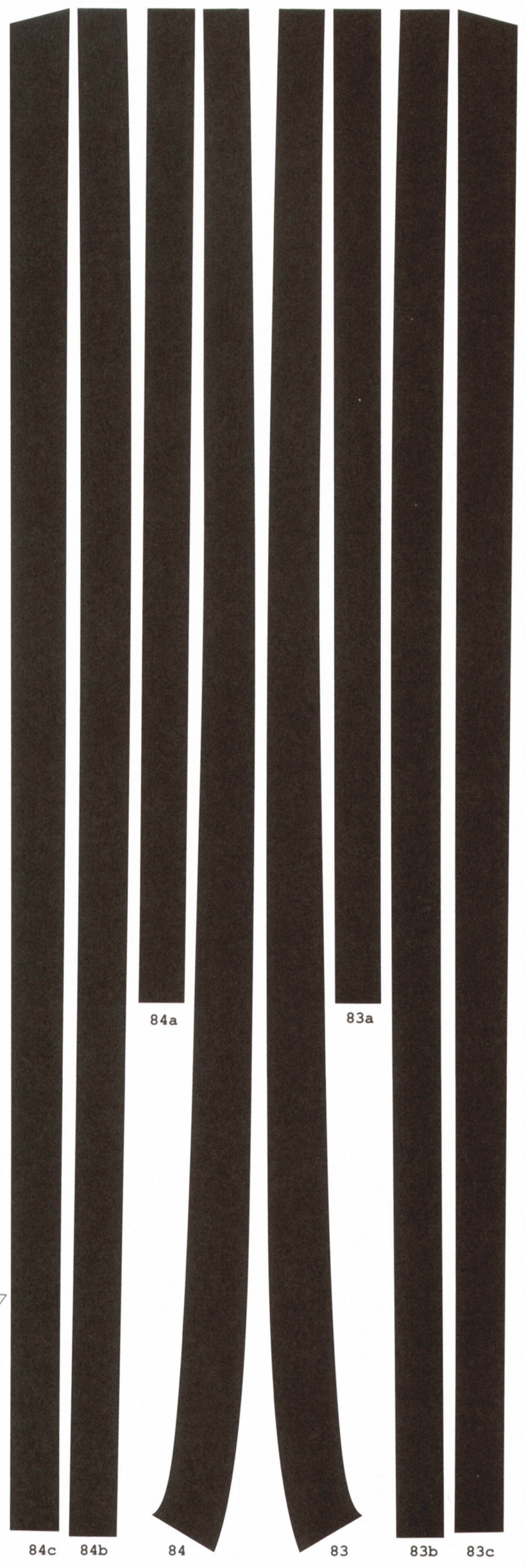
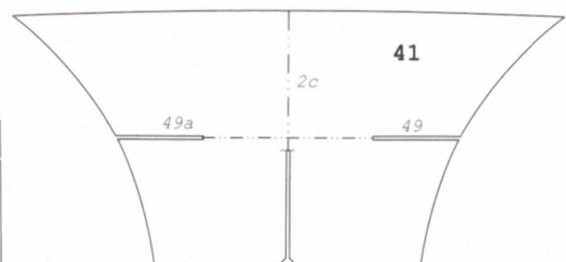
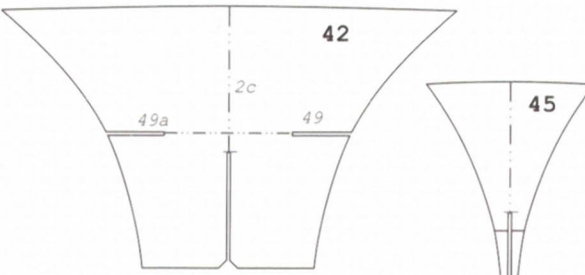
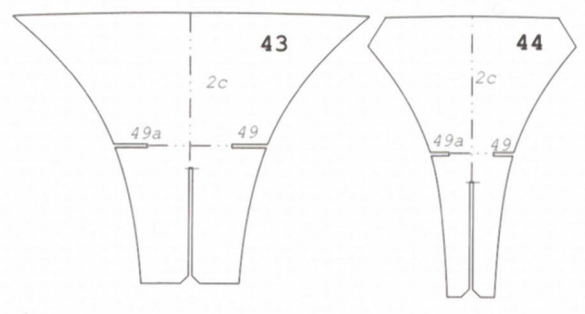
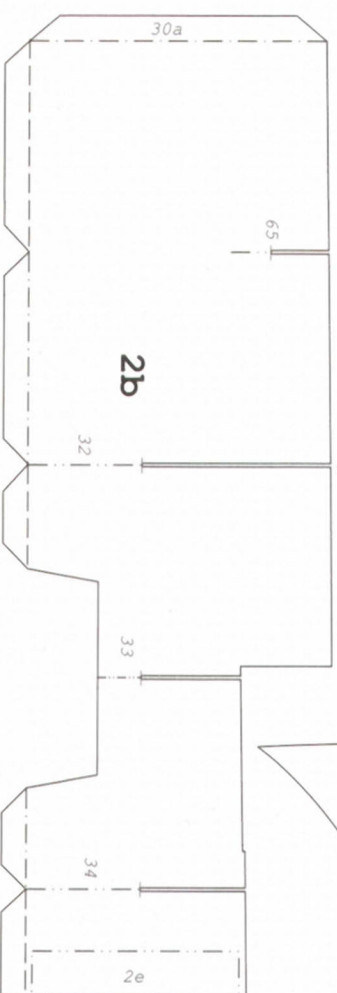
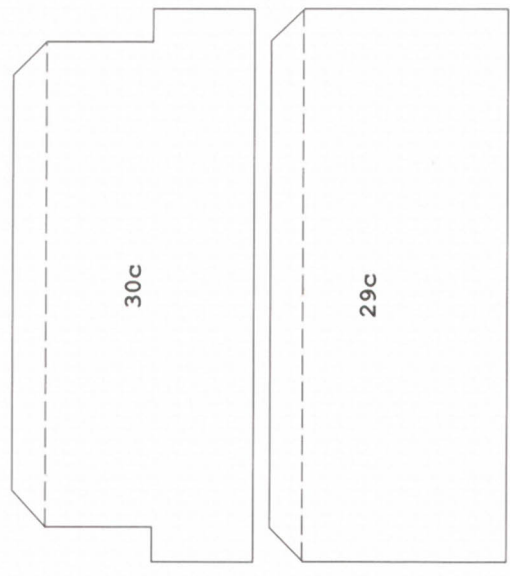
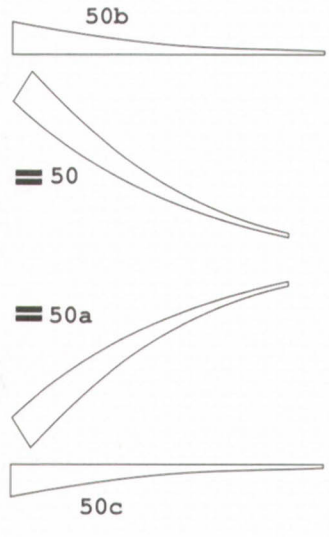
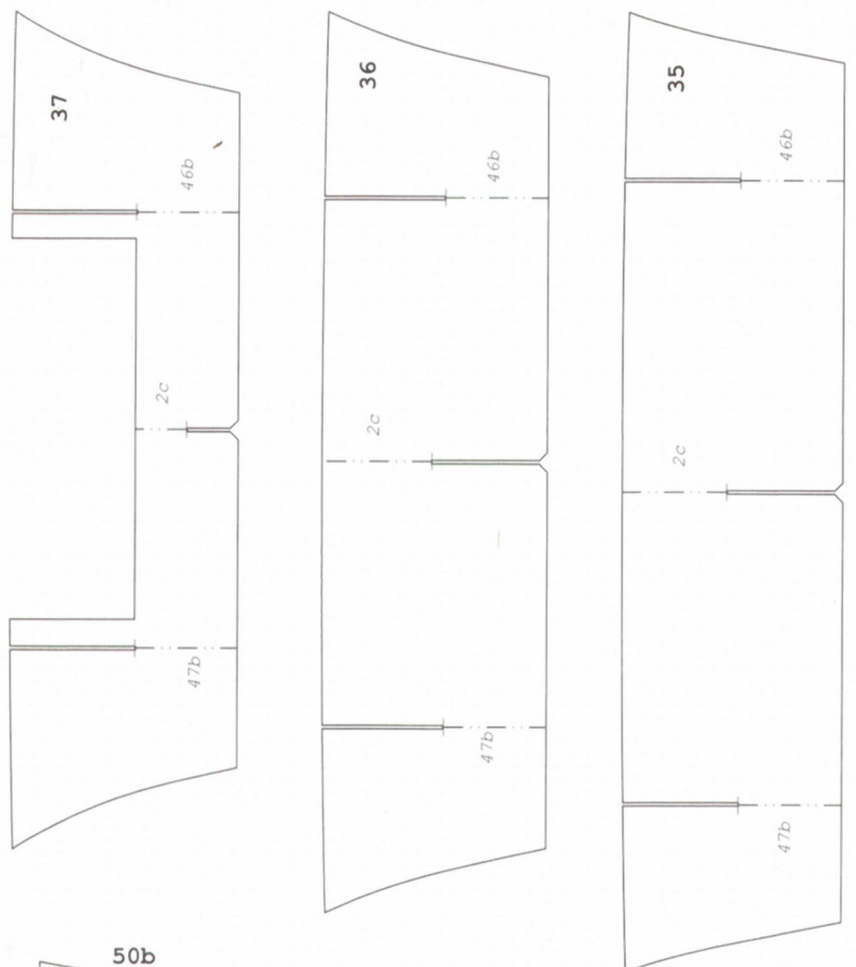

84c 84b 84 83 83b 83c

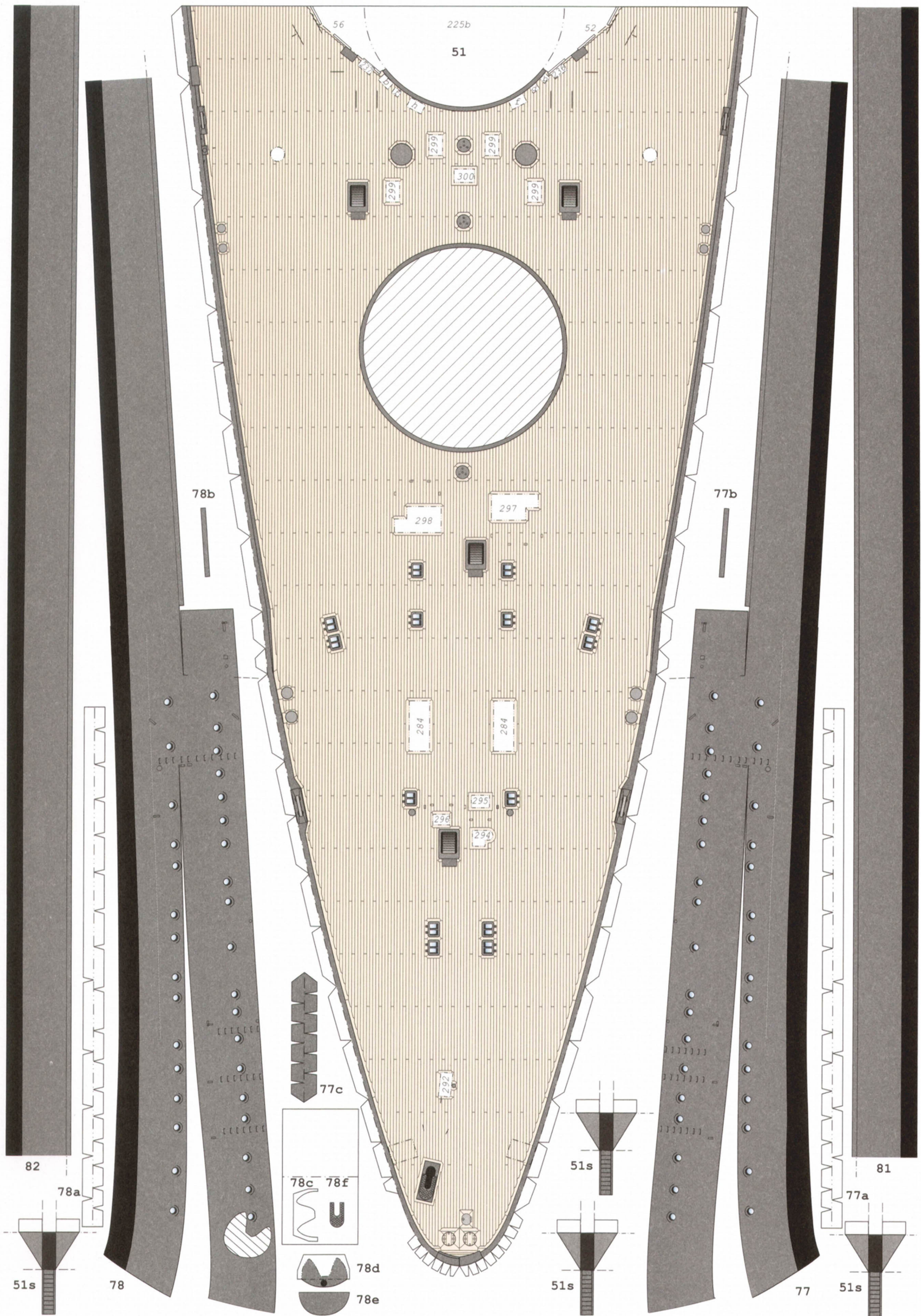

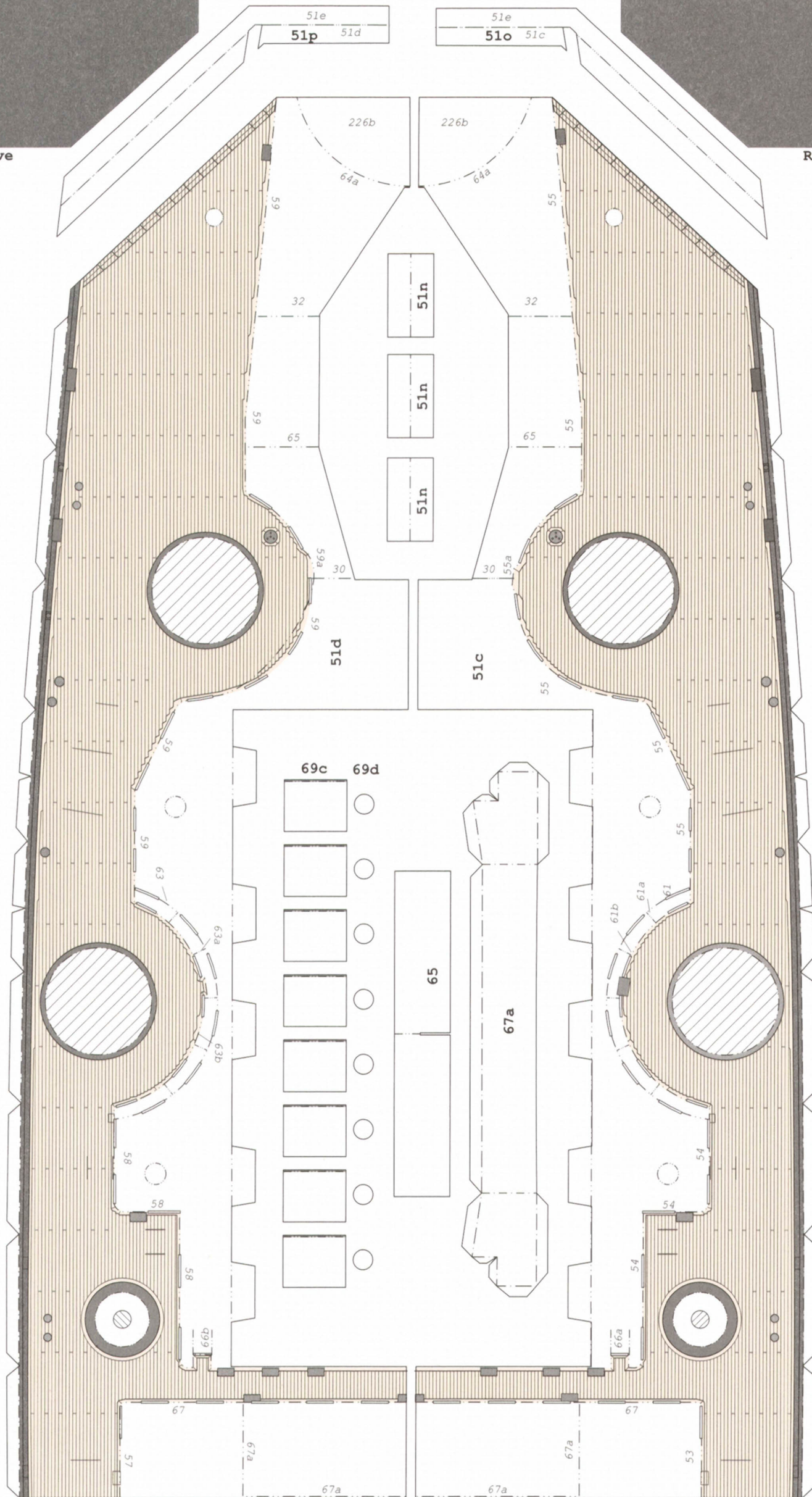

82a

81a

Reserve

Reserve

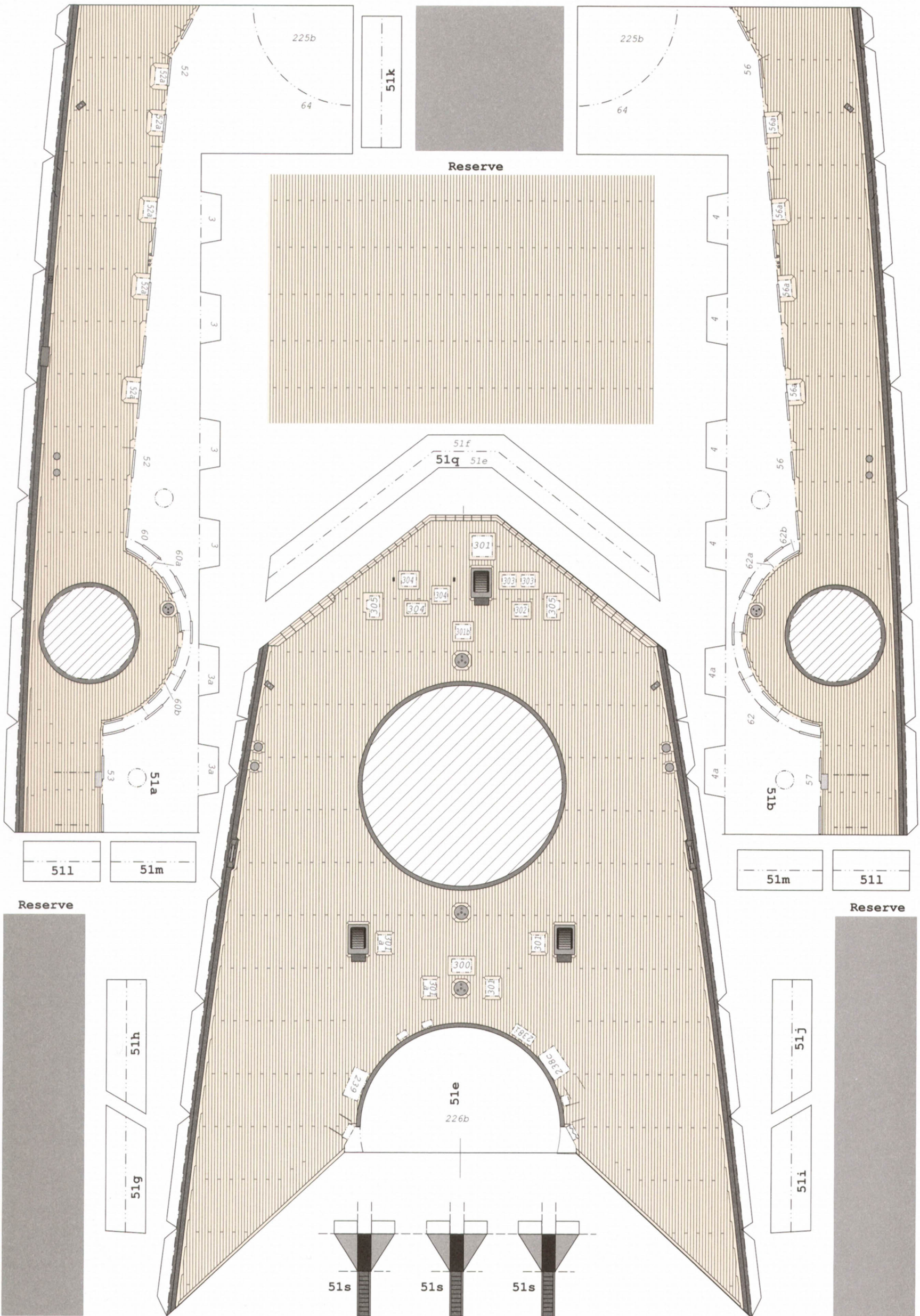

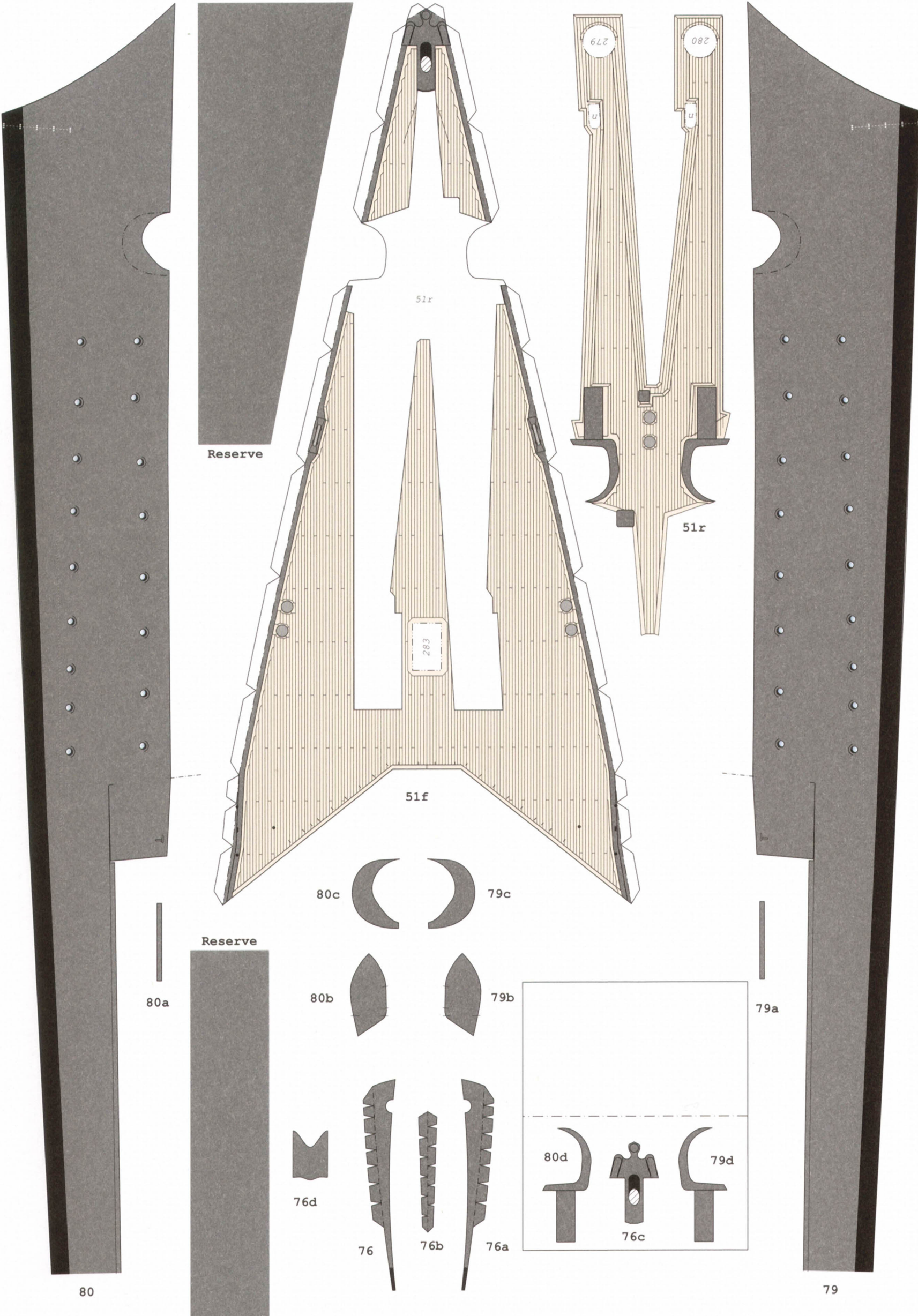

Reserve

51r

51r

51f

283

80c

79c

Reserve

80a

80b

79b

79a

76d

76

76b

76a

80d

76c

79d

80

79

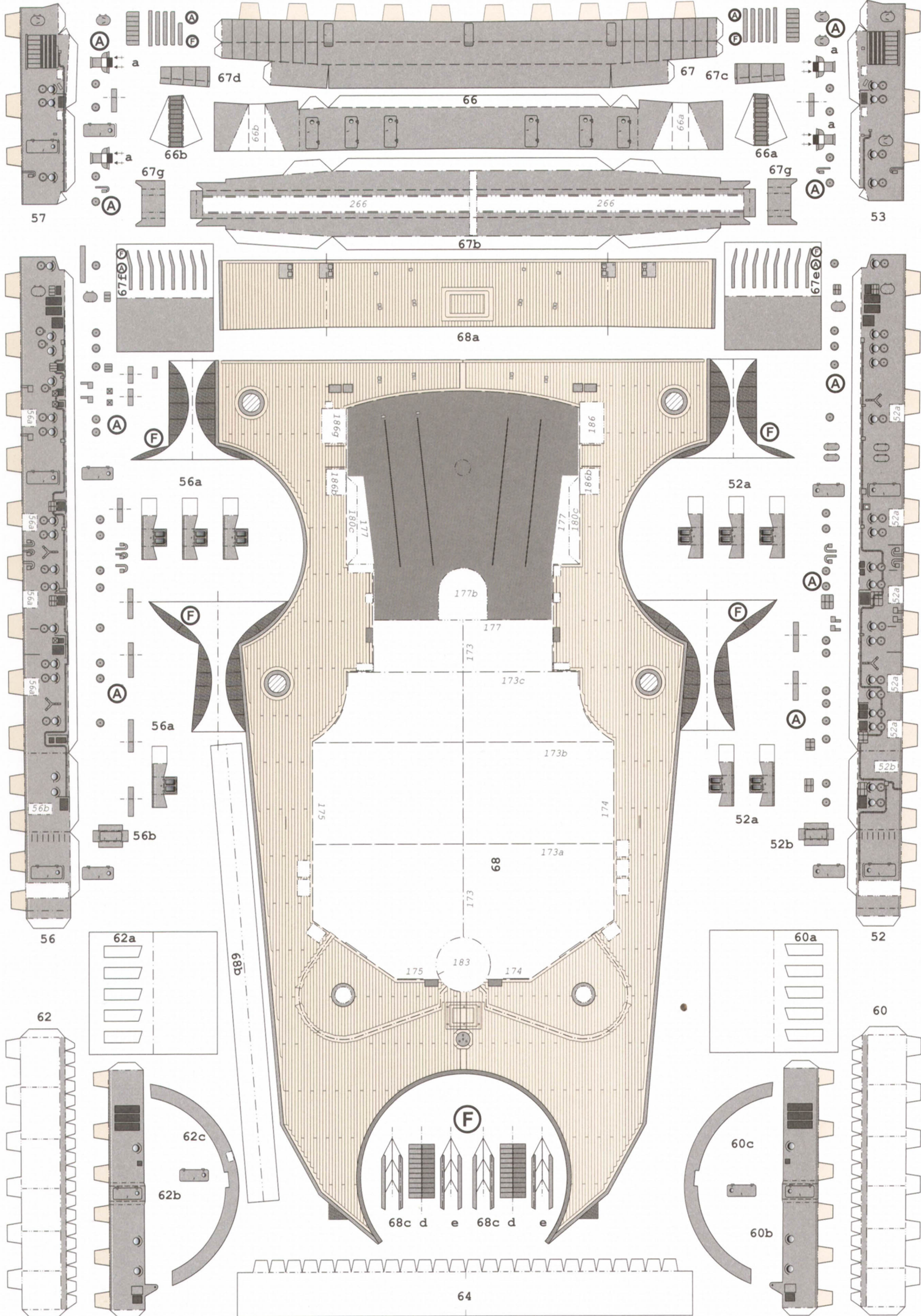

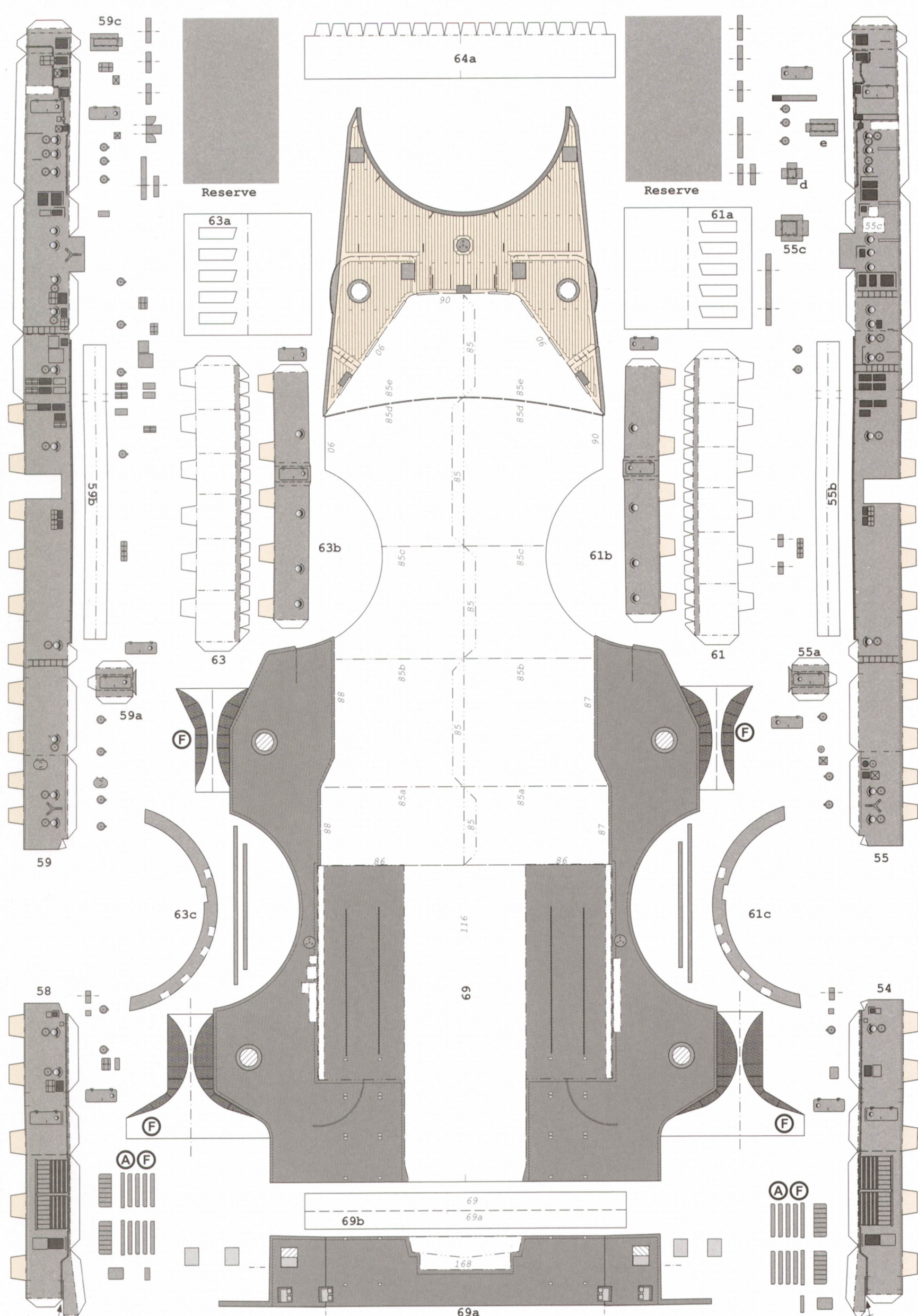

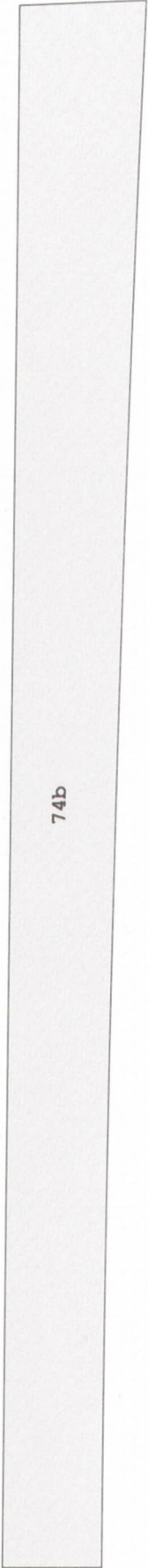

74b

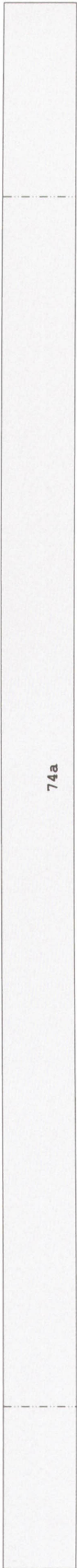

74a

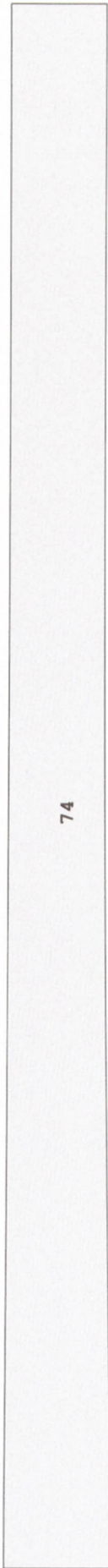

71

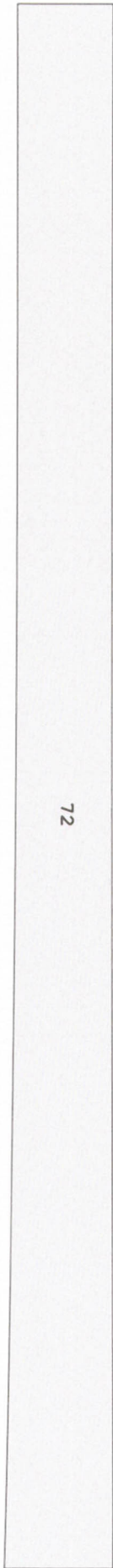

72

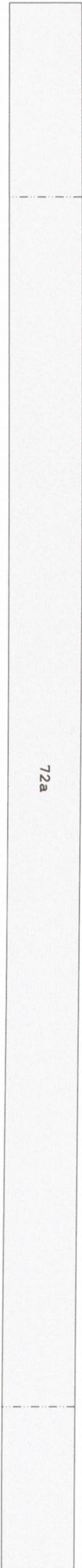

72a

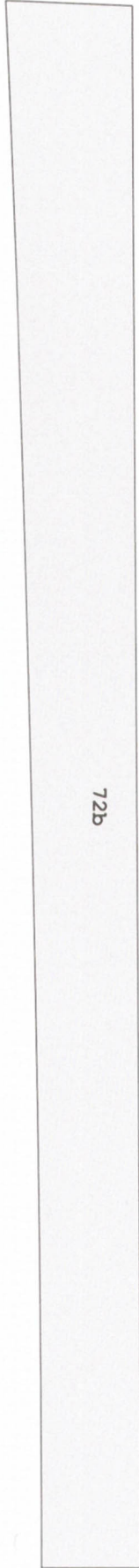

72b

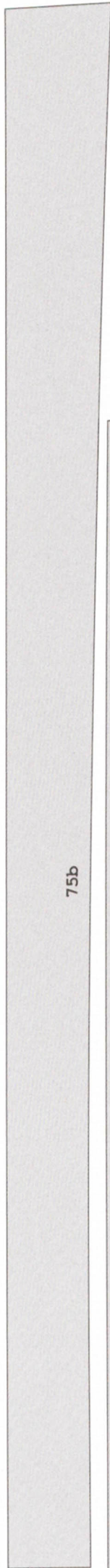

75L



75a



5L

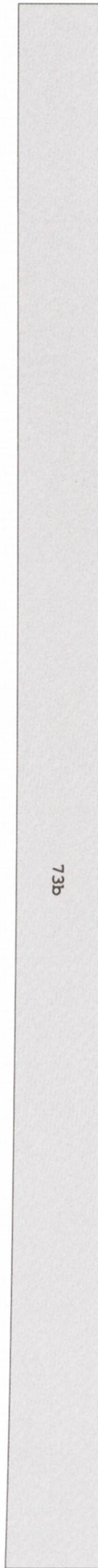

73b



73a

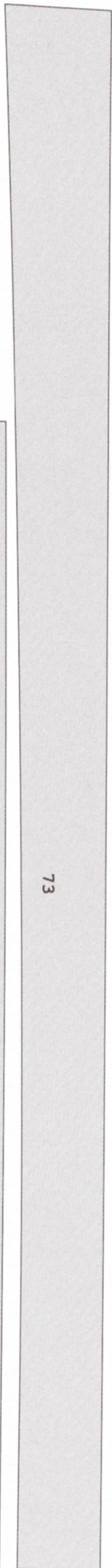

73

Reserve

Reserve

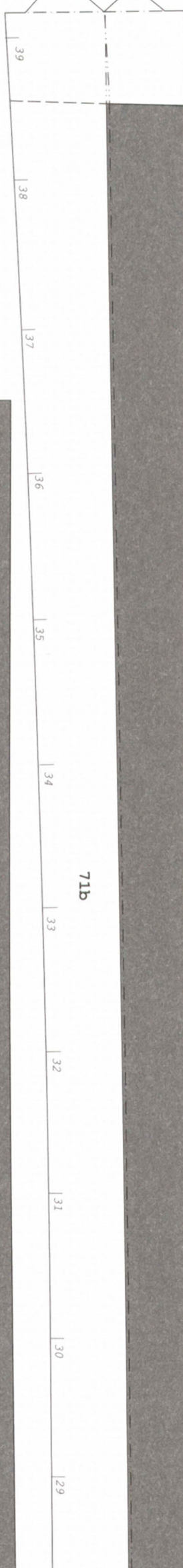
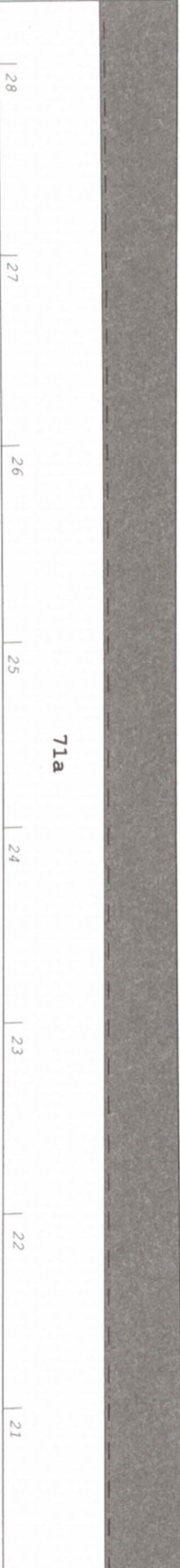
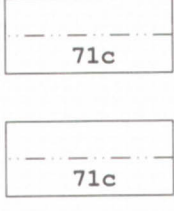
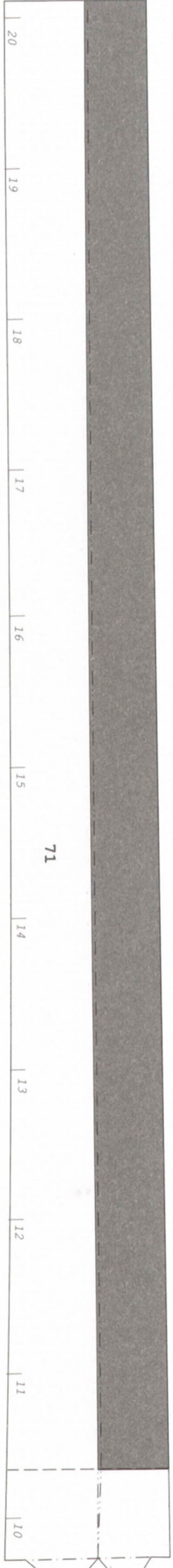

Reserve

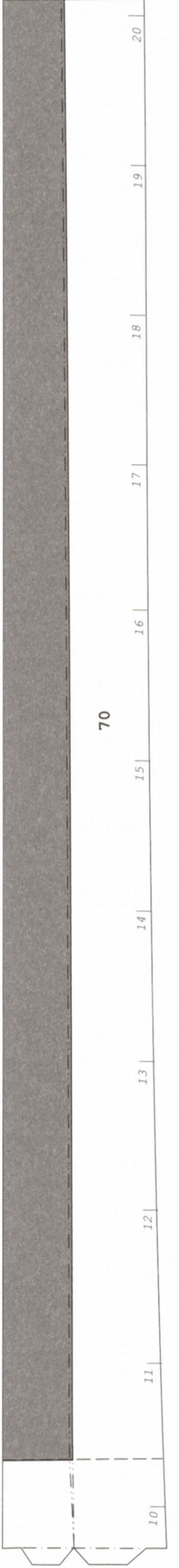
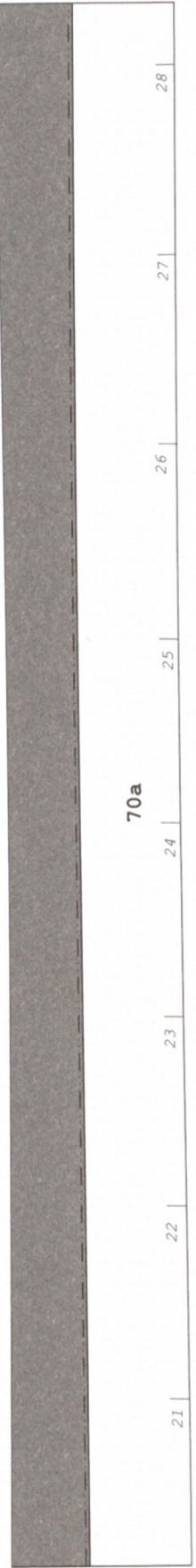
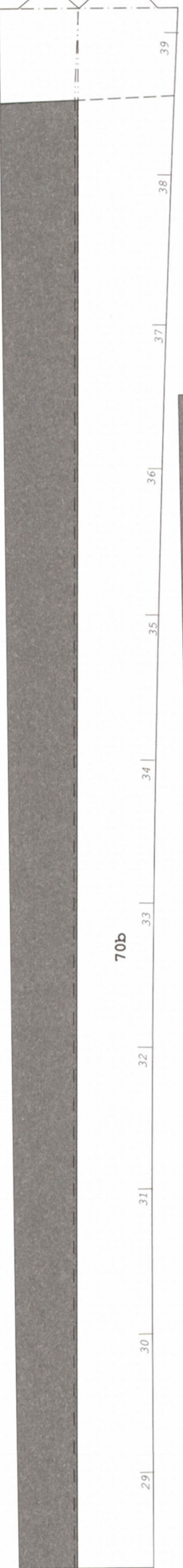
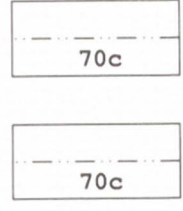

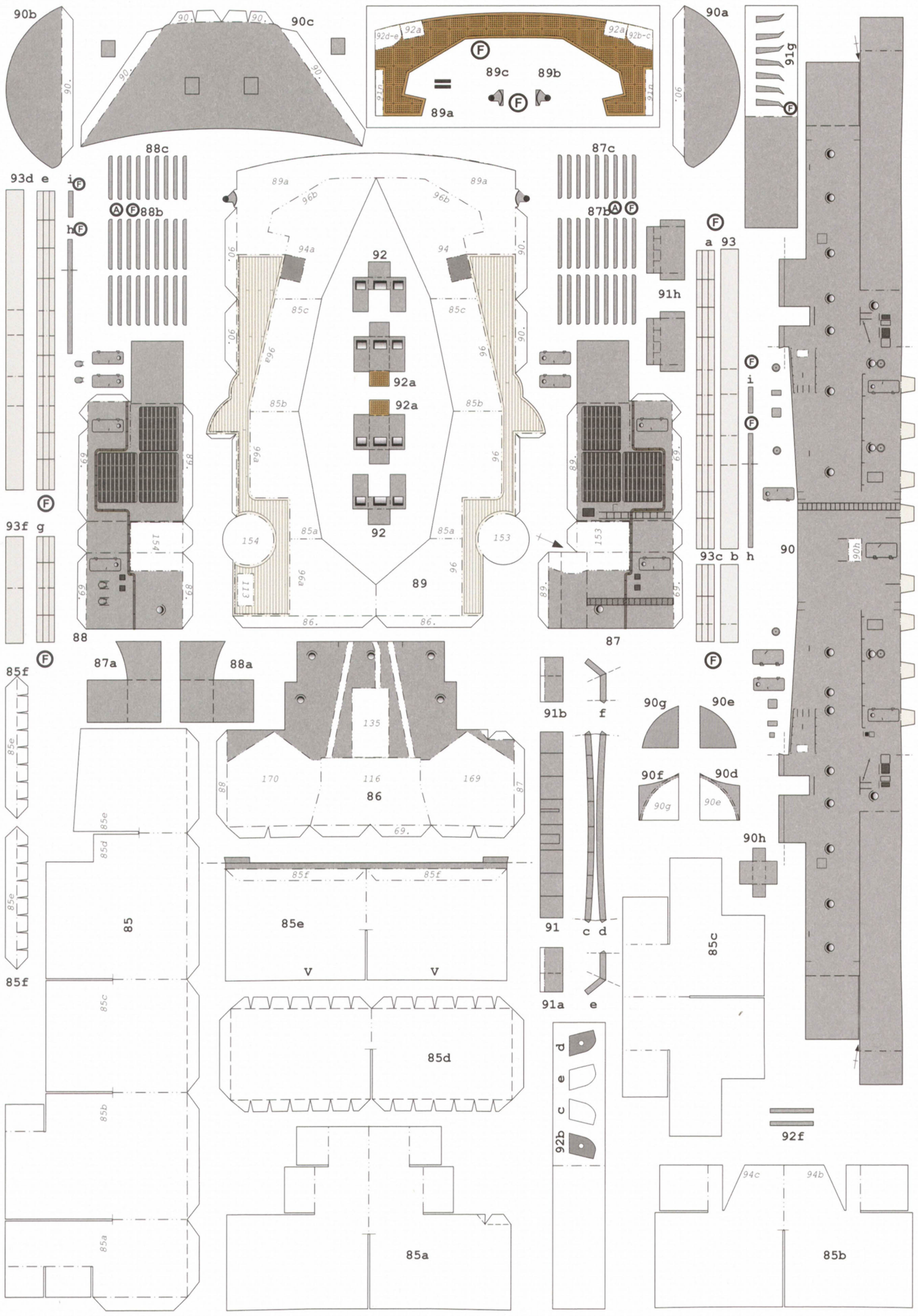

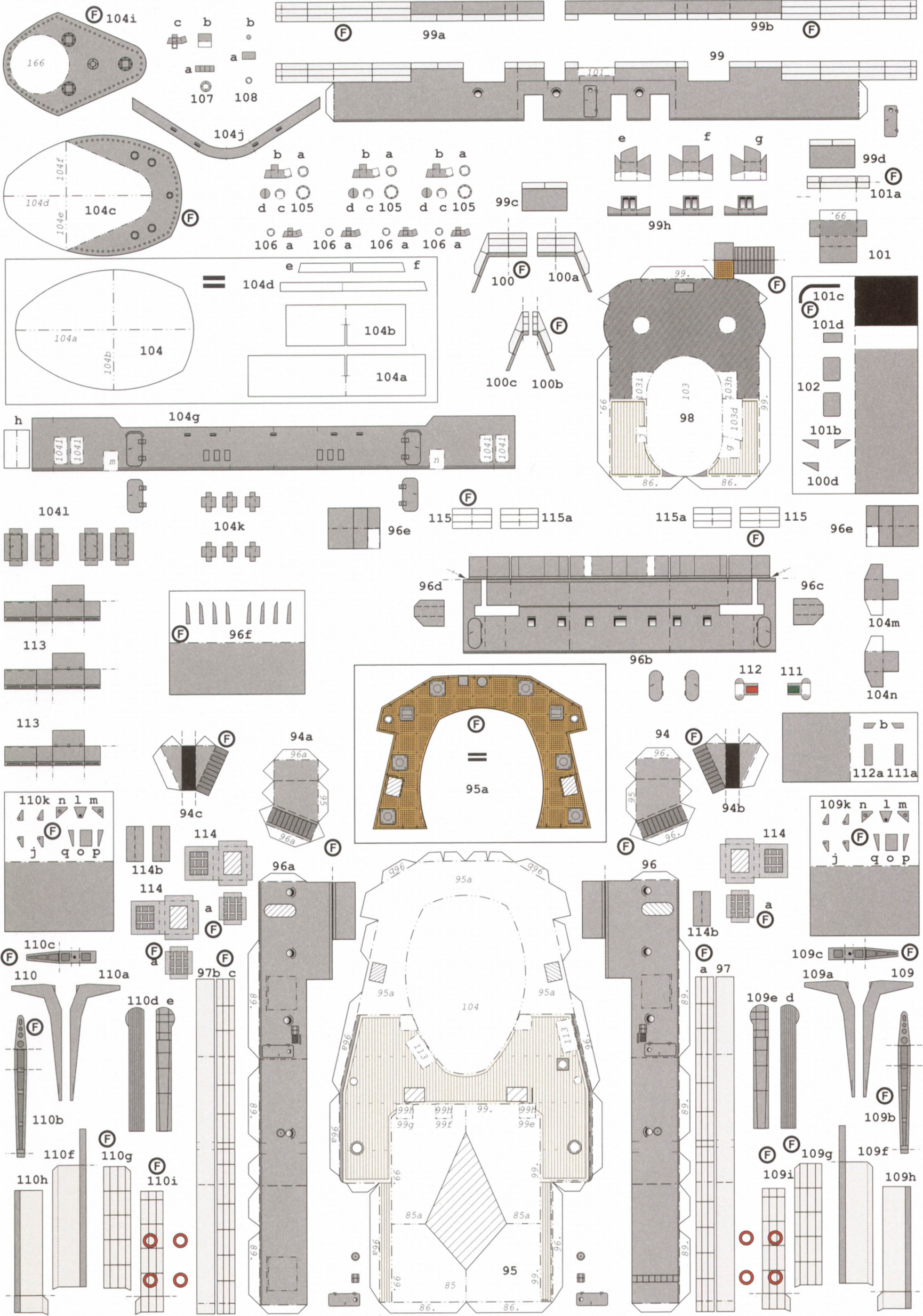

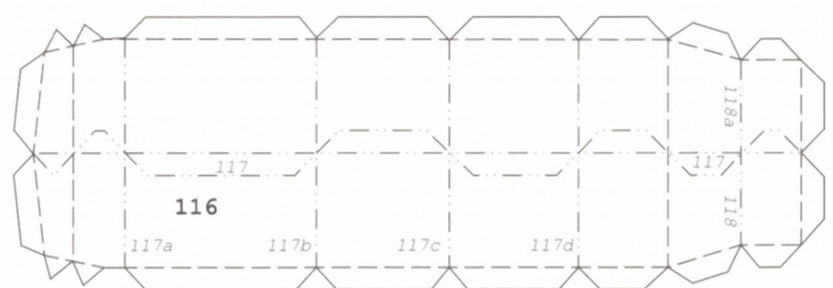
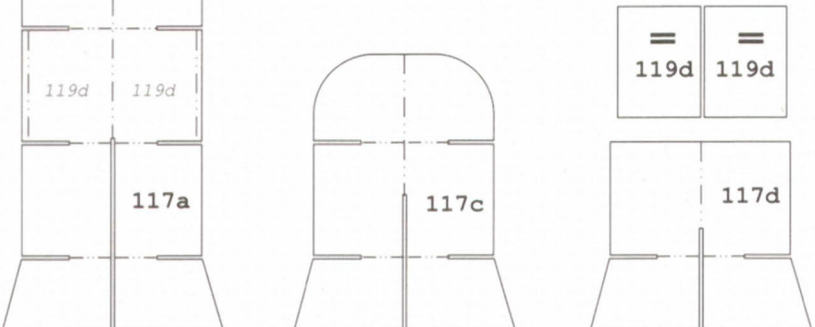
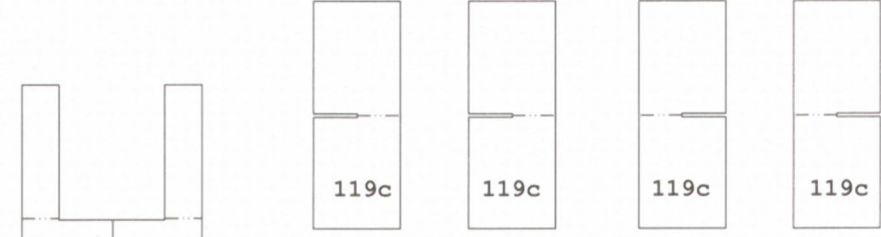
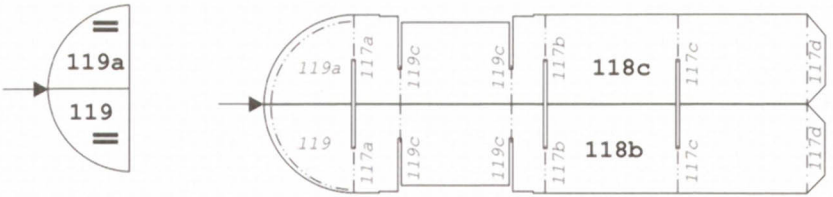
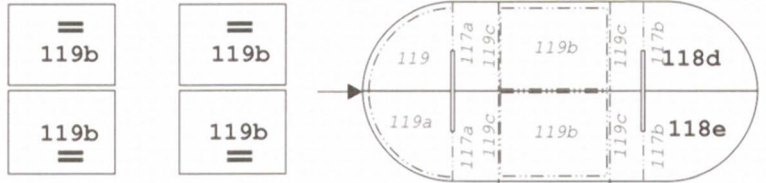
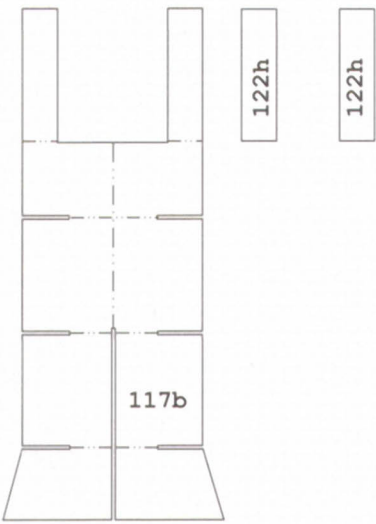
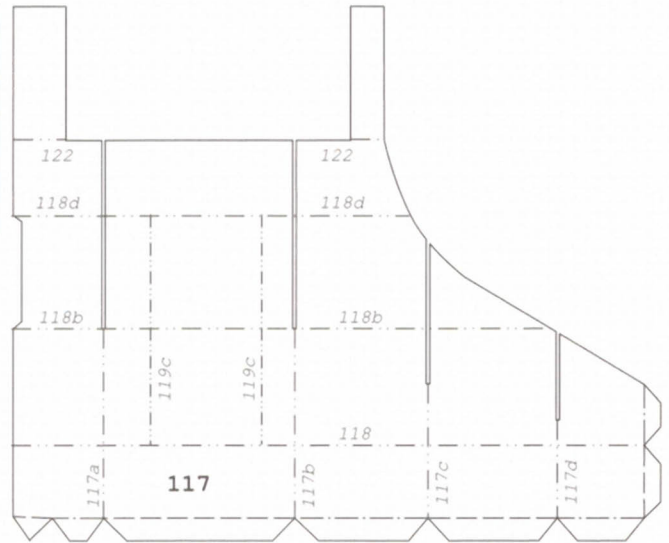
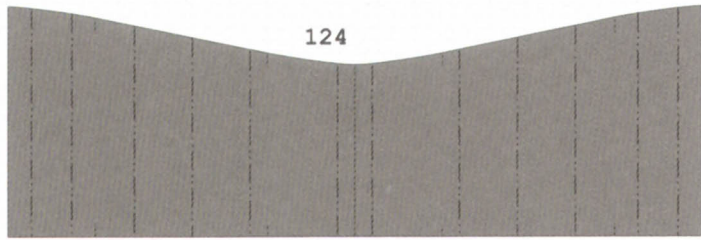
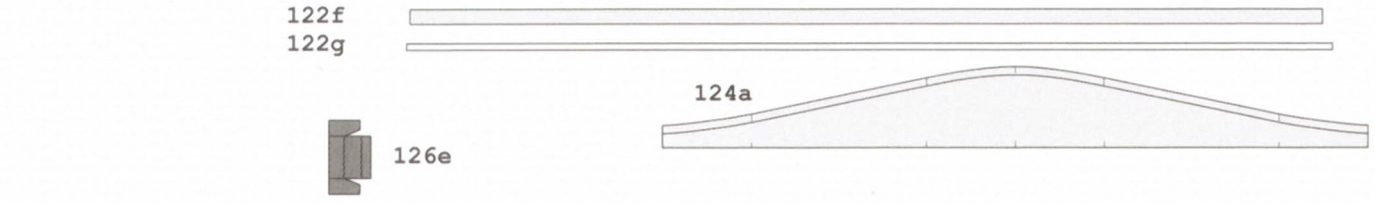
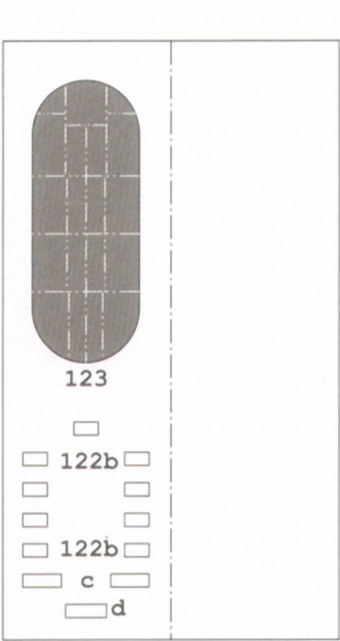
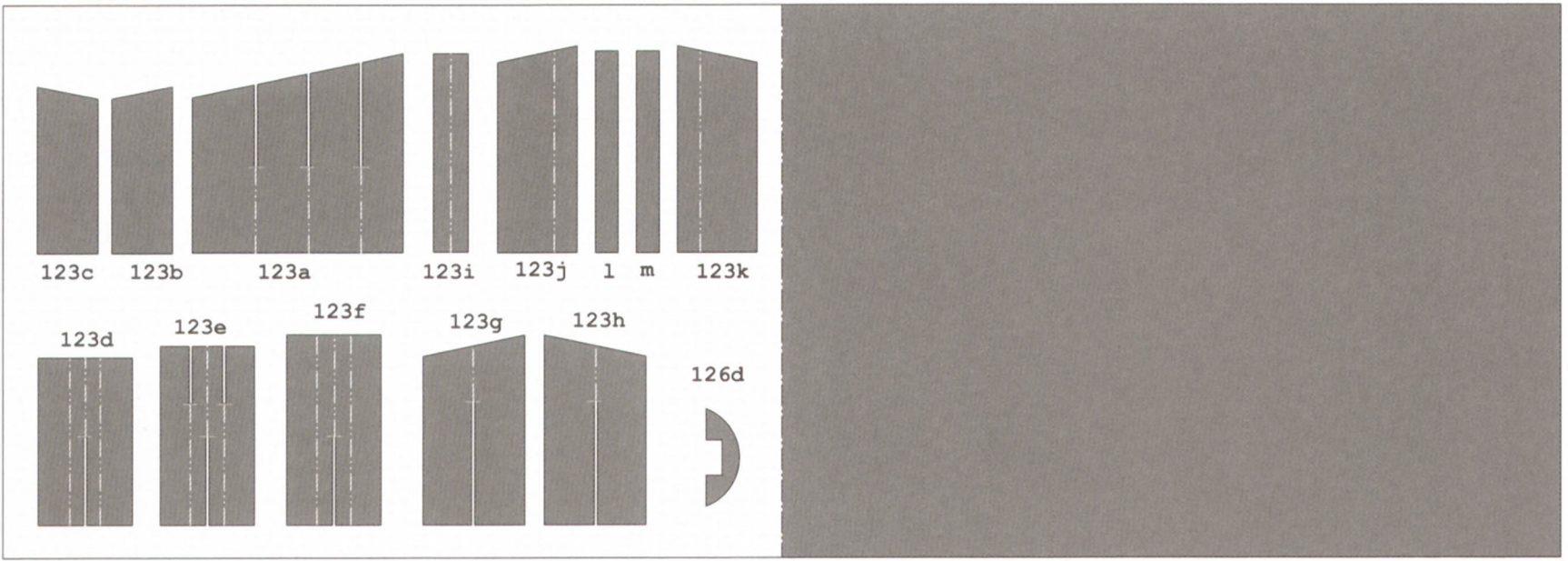

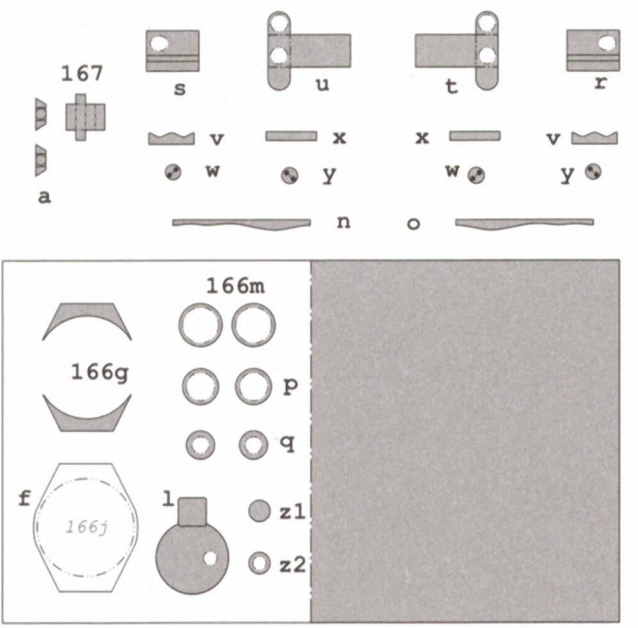
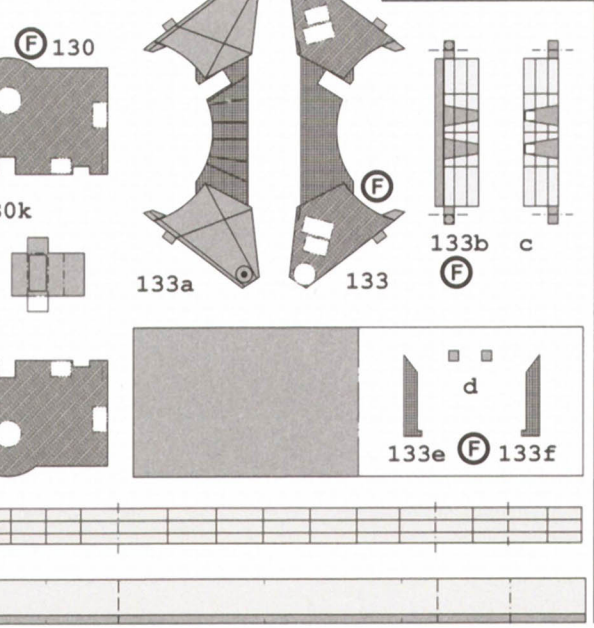
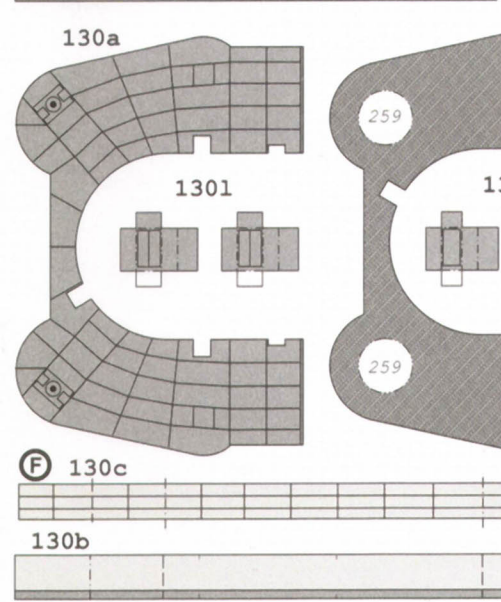
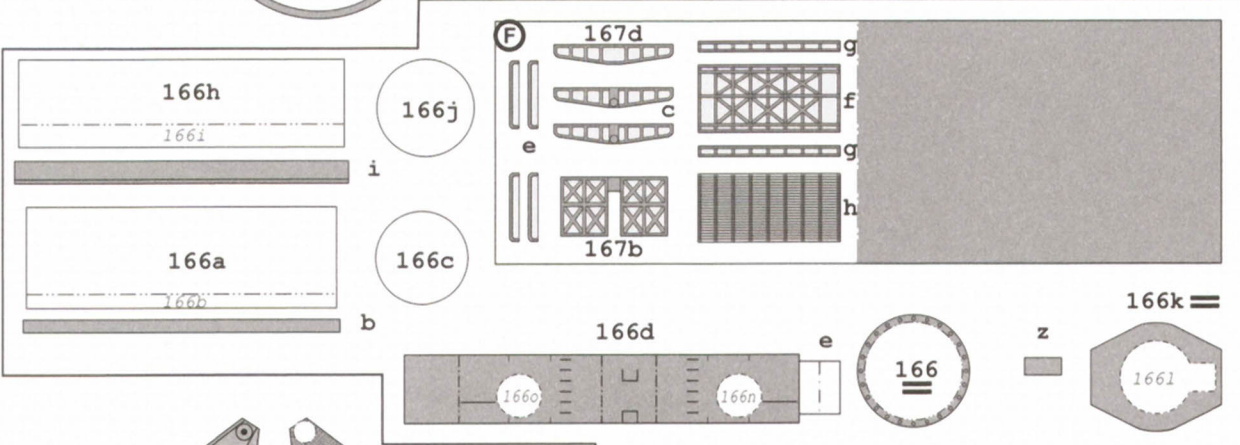
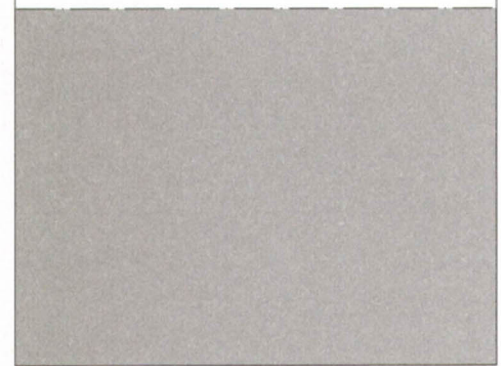
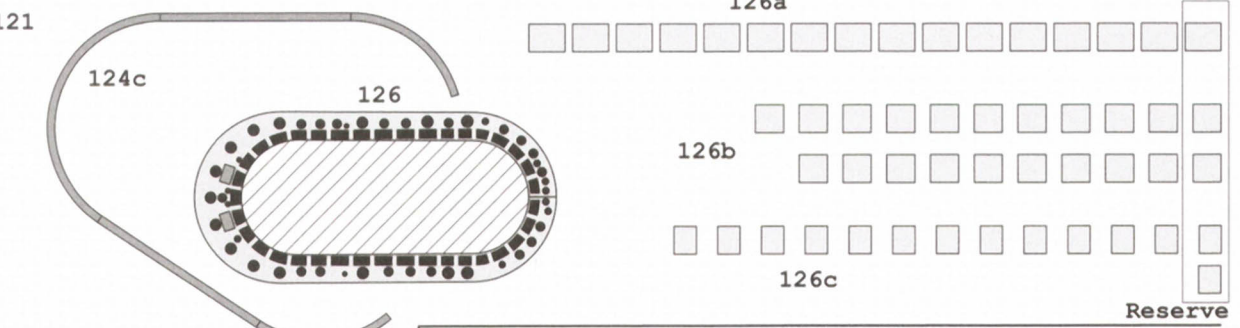
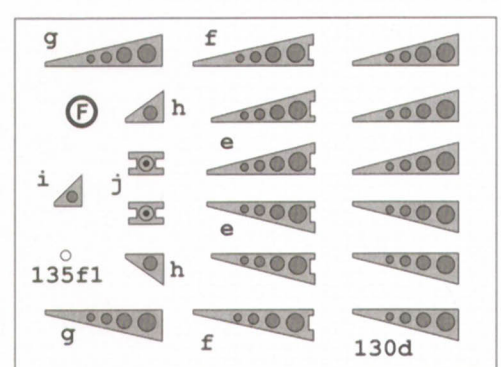
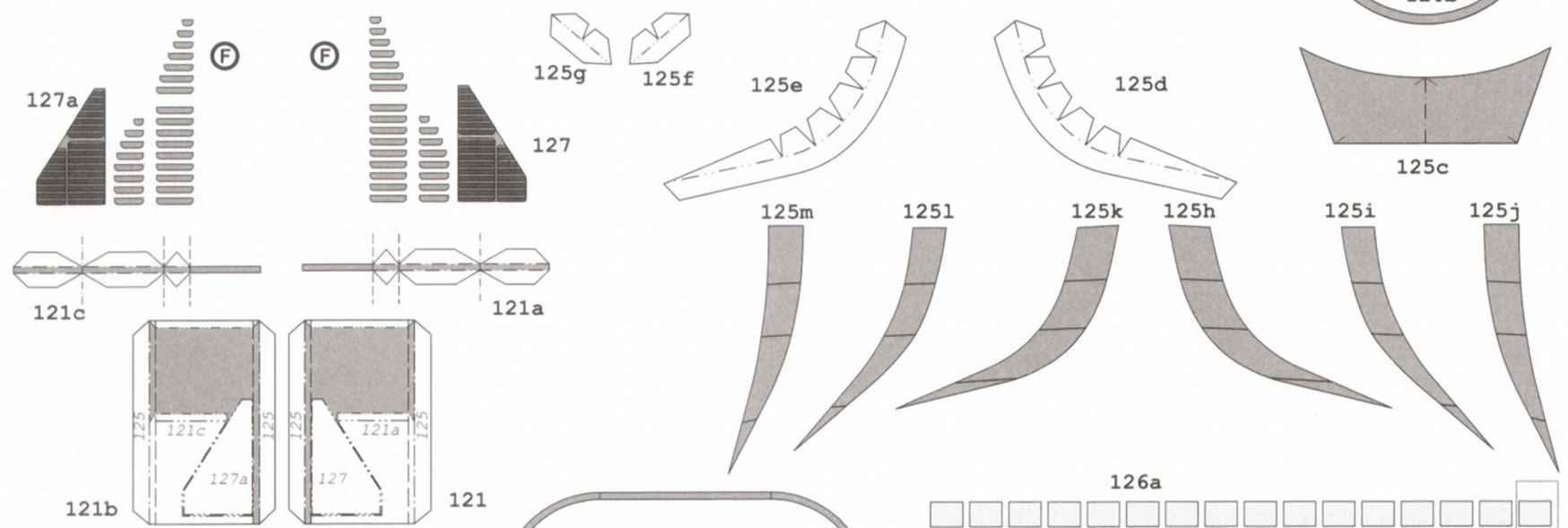
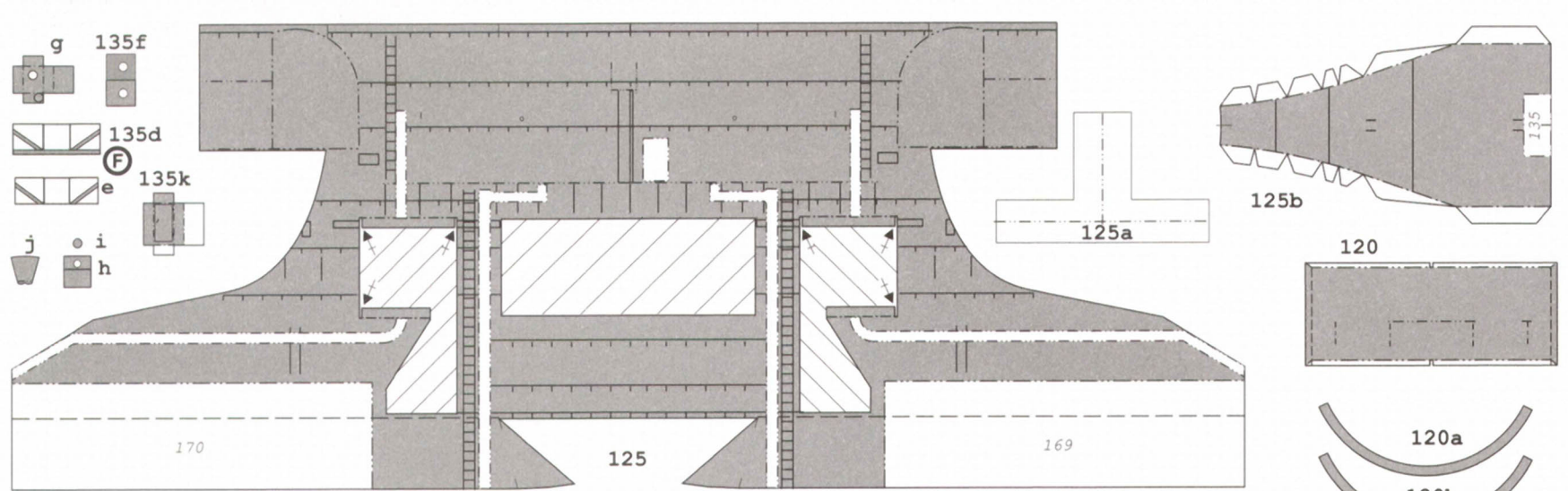

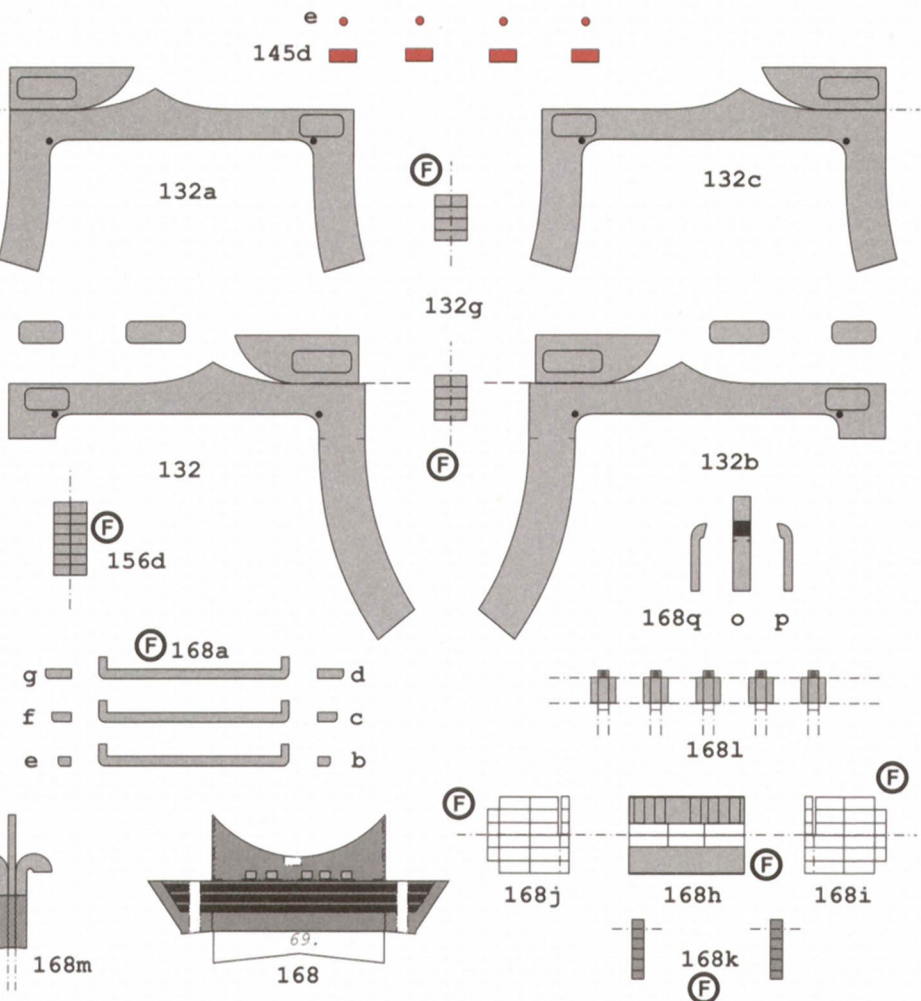
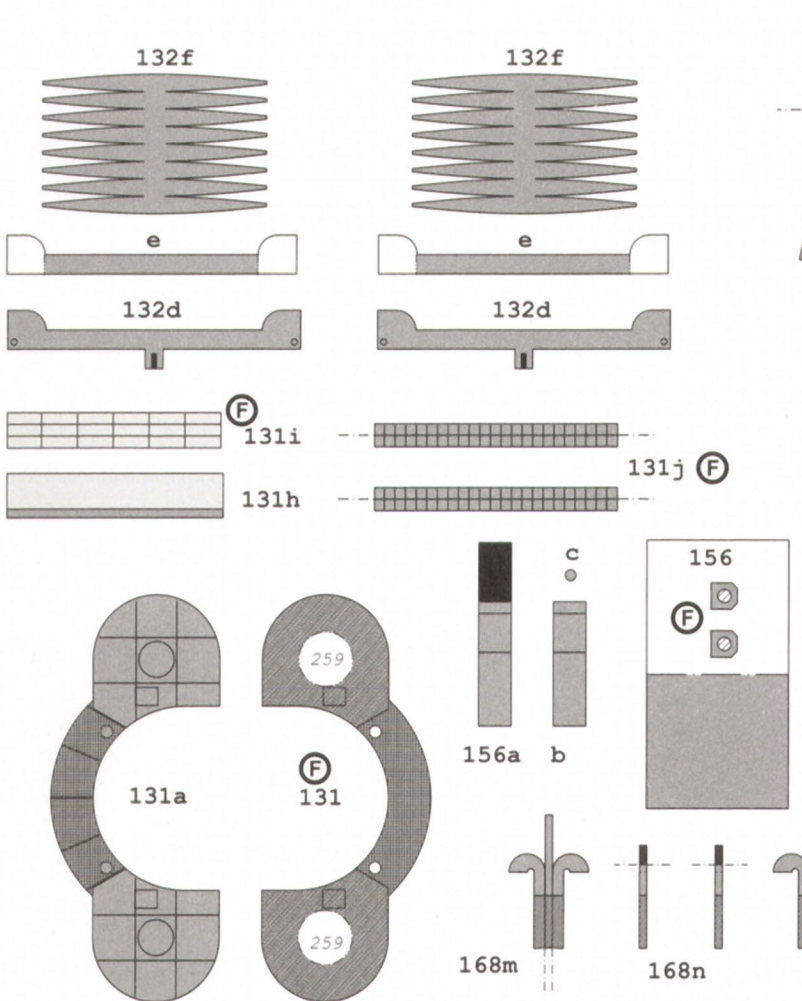
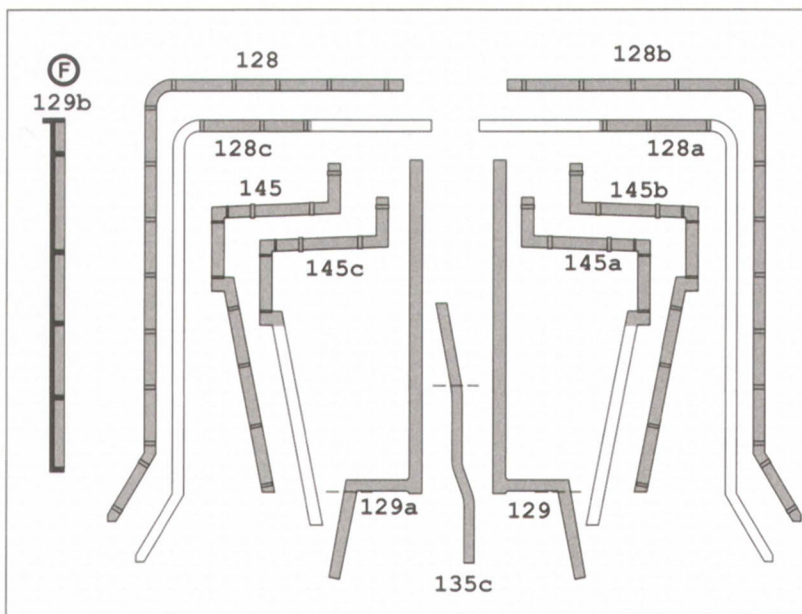
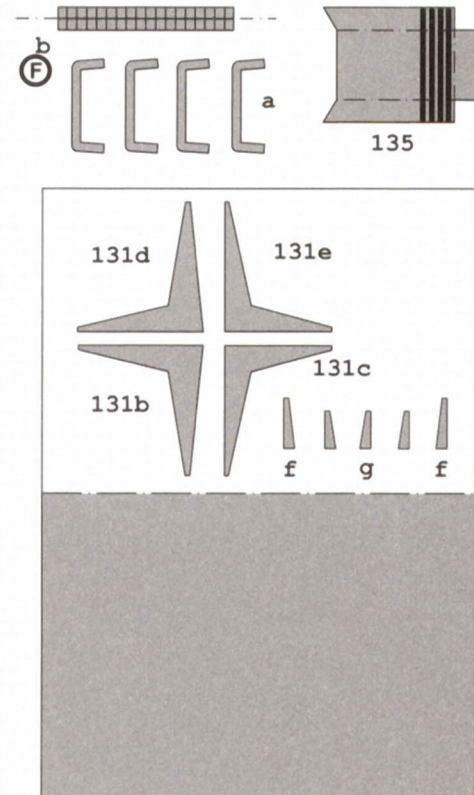
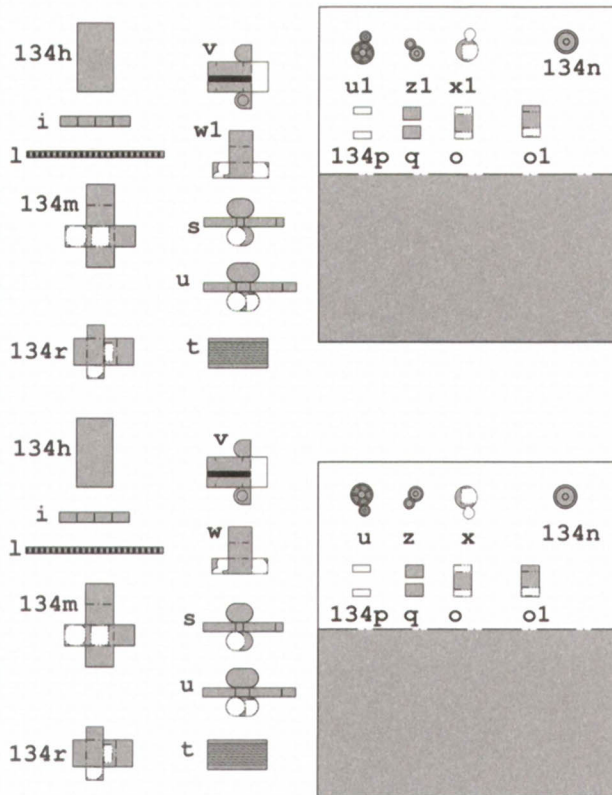
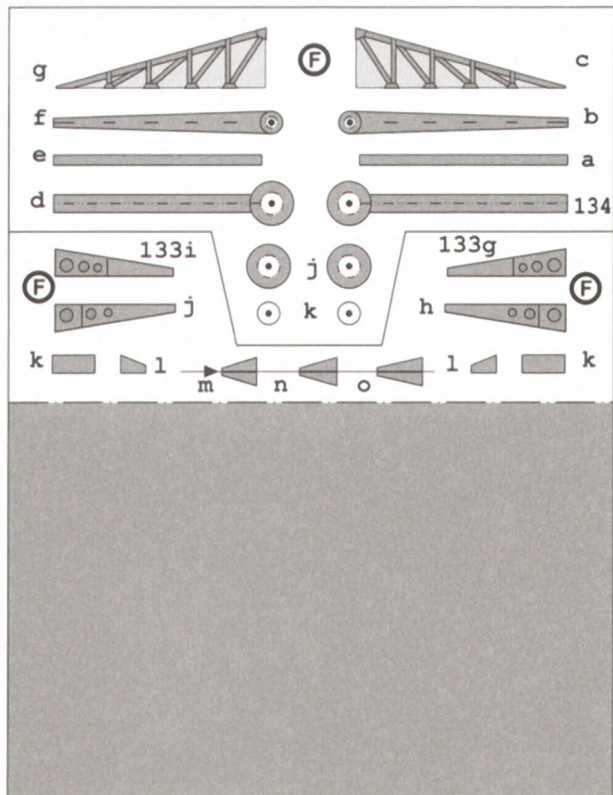

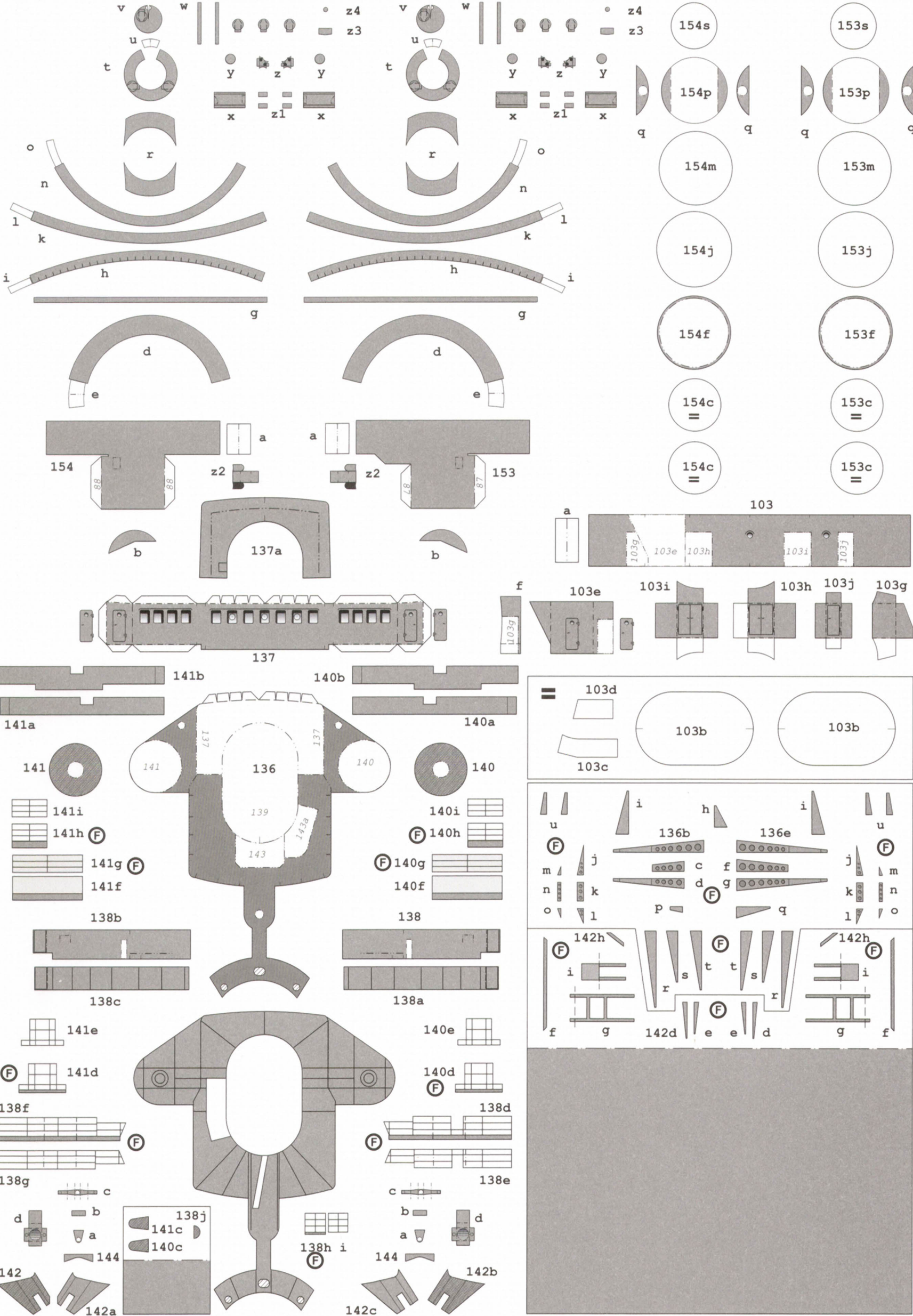

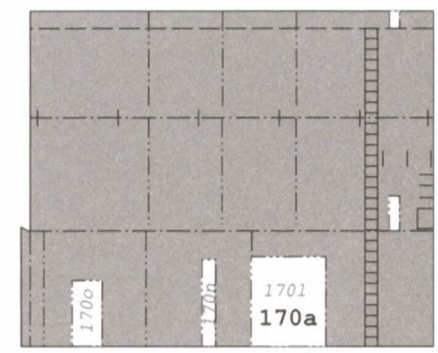
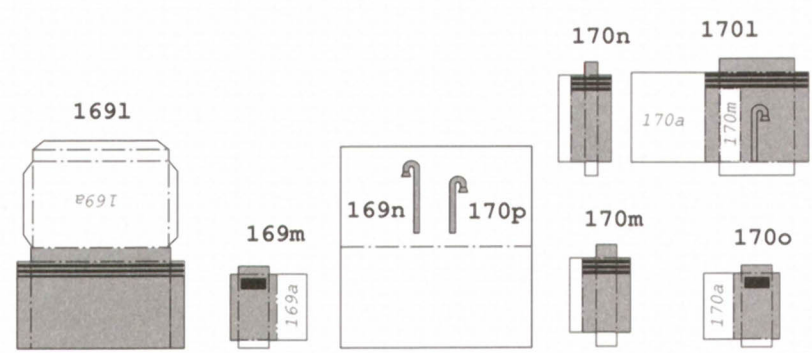
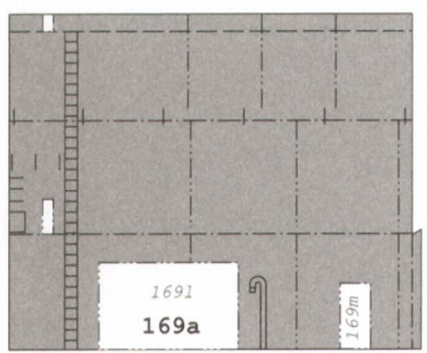
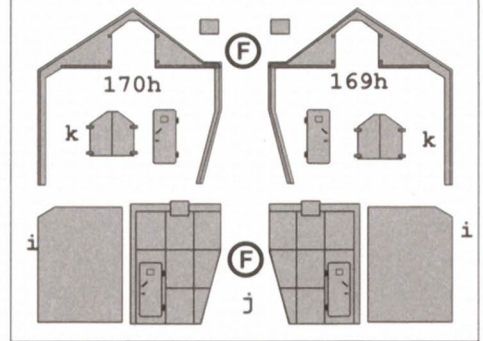
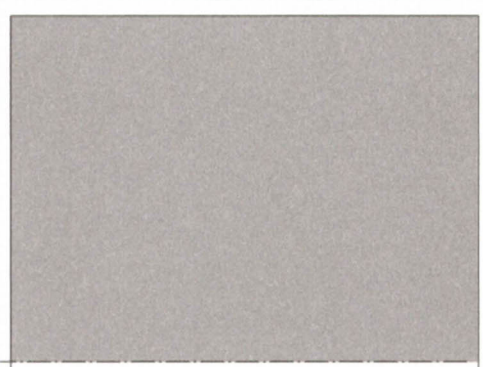
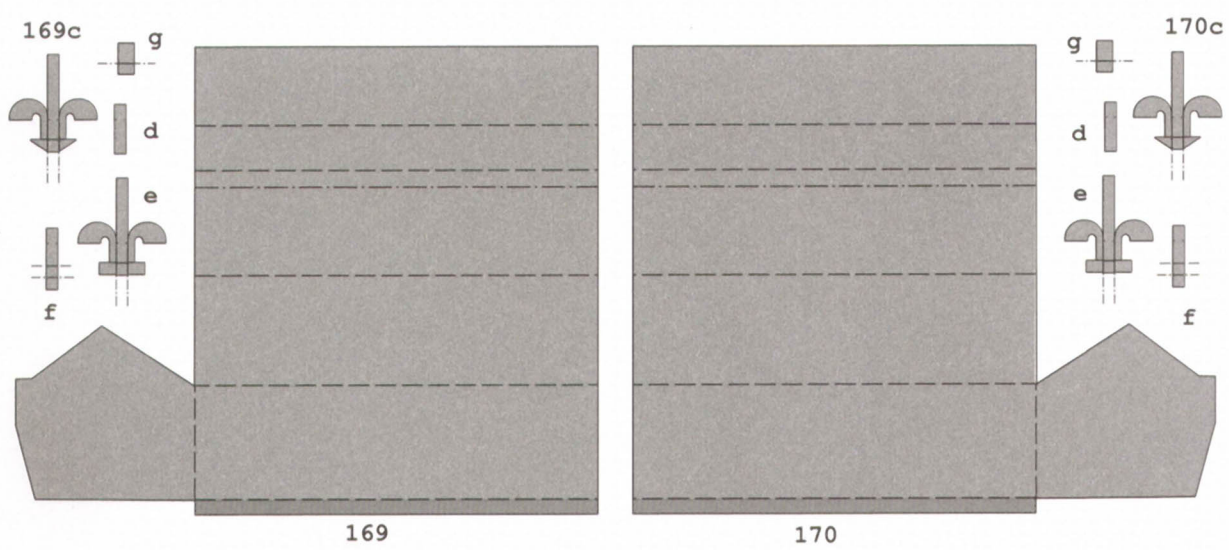
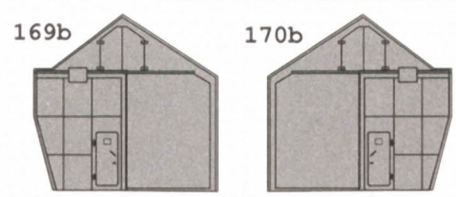
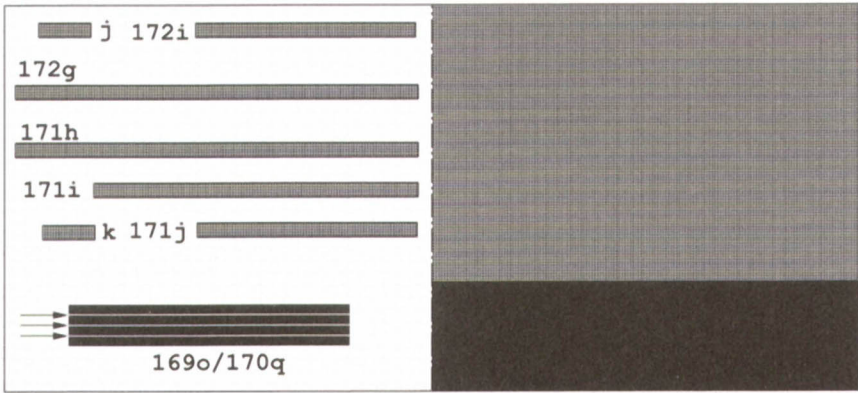
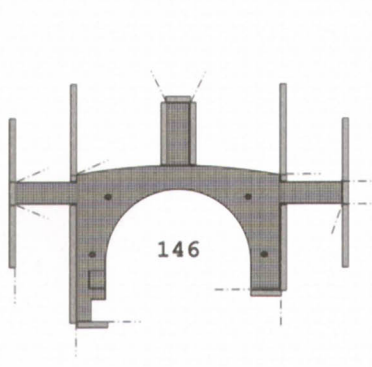
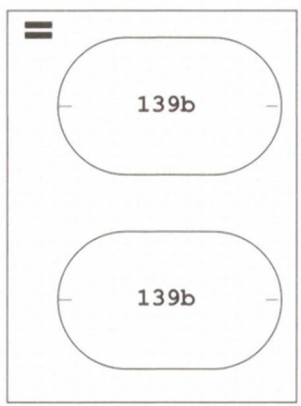
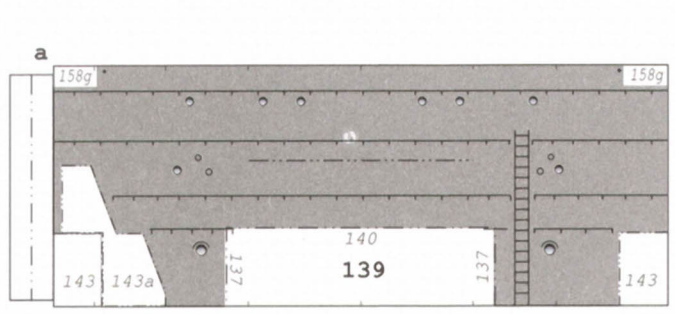
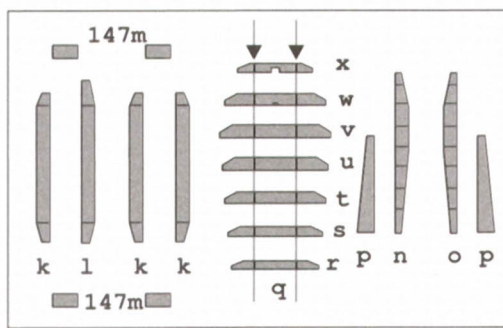
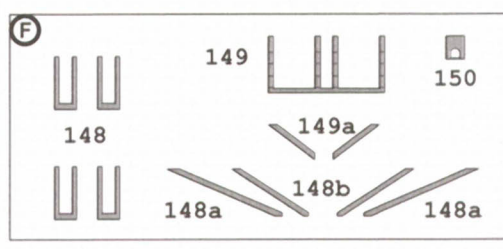
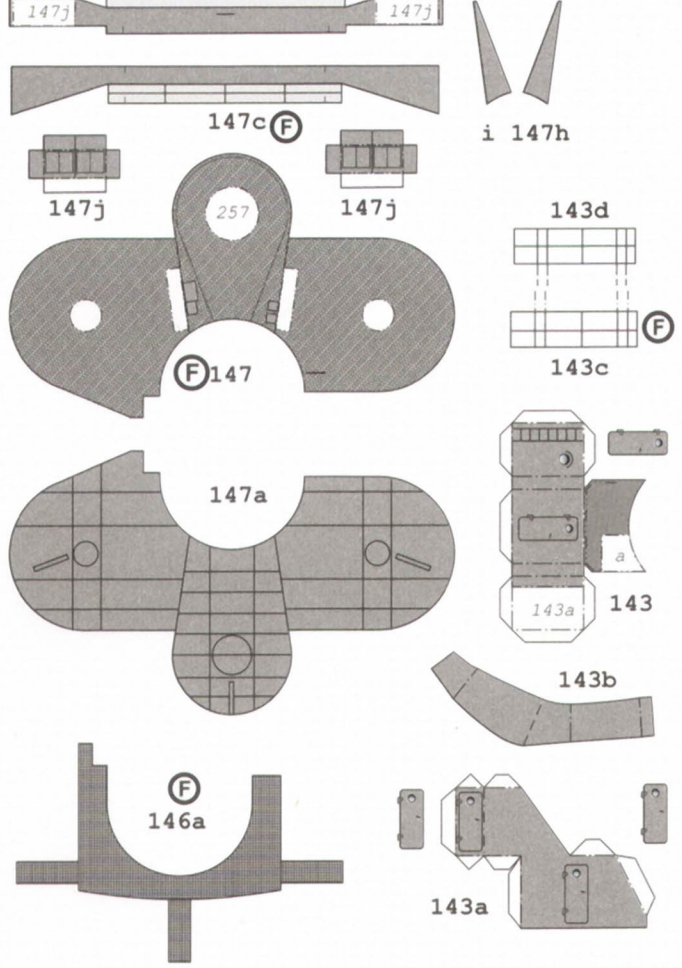
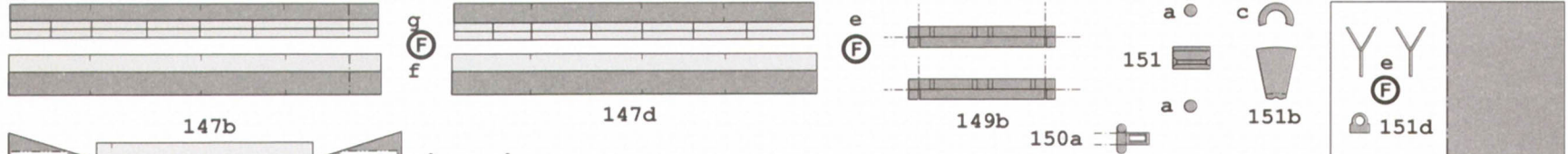

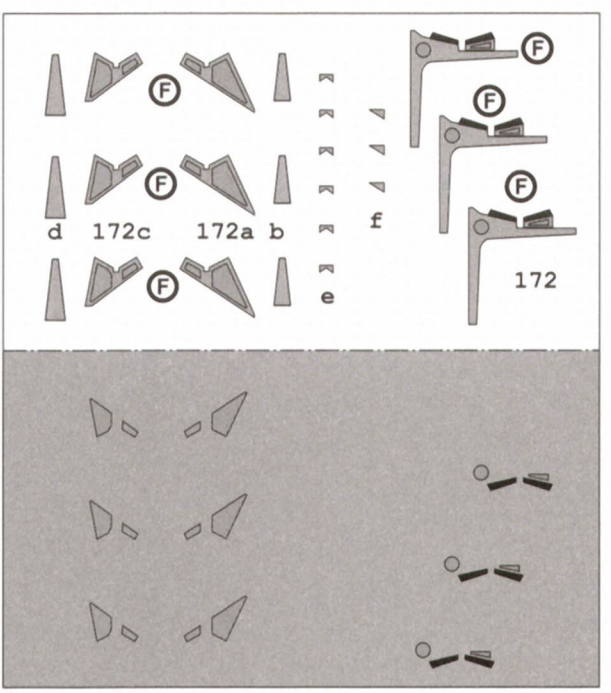
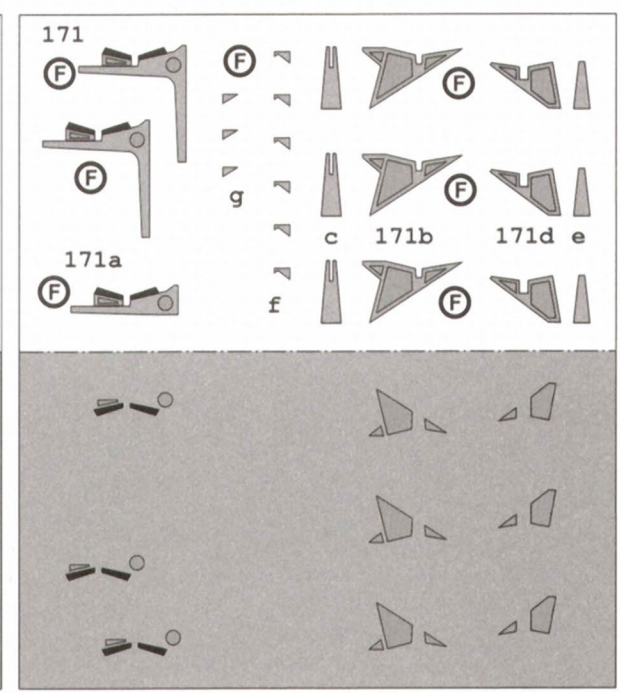
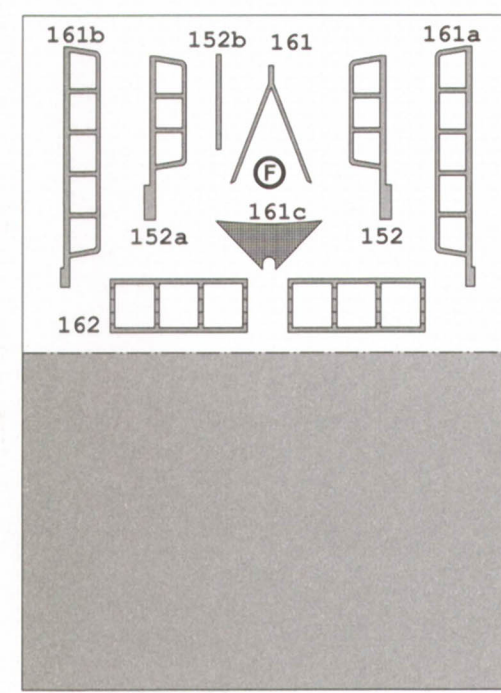
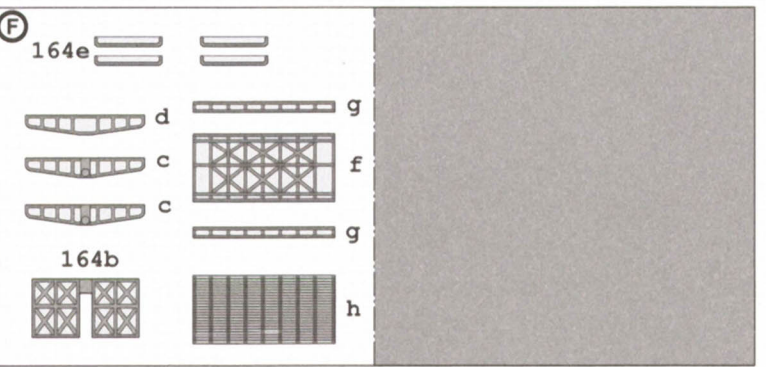
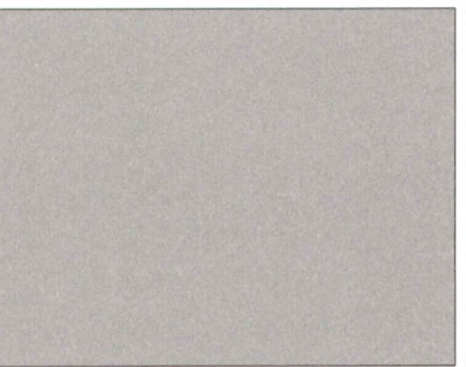
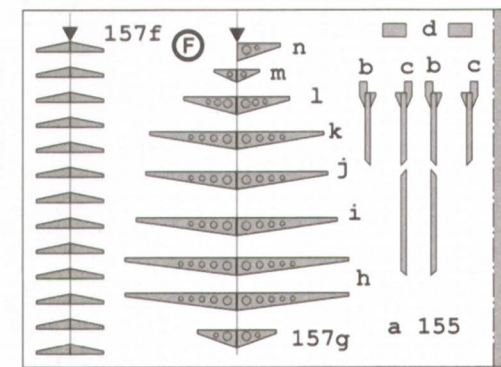
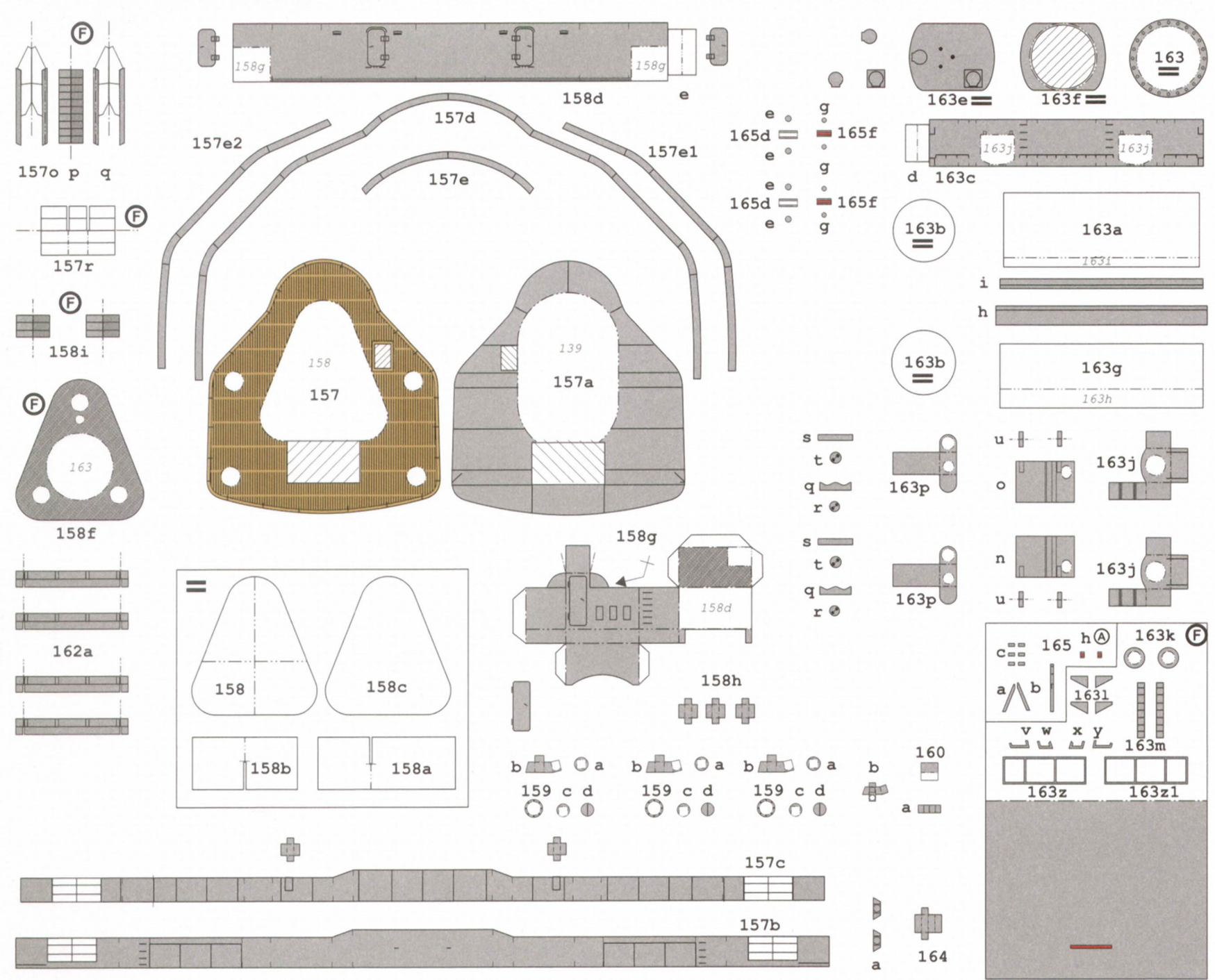

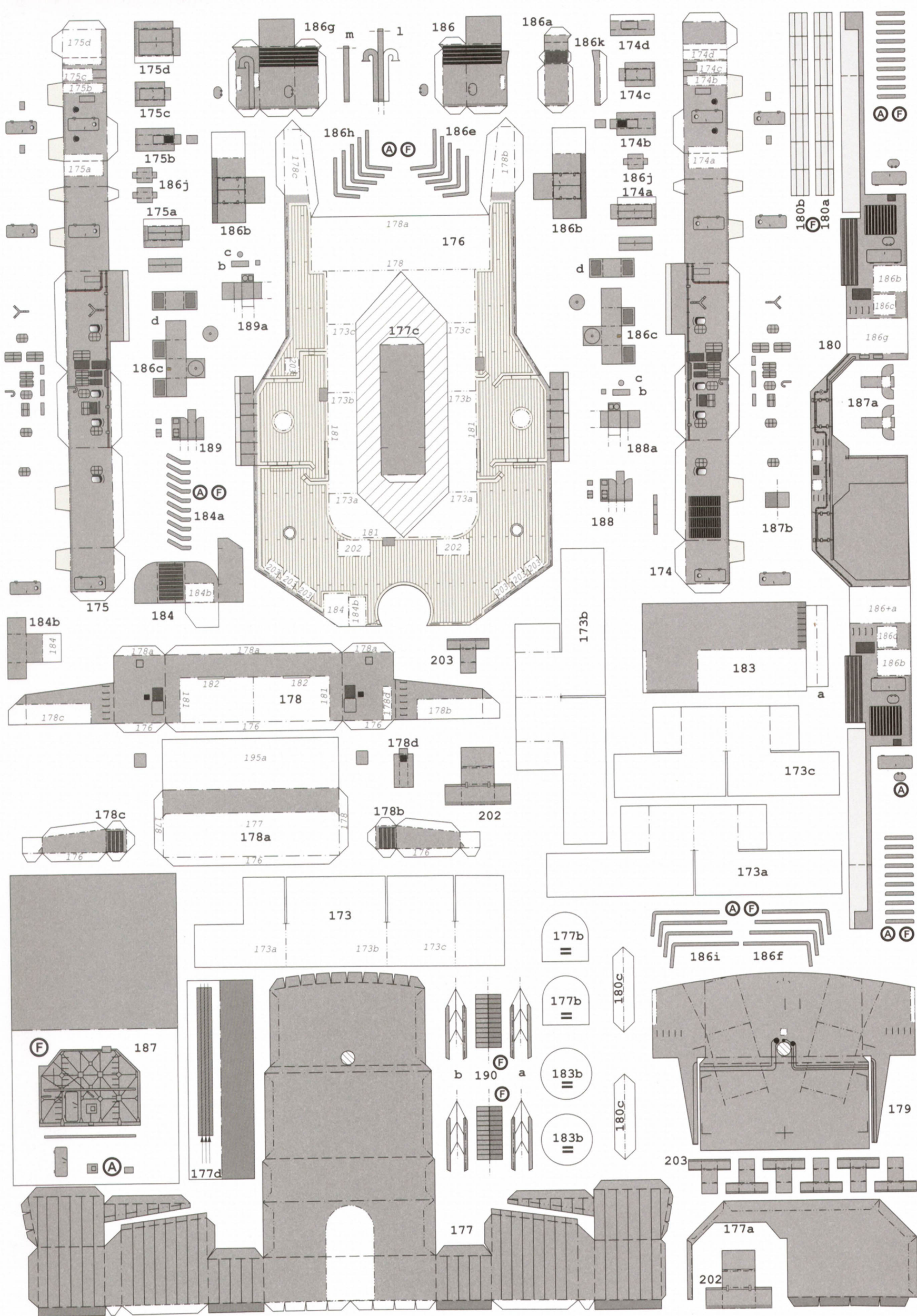

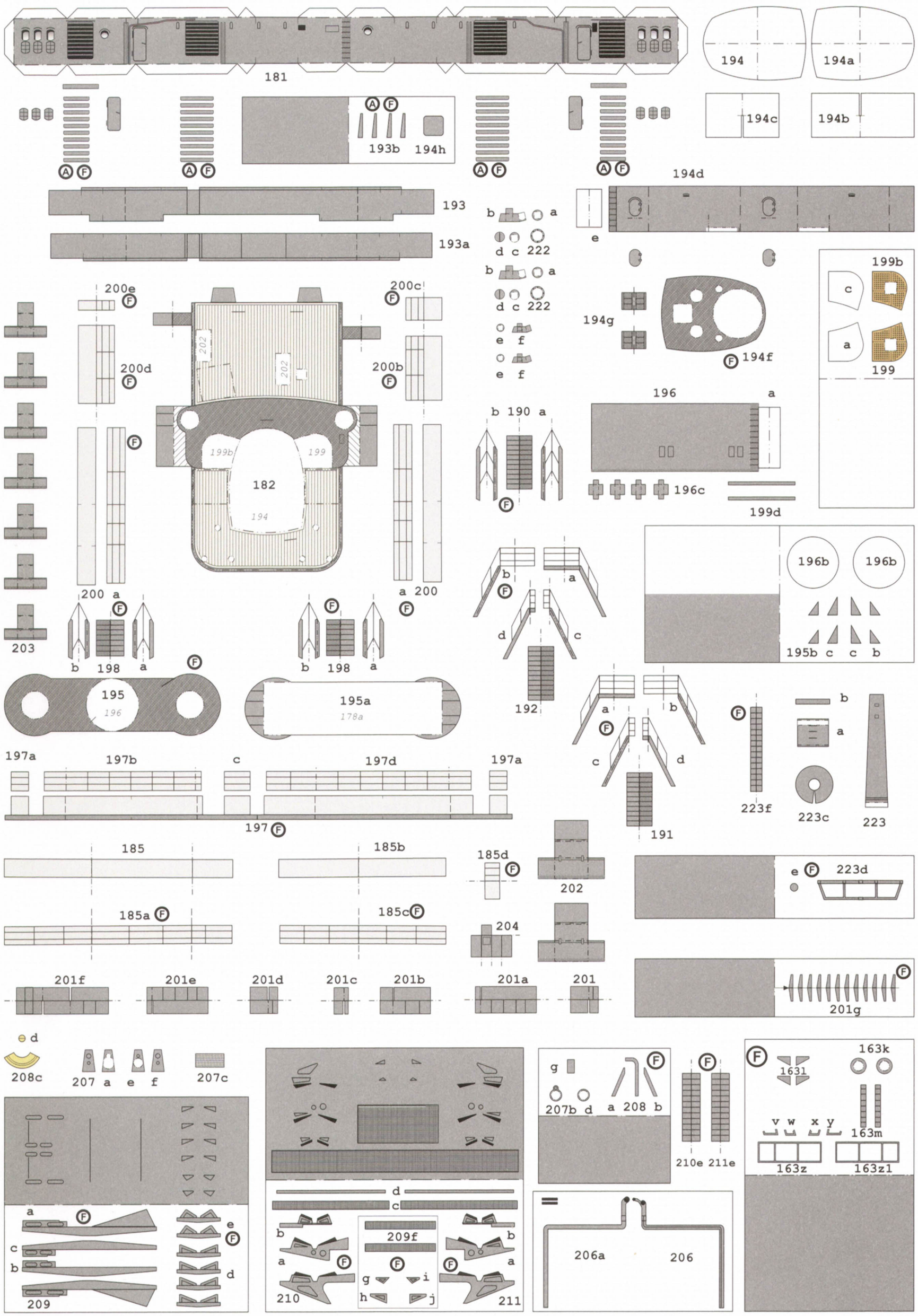

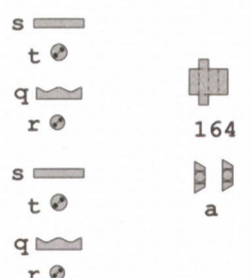
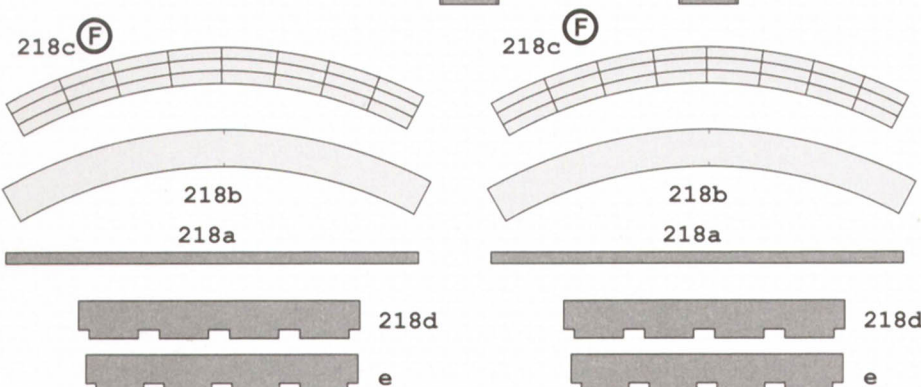
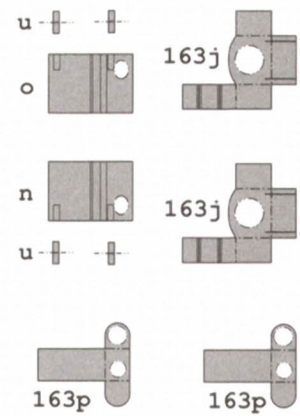
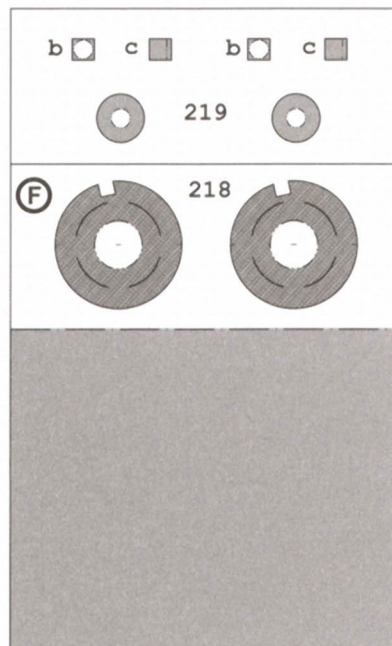
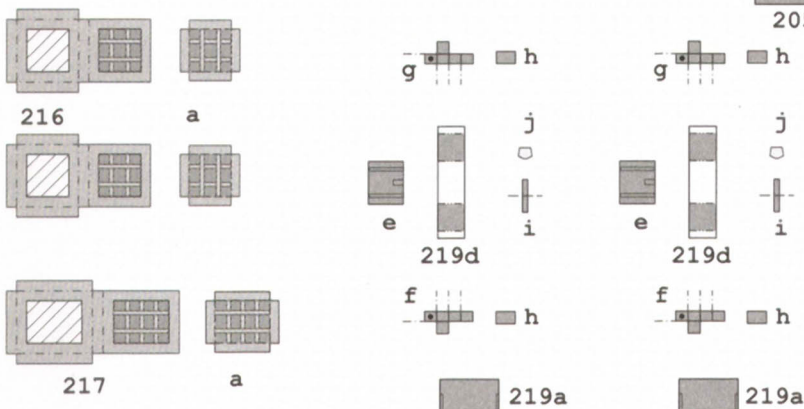
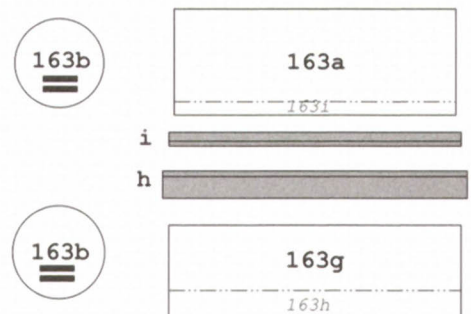
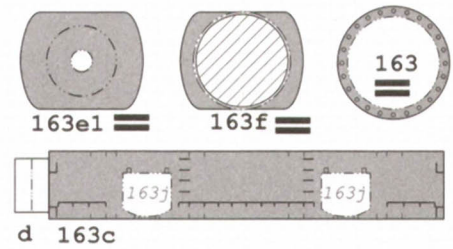
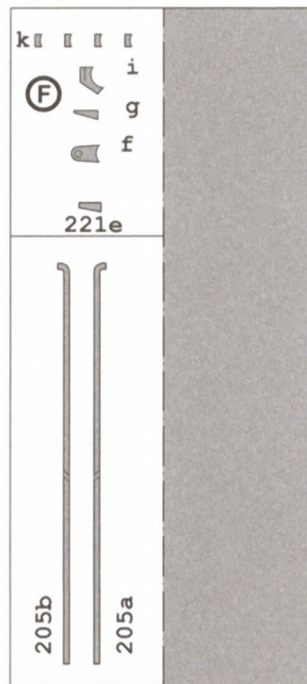
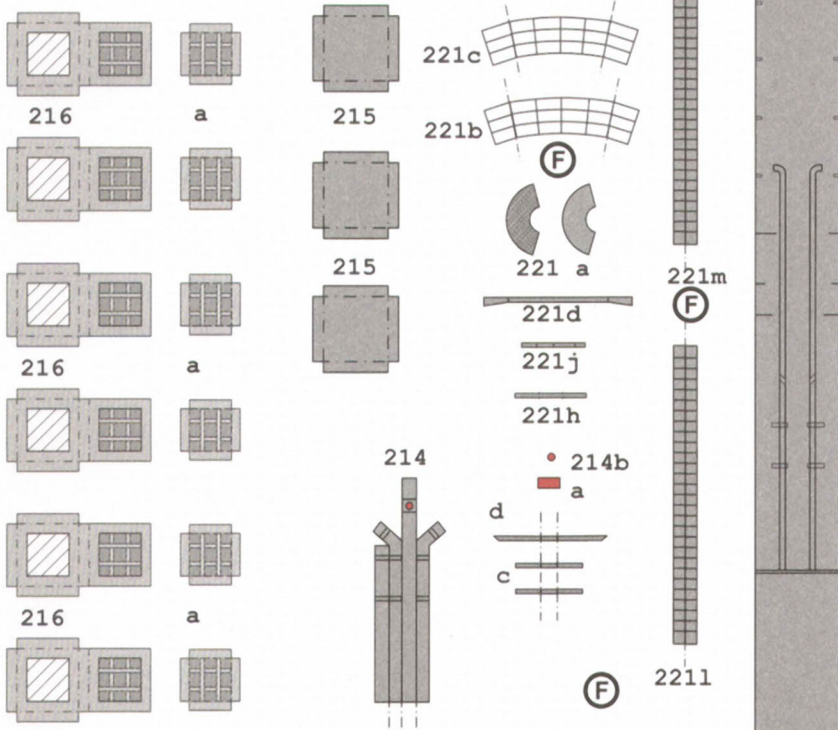
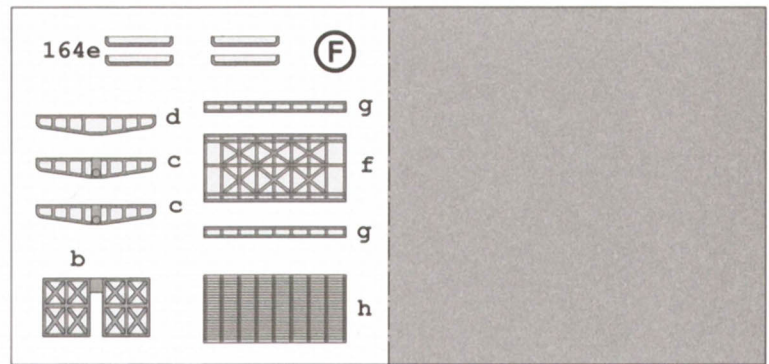
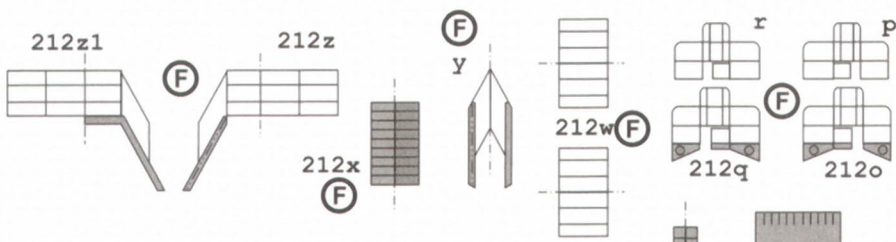
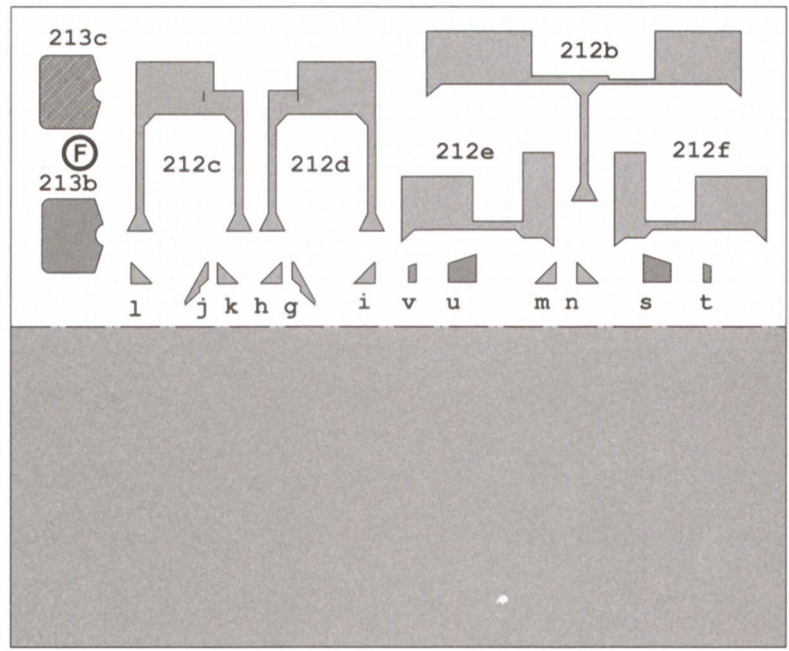
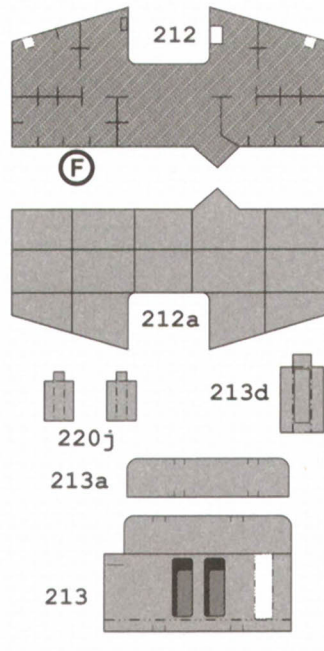
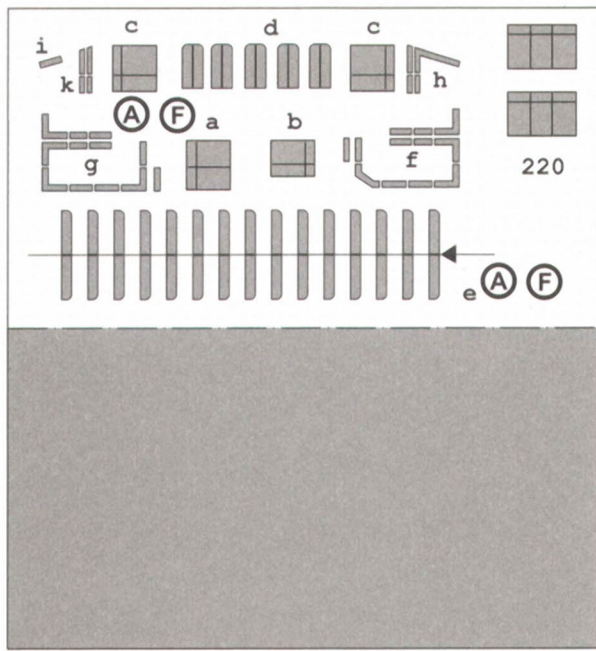

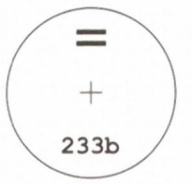
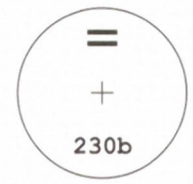
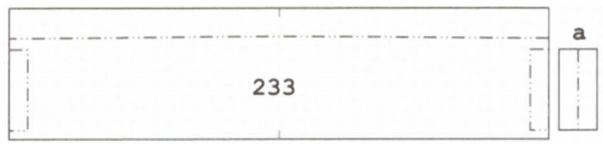
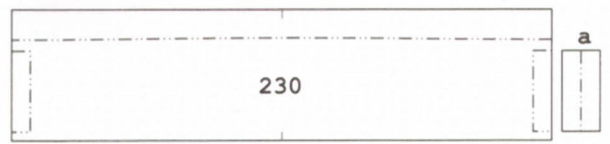
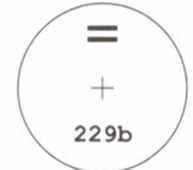
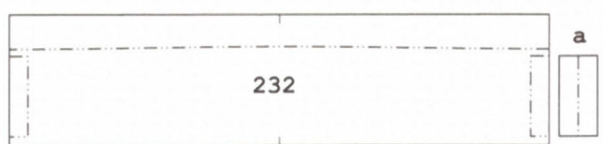
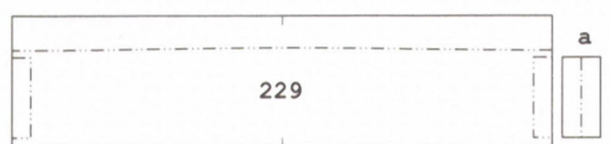
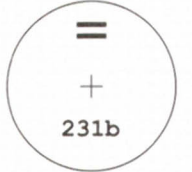
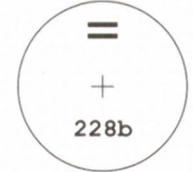
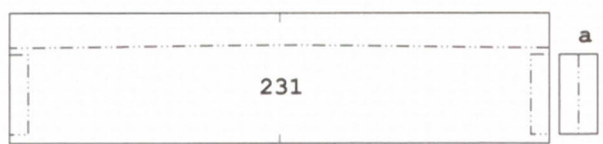
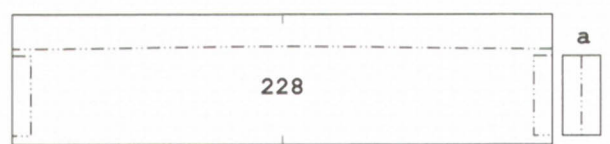
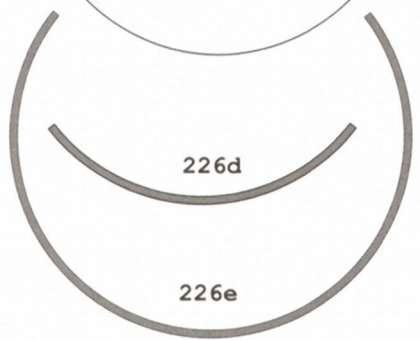
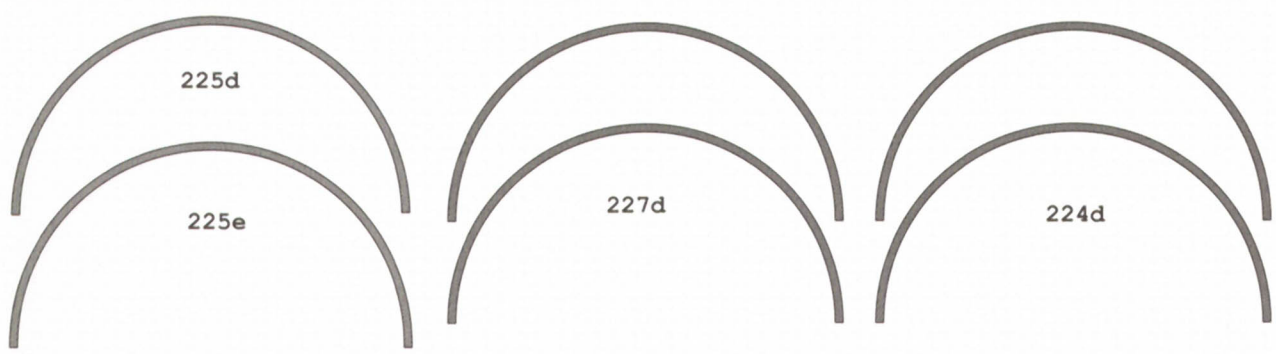
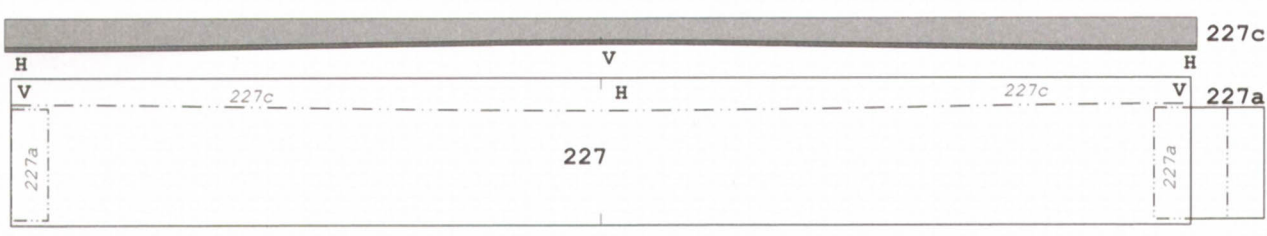
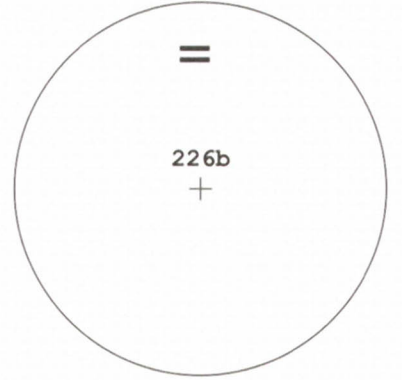
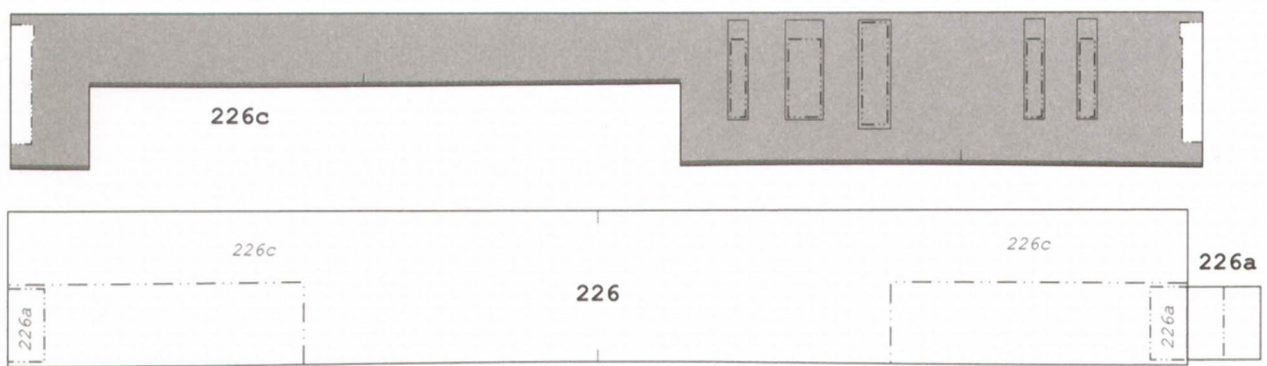
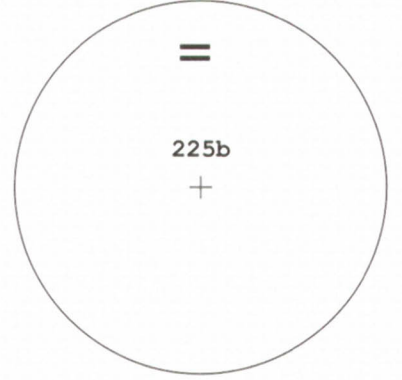
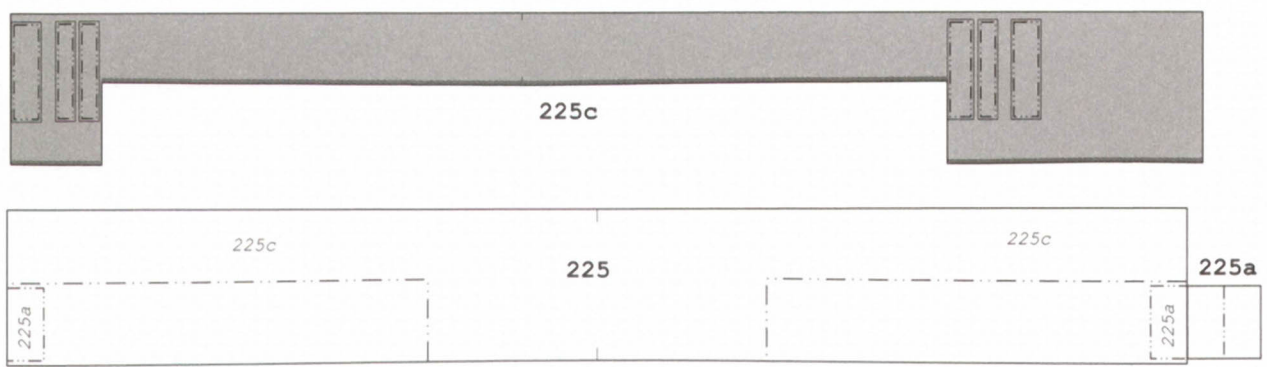
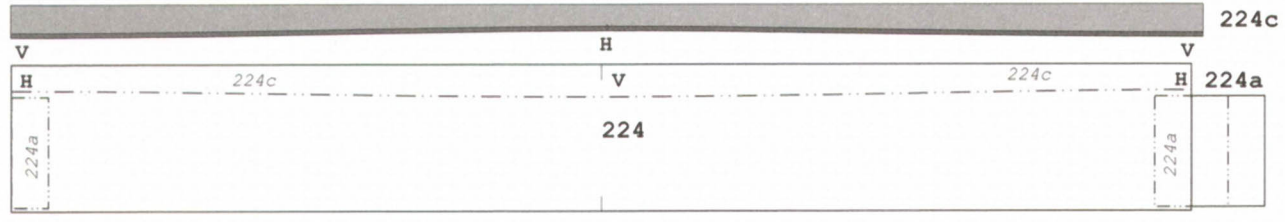

258a

Draht 0,5mmø, L=8,5mm

2cm-Heeresflak C38

258c

258k

258a

Draht 0,5mmø, L=8,5mm

2cm-Heeresflak C38

258c

258k

242a

242

242a

242b

F

235

234

241e

241c

241d

241f

241a

241b

241

240b

240c

240

240a

240d

241g

F

238o p q

239g

236h i j

237k l m

A

A

A

A

238

238c

238i

239e

239d

239b

239a

237

237b

237f

237h

236f

236d

236b

236

238n

238m

238m1

237j

236k

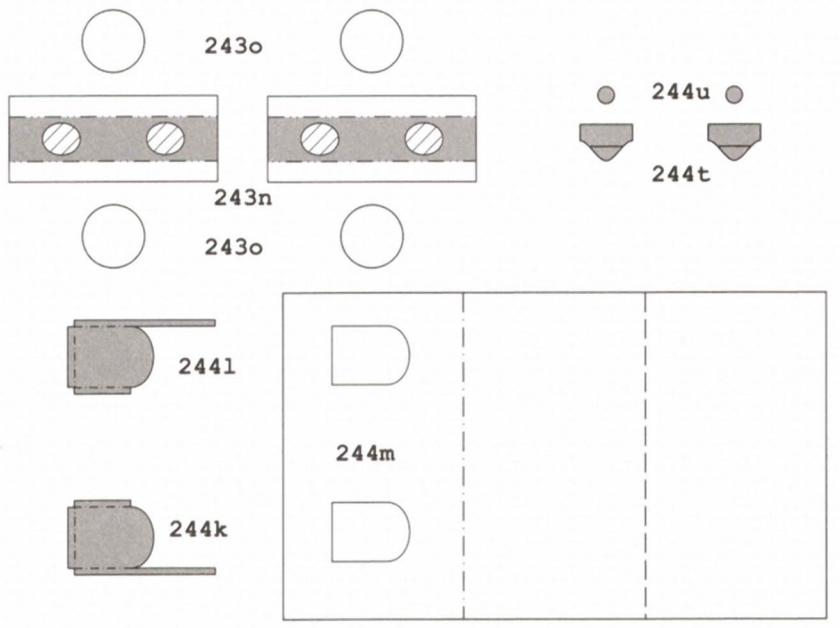
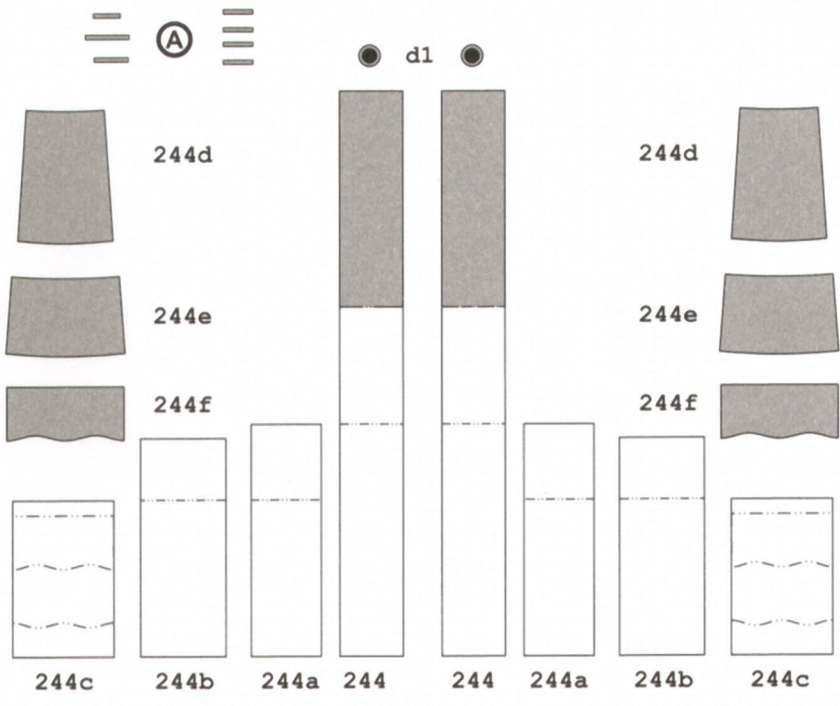
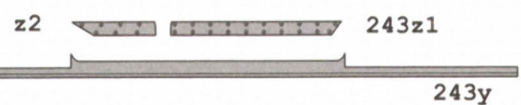
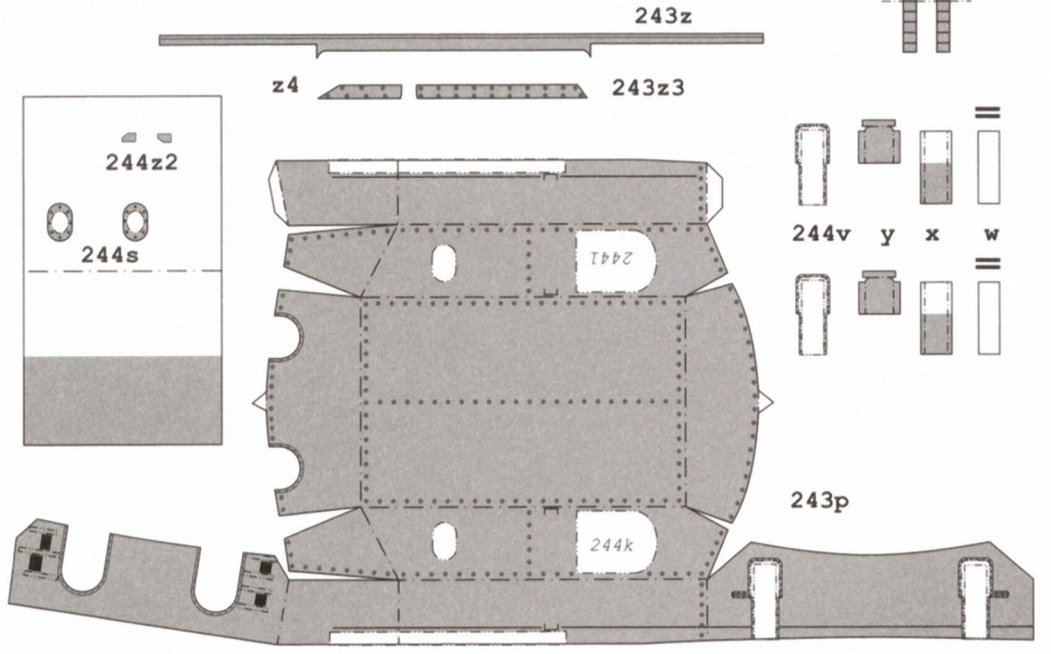
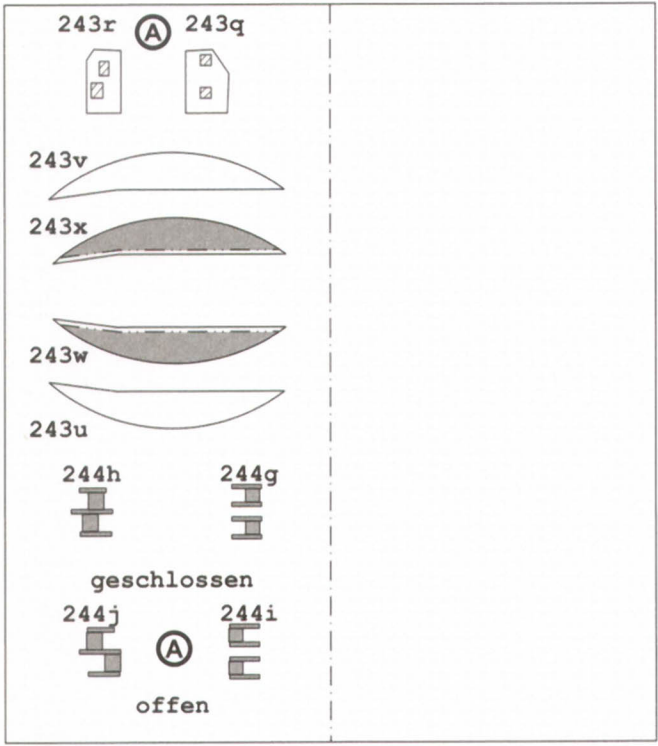
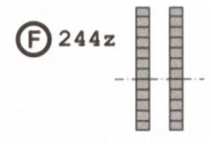
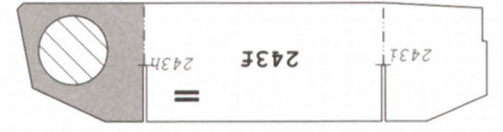
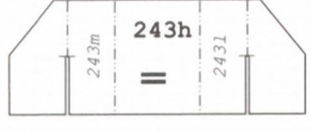
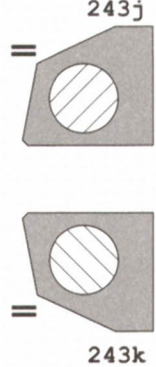
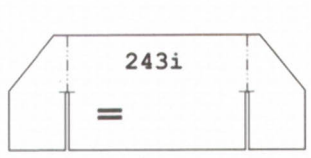
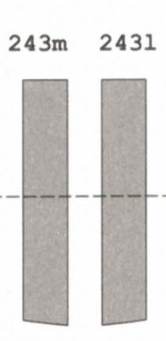
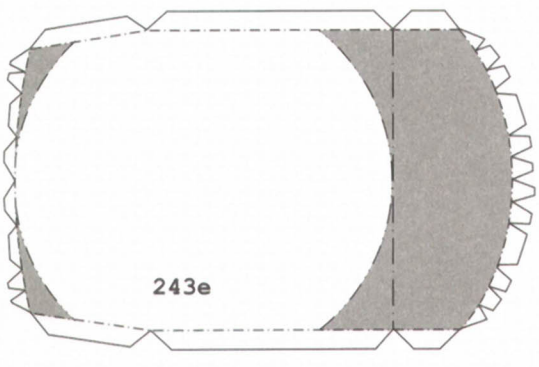
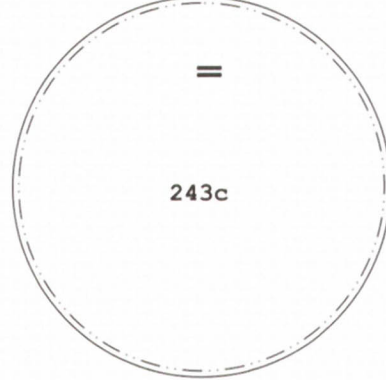
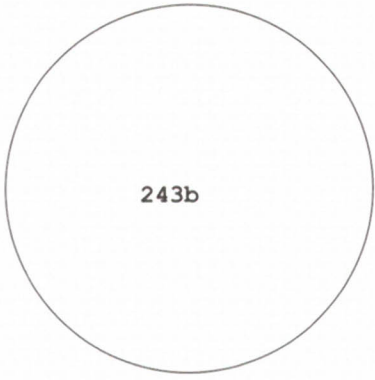

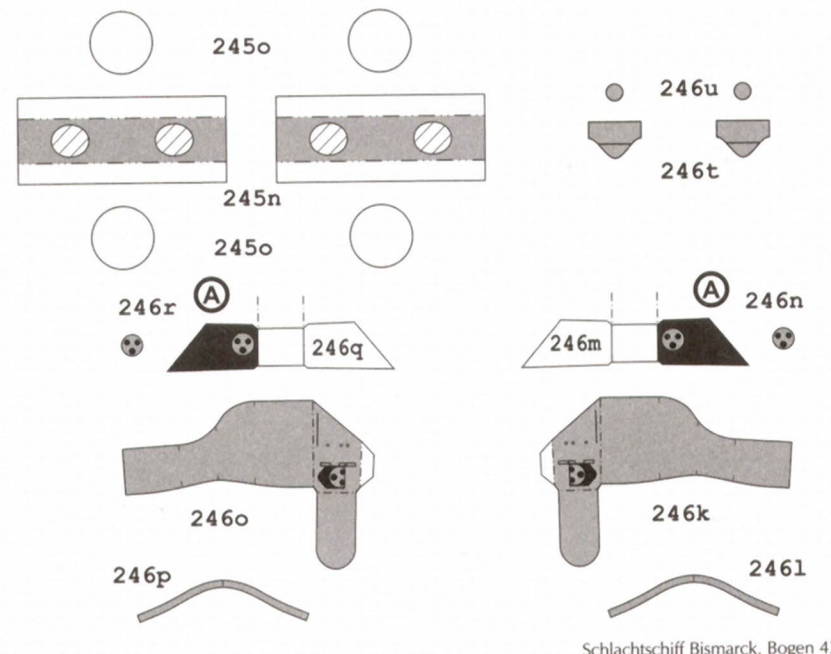
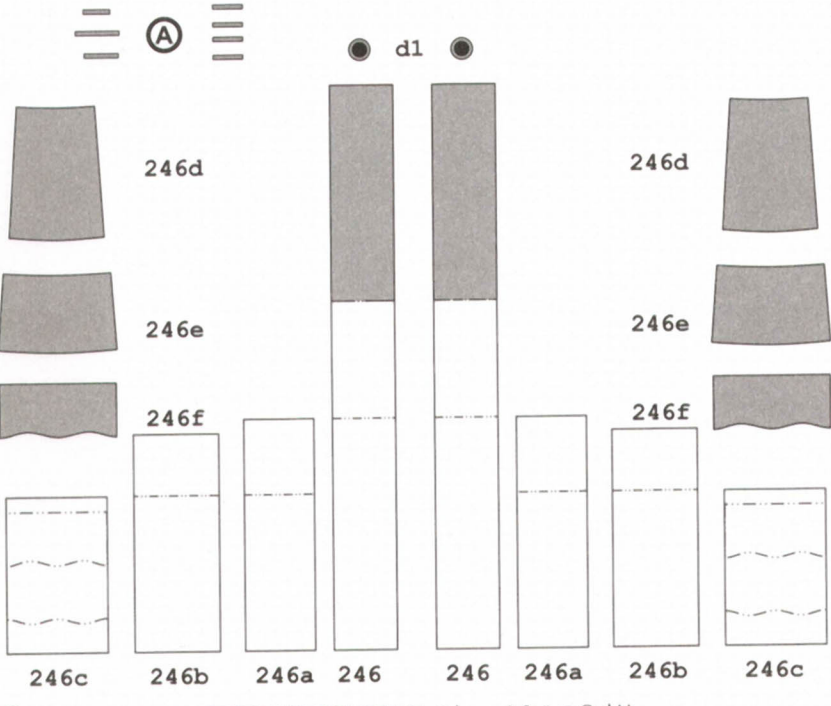
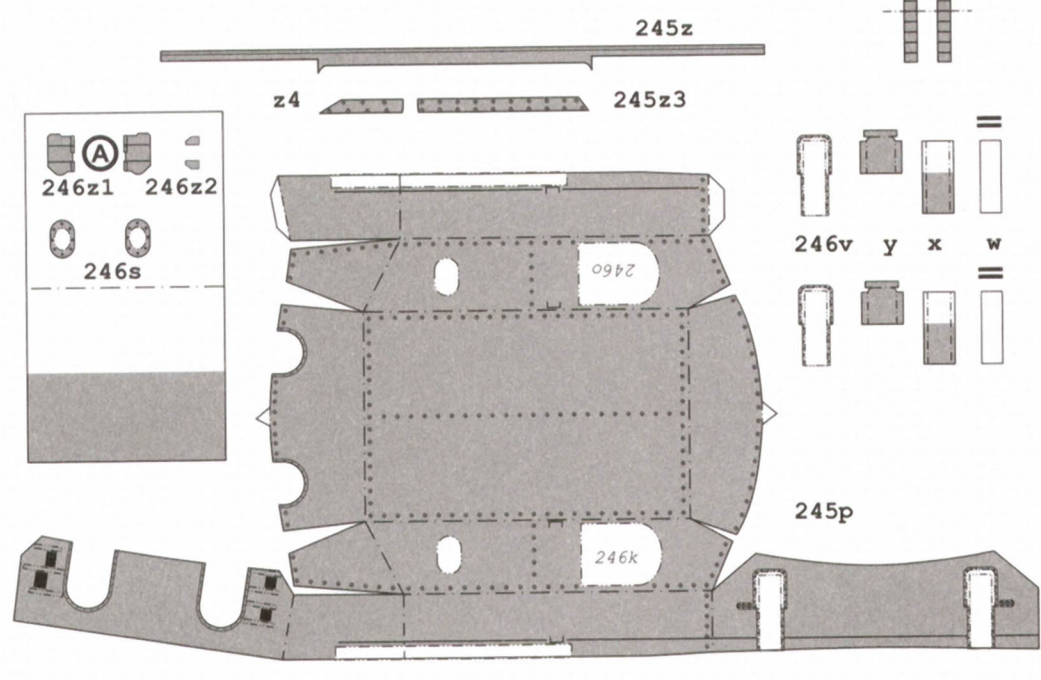
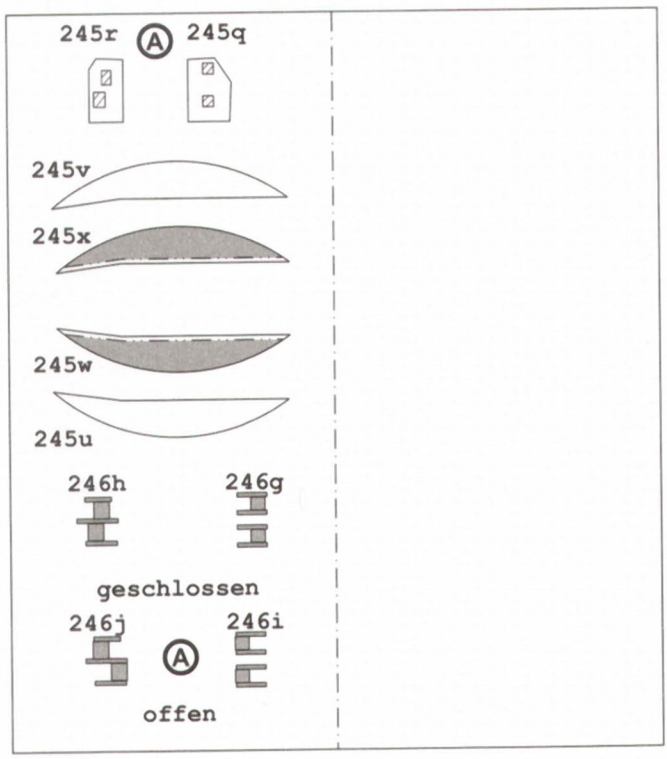
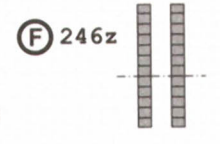
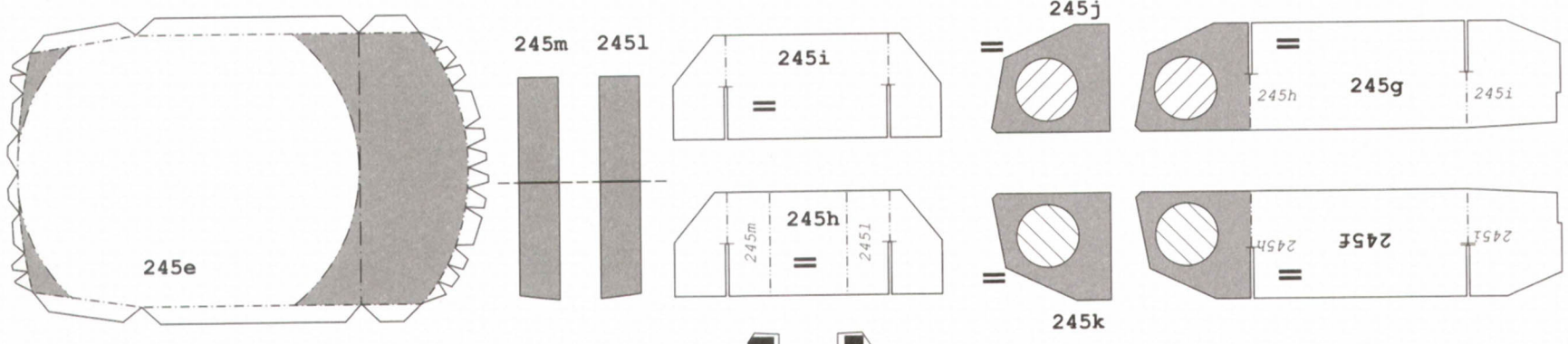
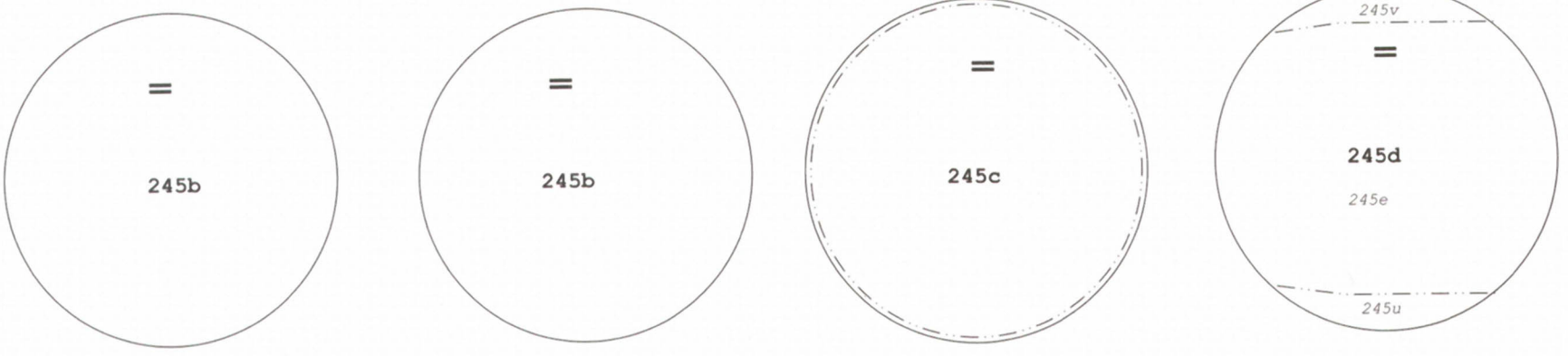
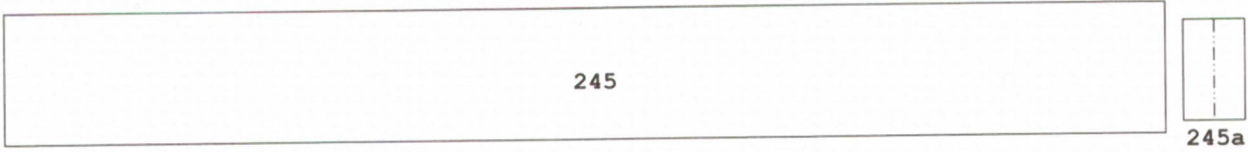

247



247a



247b

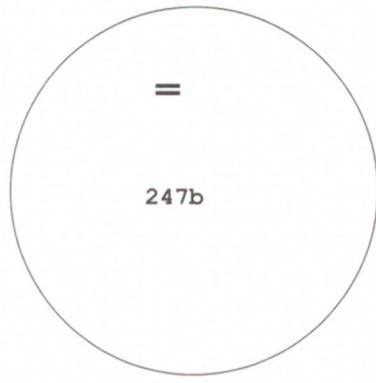

247b

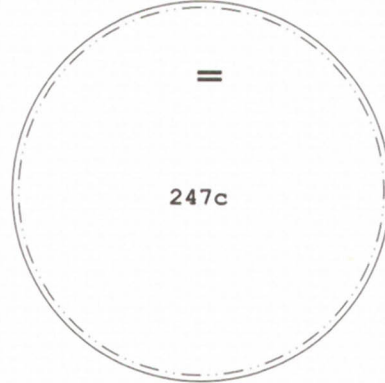

247c



247d

247e

247u

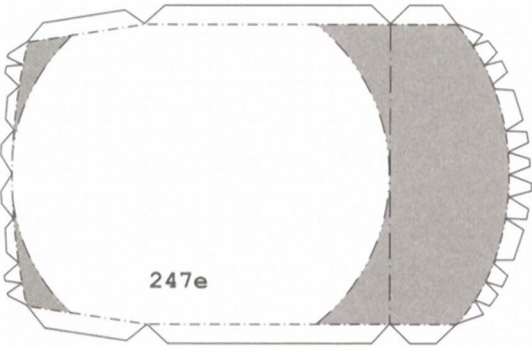

247e

247m 247l

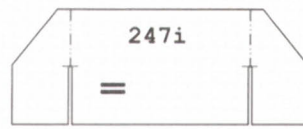

247i

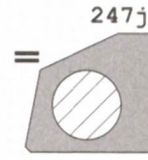

247j



247h

247g

247i

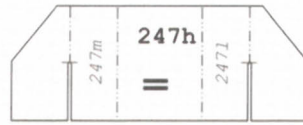

247h

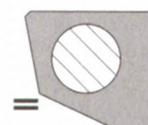

247k

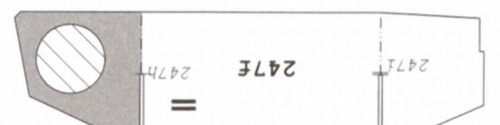

247f

247i

247t (A) 247s

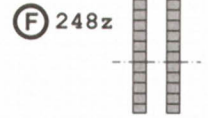

(F) 248z

247r (A) 247q

247v

245x

247w

247u

248h

248g

geschlossen

248j (A) 248i

offen



247z



z4

247z3

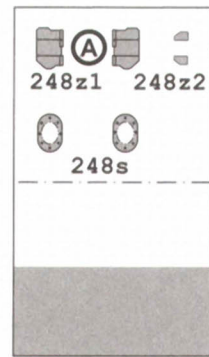

(A) 248z1 248z2

248s

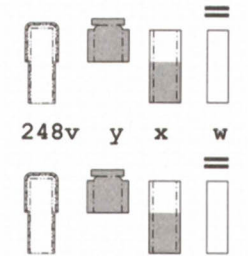

248v

y

x

w

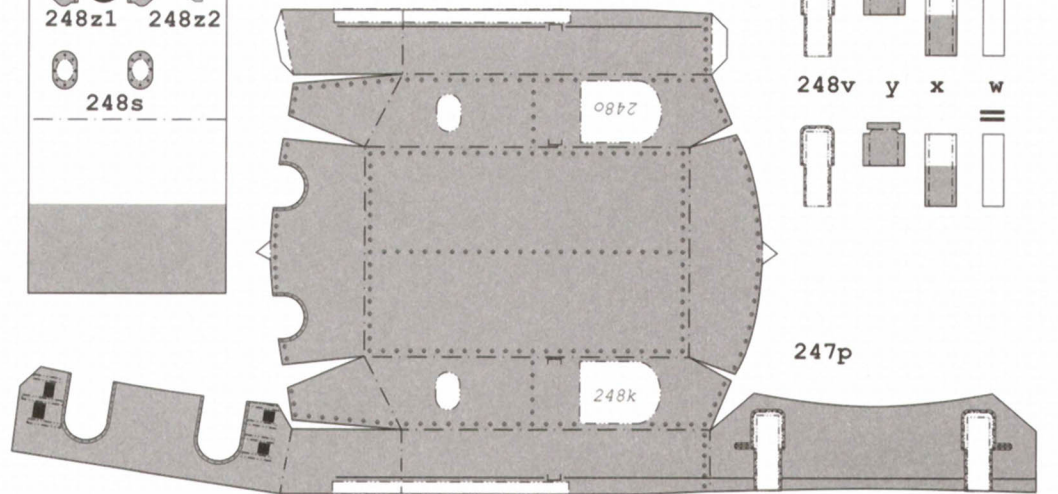

247p



z2

247z1



247y



d1

248d

248e

248f

248c

248b

248a

248

248

248a

248b

248c



247o

247n

247o

248r (A)

248q

248u

248t

(A) 248n

248m

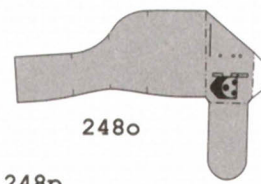

248o

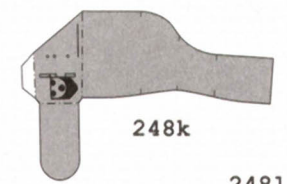

248k



248p



248l

249



249a



249b

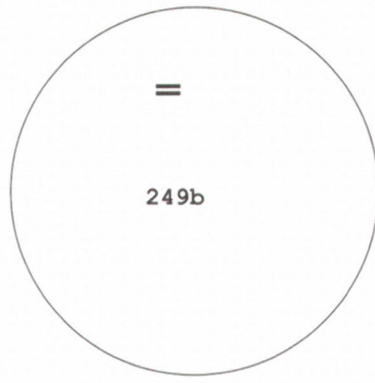

249b

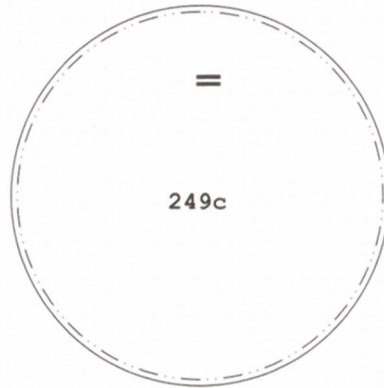

249c



249d

249e

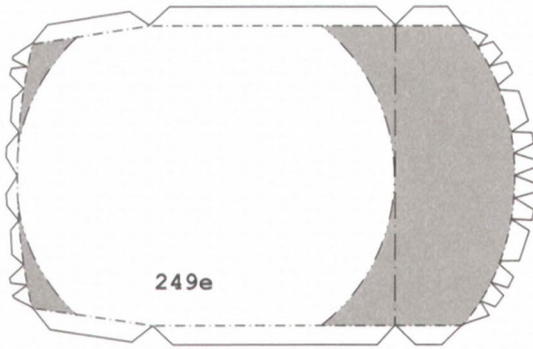

249e

249m 249l

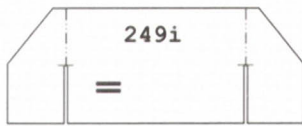
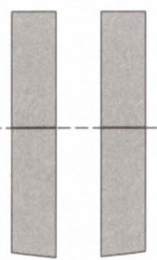

249i

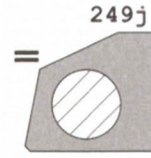

249j

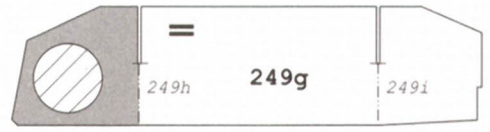

249g

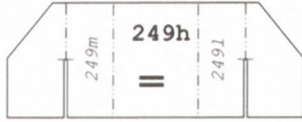

249h

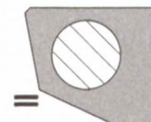

249k

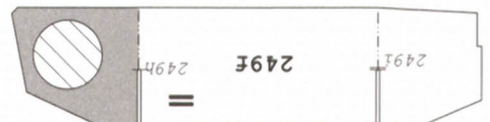

249f

249t



(A)



249s

(F) 250z



249r (A) 249q

249v

249x

249w

249u

250h 250g

geschlossen

250j (A) 250i

offen



249z

z4



249z3

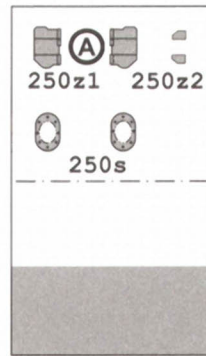

250z1 250z2

250s

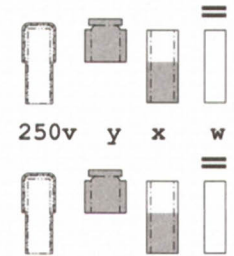

250v

y

x

w



249p

z2



249z1



249y

(A)

d1

250d

250e

250f

250c 250b 250a 250 250 250a 250b 250c

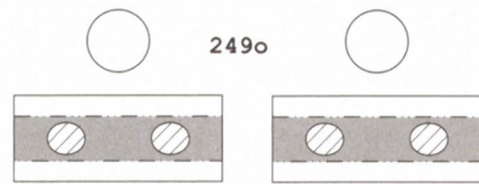

249o

249n

249o

250r (A)



250q

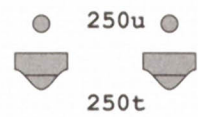

250u

250t

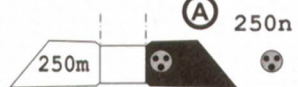

250m

(A) 250n

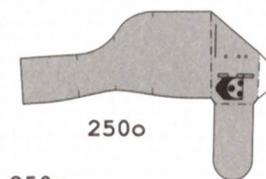

250o

250p

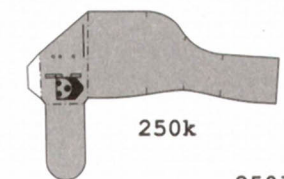

250k

250l

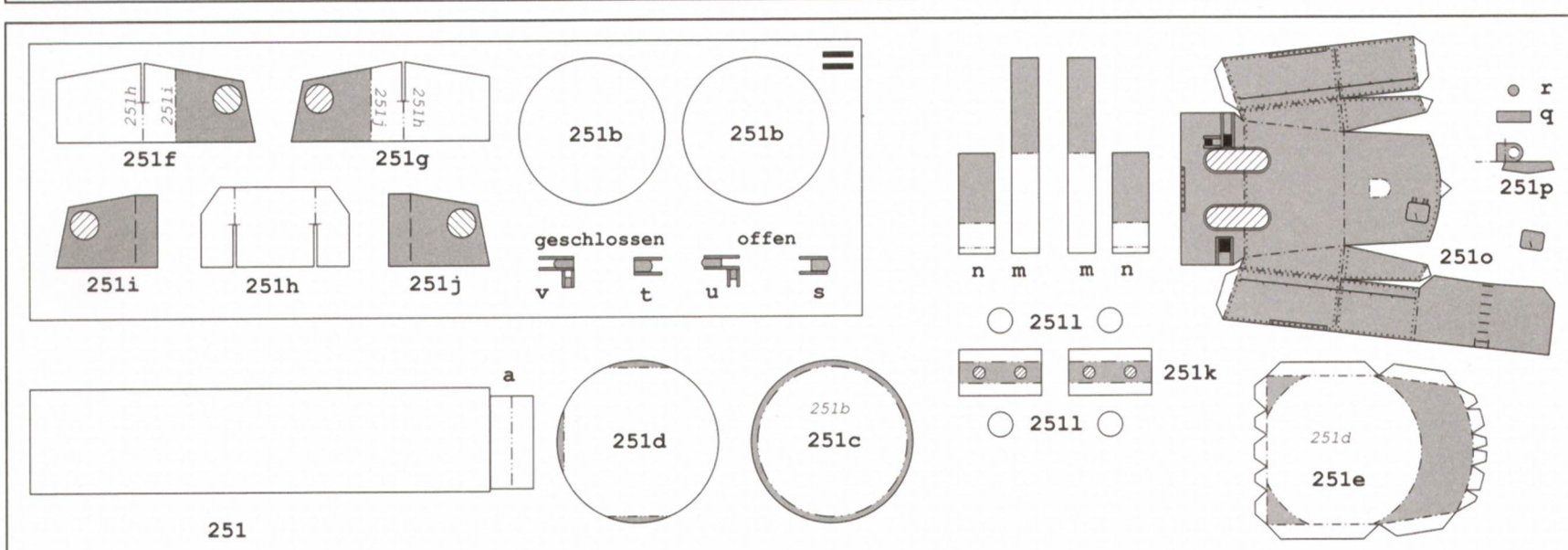
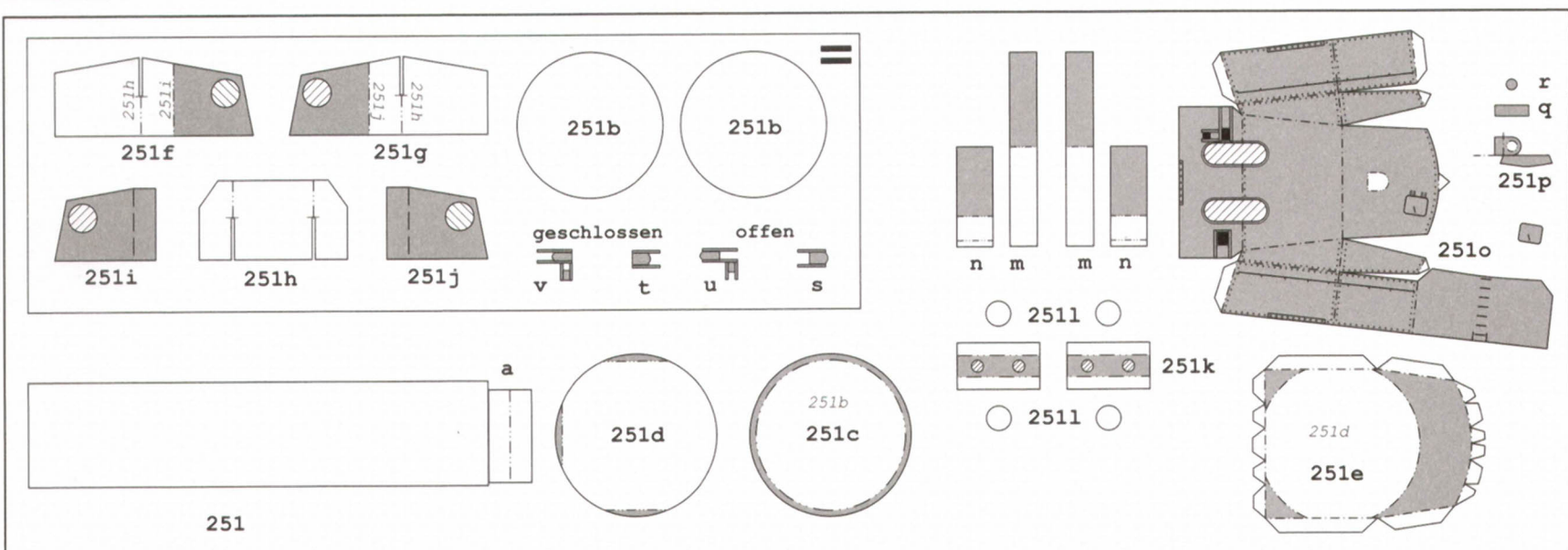
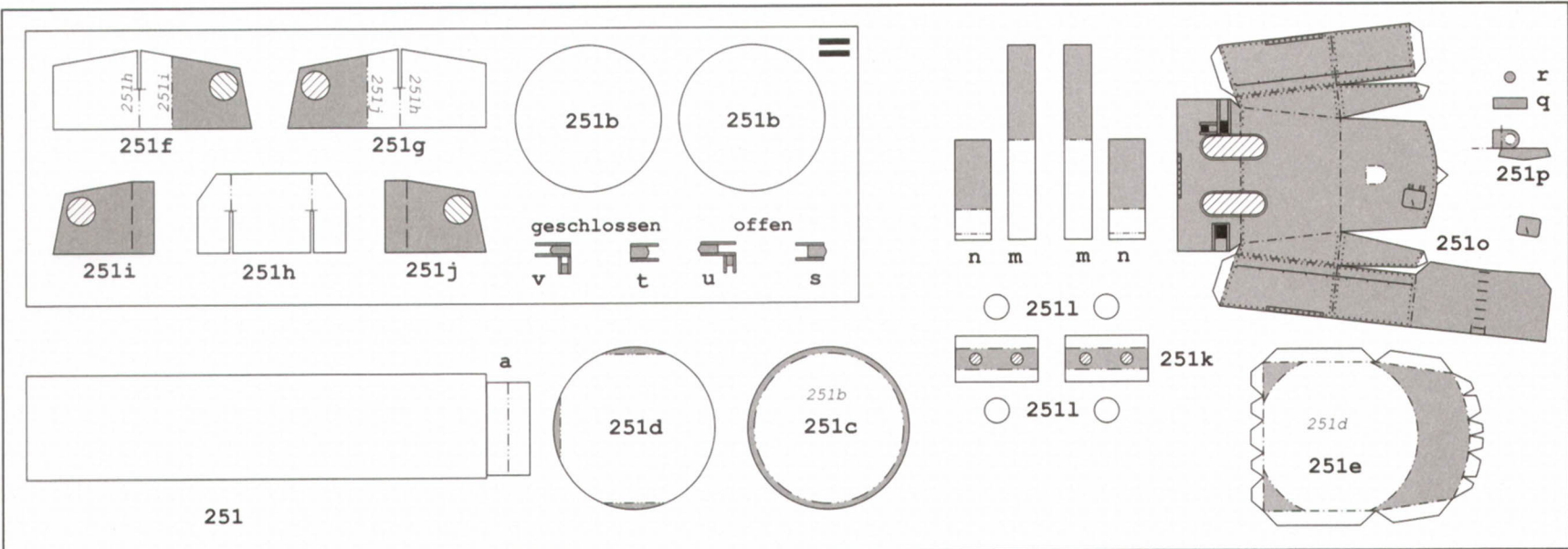
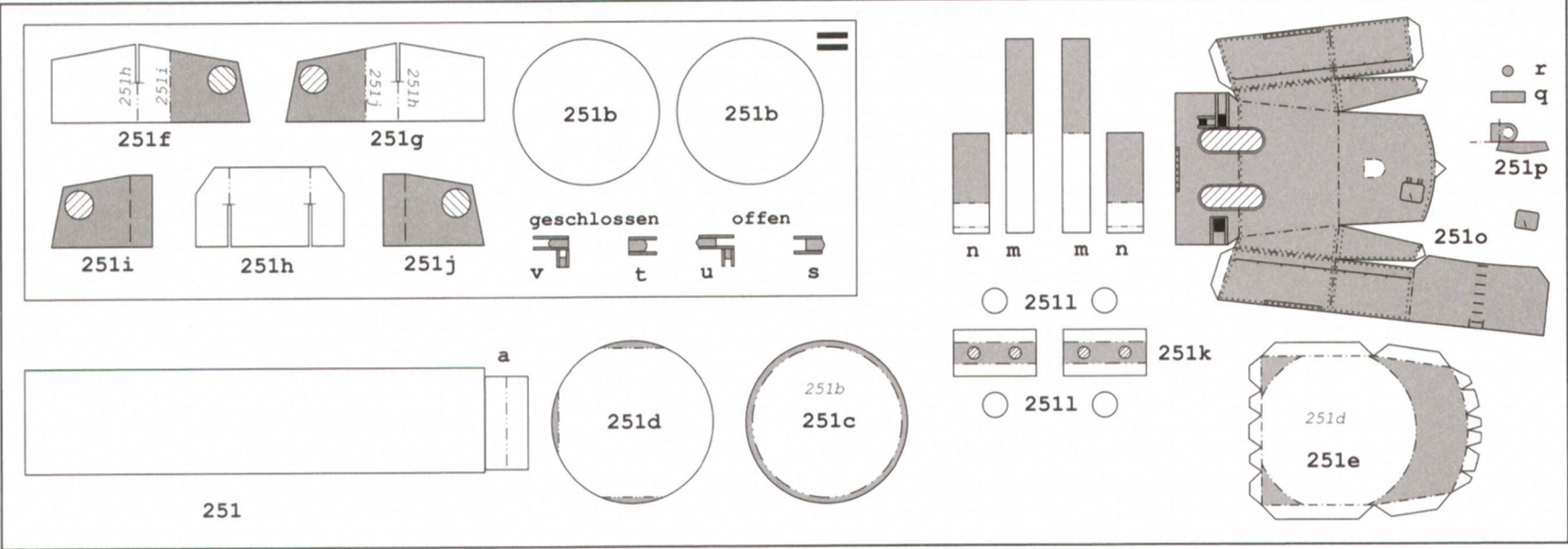

10,5cm-Flak C/31

10,5cm-Flak C/31

252f

252f

10,5cm-Flak C/31

Parts shown: 253, 253a, 253u, 253u1, 253d, 2531, t, o, s, r, q, p, n, v1, w, z1, z2, z, z10, z11, z8, z9, z5, z6, z4, z7, z3, y, h, x, v, k, g, f, e, c1, c2, c3, b, z, z1, z2, z, z10, z11, z8, z9, z5, z6, z4, z7, z3, y, h, x, v, k, g, f, e.

10,5cm-Flak C/31

Parts shown: 253, 253a, 253u, 253u1, 253d, 2531, t, o, s, r, q, p, n, v1, w, z1, z2, z, z10, z11, z8, z9, z5, z6, z4, z7, z3, y, h, x, v, k, g, f, e, c1, c2, c3, b, z, z1, z2, z, z10, z11, z8, z9, z5, z6, z4, z7, z3, y, h, x, v, k, g, f, e.

10,5cm-Flak C/37

Parts shown: 254, 254a, 254w1, 254w2, 254g, 254o, p, r, h, j, i, m, z2, z5, z6, z4, z3, y, x, n, z1, z6, z, z1, z2, z, z10, z11, z8, z9, z5, z6, z4, z7, z3, y, h, x, v, k, g, f, e.

10,5cm-Flak C/37

Parts shown: 254, 254a, 254w1, 254w2, 254g, 254o, p, r, h, j, i, m, z2, z5, z6, z4, z3, y, x, n, z1, z6, z, z1, z2, z, z10, z11, z8, z9, z5, z6, z4, z7, z3, y, h, x, v, k, g, f, e.

10,5cm-Flak C/37

Parts shown: 254, 254a, 254w1, 254w2, 254g, 254o, p, r, h, j, i, m, z2, z5, z6, z4, z3, y, x, n, z1, z6, z, z1, z2, z, z10, z11, z8, z9, z5, z6, z4, z7, z3, y, h, x, v, k, g, f, e.

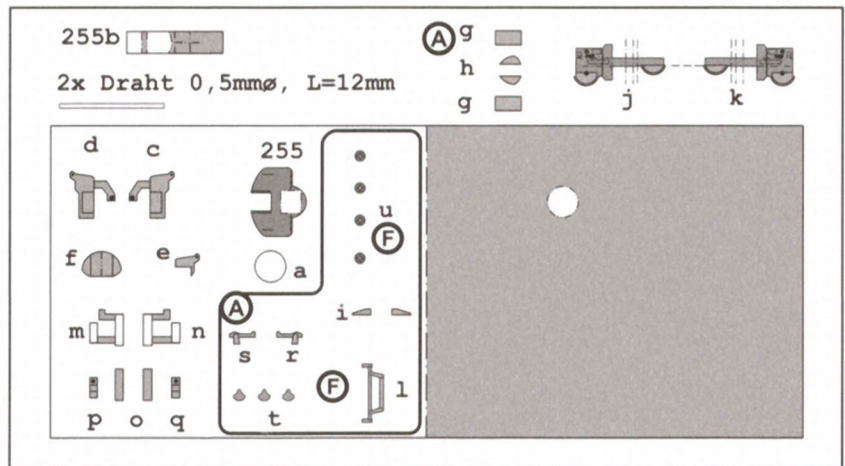
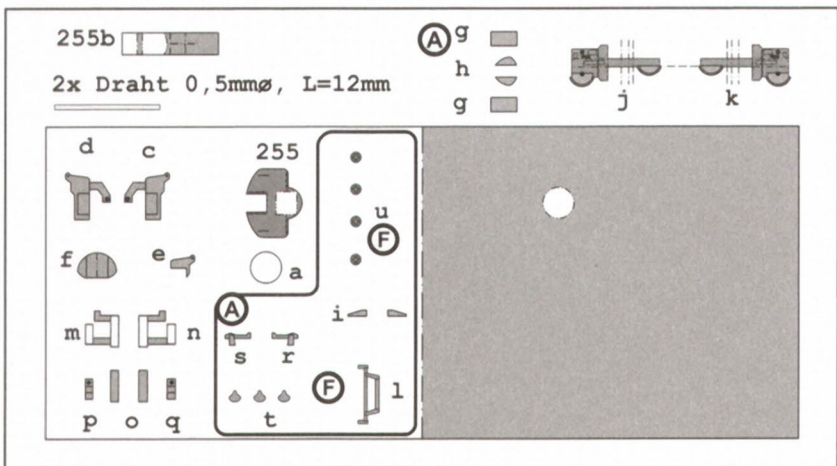
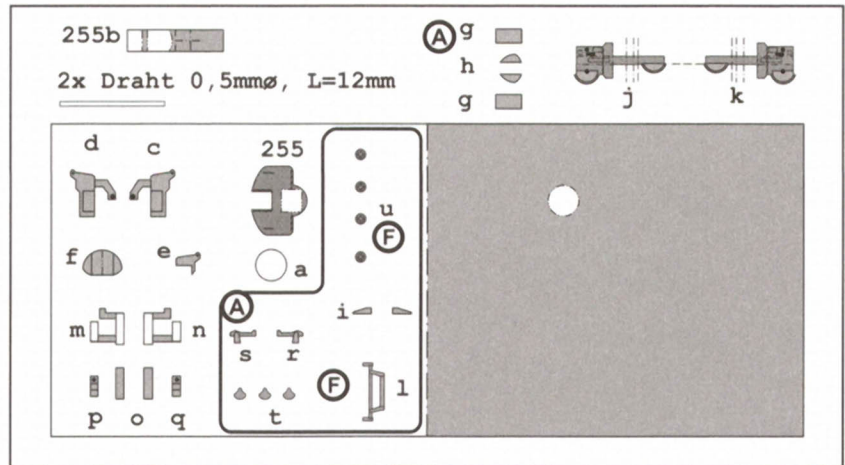
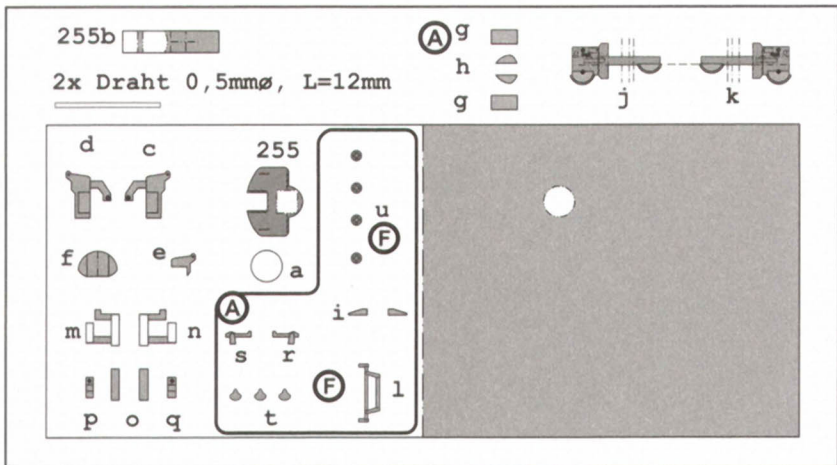
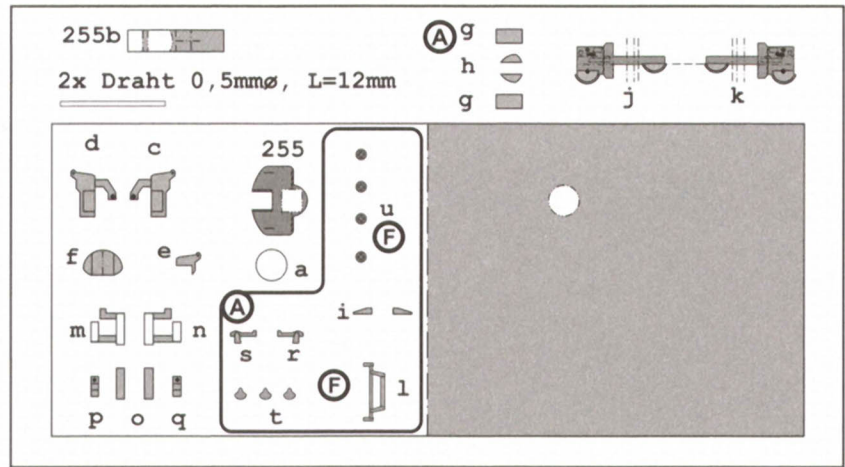
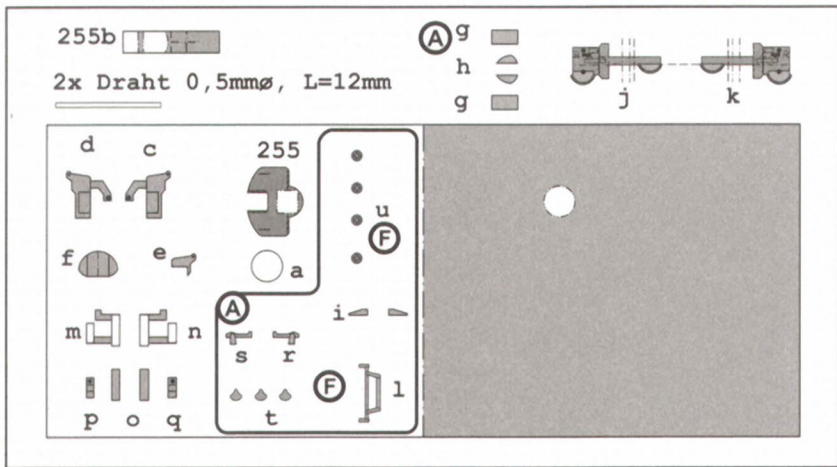
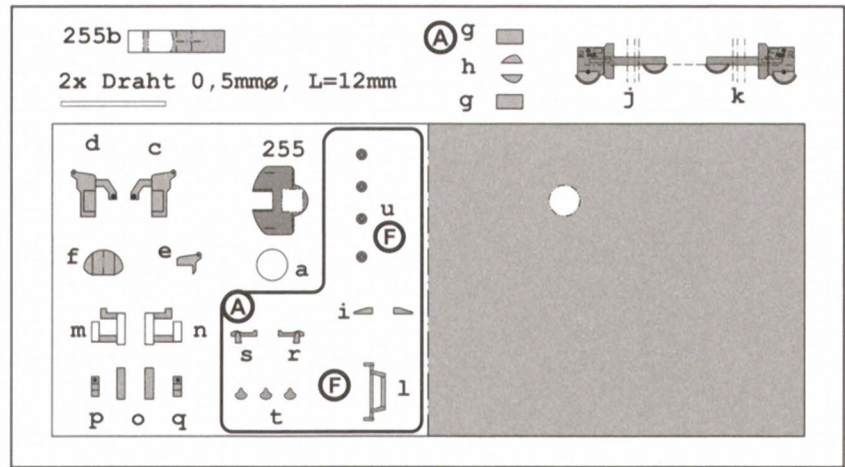
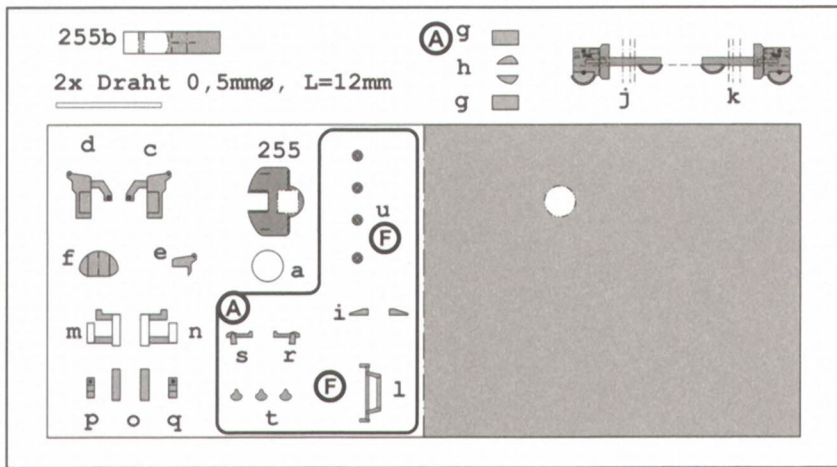
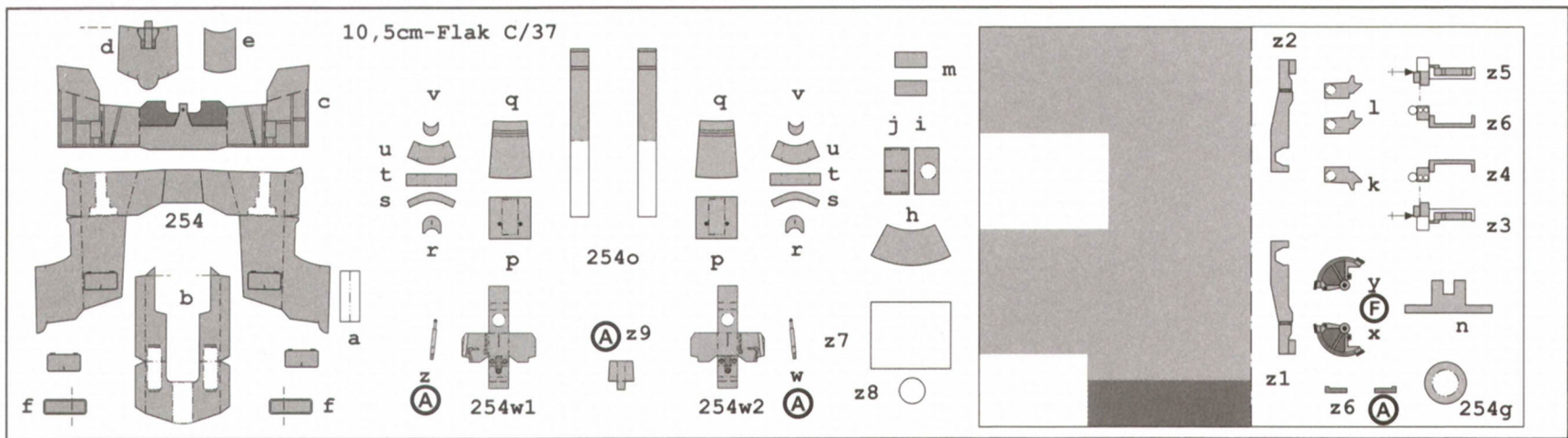

g h e f A

256

256b A A

256a f F

Draht 0,5mmø, L=12mm

A Draht 0,5mmø, L=4,5mm

c d

g h e f A

256

256b A A

256a f F

Draht 0,5mmø, L=12mm

A Draht 0,5mmø, L=4,5mm

c d

g h e f A

256

256b A A

256a f F

Draht 0,5mmø, L=12mm

A Draht 0,5mmø, L=4,5mm

c d

g h e f A

256

256b A A

256a f F

Draht 0,5mmø, L=12mm

A Draht 0,5mmø, L=4,5mm

c d

g h e f A

256

256b A A

256a f F

Draht 0,5mmø, L=12mm

A Draht 0,5mmø, L=4,5mm

c d

g h e f A

256

256b A A

256a f F

Draht 0,5mmø, L=12mm

A Draht 0,5mmø, L=4,5mm

c d

g h e f A

256

256b A A

256a f F

Draht 0,5mmø, L=12mm

A Draht 0,5mmø, L=4,5mm

c d

g h e f A

256

256b A A

256a f F

Draht 0,5mmø, L=12mm

A Draht 0,5mmø, L=4,5mm

c d

g h e f A

256

256b A A

256a f F

Draht 0,5mmø, L=12mm

A Draht 0,5mmø, L=4,5mm

c d

g h e f A

256

256b A A

256a f F

Draht 0,5mmø, L=12mm

A Draht 0,5mmø, L=4,5mm

c d

g h e f A

256

256b A A

256a f F

Draht 0,5mmø, L=12mm

A Draht 0,5mmø, L=4,5mm

c d

g h e f A

256

256b A A

256a f F

Draht 0,5mmø, L=12mm

A Draht 0,5mmø, L=4,5mm

c d

2 cm Vierlingsflak

257a

257d

257i

q F

f e

h g

Draht 0,5mmø, L=9,5mm

2 cm Vierlingsflak

257a

257d

257i

q F

f e

h g

Draht 0,5mmø, L=9,5mm

257

c A

p n

b m

l k j r

257

c A

p n

b m

l k j r

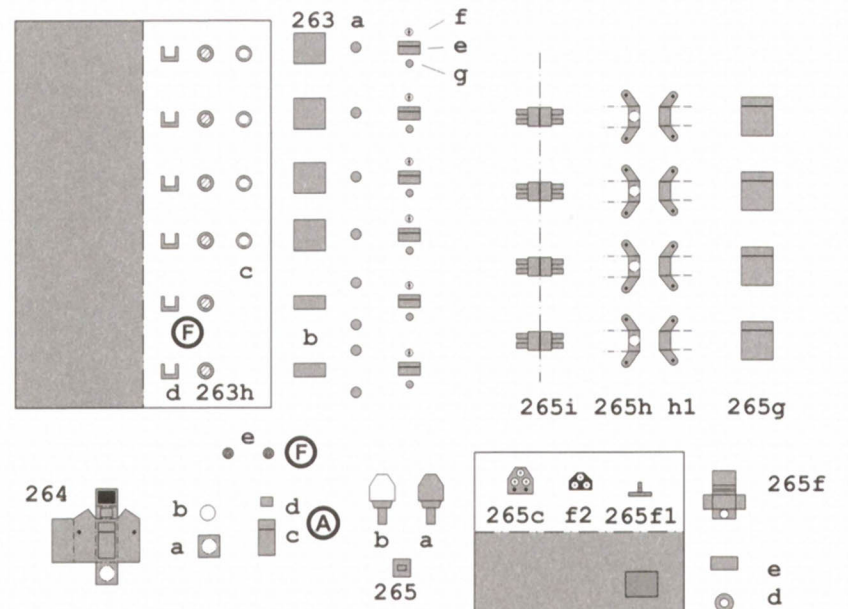
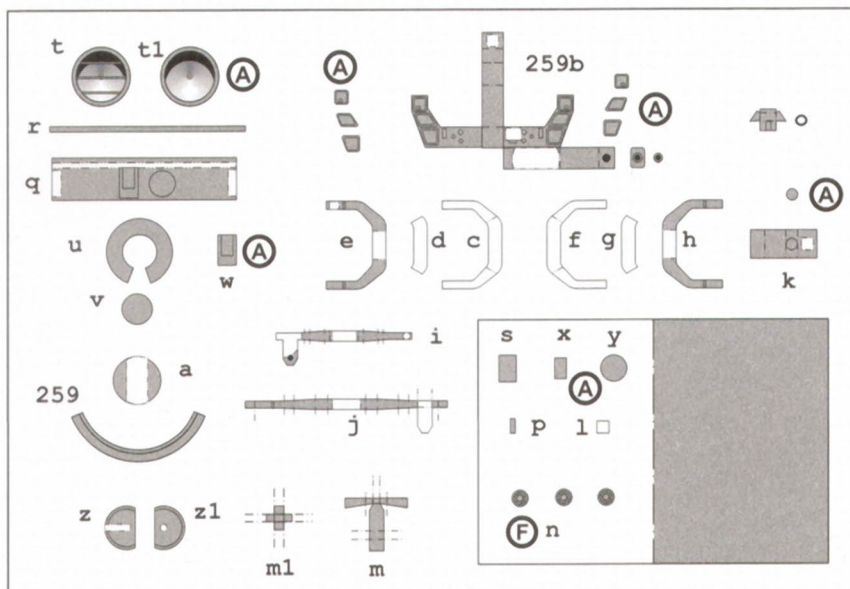
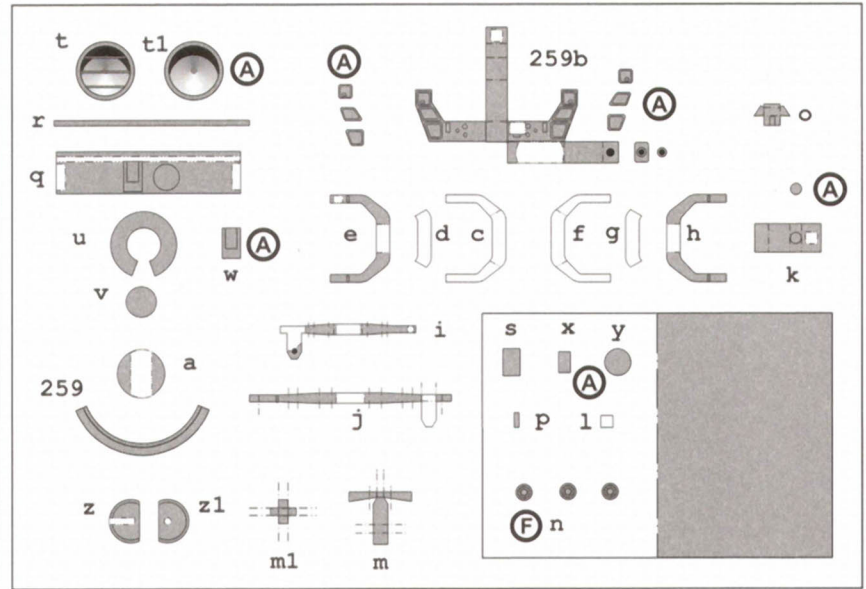
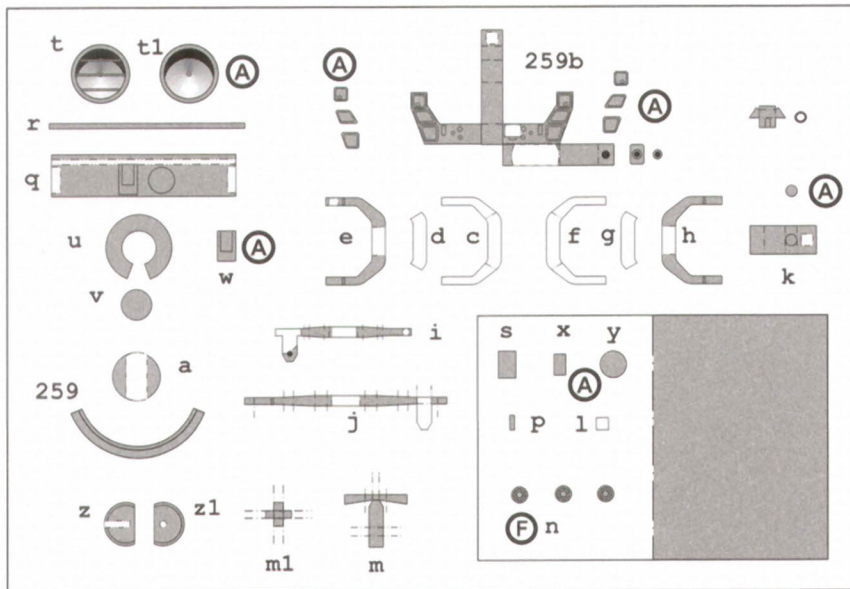
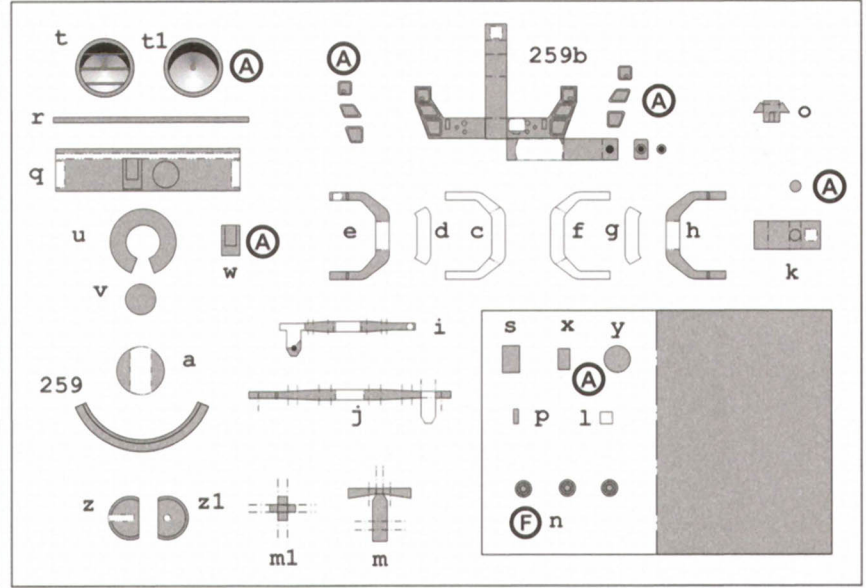
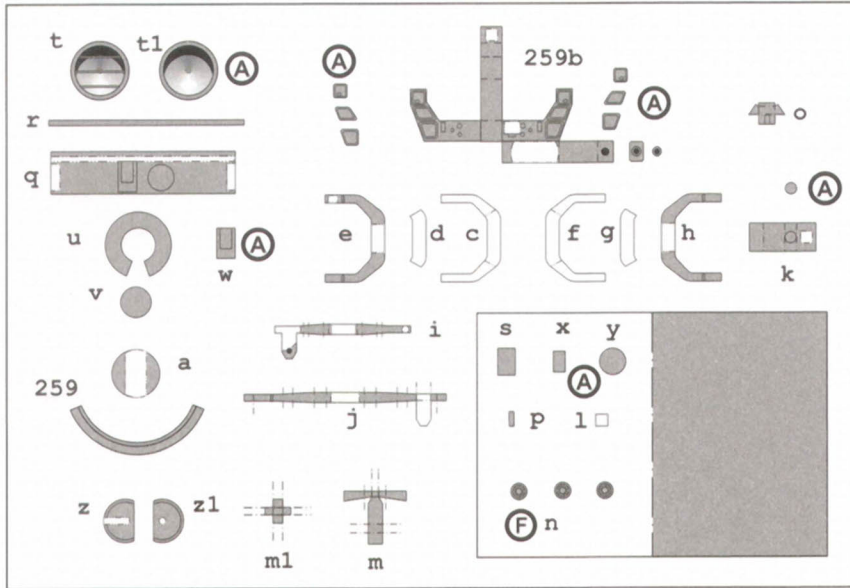
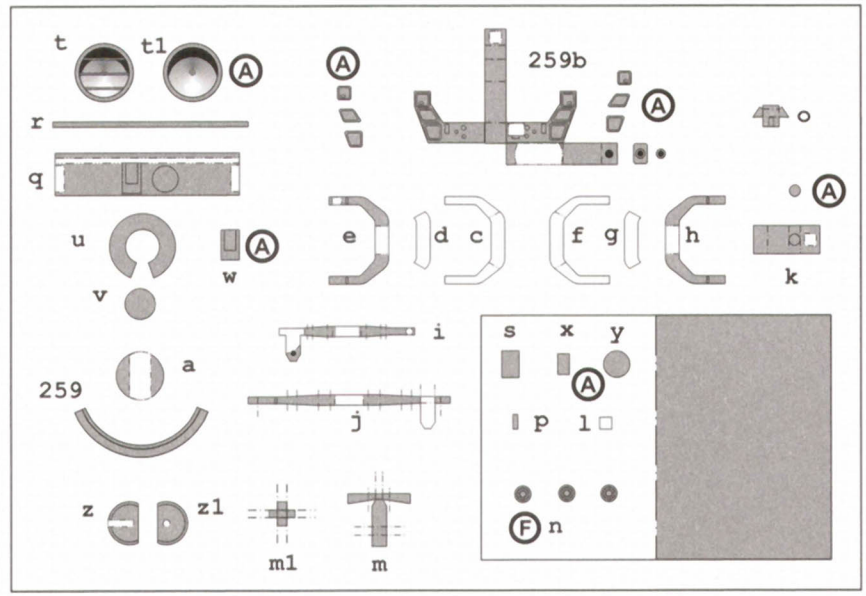
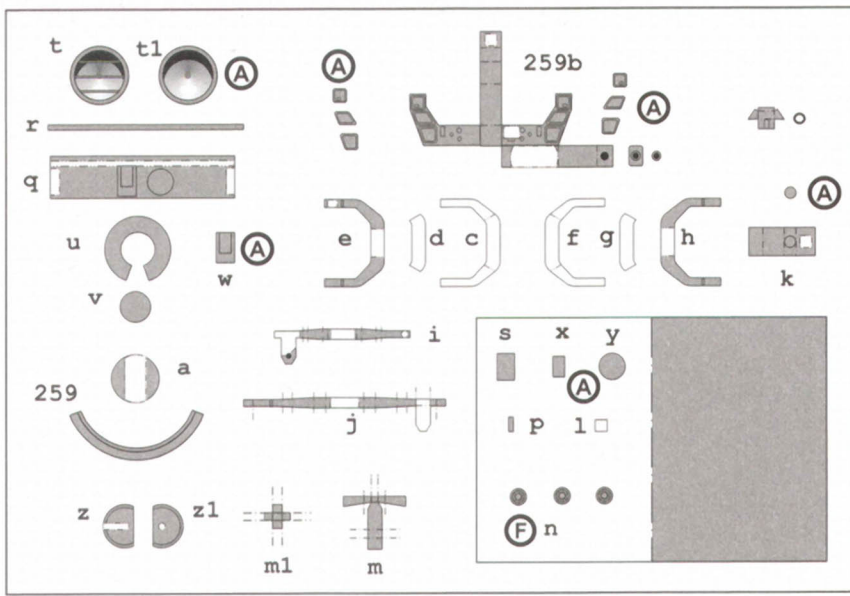

3m-Nacht-E-Messgerät

Draht 4mm x 0,5ø
Draht 3,5mm x 0,7ø

3m-Nacht-E-Messgerät

Draht 4mm x 0,5ø
Draht 3,5mm x 0,7ø

Scheinwerfer-Richtsäule

Artillerie-Richtsäule

Draht 0,5ø

271n 271l 271m

Scheinwerfer-Richtsäule

Artillerie-Richtsäule

Draht 0,5ø

271k 271j

Scheinwerfer-Richtsäule

Artillerie-Richtsäule

Draht 0,5ø

Motorbarkasse (Reserve)

Scheinwerfer-Richtsäule

Artillerie-Richtsäule

Draht 0,5ø

Richtsäule

Scheinwerfer-Richtsäule

Scheinwerfer-Richtsäule

Richtsäule

Scheinwerfer-Richtsäule

Scheinwerfer-Richtsäule

Richtsäule

Richtsäule

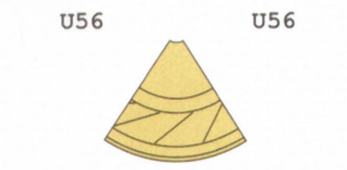
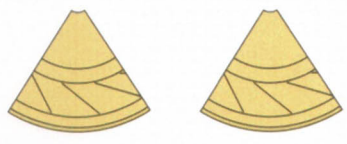
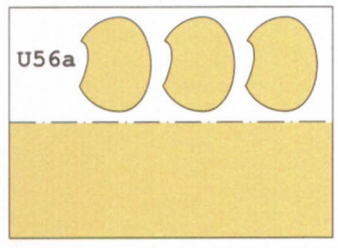
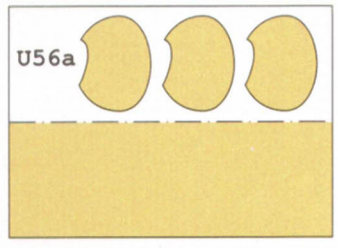
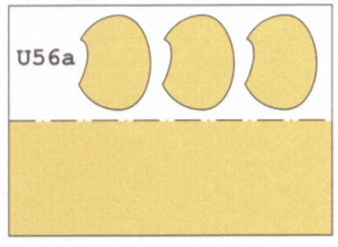
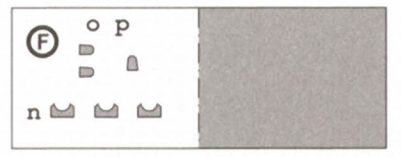
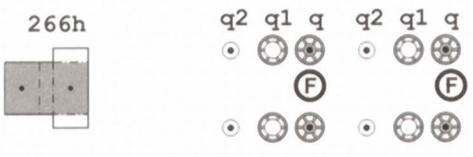
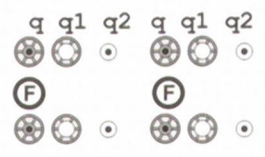
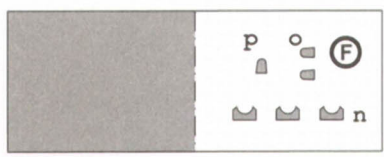
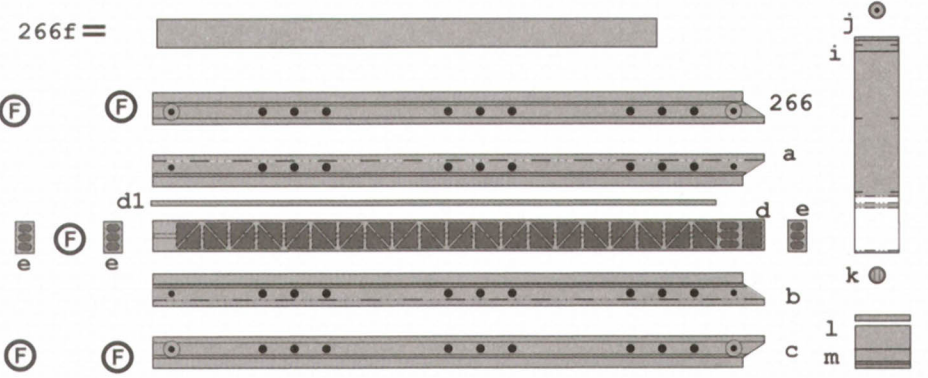
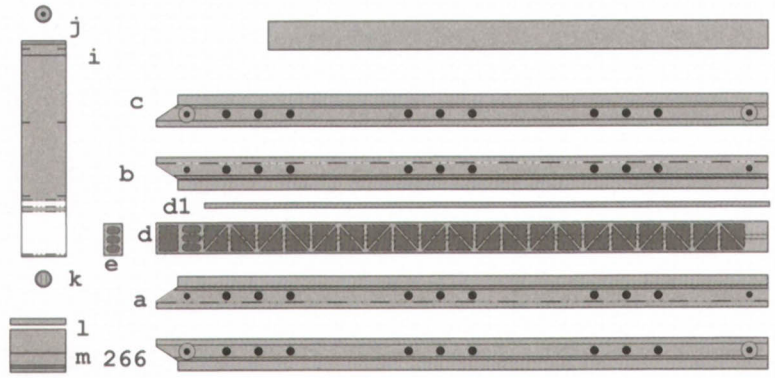
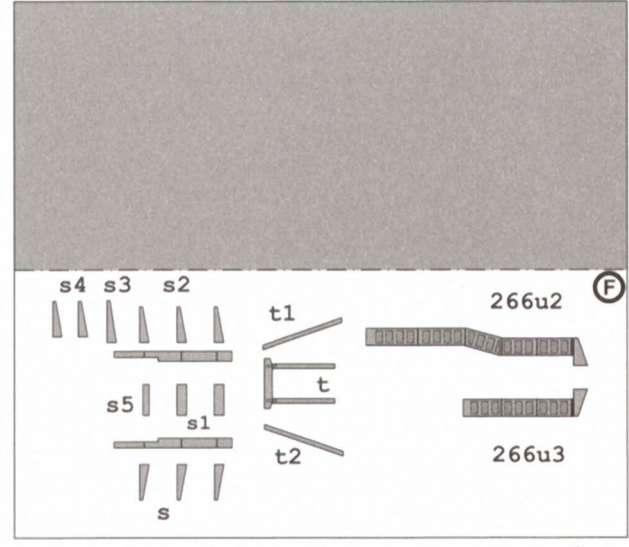
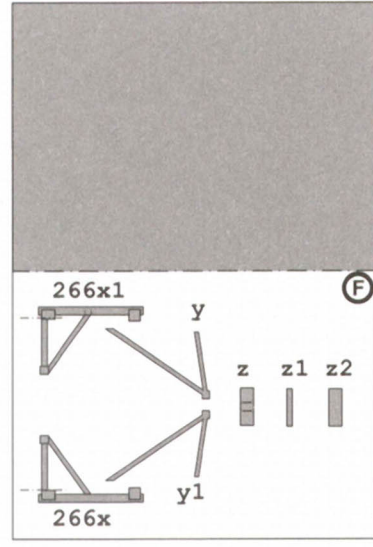
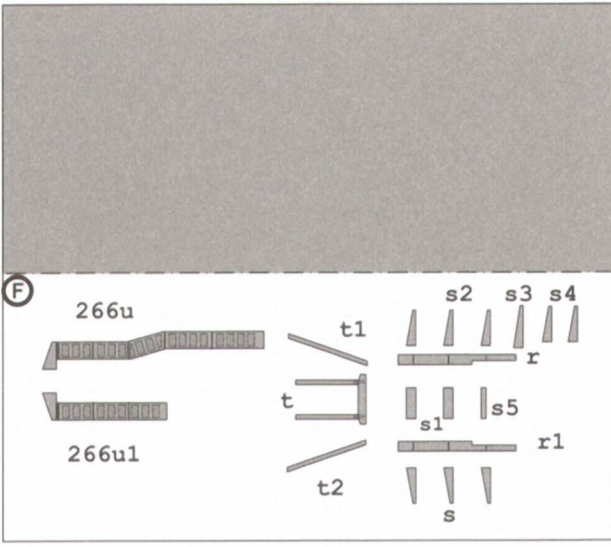
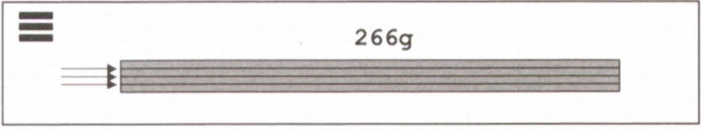
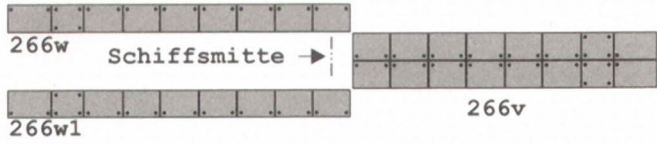

U56 Steuerbord-Schraube starbord-propeller

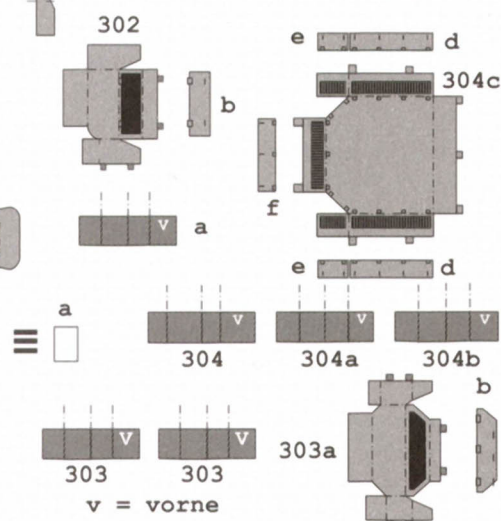
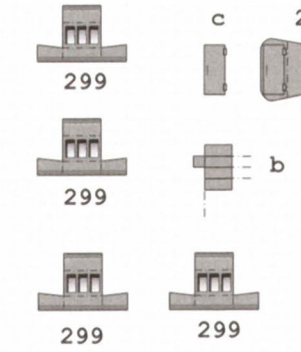
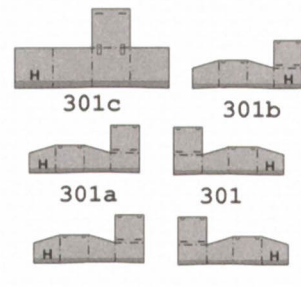
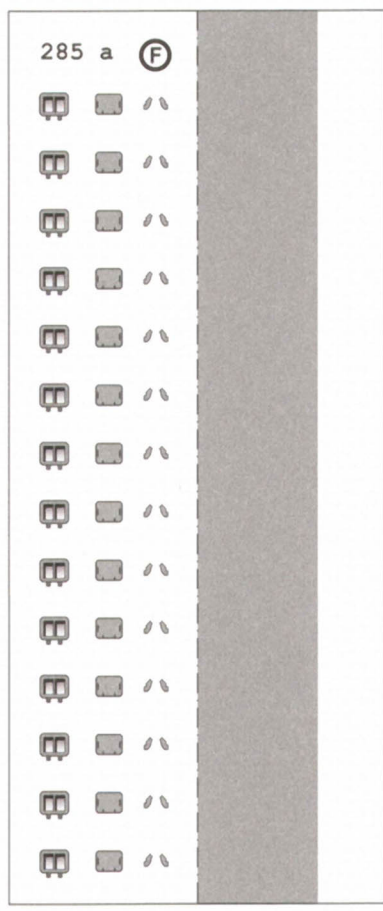
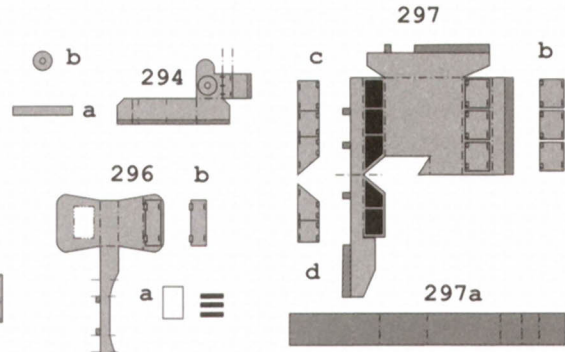
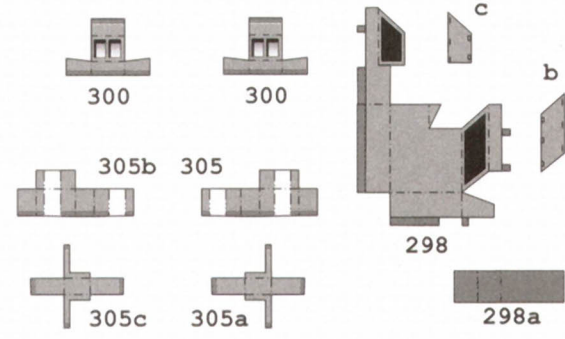
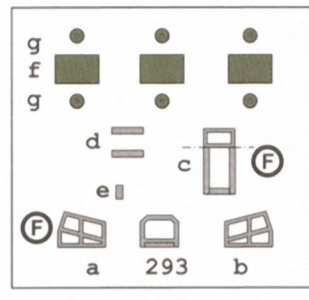
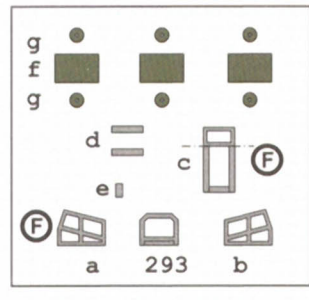
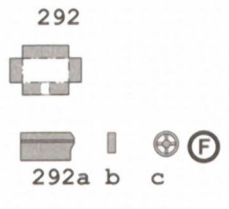

v = vorne

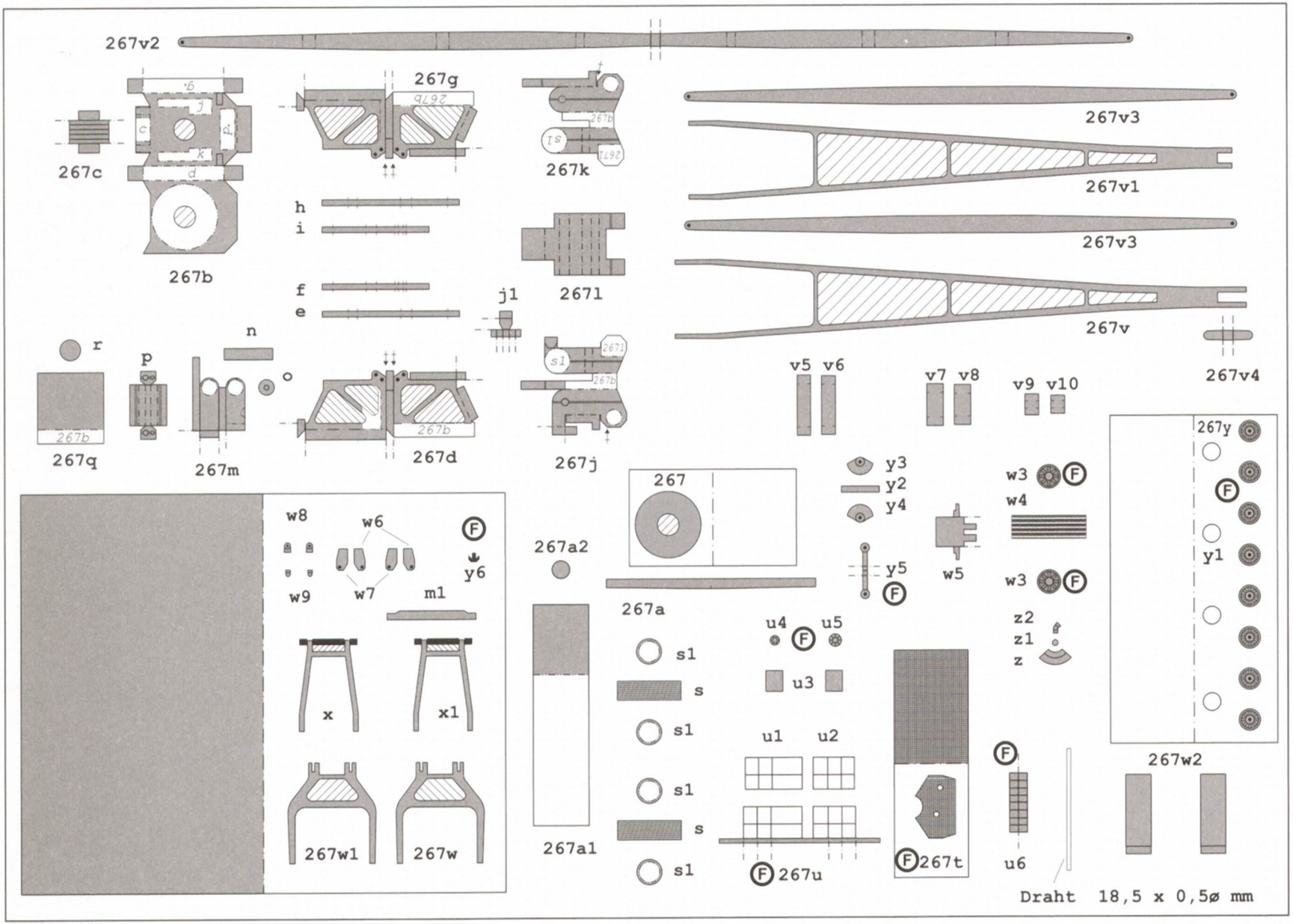
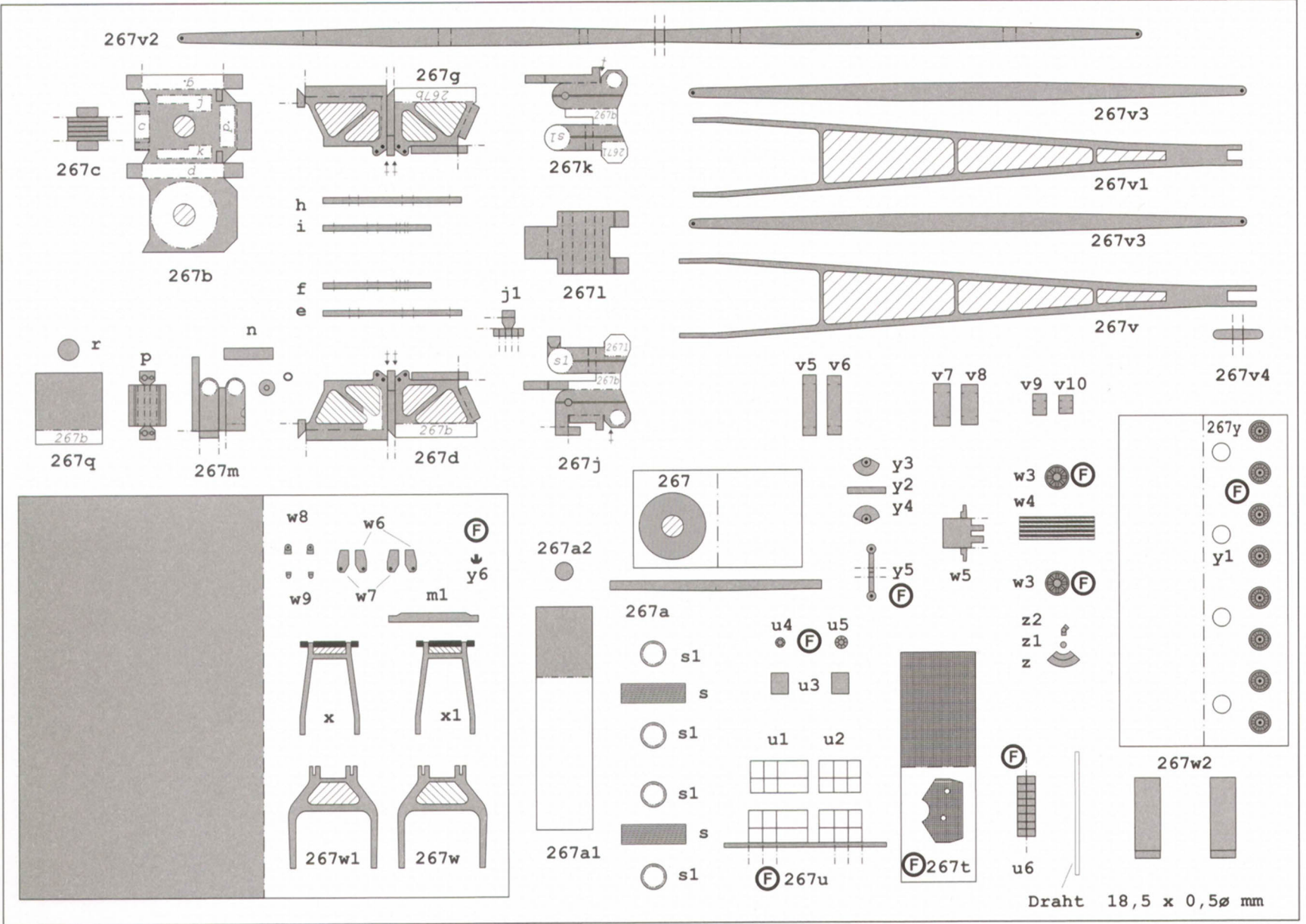

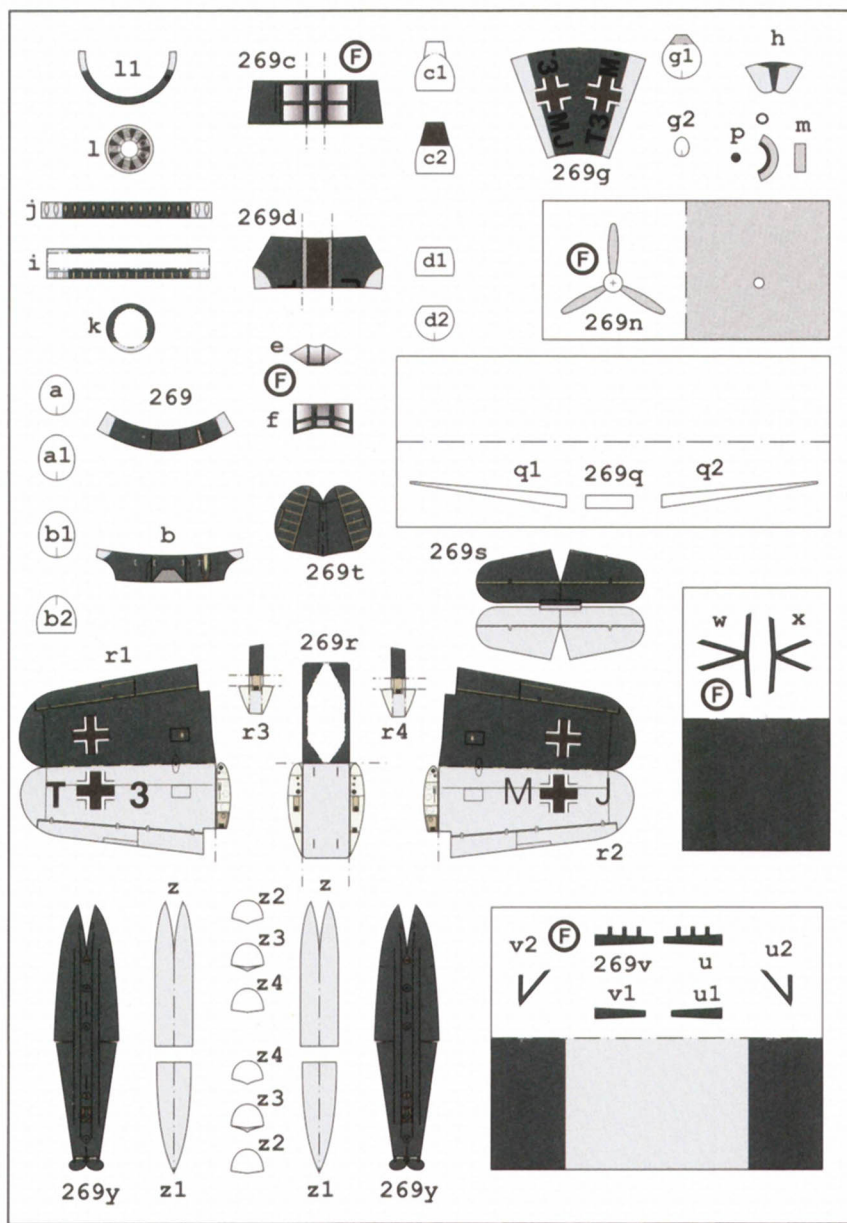
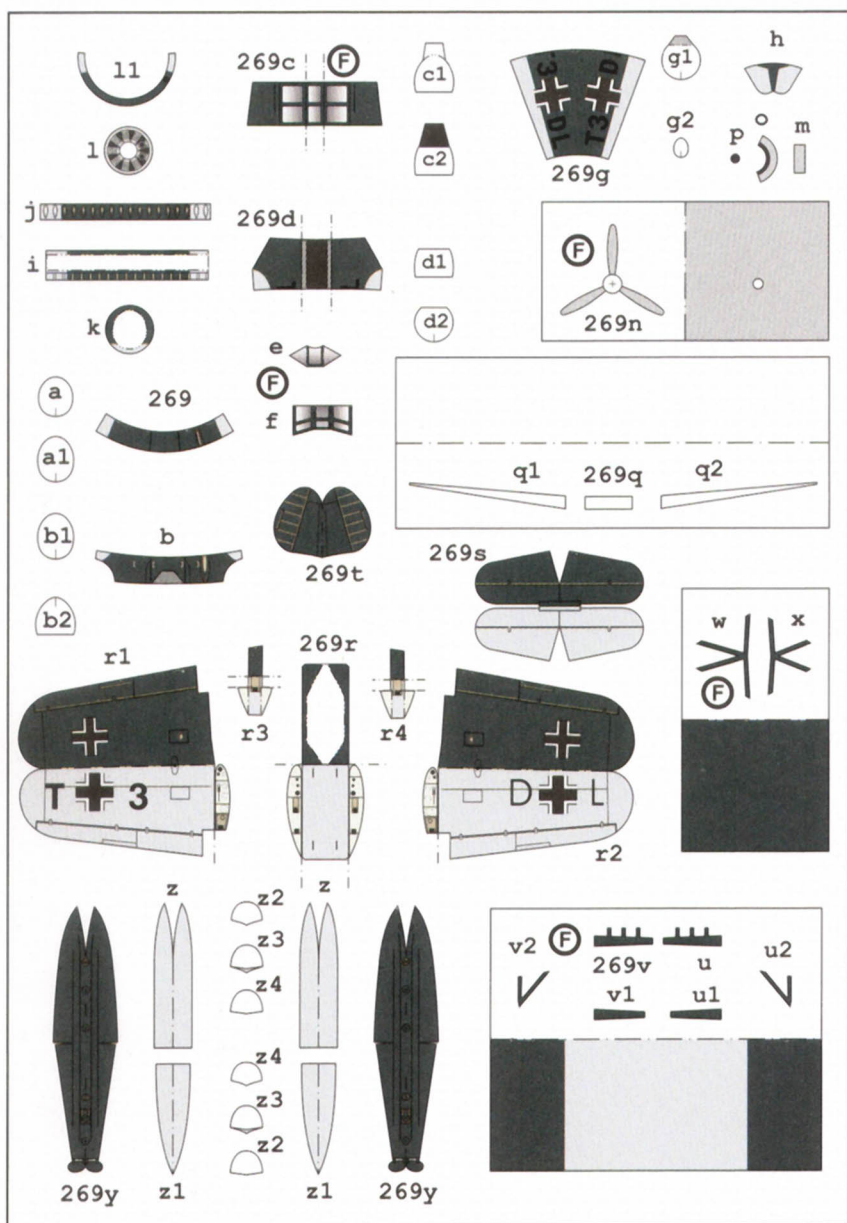
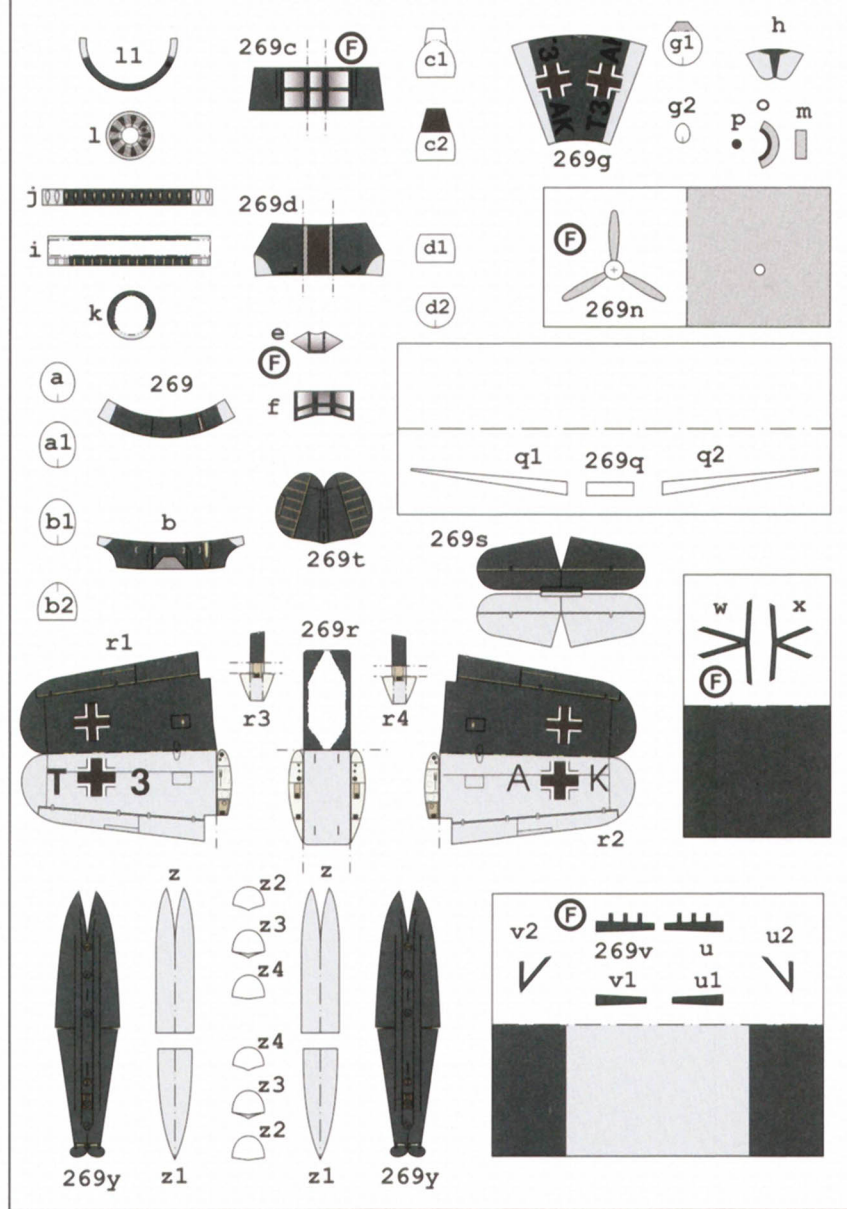
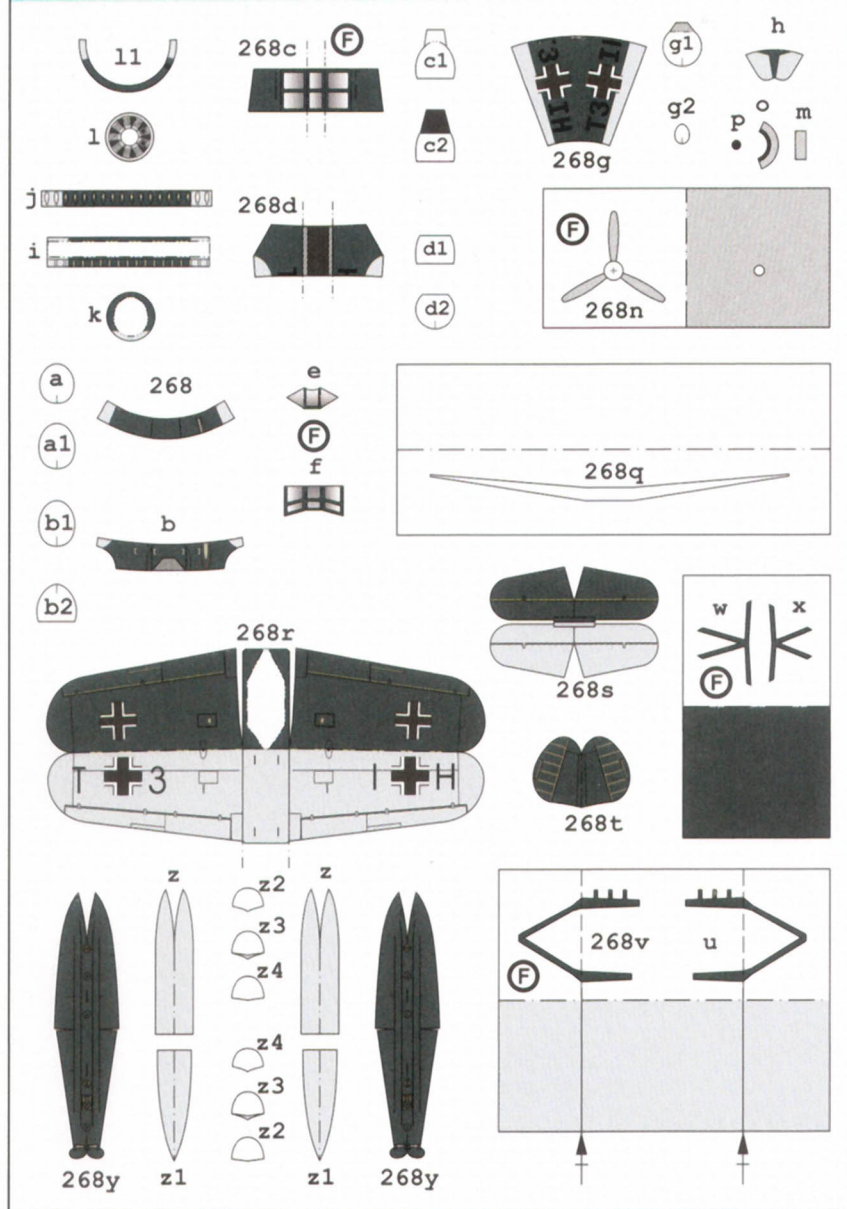

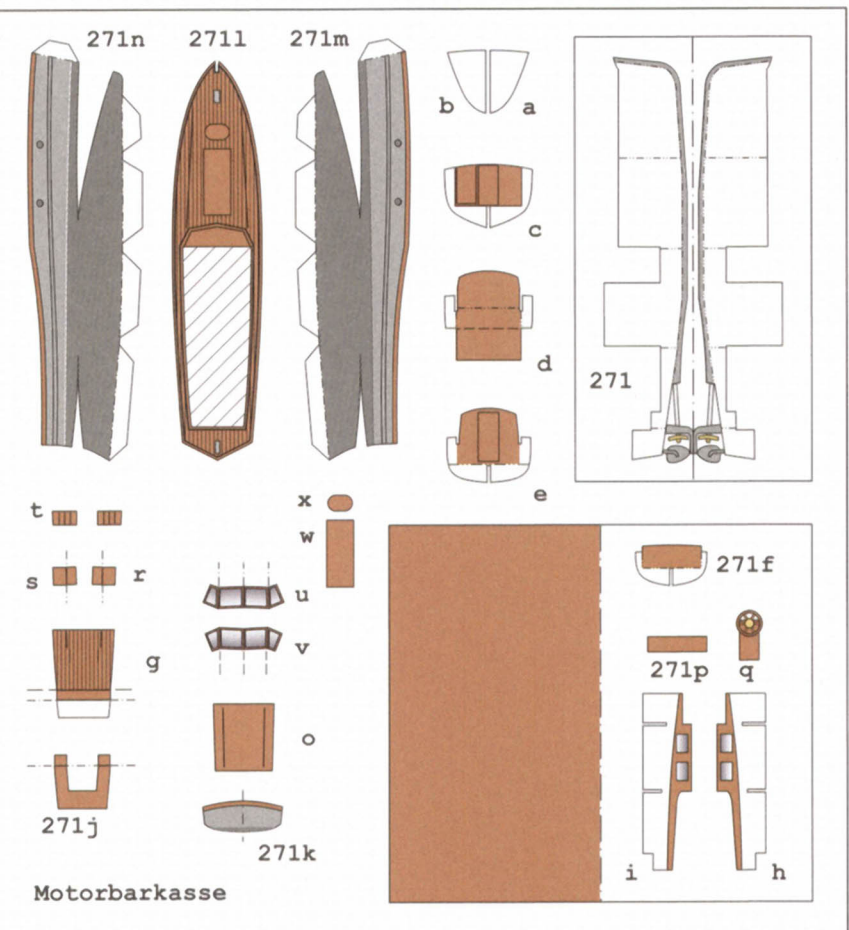
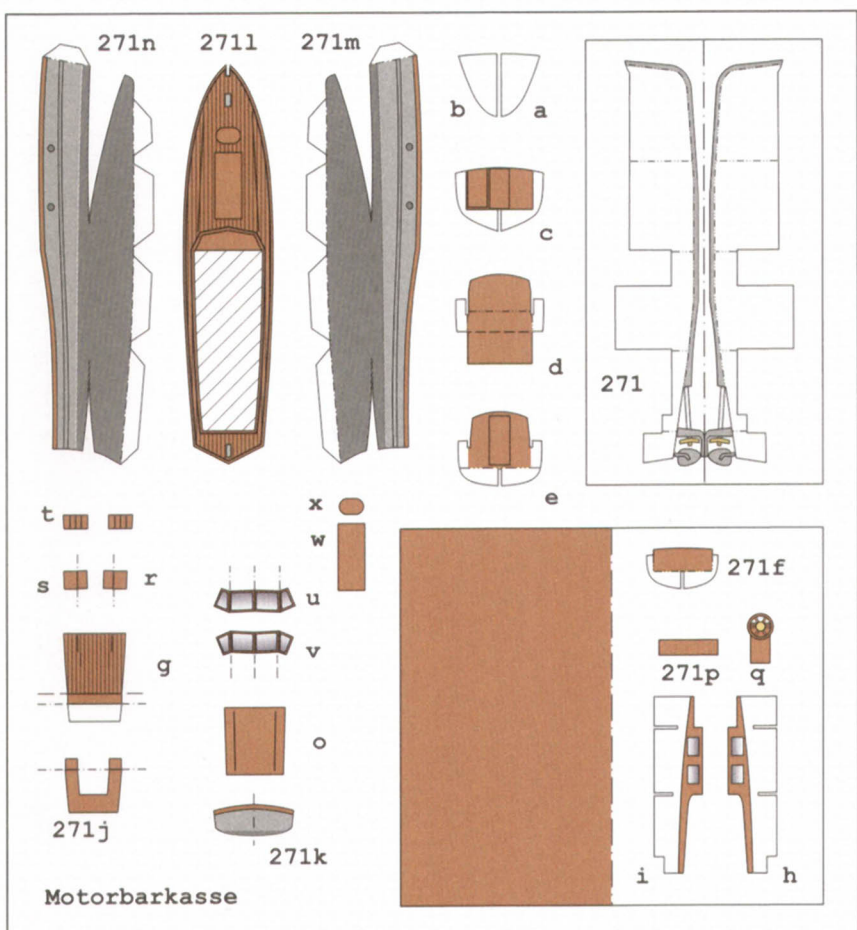
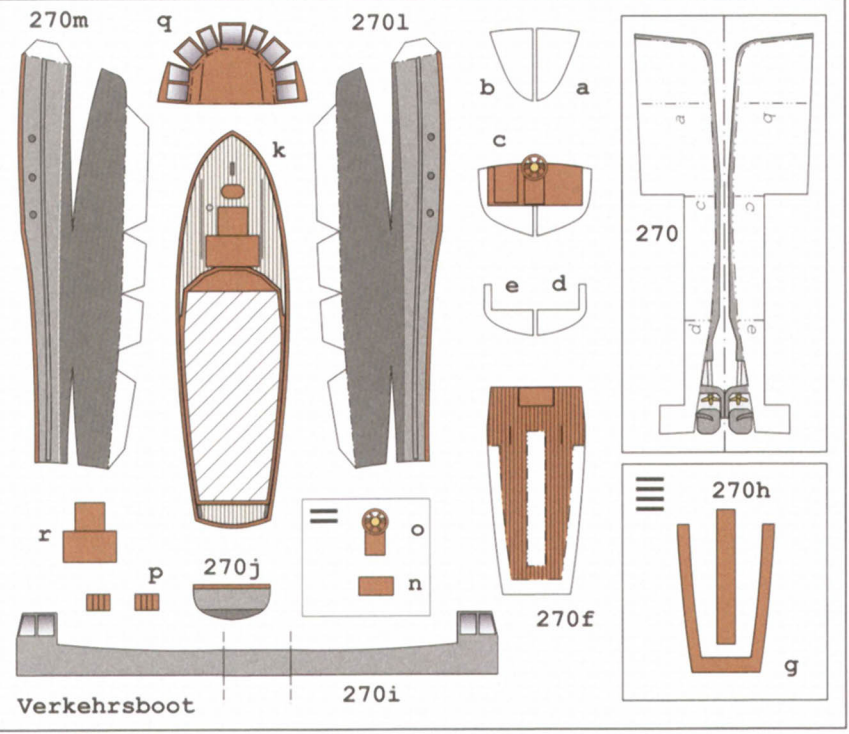
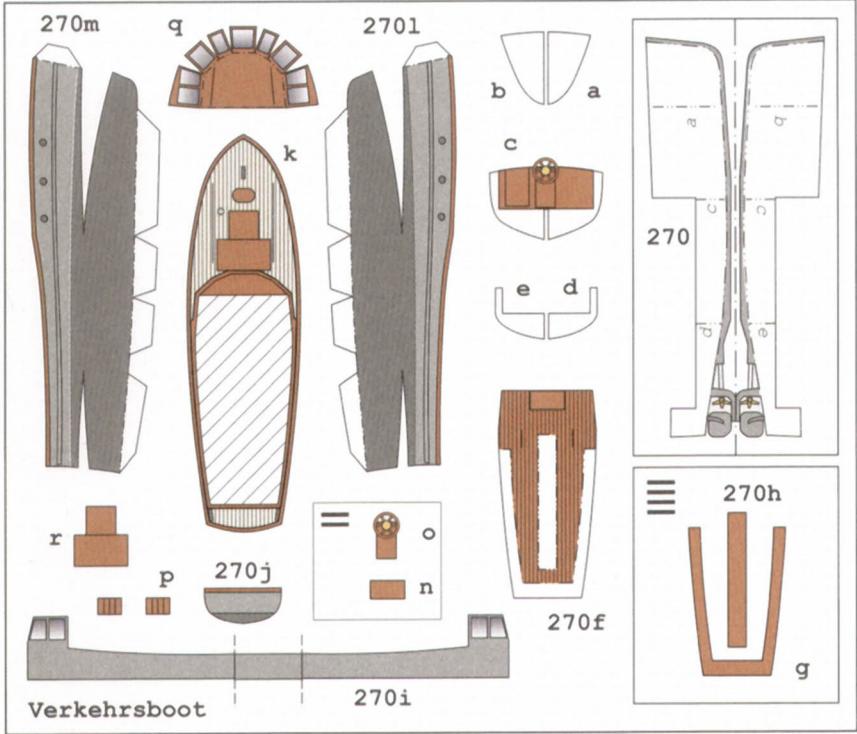
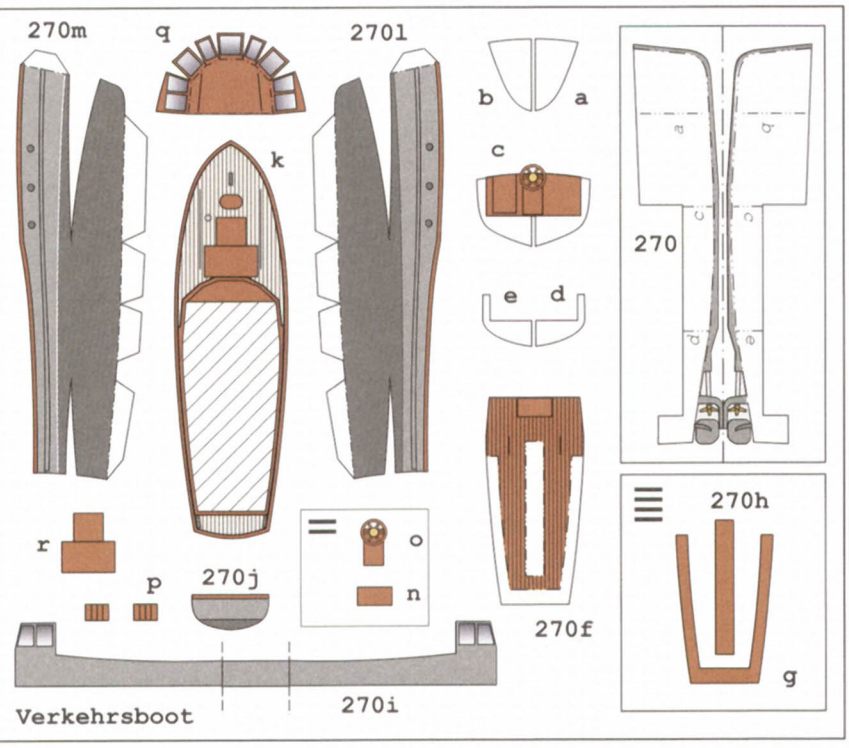
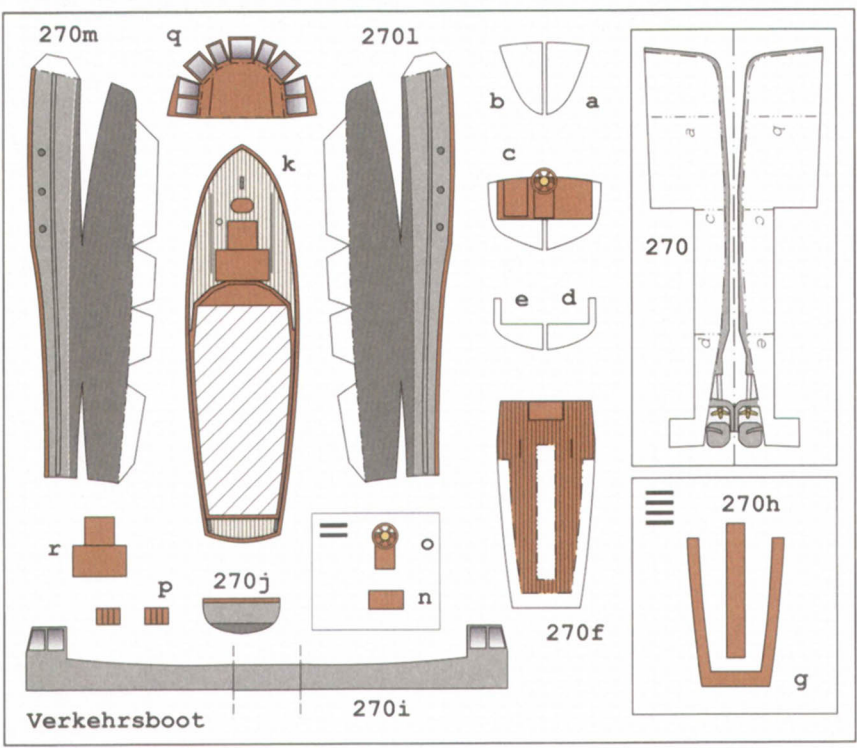

Motorbarkasse

272s 272k
272r 272g
272h
272d 272b
272c 272q
272e 272f
272o 272n 272p
272a 272i 272j
272t 272m

272

Jolle

273c 273e g 273 f a
273i j
273b h

Jolle

273c 273e g 273 f a
273i j
273b h

Jolle

273c 273e g 273 f a
273i j
273b h

Jolle

273c 273e g 273 f a
273i j
273b h

Bereitschaftskutter

276c 276e g 276 f a
276i j
276b h

Bereitschaftskutter

276c 276e g 276 f a
276i j
276b h

Dingi

274c 274d f 274 e b
274h i
274h1 274h2

Dingi

274c 274d f 274 e b
274h i
274h1 274h2

Dingi

274c 274d f 274 e b
274h i
274h1 274h2

Dingi

274c 274d f 274 e b
274h i
274h1 274h2

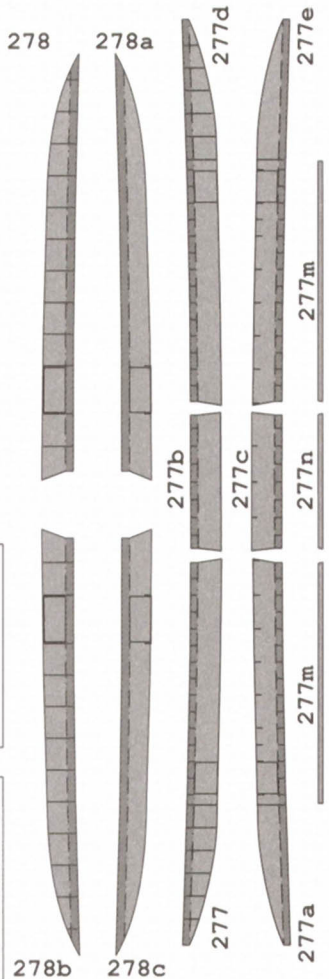
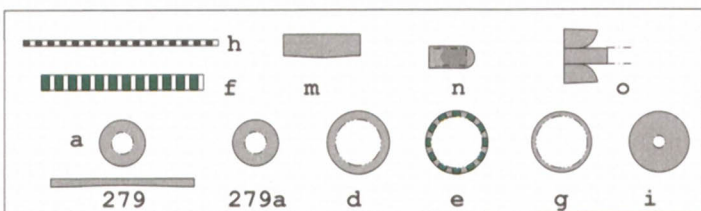
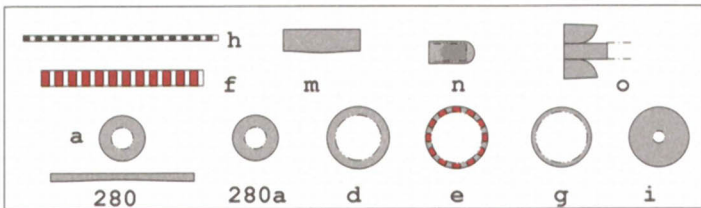
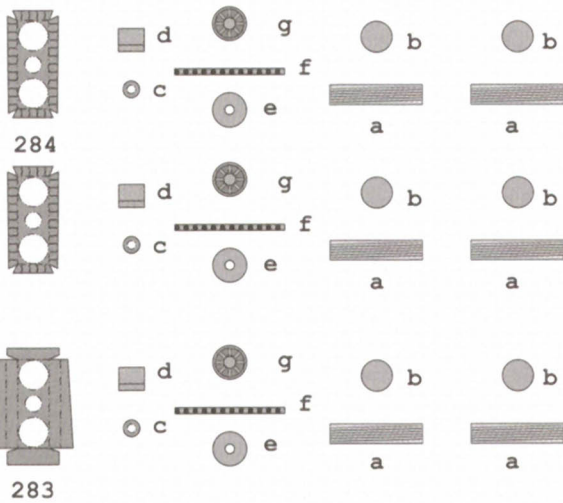
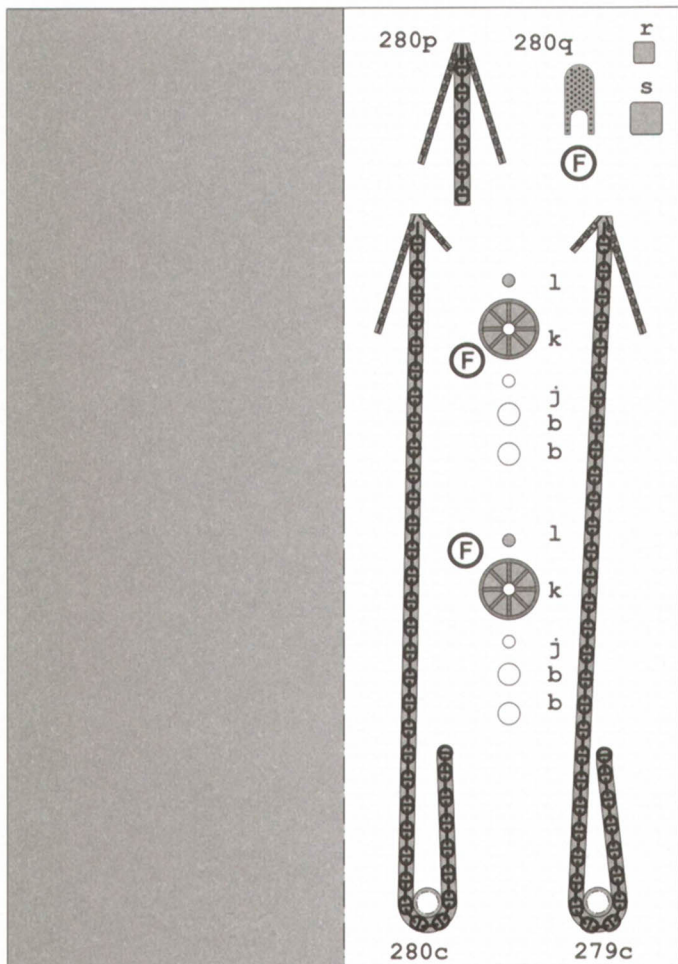
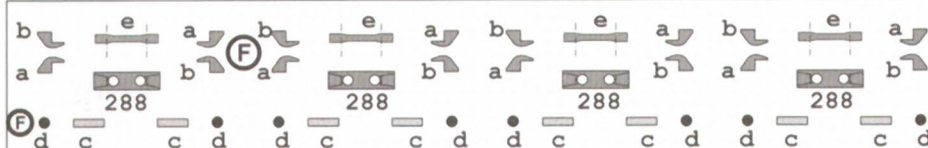
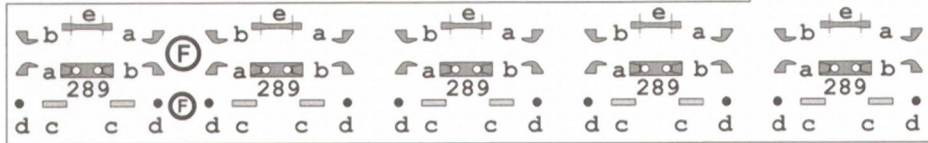
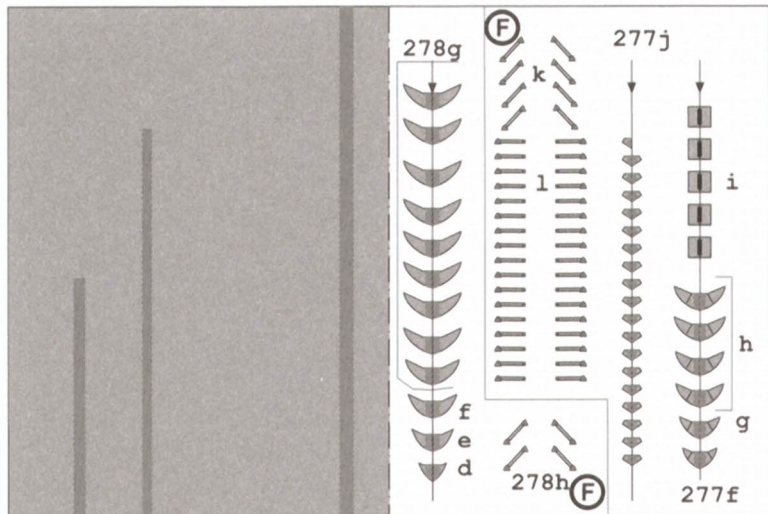
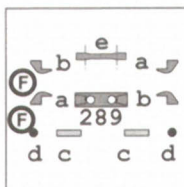
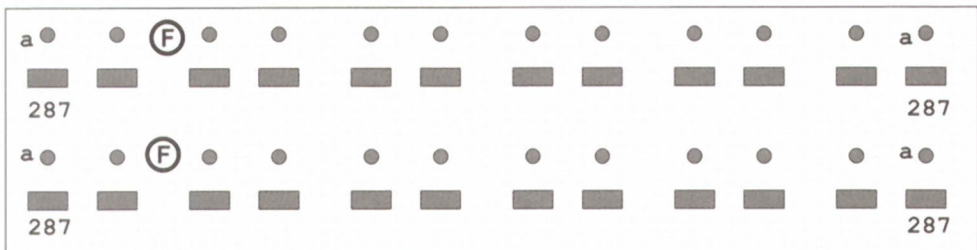
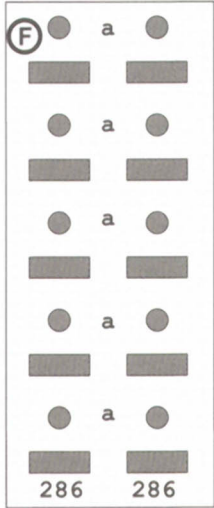
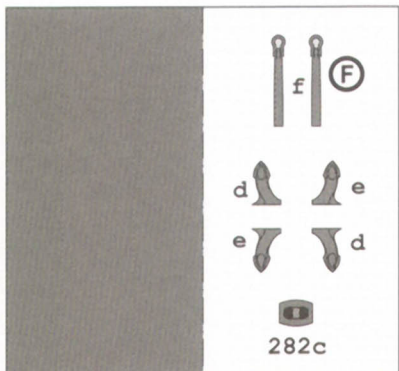
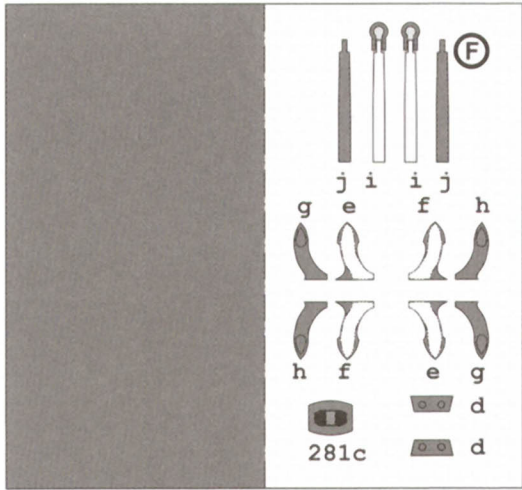
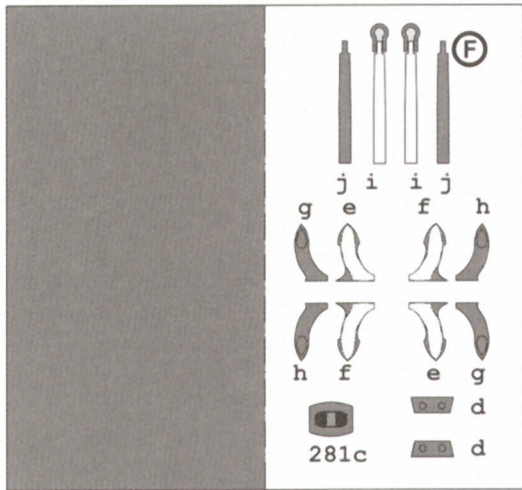
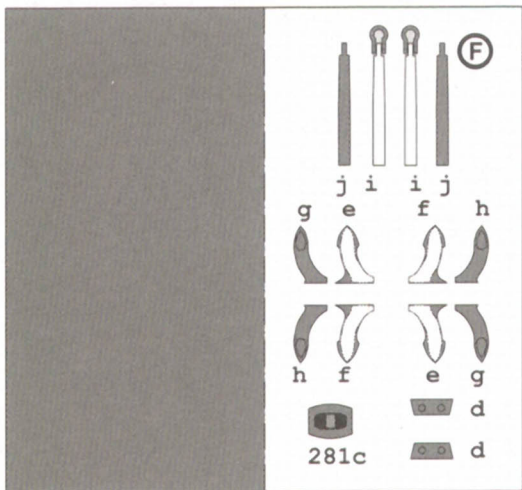

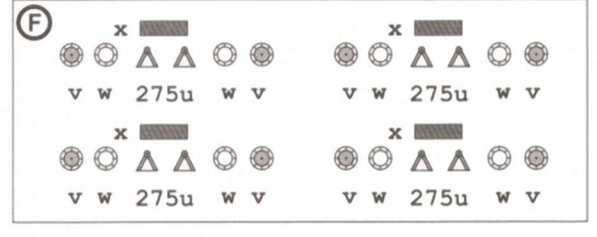
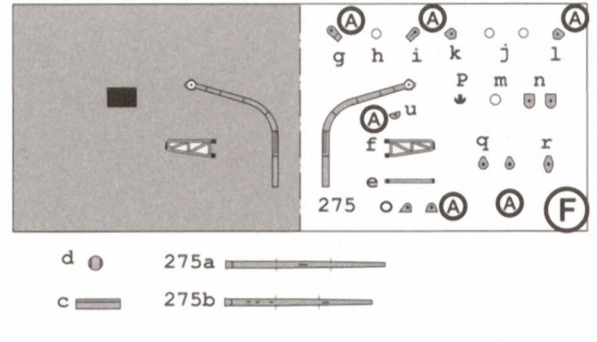
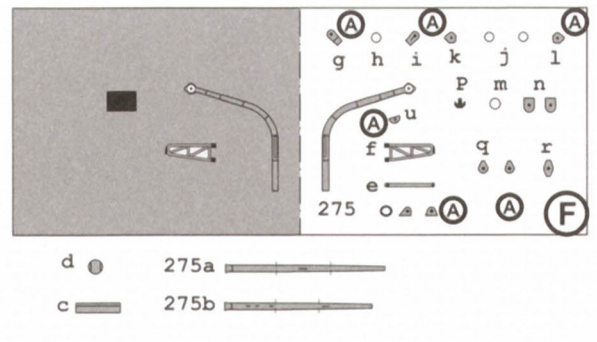
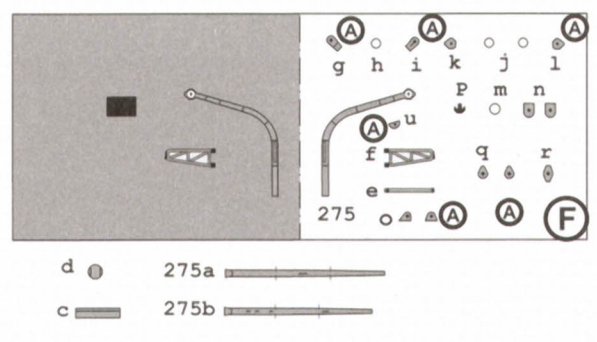
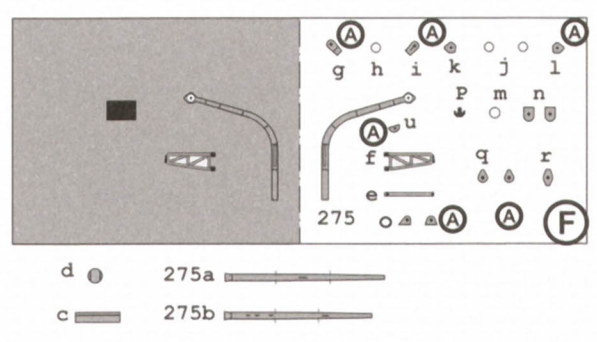
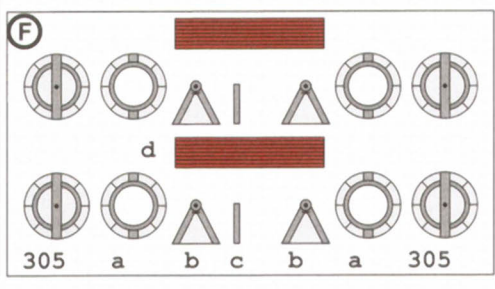
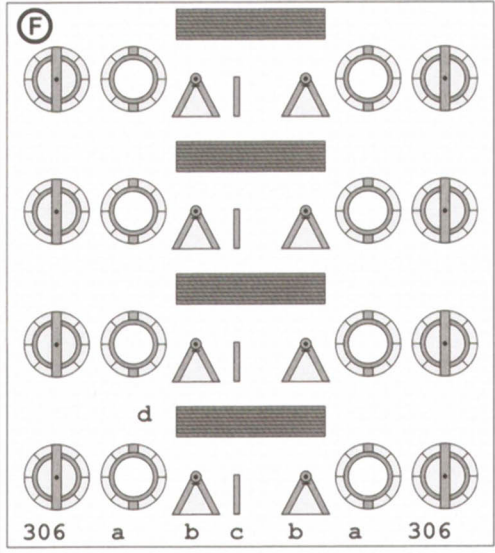
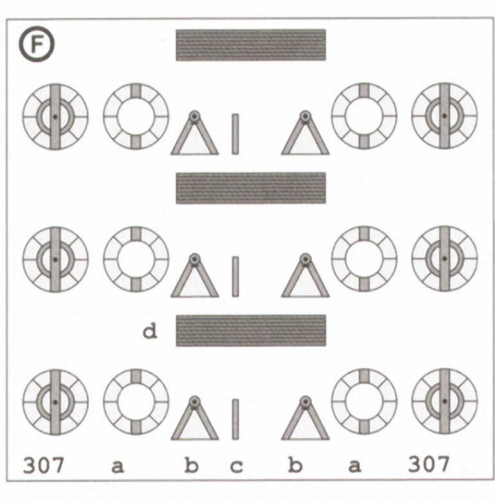
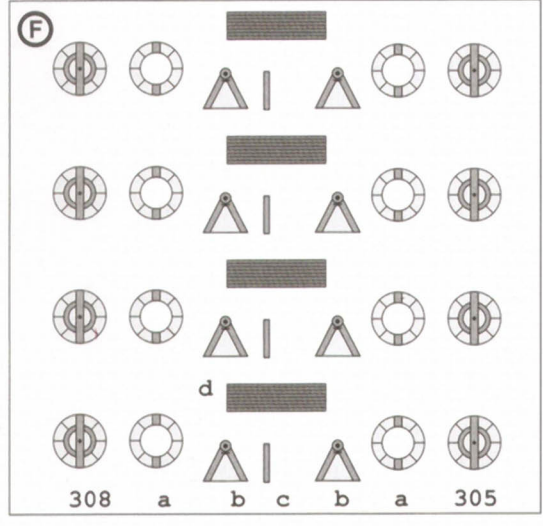
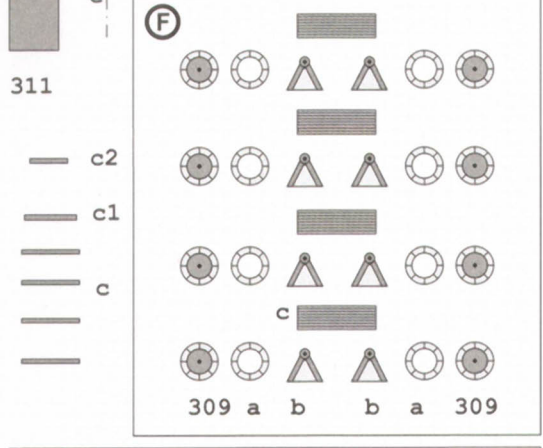
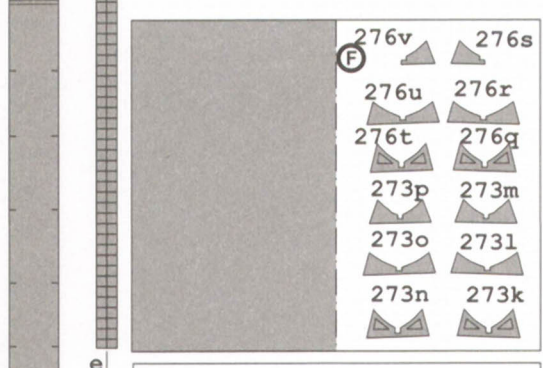
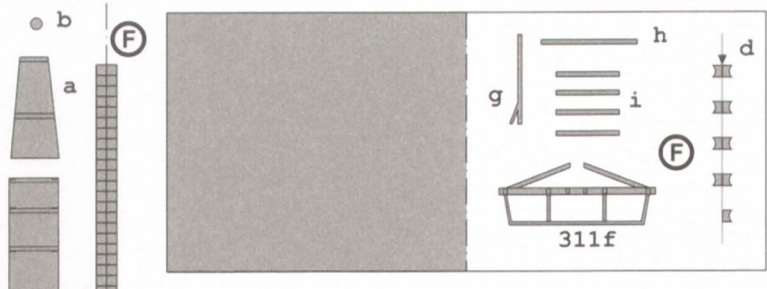
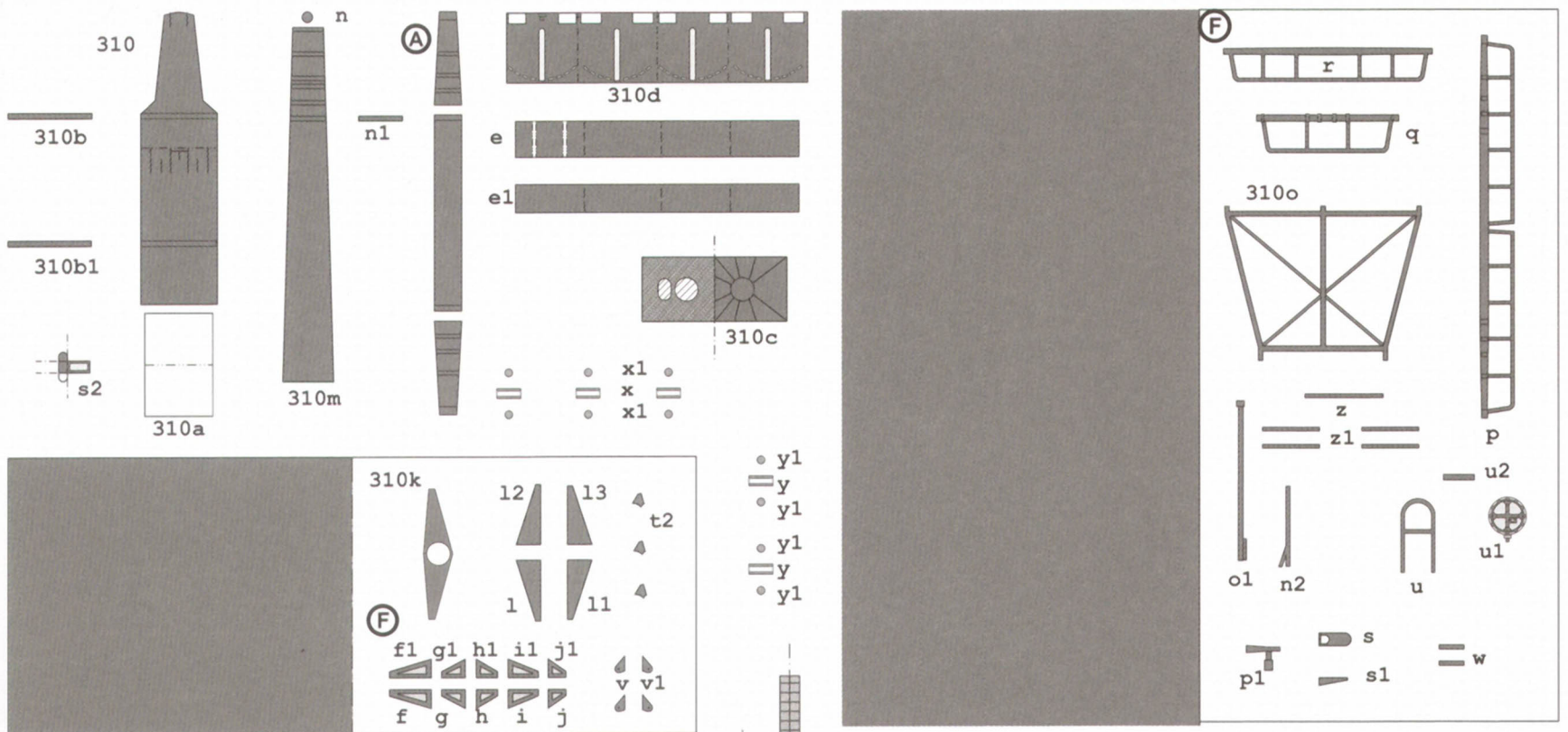

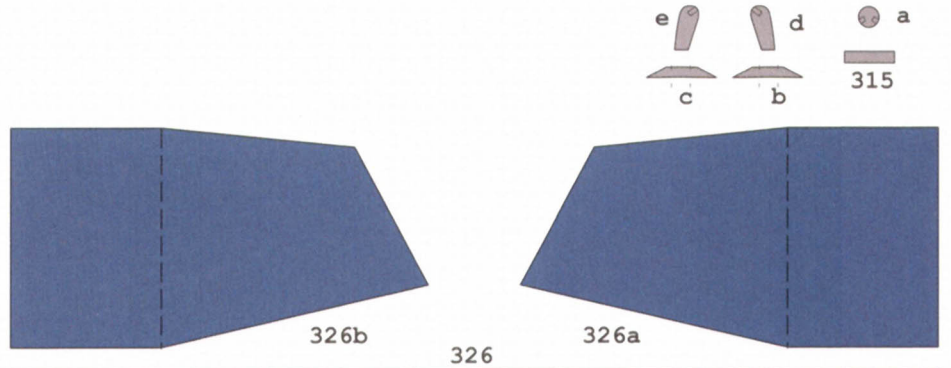
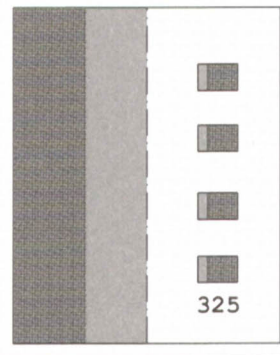
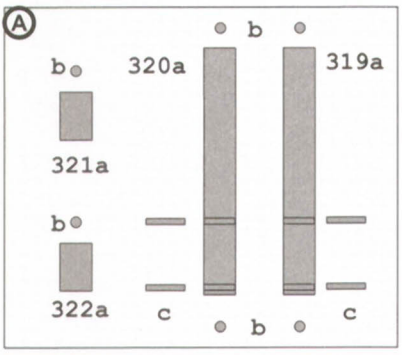
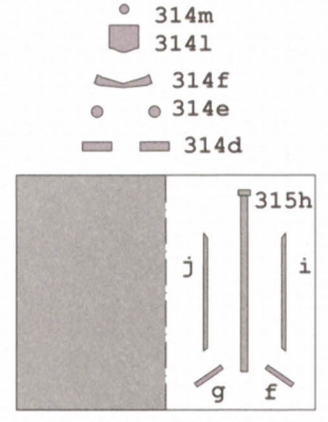
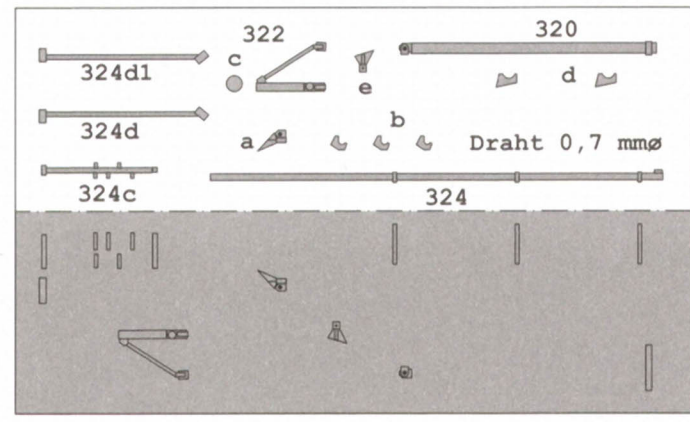
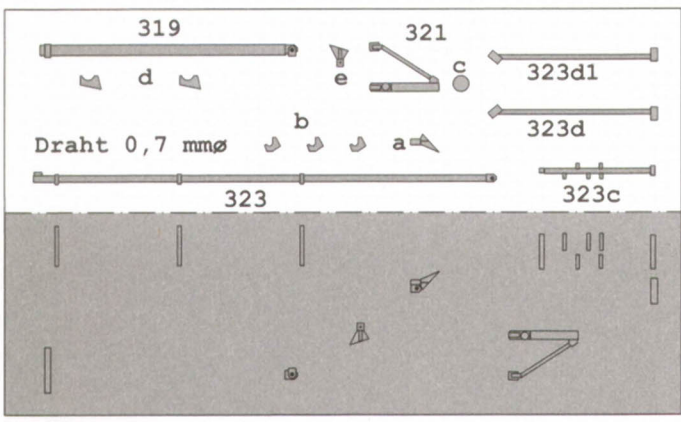
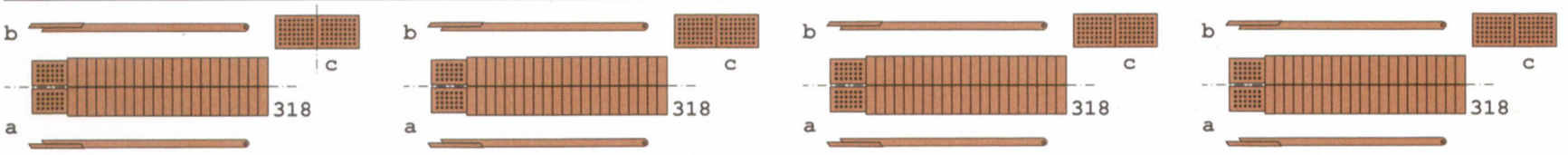
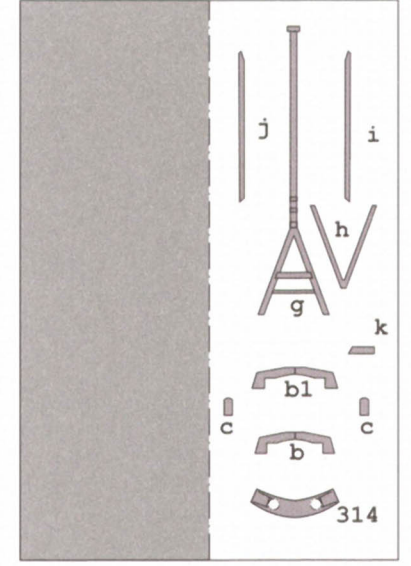
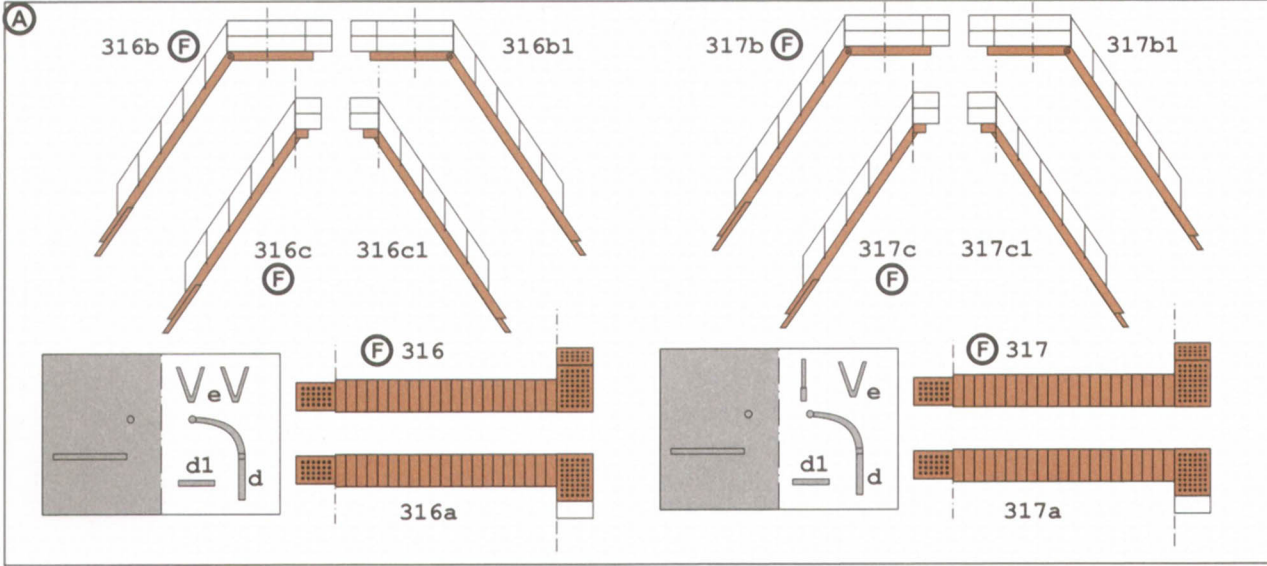
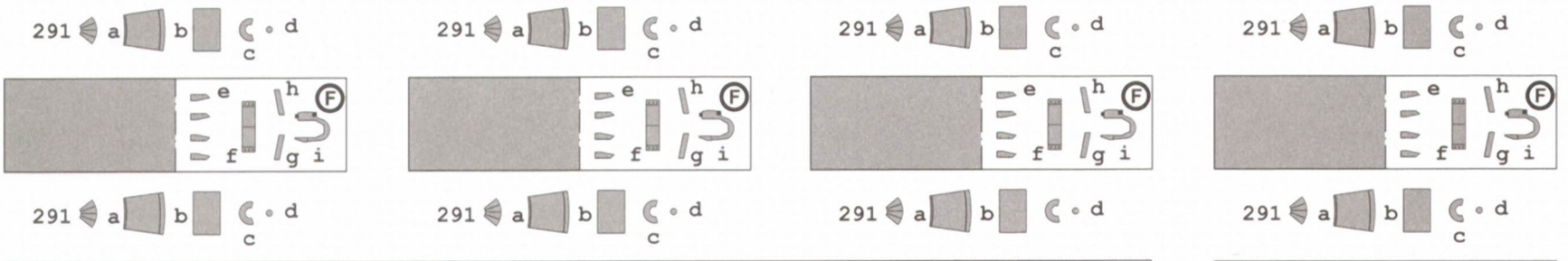
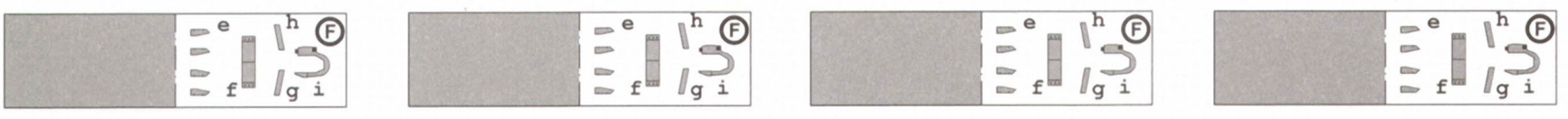
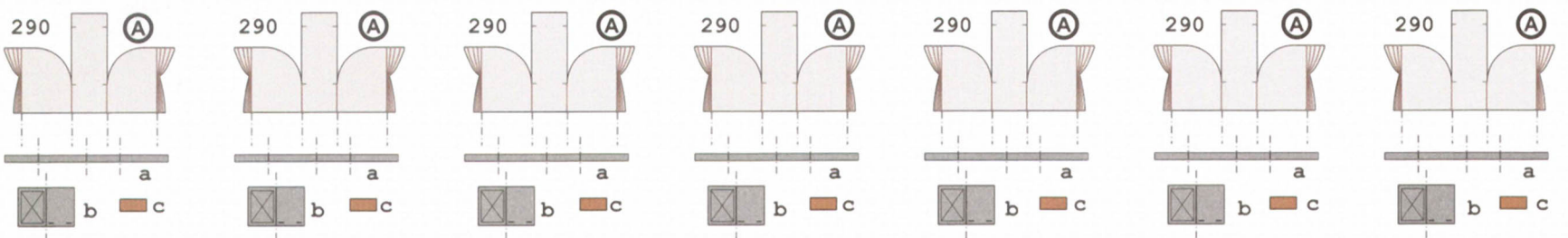

Schlachtschiff Bismarck

BAUANLEITUNG

Schlachtschiff » Bismarck «

Allgemeines zum Bau von Kartonmodellbaugosen:

Zum Bau eines Modellbaugosen werden nur wenige Werkzeuge benötigt: eine Schere, ein Bastelmesser, ein Metalllineal, eine gute Pinzette und handelsüblicher Alleskleber. Wer mag, kann weitere nützliche Hilfsmittel wie Zahnstocher, Rundhölzer verschiedener Durchmesser und eine Stopfnadel verwenden. Farbstifte zum Einfärben von Schnittkanten sind ebenfalls sinnvoll. Alle Teile werden auf der Linie ausgeschnitten. Das Modell sollte in der von der Bauanleitung vorgegebenen Reihenfolge zusammengebaut werden. Damit nichts verloren geht, jeweils nur die gerade benötigten Bauteile ausschneiden. Komplizierte Teile vor der endgültigen Montage sorgfältig anpassen. Dünne hohle Bauteile (z. B. Masten) können mit Draht versteift werden, um eine höhere Stabilität zu erzielen. Einige Bauteile werden ggf. durch Verdoppeln oder Verdreifachen auf Abfallkarton verstärkt. Das Spantengerüst sollte auf einer möglichst ebenen Unterlage (z. B. einer Glasplatte) montiert und vorsichtig beschwert werden, um Verzug während der Aushärtezeit zu vermeiden. Nach Montage der Decks und der Außenhaut das Modell ebenfalls vorsichtig beschweren. Dem Klebstoff immer genug Zeit zum Aushärten lassen. Und nun viel Spaß beim Bau Ihrer Bismarck!

Liniencode:

- · - · - · - · - · - ·	Auf der bedruckten Seite rillen und nach hinten knicken.	
- - - - - - - - - - -	Auf der Rückseite rillen und nach vorn knicken, dazu ggf. mit einer Nadel die Eckpunkte durchstechen.	
- · - · - · - · - · - ·	Begrenzungslinie für aufzuklebende Bauteile. Die kursivgeschriebene Nummer gibt das anzuklebende Teil an.	
→	einschneiden	
Ⓐ	alternatives Bauteil	
Ⓕ	Kann durch ein Fotoätzteil ersetzt werden (in extra erhältlichem Super Detail Set enthalten).	
≡	Mit Abfallkarton verdoppeln.	≡≡≡ Mit Abfallkarton verdreifachen.

Bb = Backbord (links), Stb = Steuerbord (rechts) V = vorn H = hinten

General Cardmodeling Construction Principles

Building paper models requires only a few necessary tools: a pair of scissors, a hobby knife, a metal ruler, a pair of tweezers and a good glue. If desired one can also use aids such as toothpicks and dowels of different sizes. Felt pens are good for colouring the cut edges of the parts. All parts are to be cut out right on the lines. The model is built in numerical order following the instructions and checking the title picture. To keep from losing or mixing up parts only cut them out as they are needed. Dry fit complicated parts before gluing. Thin hollow parts such as masts can be stiffened with wire, round toothpicks or small dowels. Some parts are doubled by first gluing the rough-cut parts on scraps of the same card and then cutting out exactly. The frame must be built on a perfectly even surface to prevent warping. After mounting the decks and hull sides carefully weight the model down while the glue sets, again to avoid warping. Now enjoy building your Bismarck!

Liniencode:

- · - · - · - · - · - ·	Score on the printed side and fold down.	
- - - - - - - - - - -	Score on back side and fold up. Make pinholes at the ends of the lines, turn over and score between them.	
- · - · - · - · - · - ·	Outline of area on which another part is glued. The number inside the area is that of the part to be attached.	
→	Cut along this line.	
Ⓐ	alternative	
Ⓕ	Can be replaced by photo-etched fine detail components (extra set available, not included).	
≡	double	≡≡≡ triple

Bb = Port (left), Stb = Starboard (right) V = bow H = stern

1. Teile/parts U1, Bogen/sheets 1-3

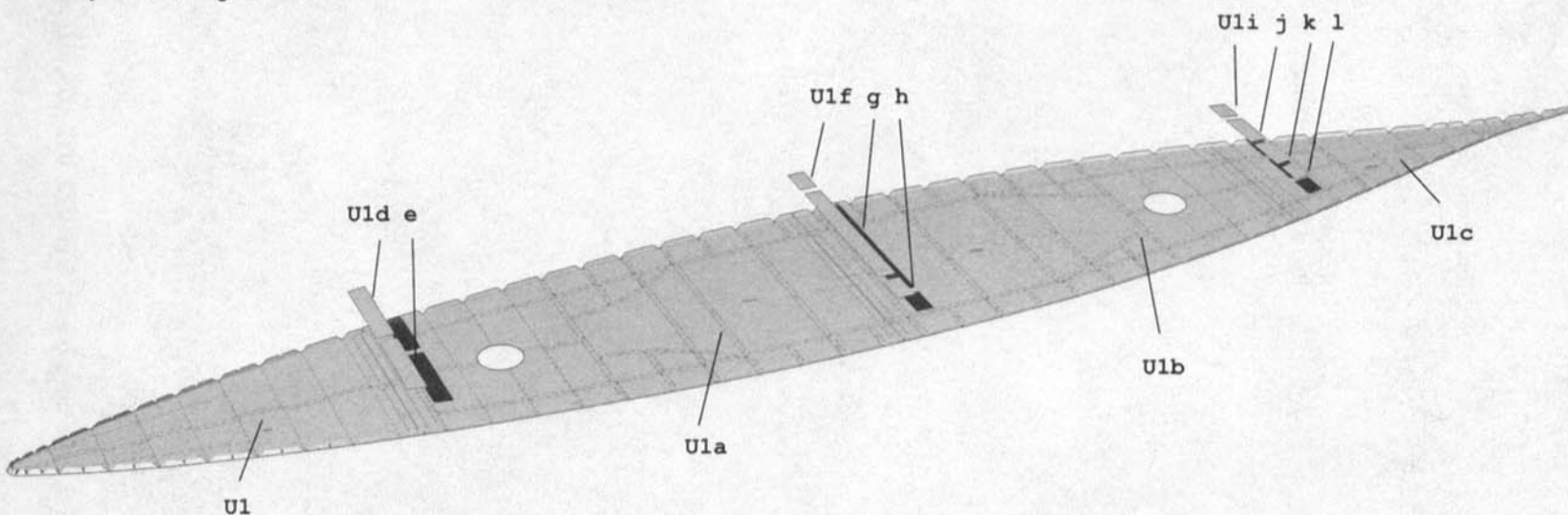

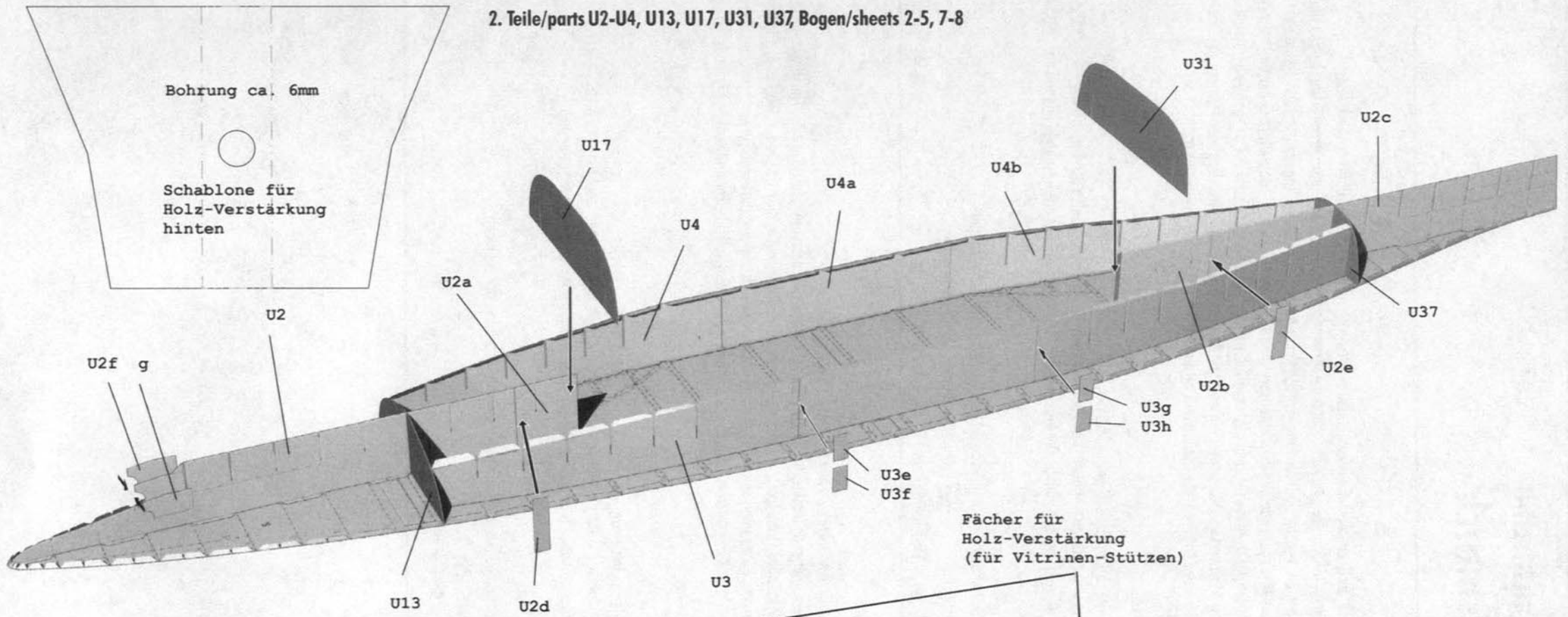

2. Teile/parts U2-U4, U13, U17, U31, U37, Bogen/sheets 2-5, 7-8

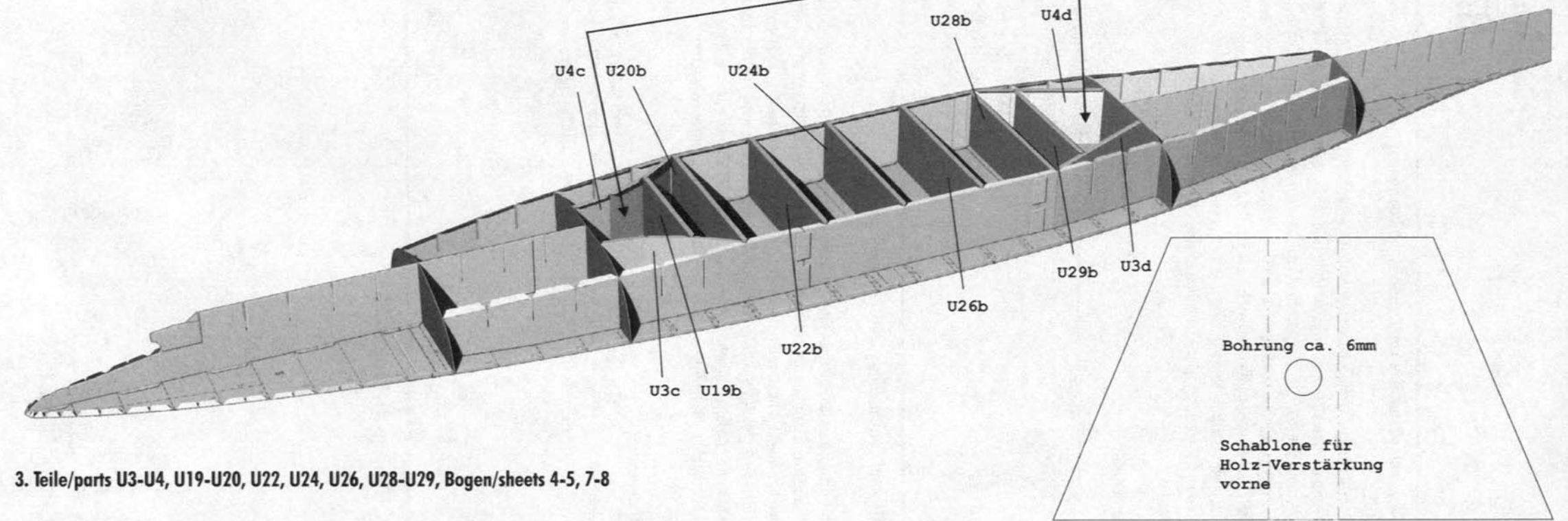

3. Teile/parts U3-U4, U19-U20, U22, U24, U26, U28-U29, Bogen/sheets 4-5, 7-8

Montage-Vorschlag

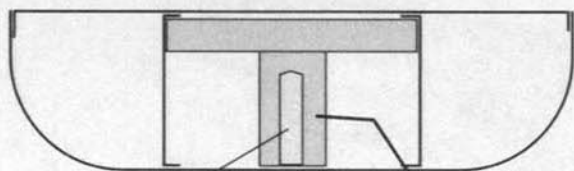

Bohrung 6mm,
Tiefe ca. 25mm



Stütze

Vitrinen-
Grundbrett

4. Teile/parts U5-U43, Bogen/sheets 1-2, 4-8

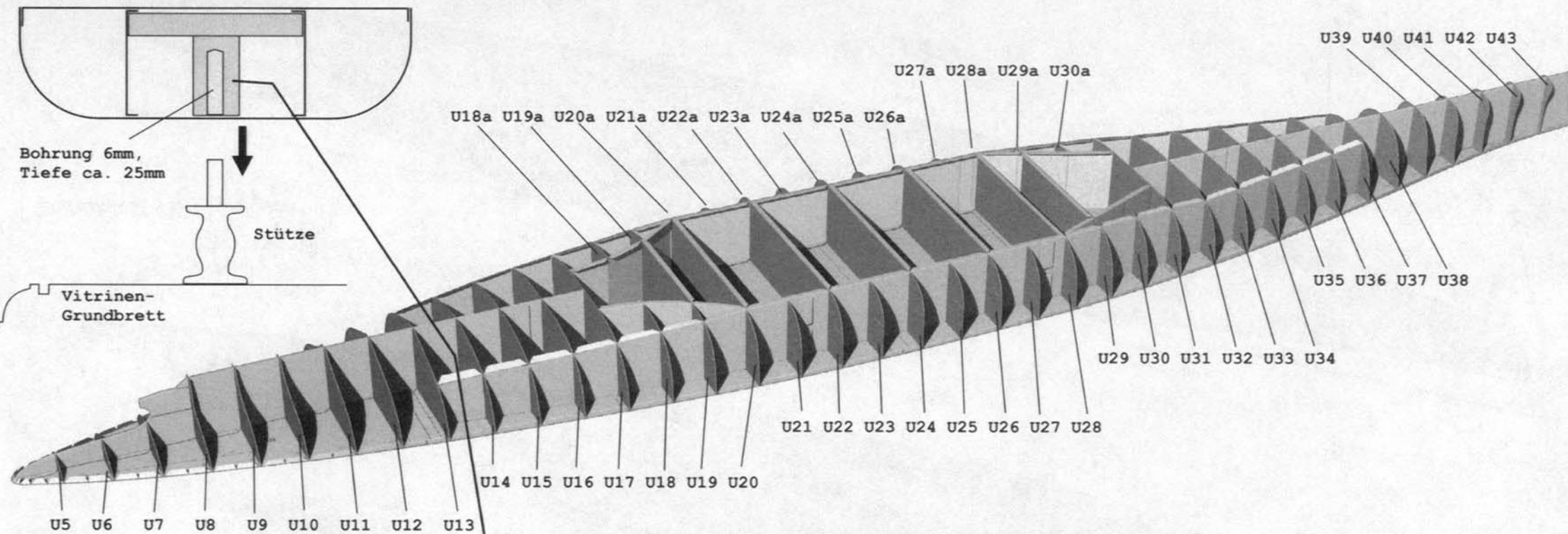

5. Teile/parts U44-U49, Bogen/sheets 1-3, 6

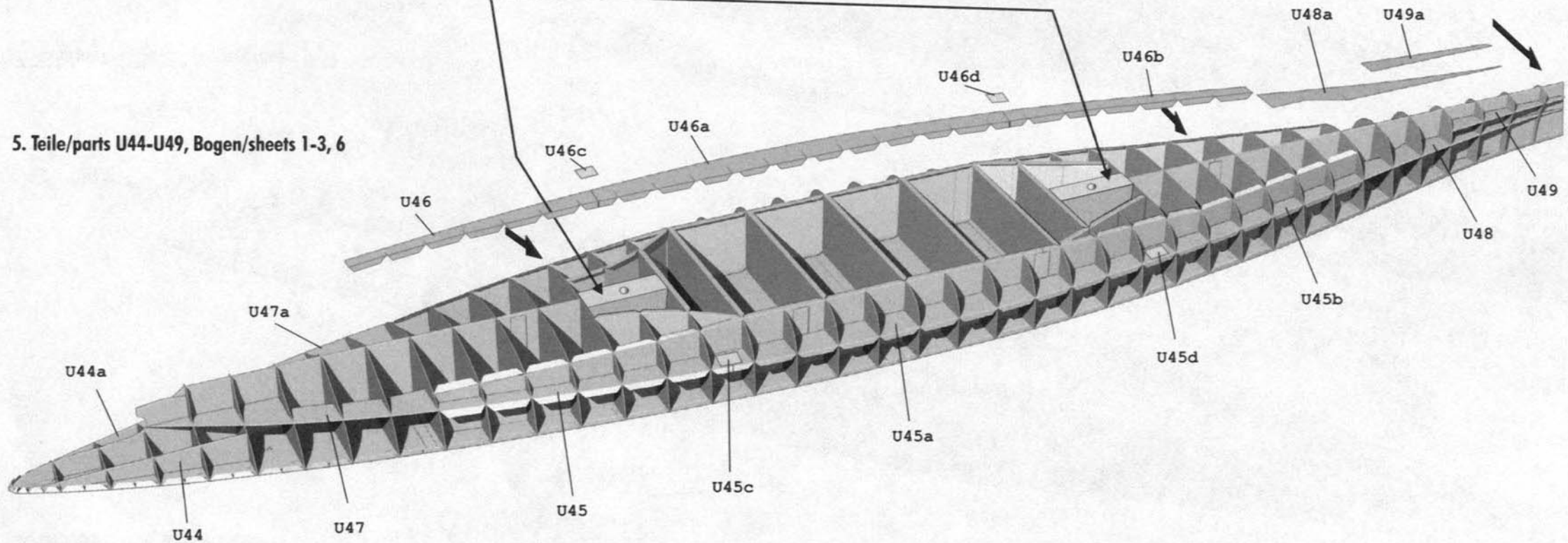

6. Teile/parts U50, Bogen/sheets 12

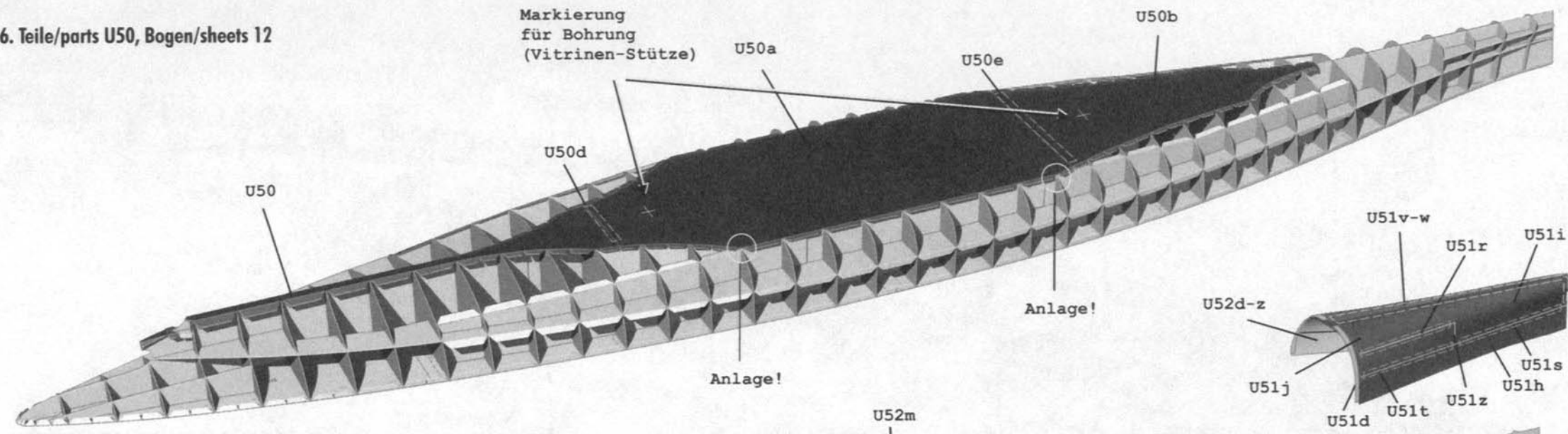

7. Teile/parts U51-U52, Bogen/sheets 9-11

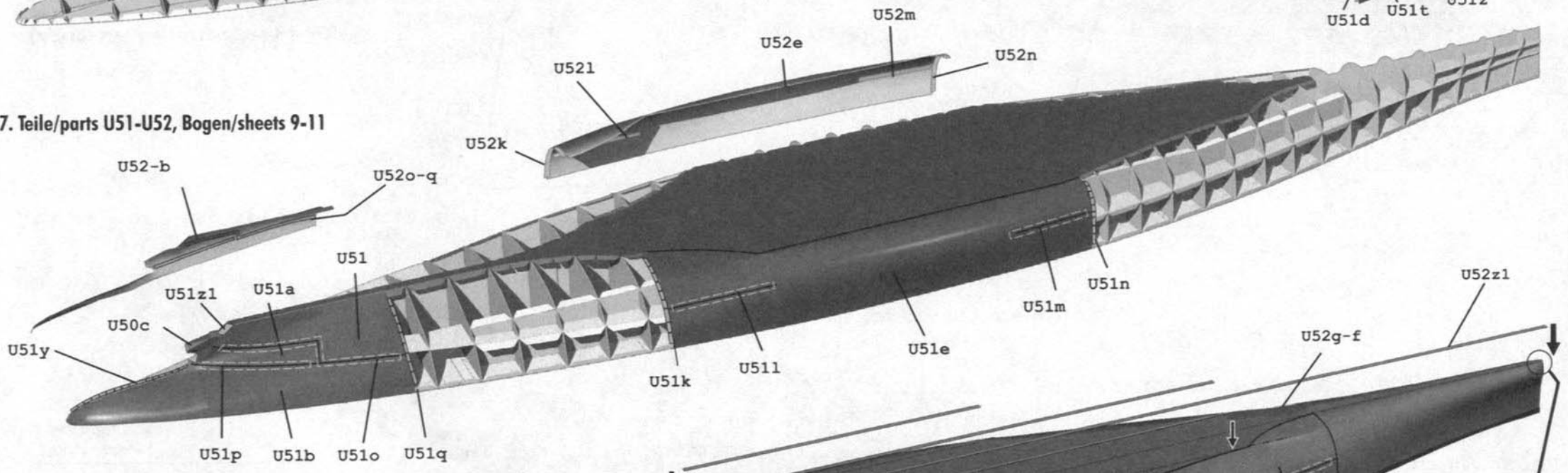

8. Teile/parts U51-U52, Bogen/sheets 9-10, 12

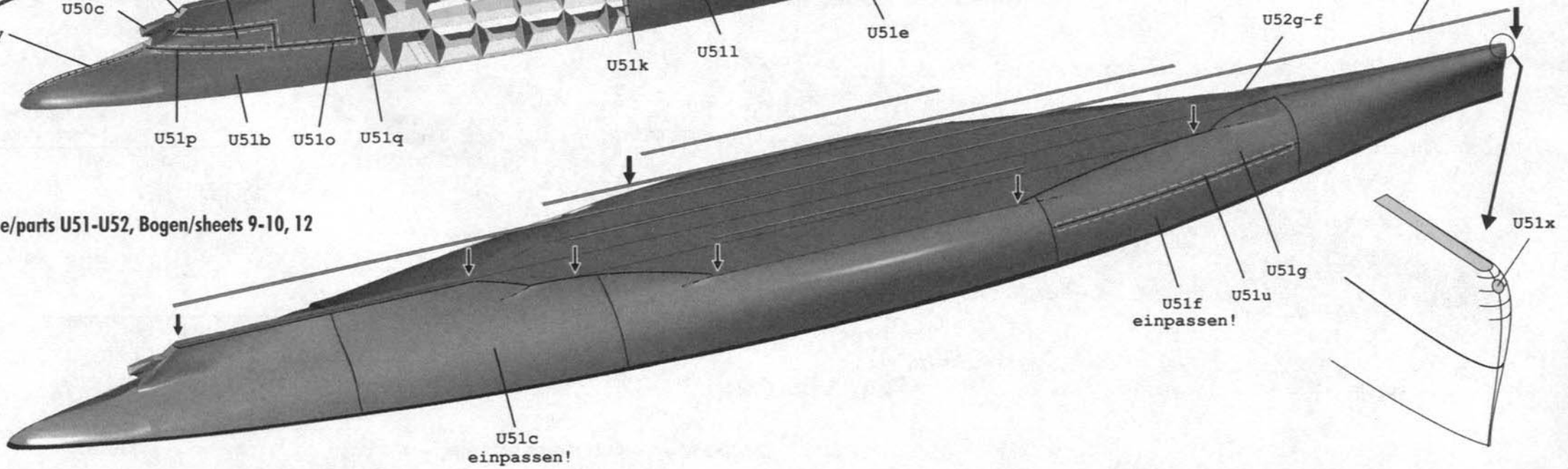

9. Teile/parts U53-U58, Bogen/sheets 9, 11, 53

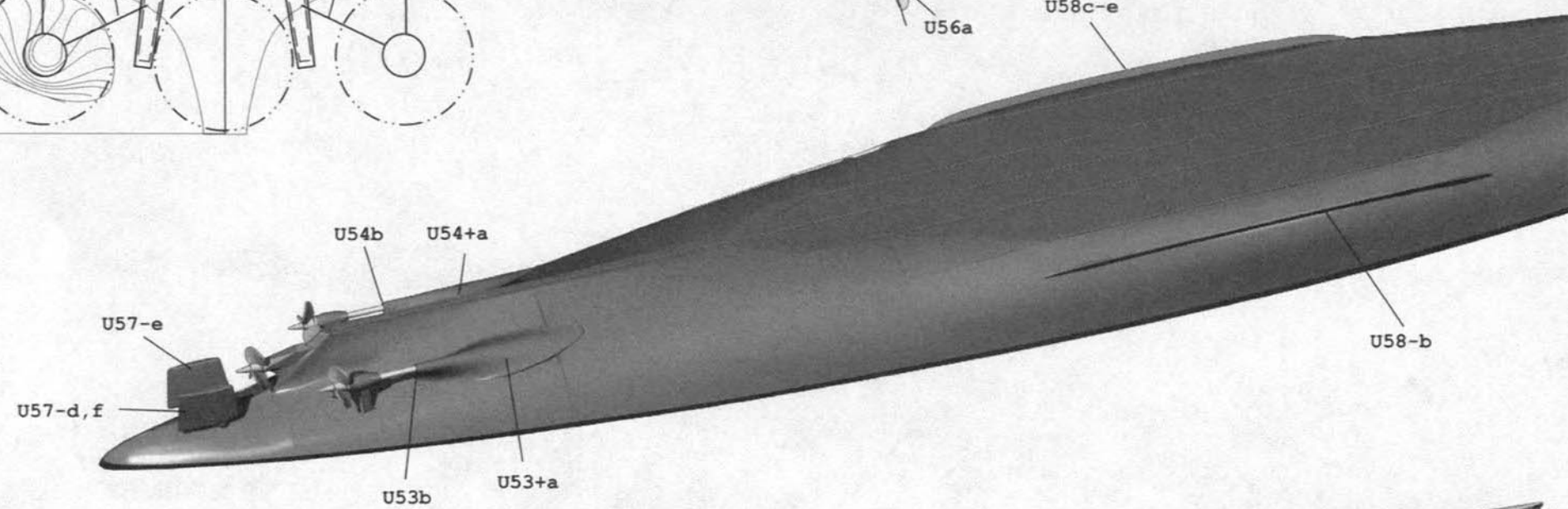
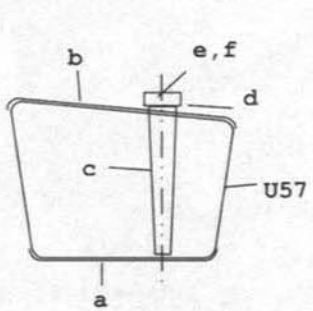
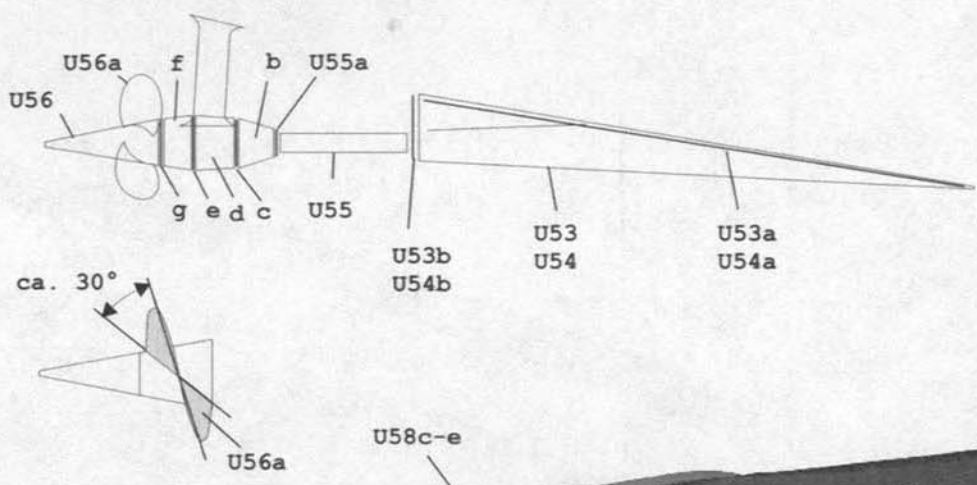
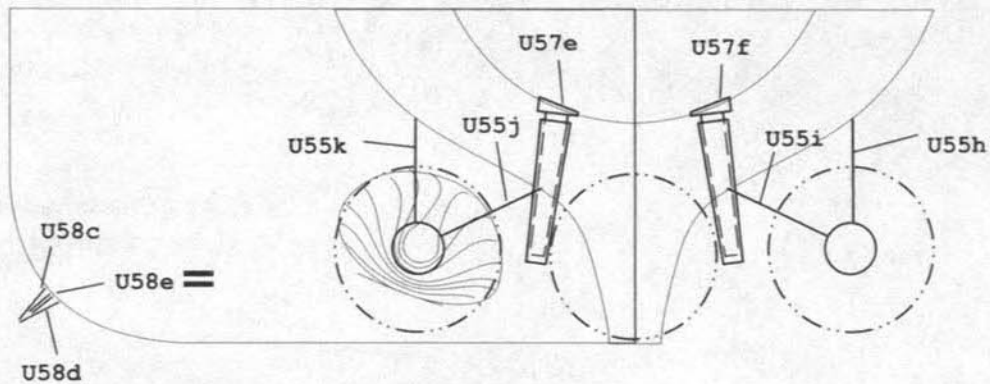

10. Teile/parts U59, Bogen/sheet 19

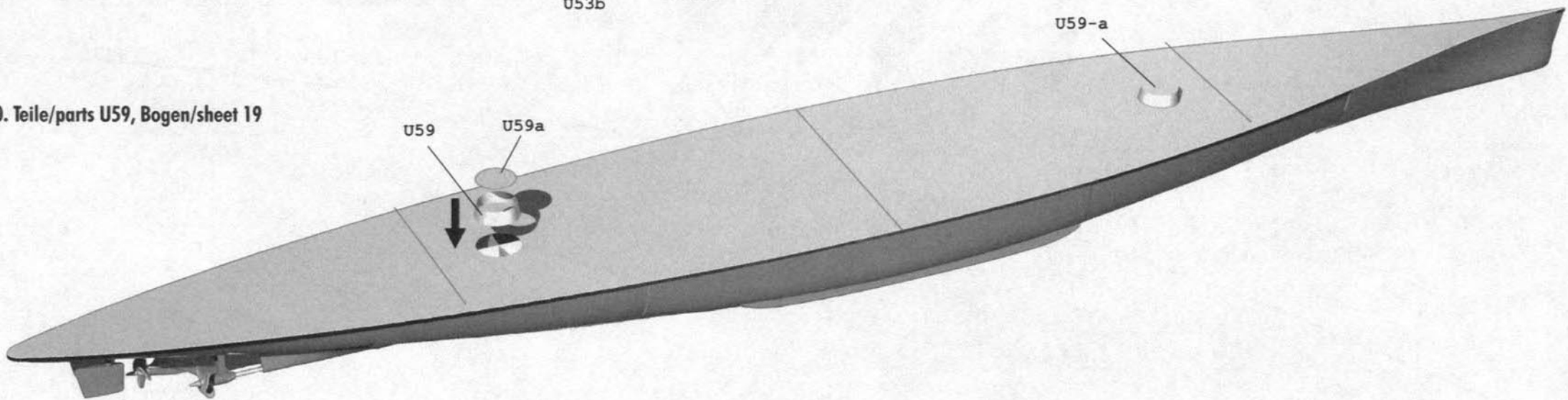

11. Teile/parts 1 - 1n, Bogen/sheets 13 - 15

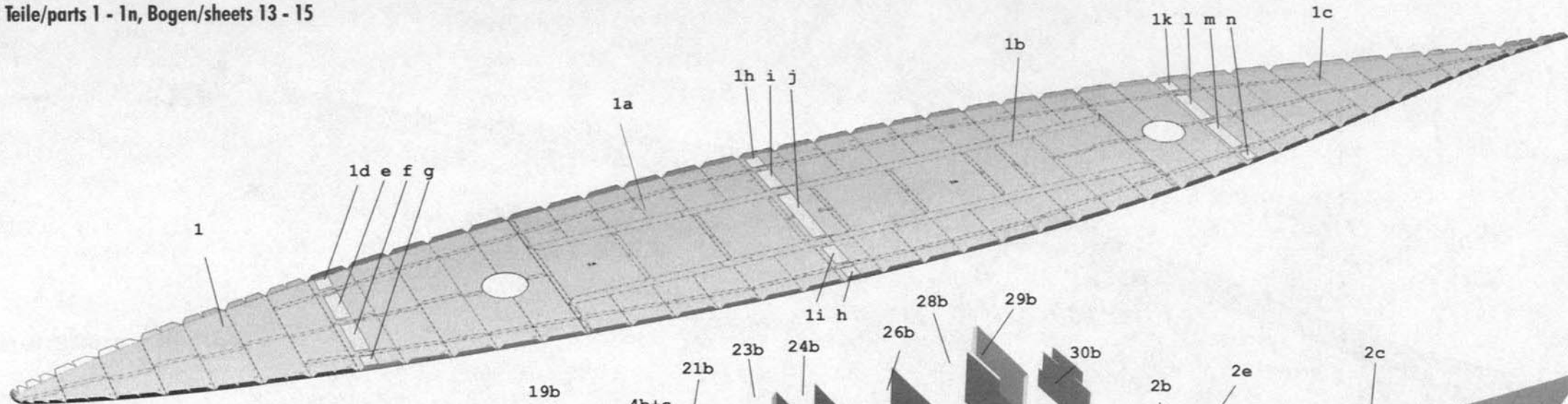

12. Teile/parts 2-4, 17, 19b, 21b, 23b+c, 24b, 26b, 28b, 29b, 30b, 32
Bogen/sheets 13-16, 18-20

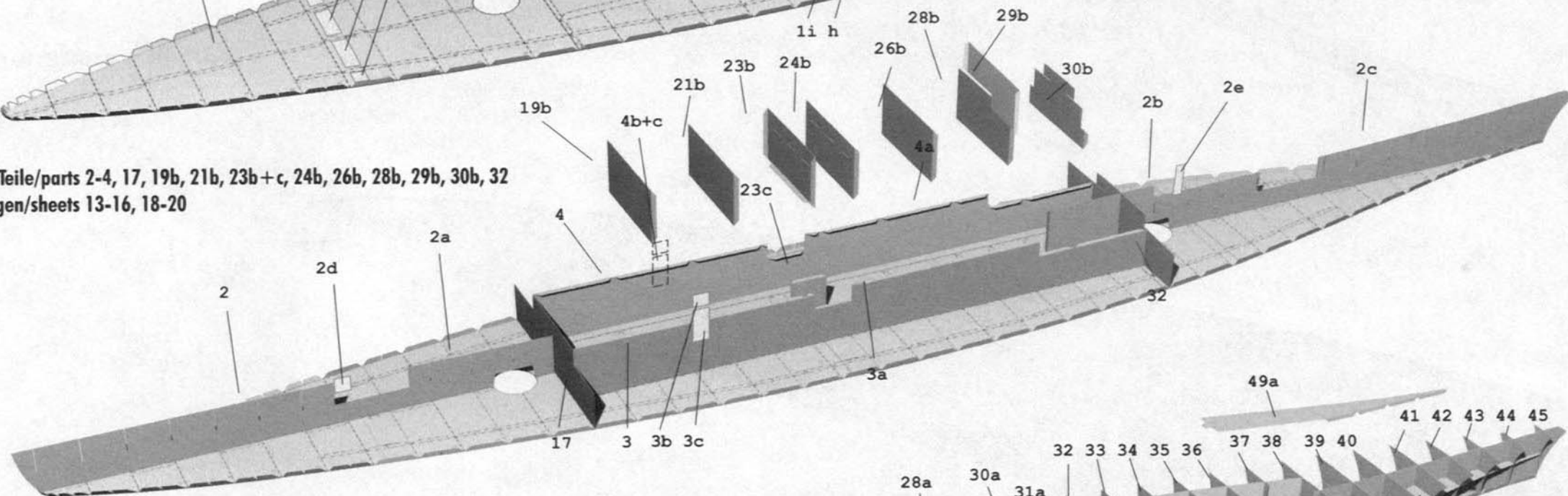

13. Teile/parts 5-16, 18-31, 33-50
Bogen/sheets 13, 16-20

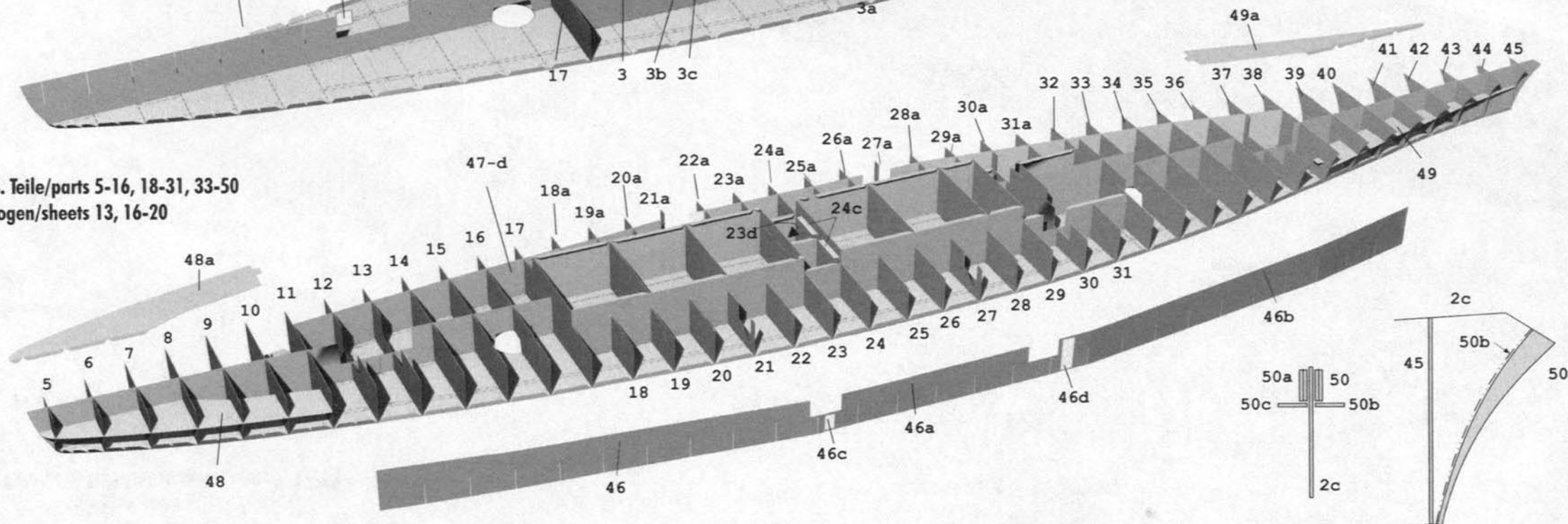

14. Teile/parts 51, Bogen/sheets 21-24

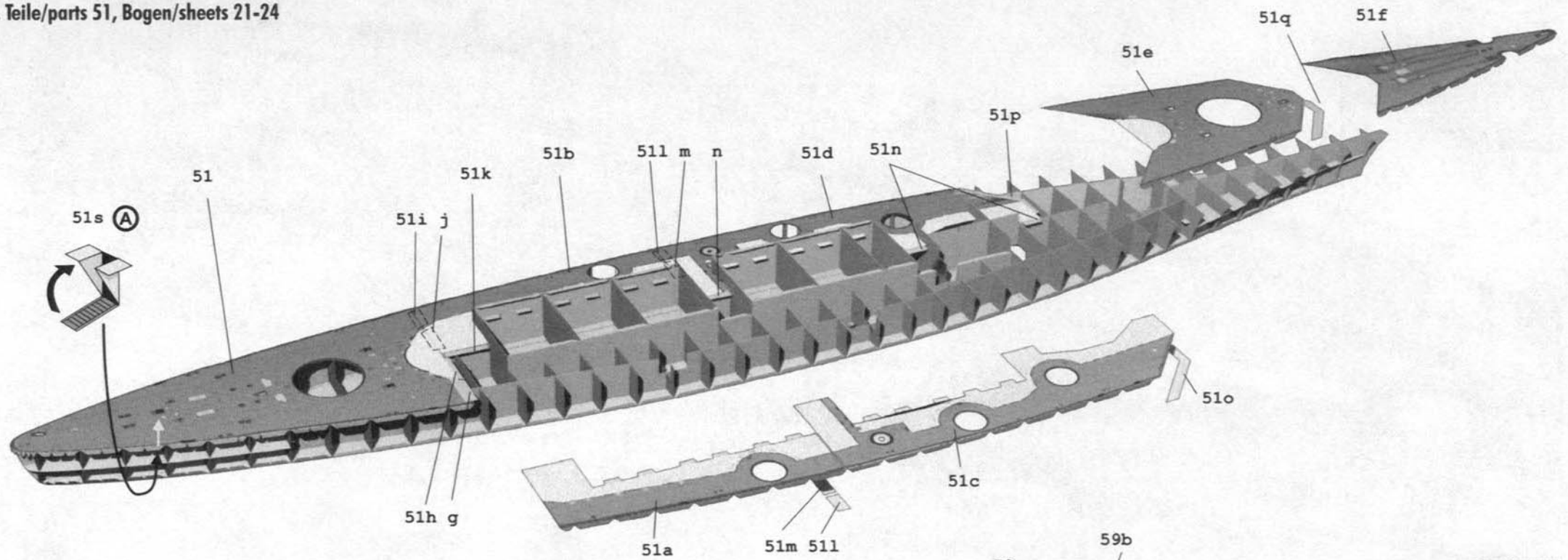

15. Teile/parts 52-59, Bogen/sheets 25-26

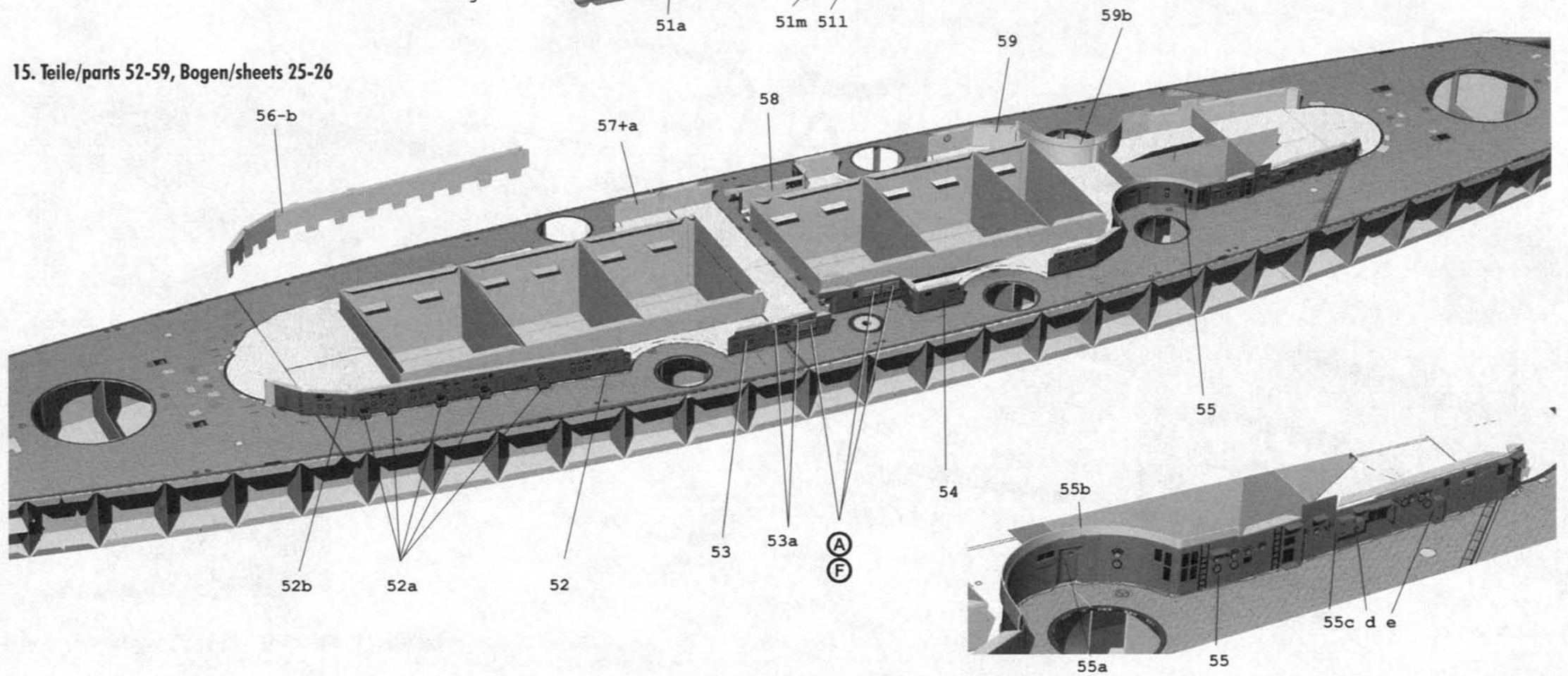

16. Teile/parts 60-67, 224-233, Bogen/sheets 25-26, 40

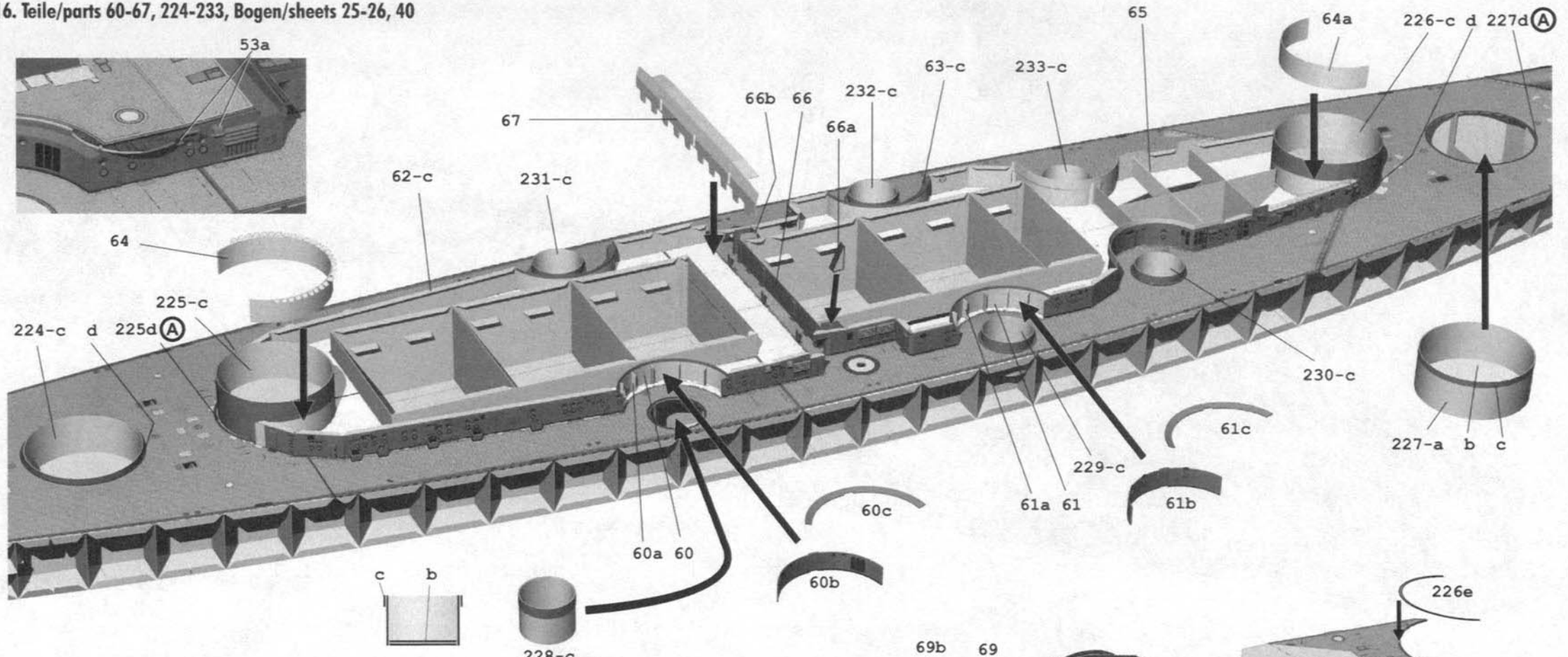

17. Teile/parts 67a-69b, Bogen/sheets 22, 25-26

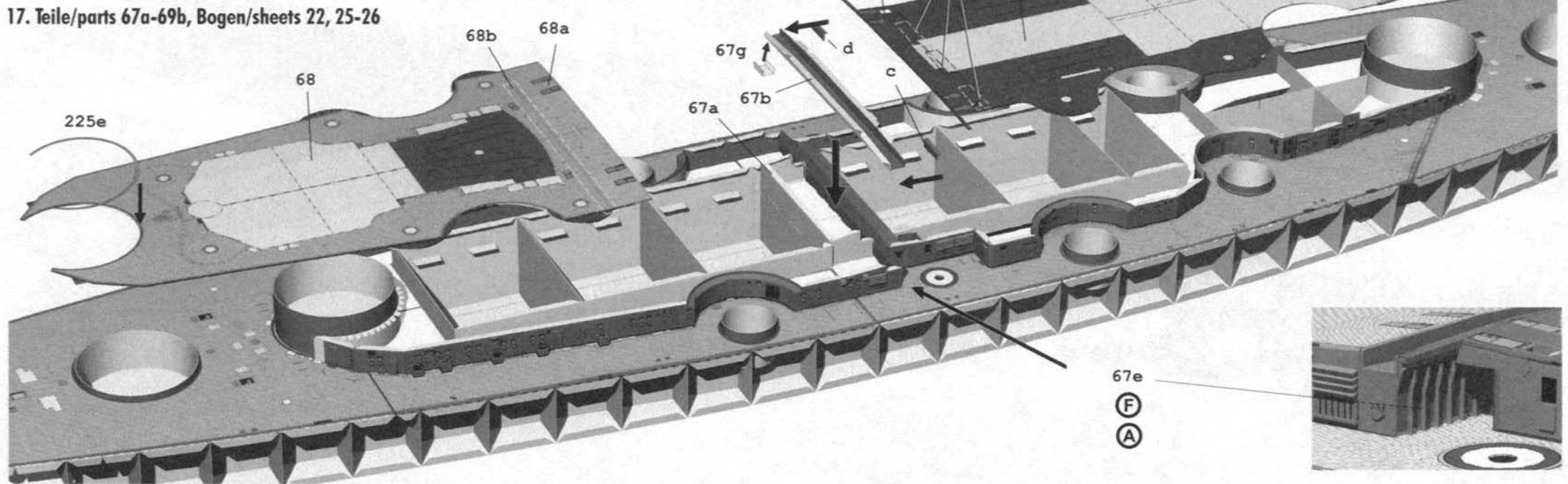

18. Teile/parts 69-76, Bogen/sheets 22, 24, 27-28,

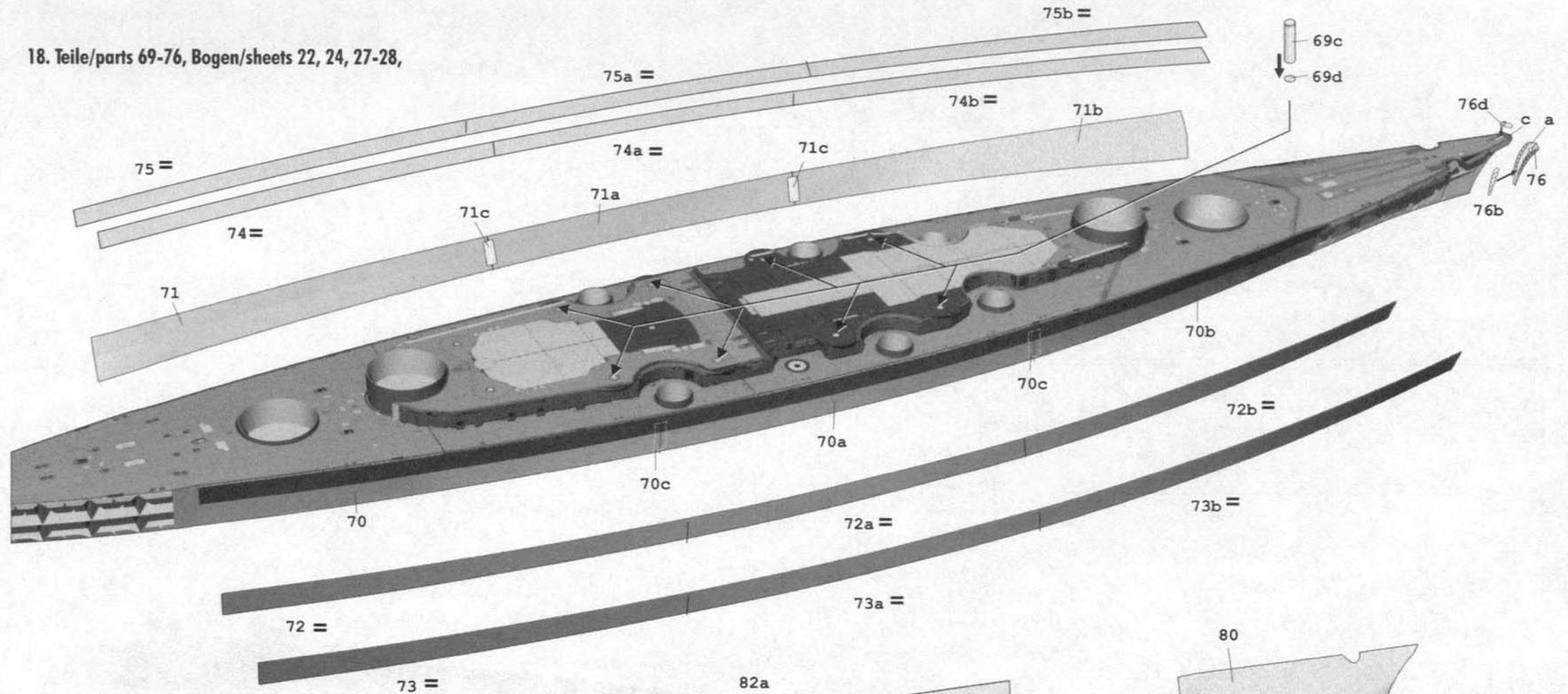

19. Teile/parts 77-82, Bogen/sheets 21-22, 24

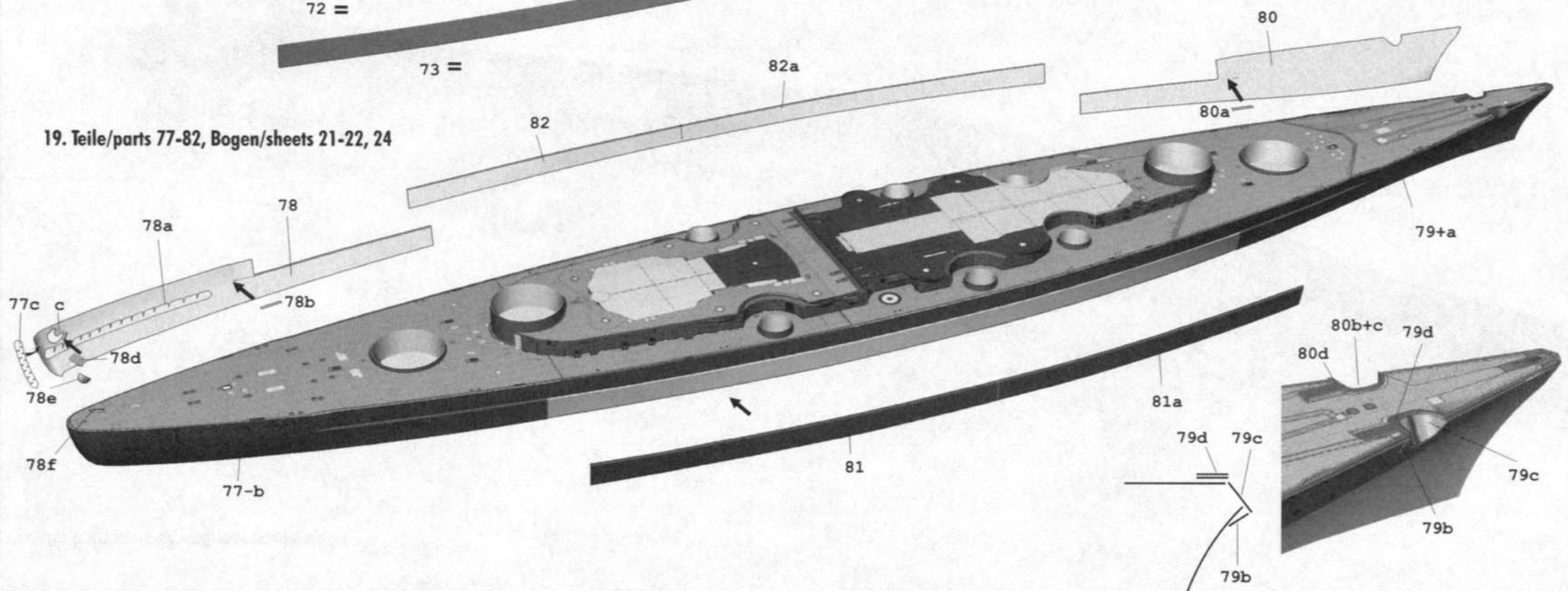

20. Teile/parts 83 - 84, Bogen/sheets 20

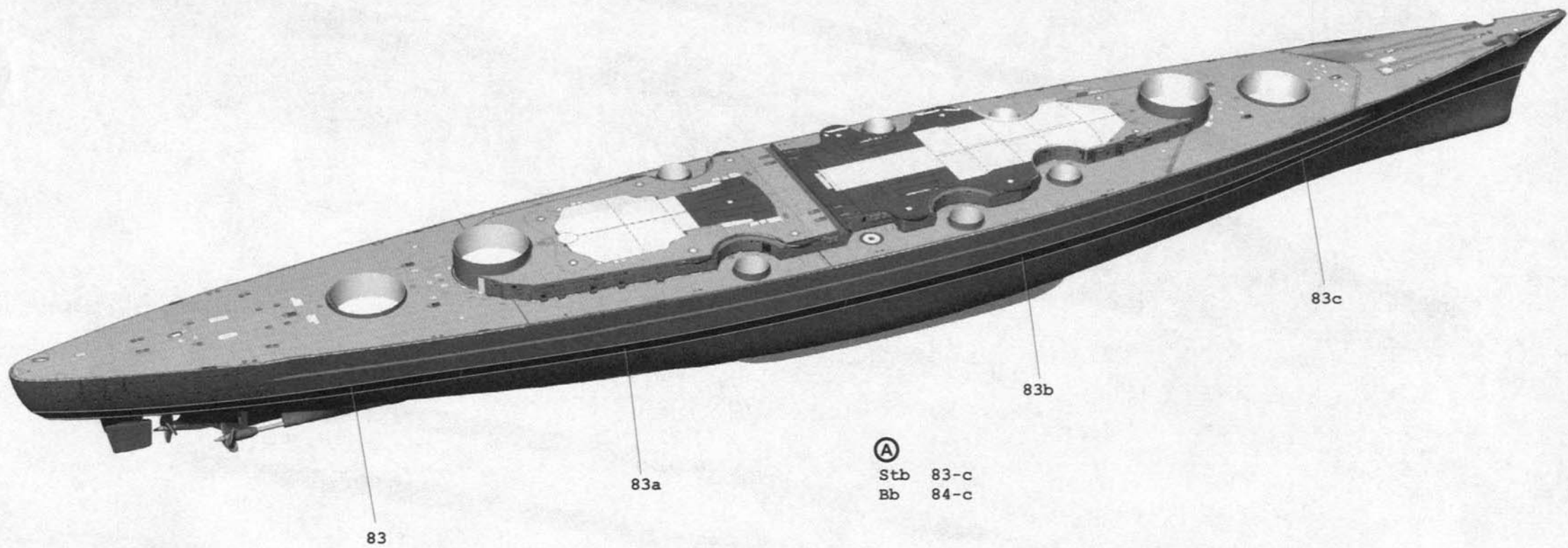

- Ⓐ
Stb 83-c
Bb 84-c

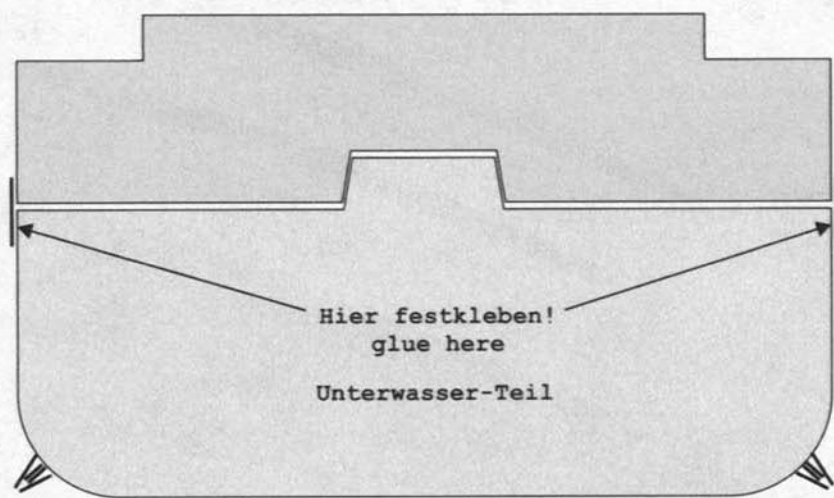

21. Teile/parts 85, Bogen/sheets 29

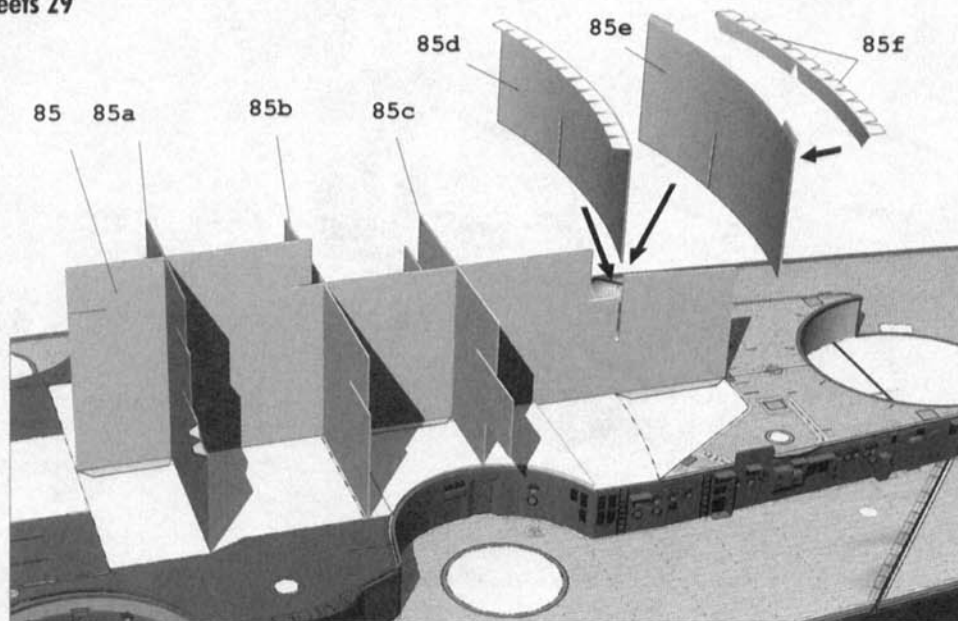

22. Teile/parts 86 - 88, Bogen/sheets 29

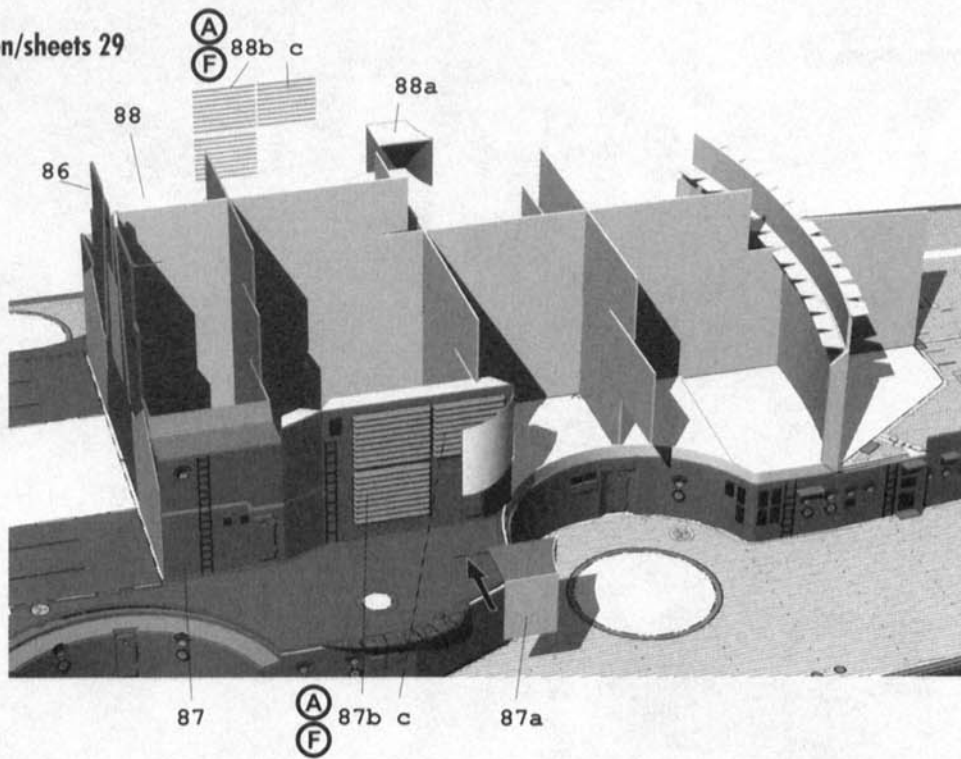

23. Teile/parts 89, Bogen/sheets 29

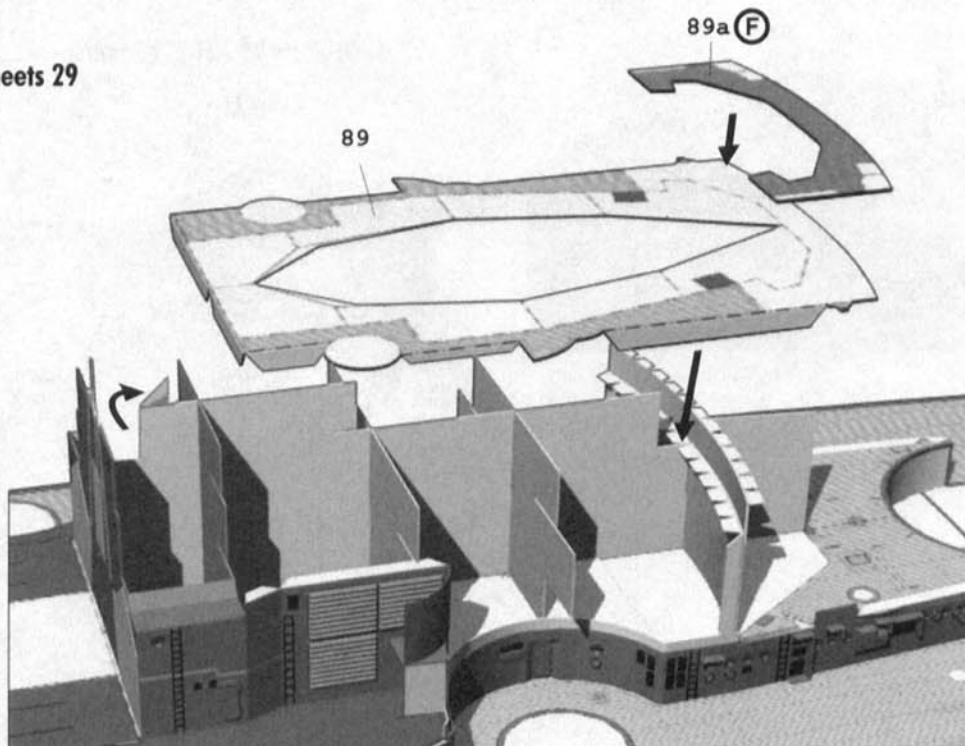

24. Teile/parts 90, Bogen/sheets 29

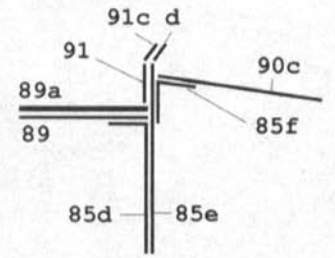
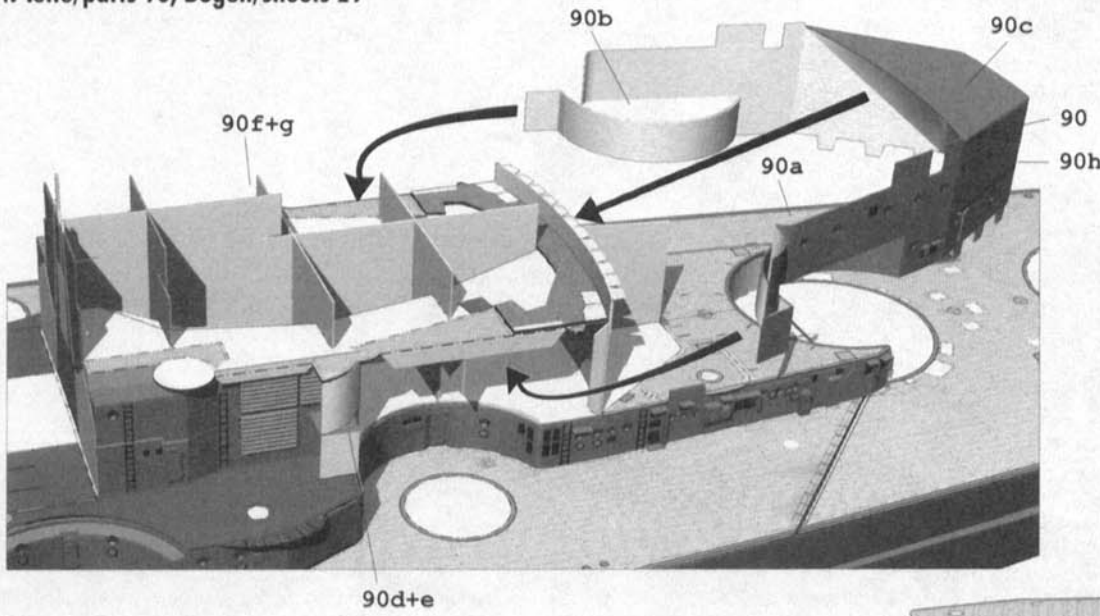

25. Teile/parts 89b+c, 91 - 95, Bogen/sheets 29-30

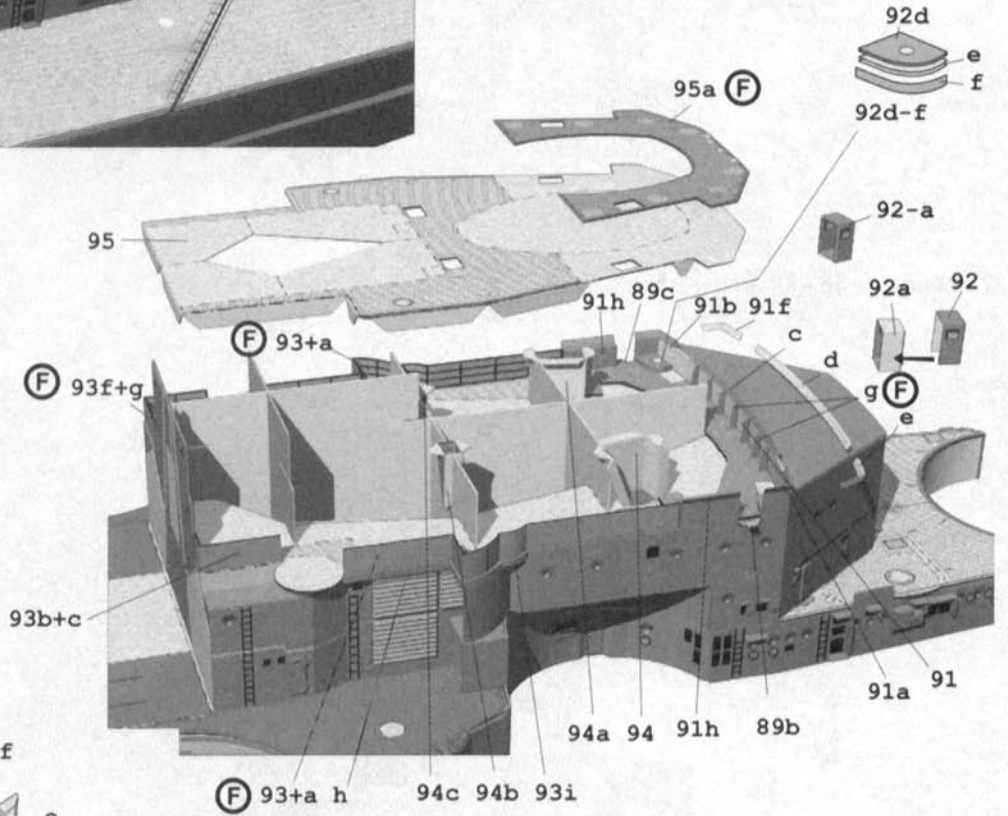

26. Teile/parts 96 - 99, Bogen/sheets 30

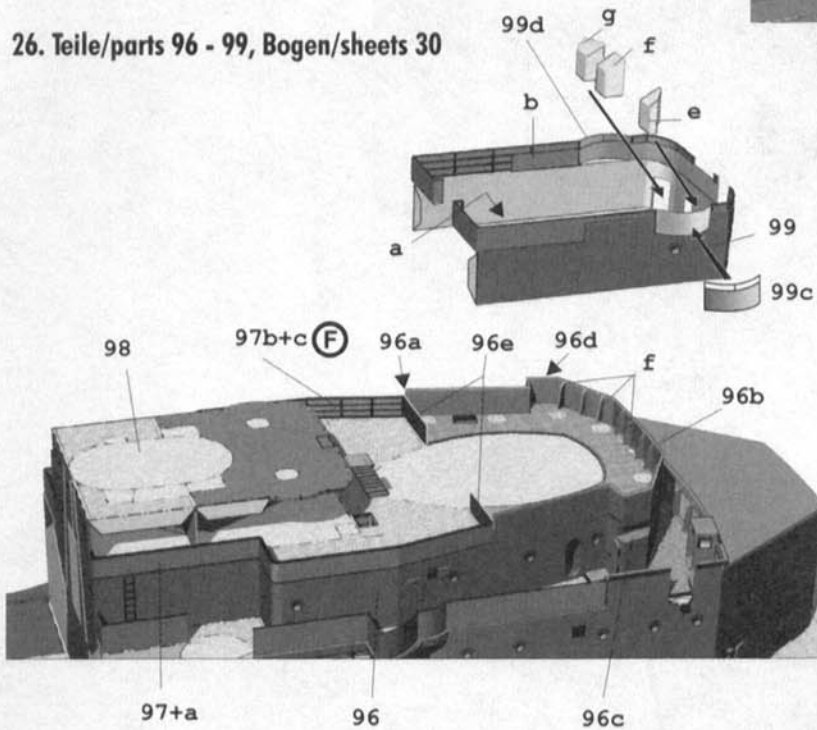

27. Teile/parts 99 - 102, Bogen/sheets 30

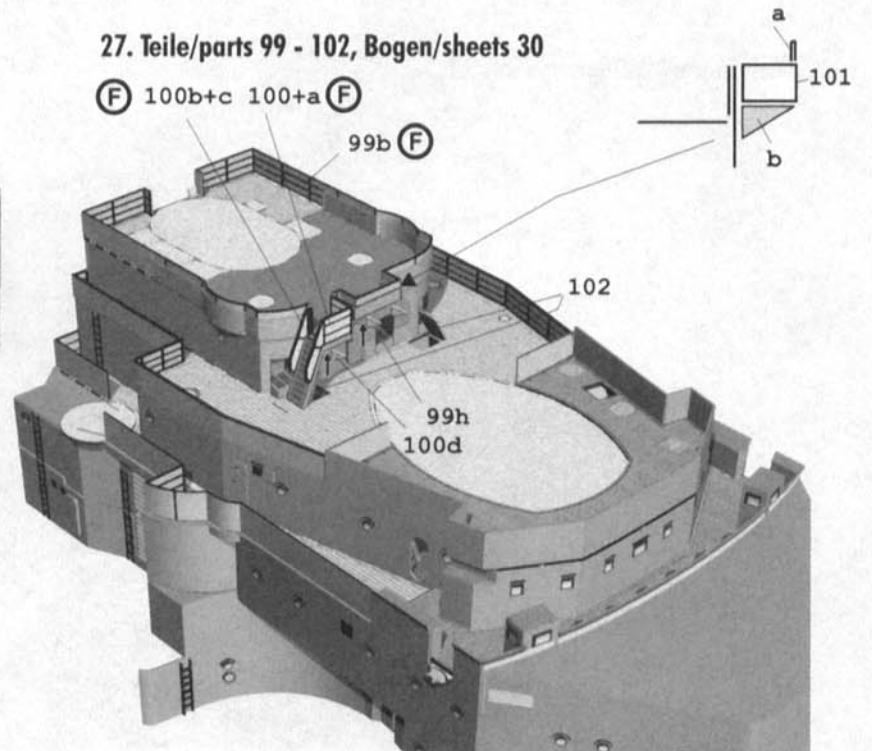

28. Teile/parts 103 - 104, Bogen/sheets 30, 34

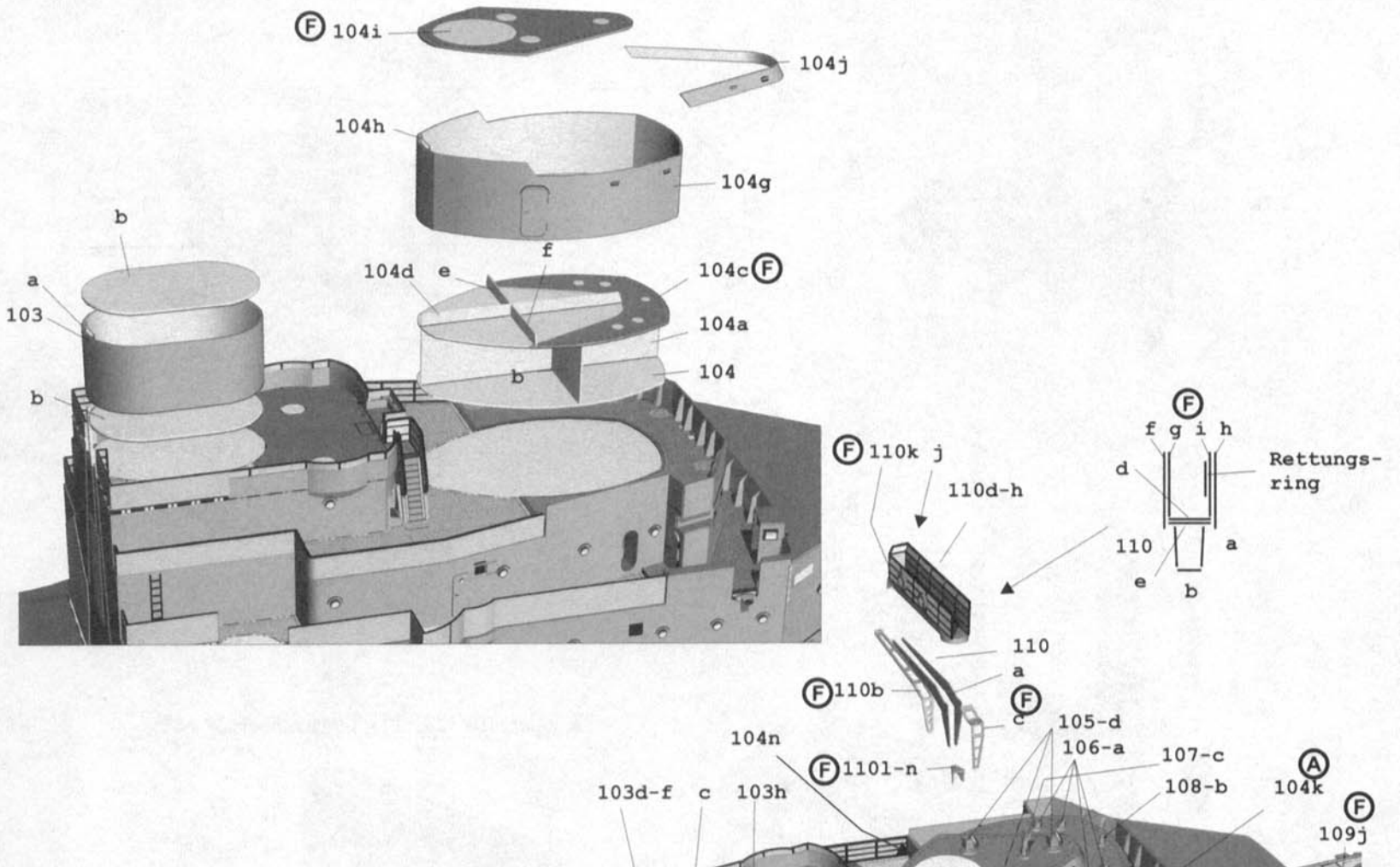

29. Teile/parts 103 - 115, Bogen/sheets 30 -31, 34

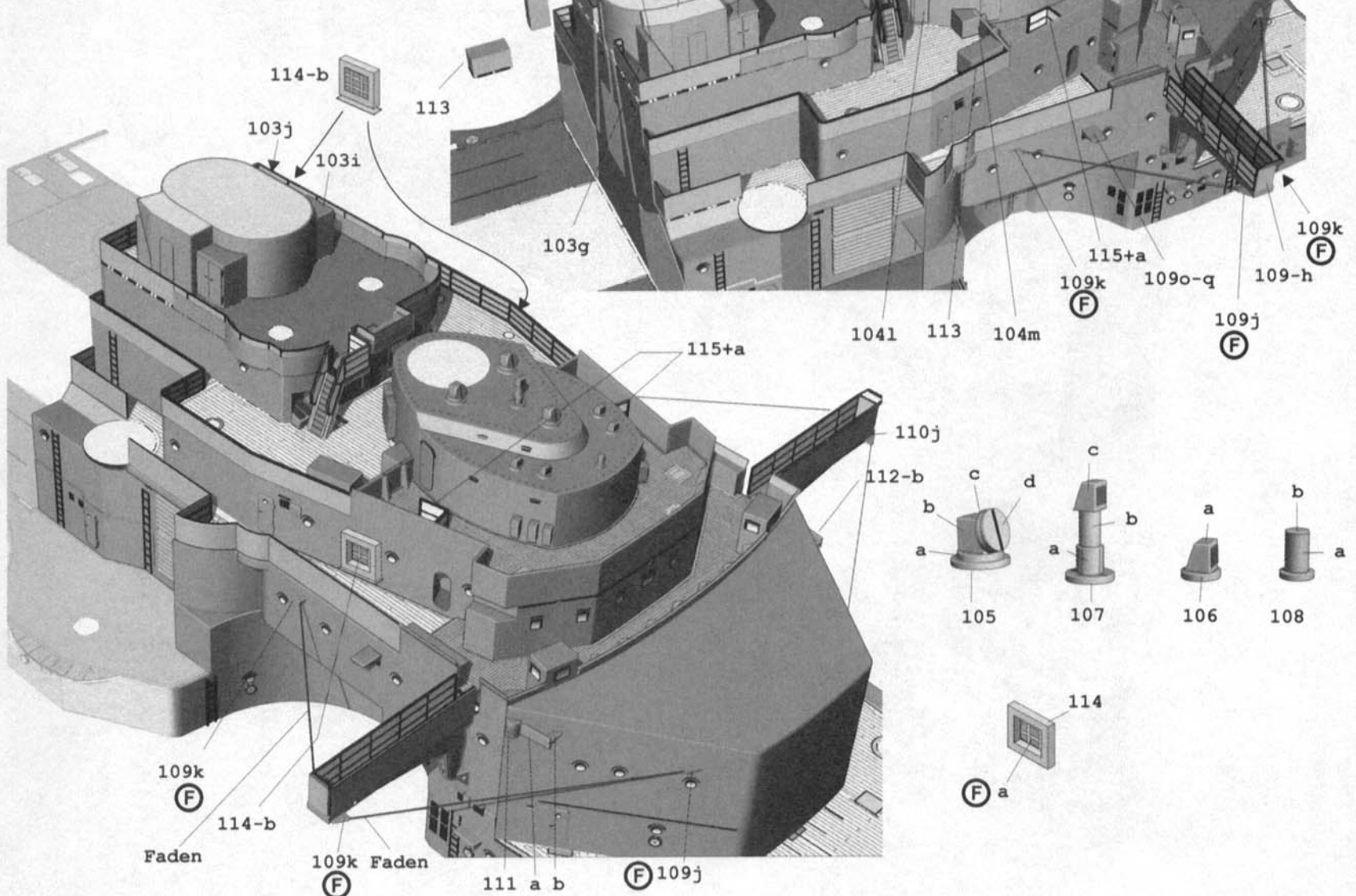

30. Teile/parts 116-119, Bogen/sheets 31

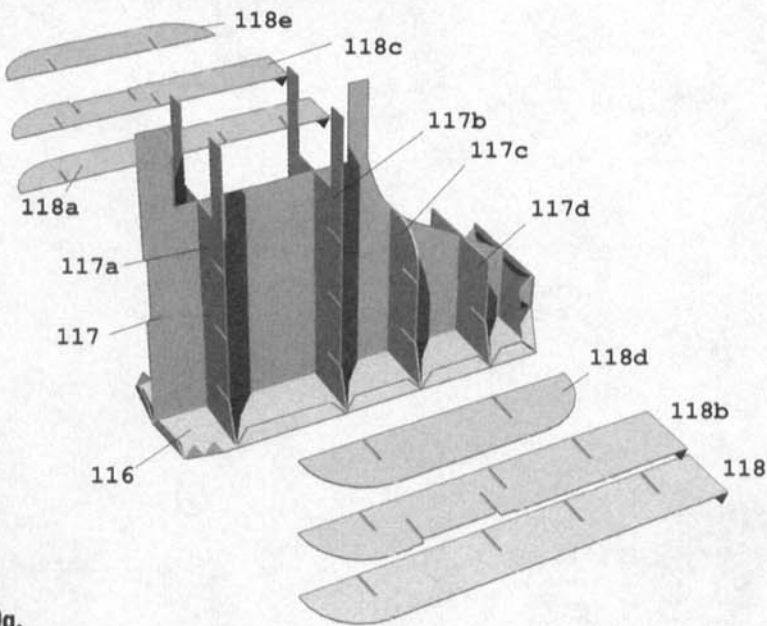

30a.

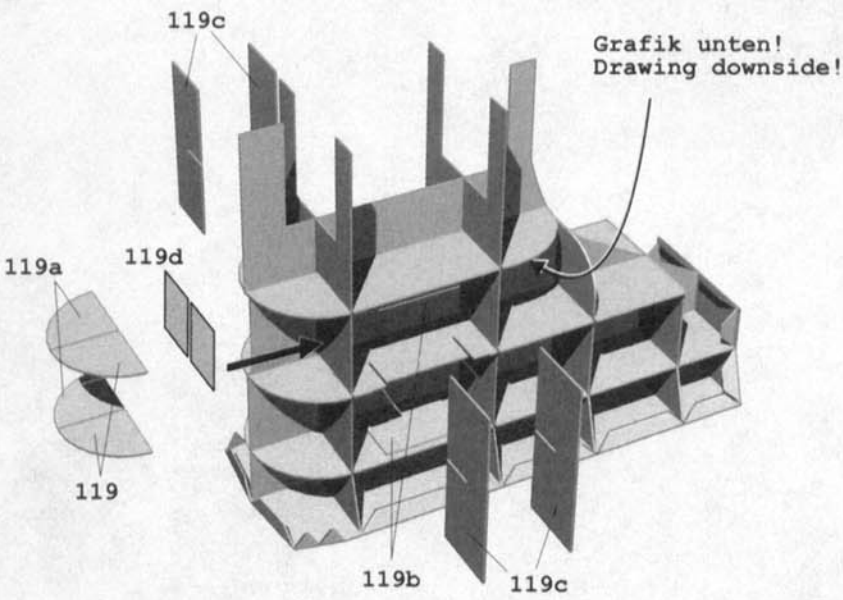

31. Teile/parts 120 - 122, Bogen/sheets 31, 32

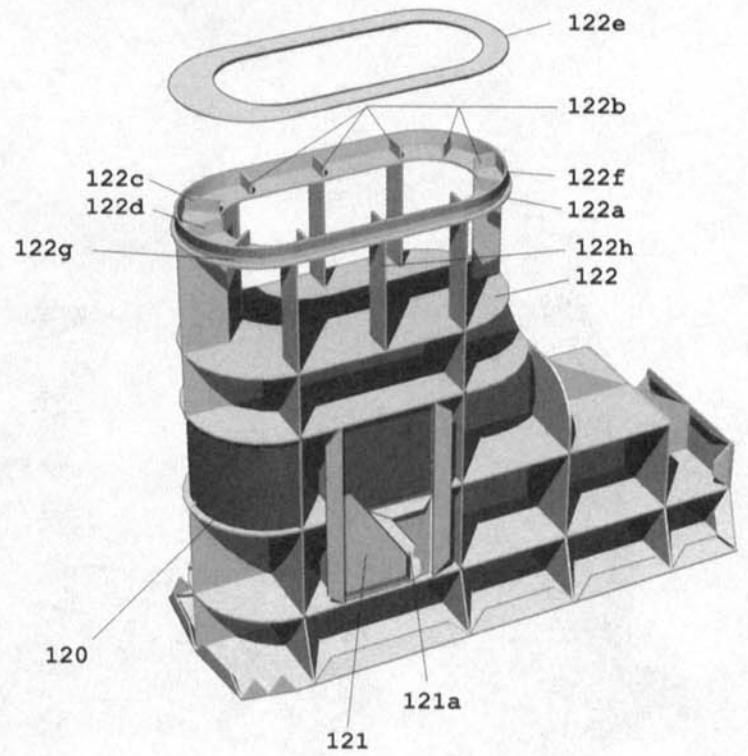

32. Teile/parts 123 - 125, Bogen/sheets 31 - 32

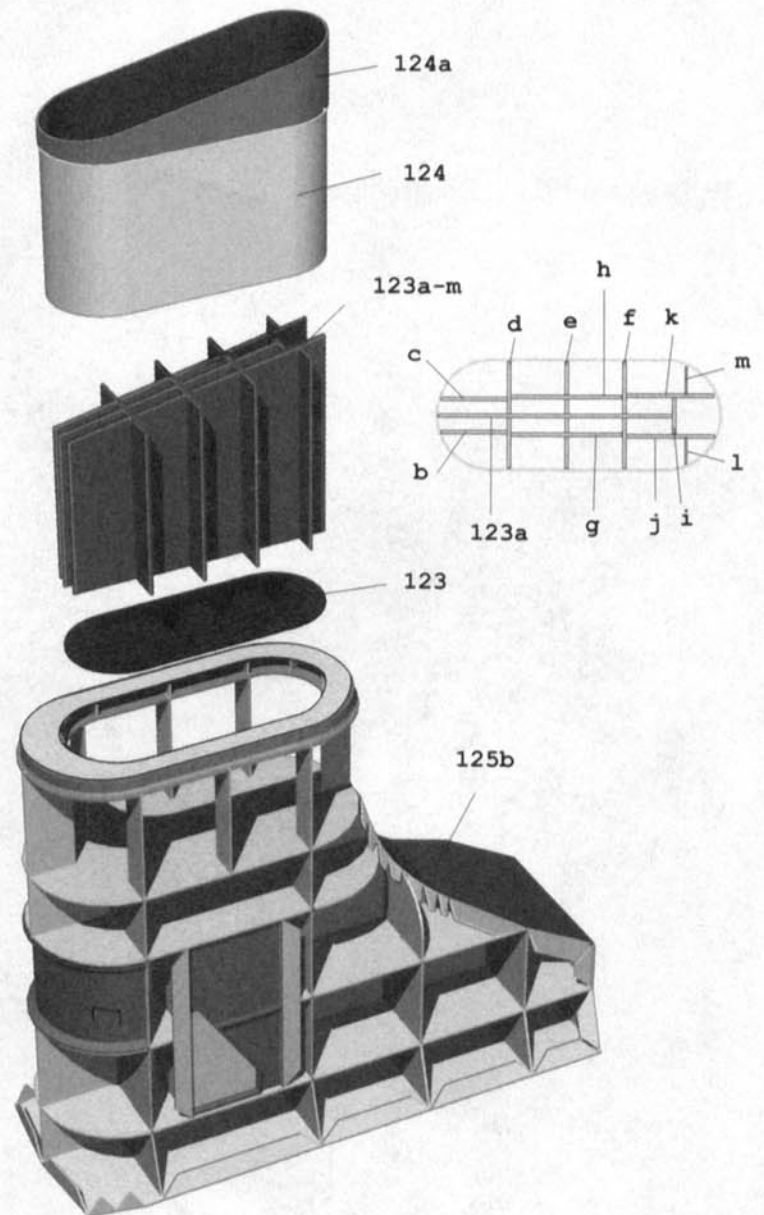

33. Teile/parts 125, Bogen/sheets 32

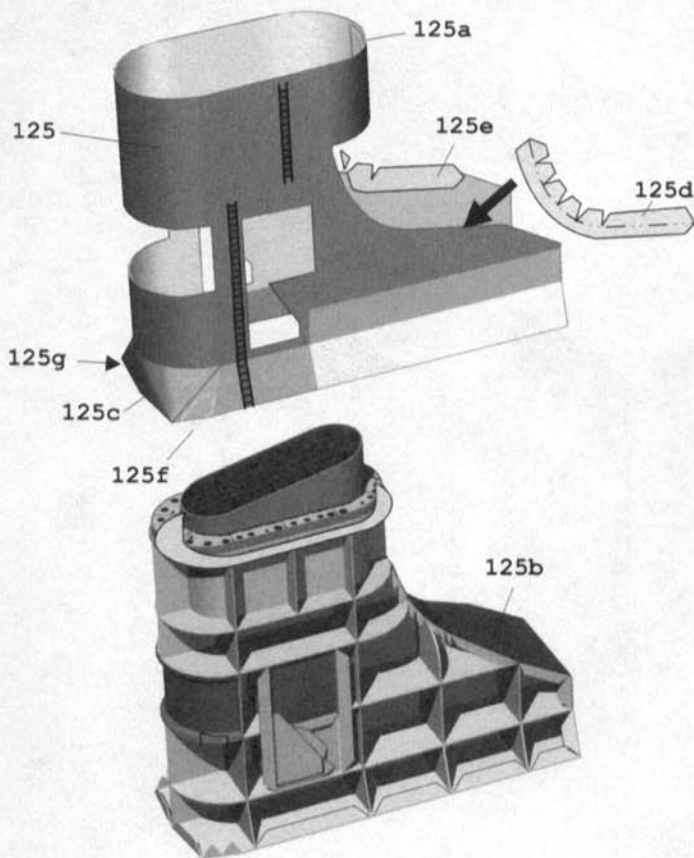

34. Teile/parts 125 - 130, Bogen/sheets 31 - 33

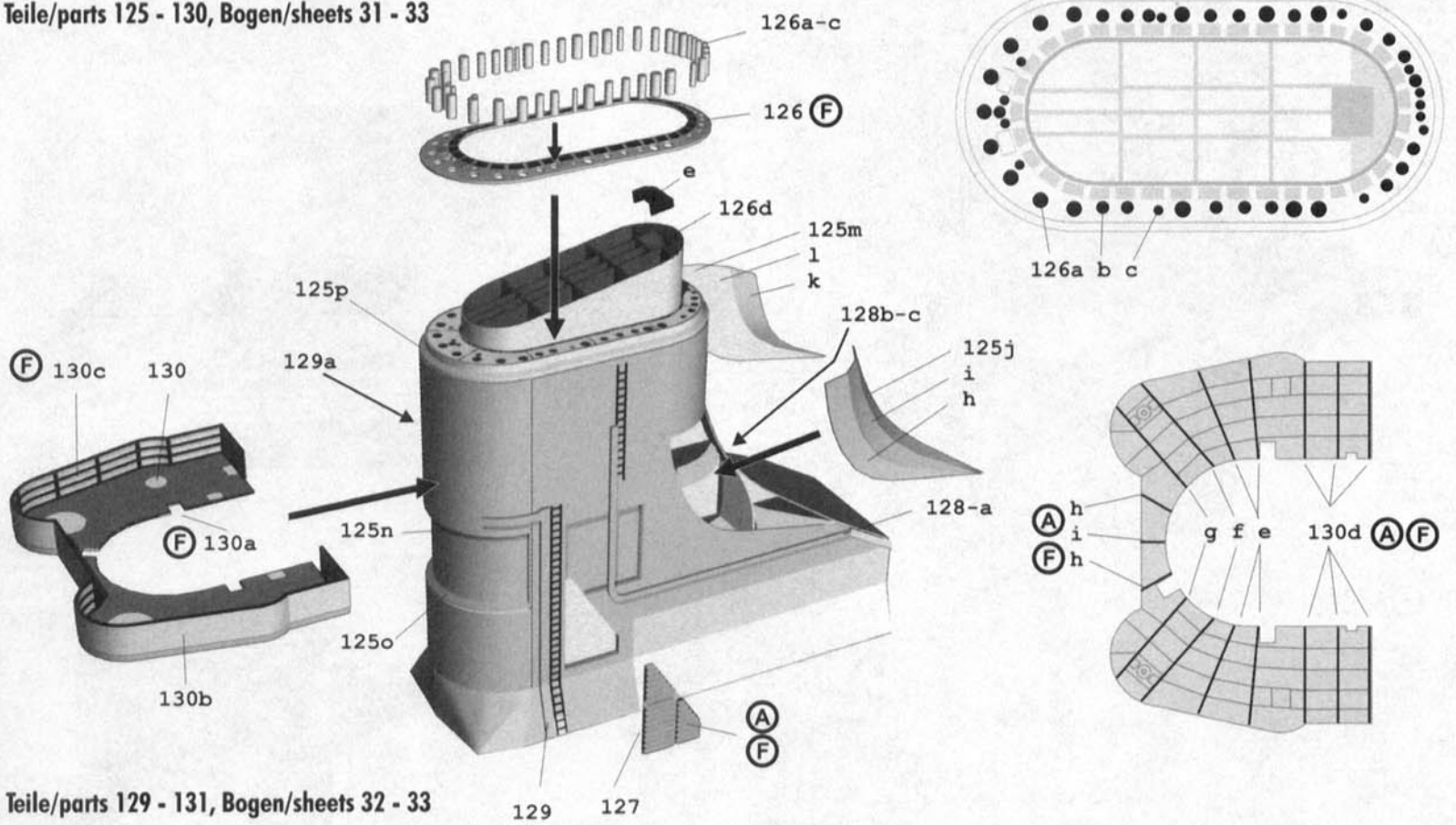

35. Teile/parts 129 - 131, Bogen/sheets 32 - 33

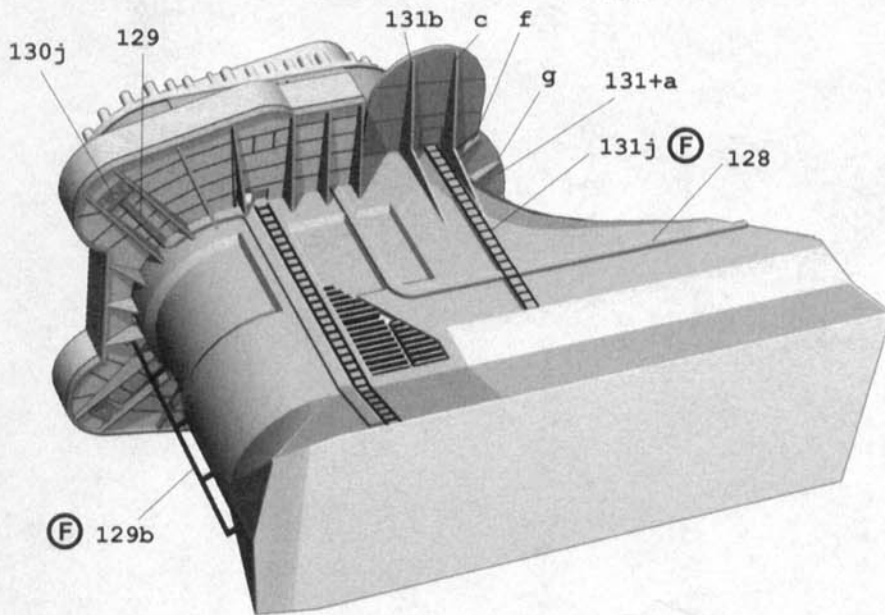

36. Teile/parts 130, 132, Bogen/sheets 32 - 33

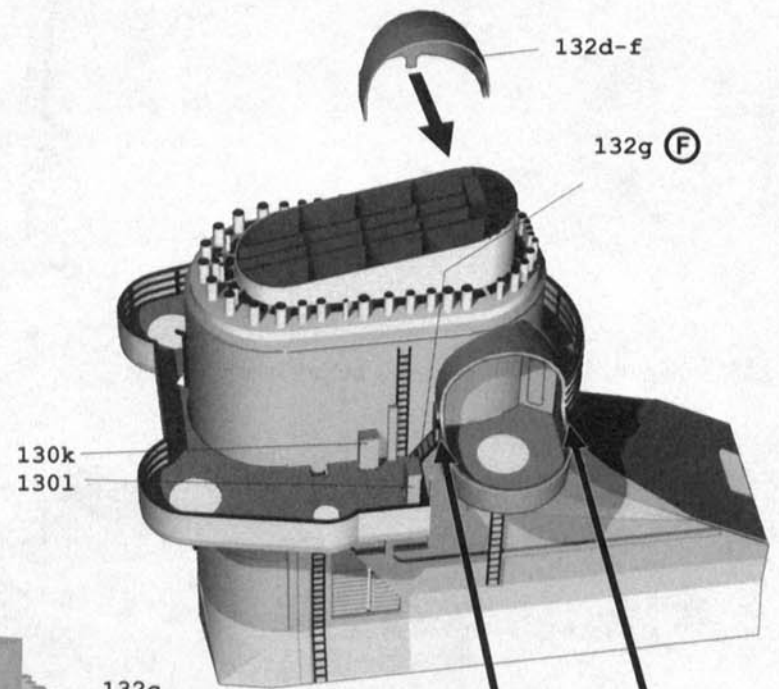

36a. Teile/parts 131 - 132, Bogen/sheets 33

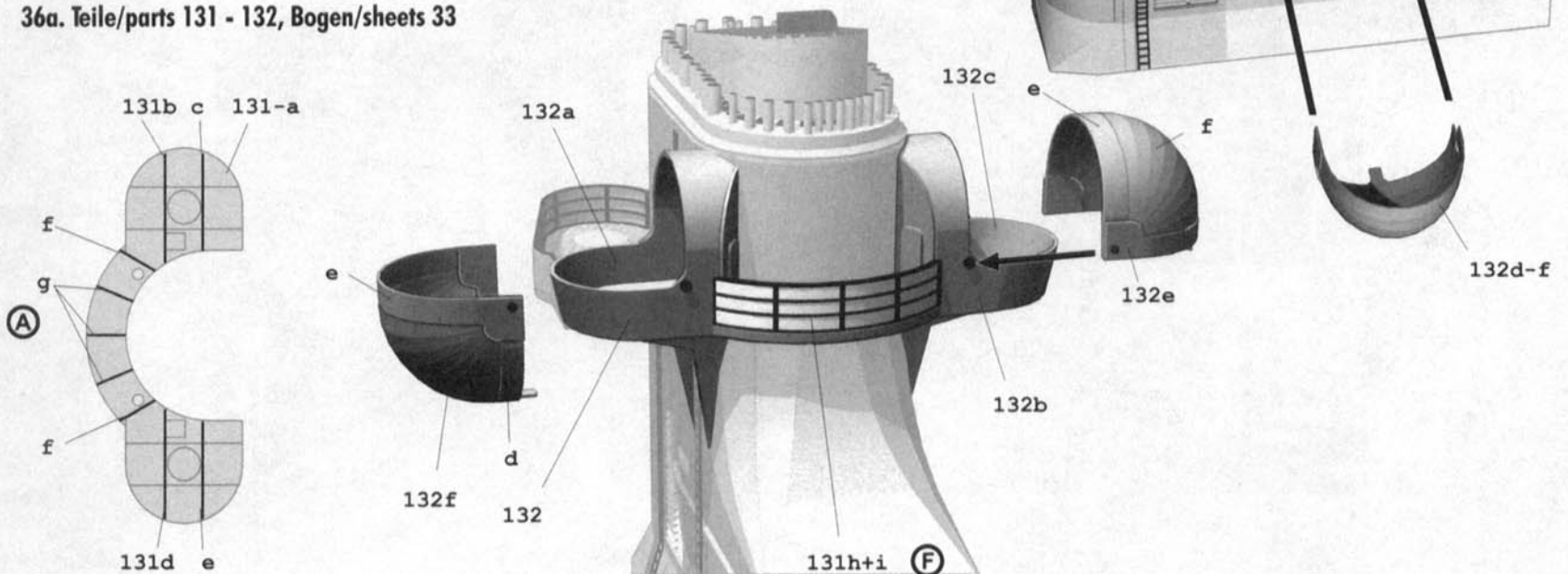

37. Teile/parts 133 - 134, Bogen/sheets 32 - 33

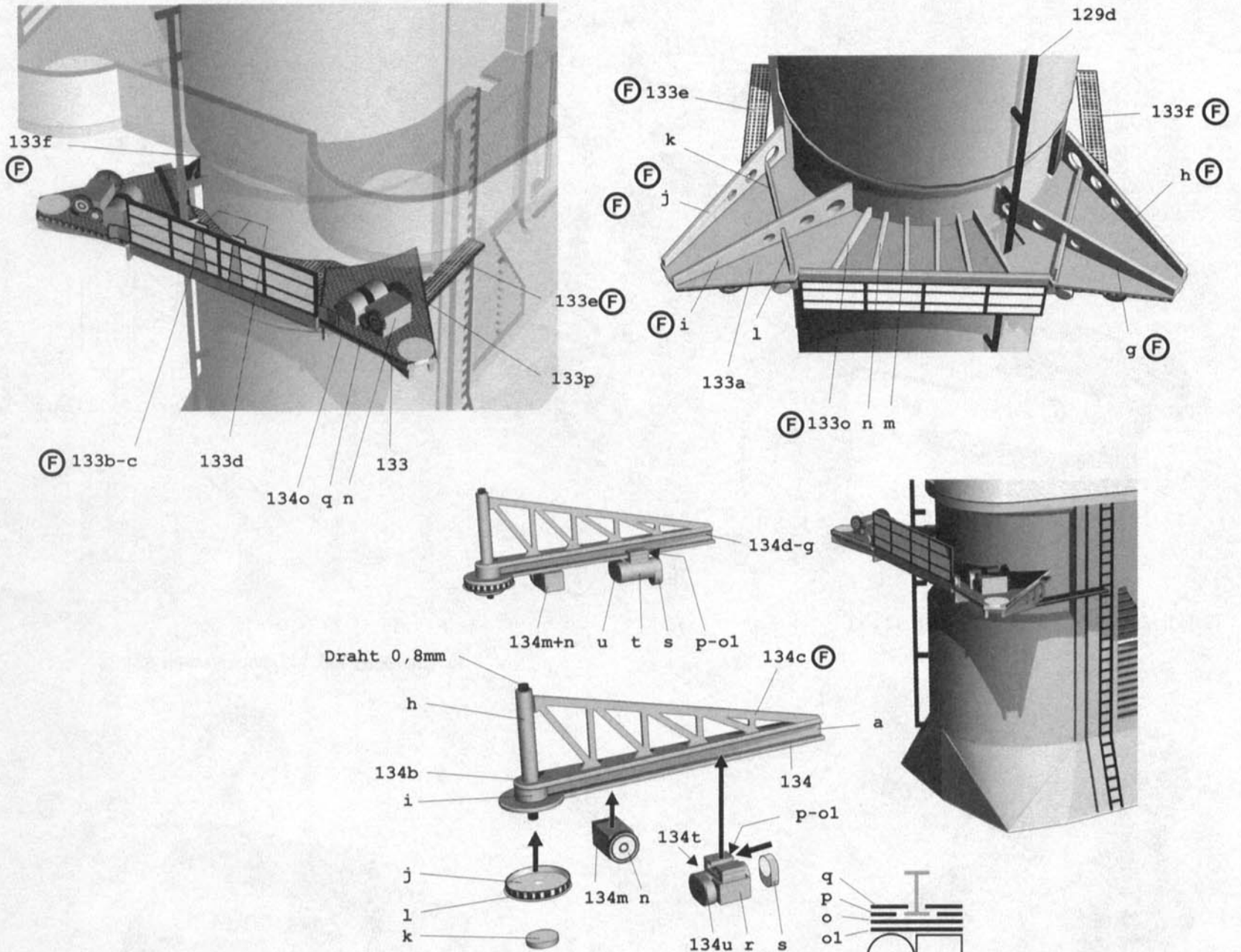

38. Teile/parts 135 - 136, 145d+e, Bogen/sheets 33 - 35

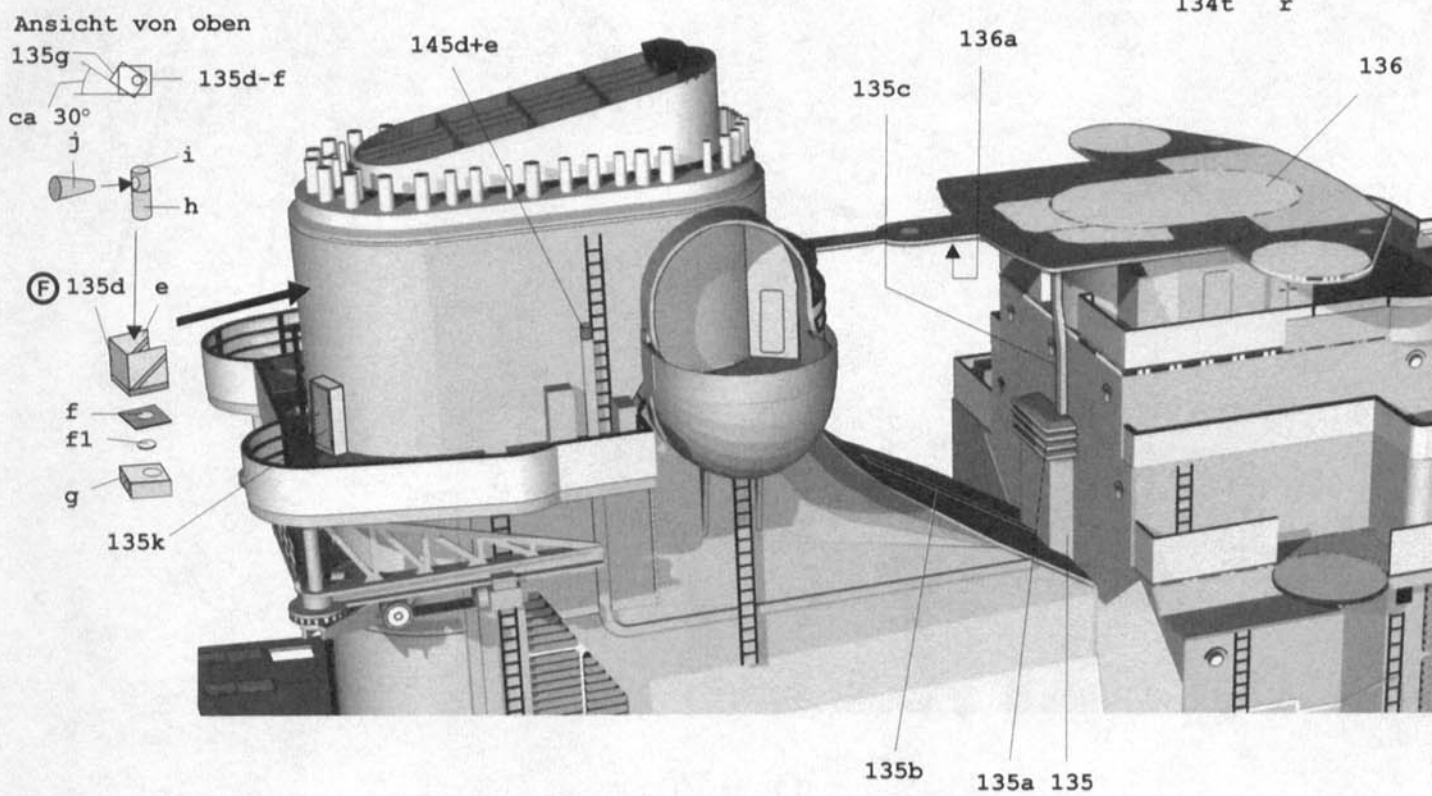

39. Teile/parts 136 - 141, Bogen/sheets 34 - 35

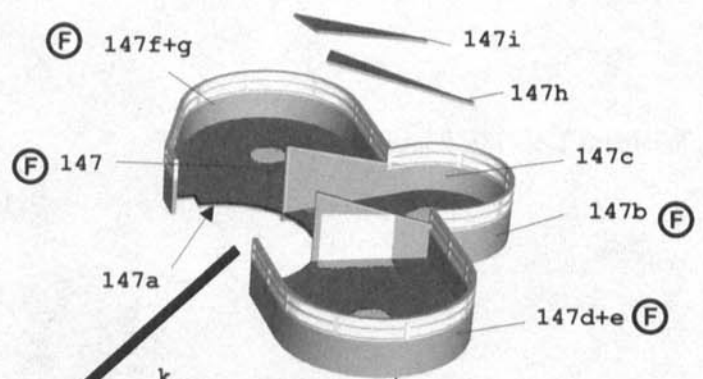
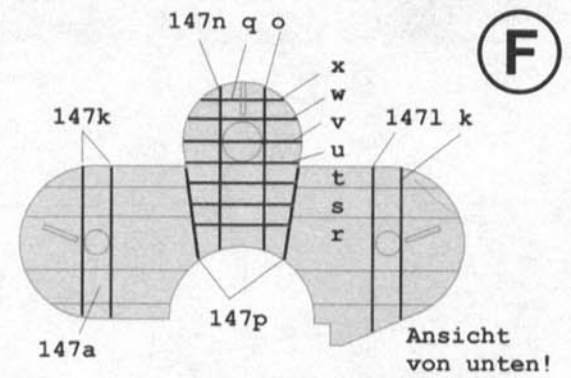
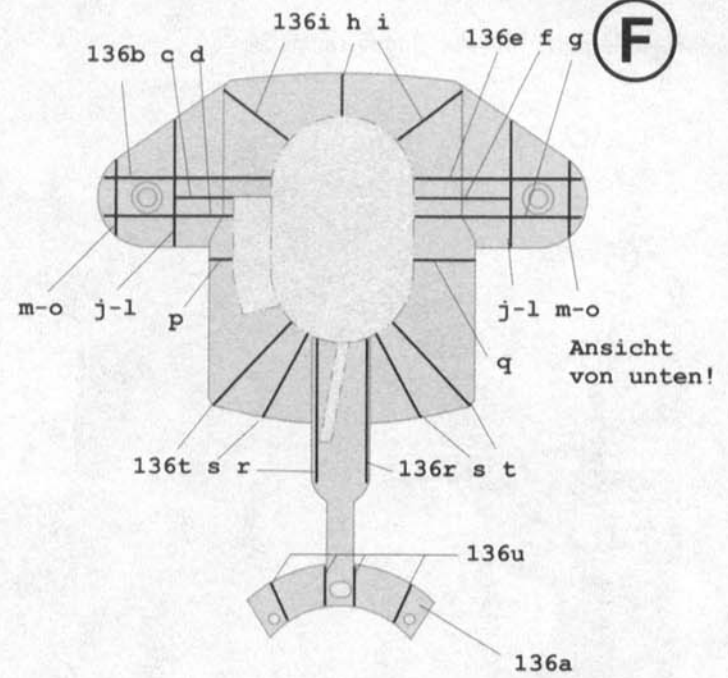
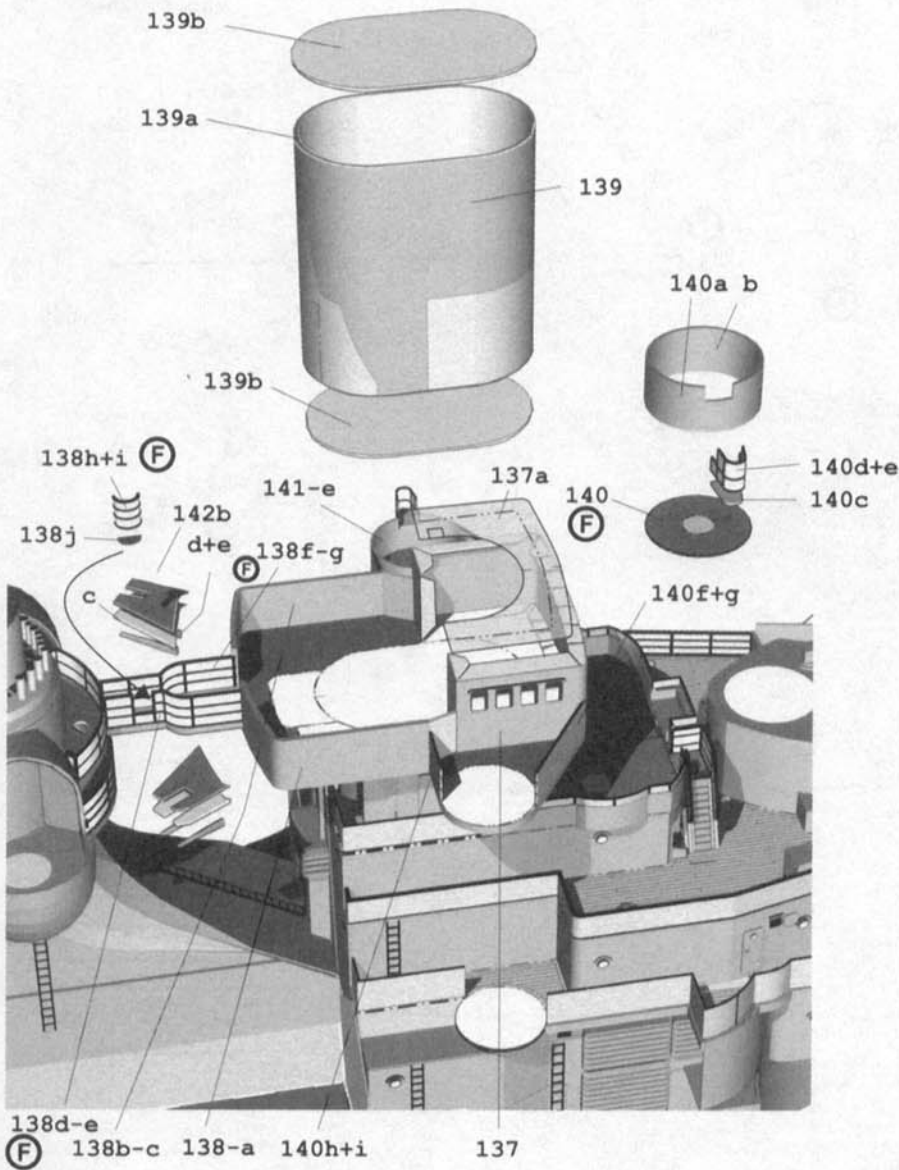

40. Teile/parts 143 - 144, 146 - 147
Bogen/sheets 33 - 35

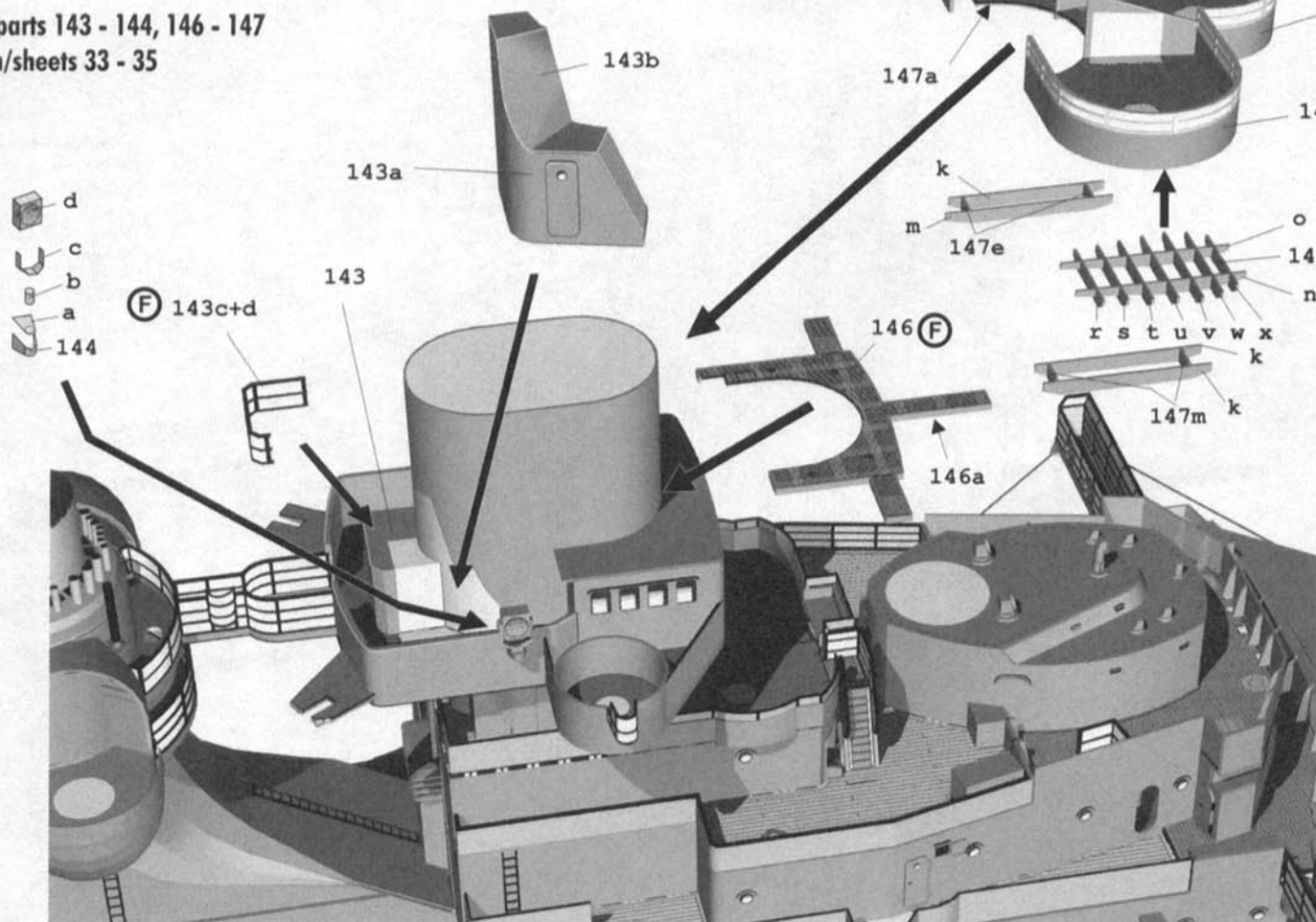

41. Teile/parts 142-152, Bogen/sheets 34 - 36

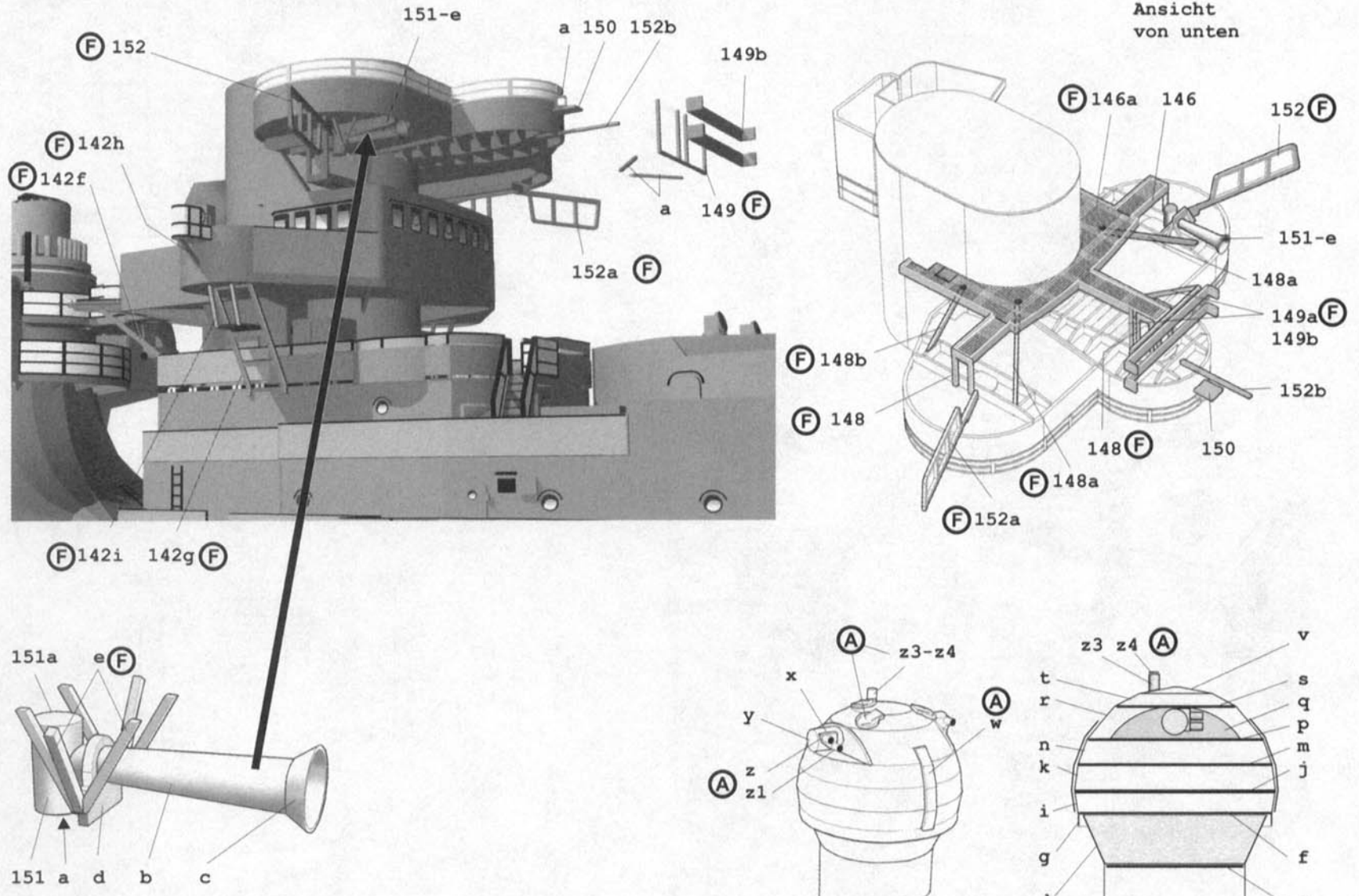

42. Teile/parts 135 - 136, Bogen/sheets 33 - 34

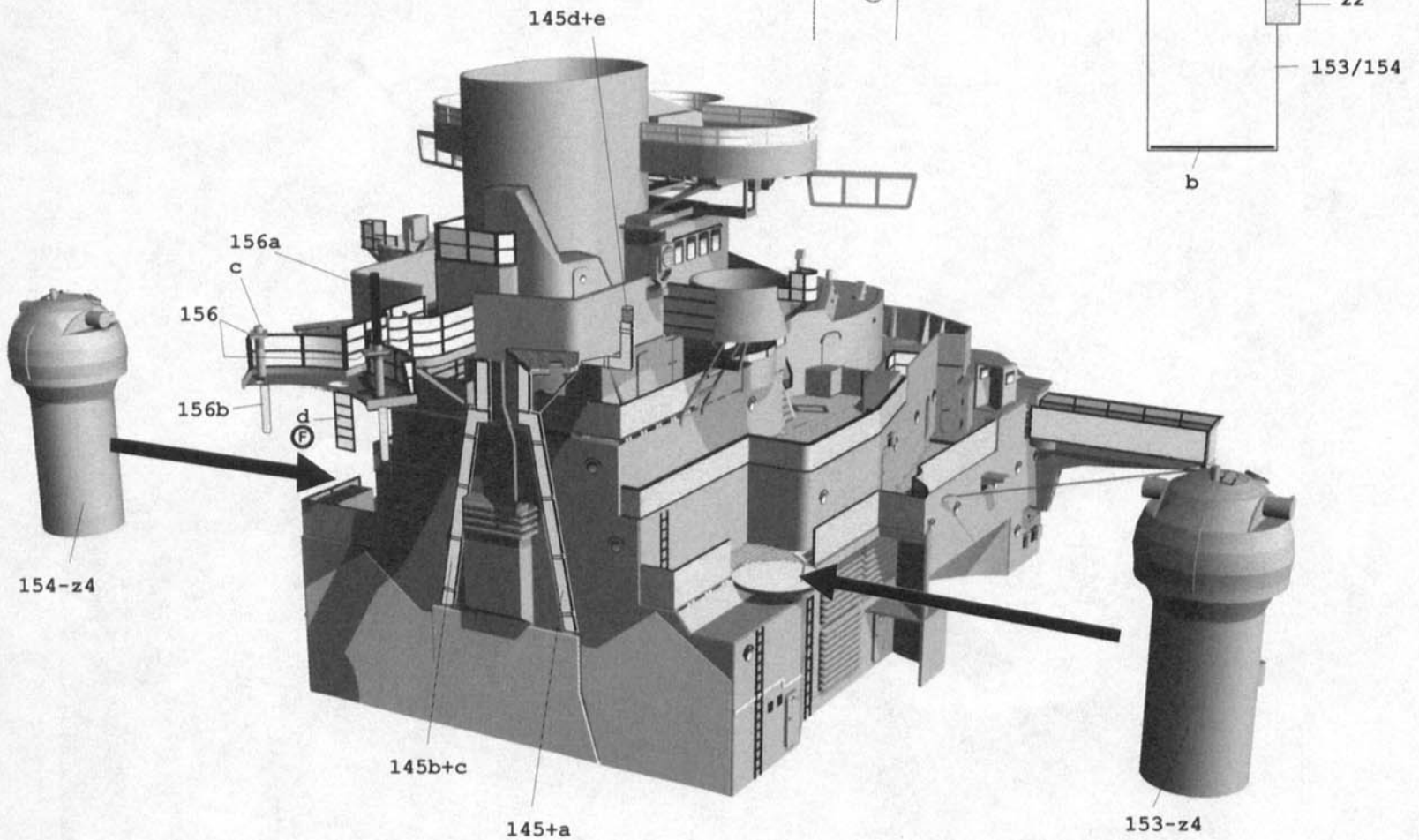

43. Teile/parts 155 - 162, Bogen/sheets 33, 36

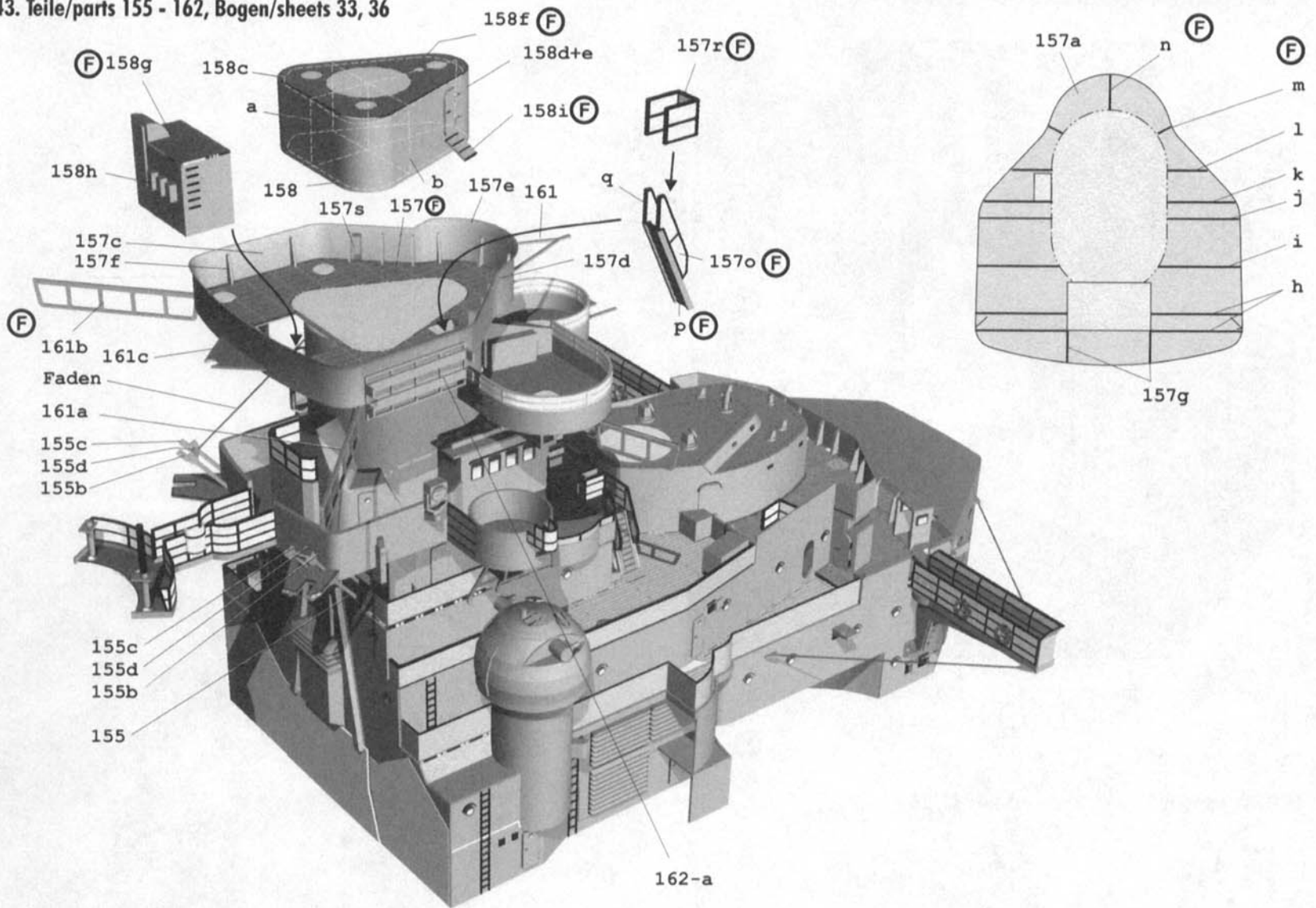

44. Teile/parts 159-160, 168 - 170, Bogen/sheets 33, 35-36

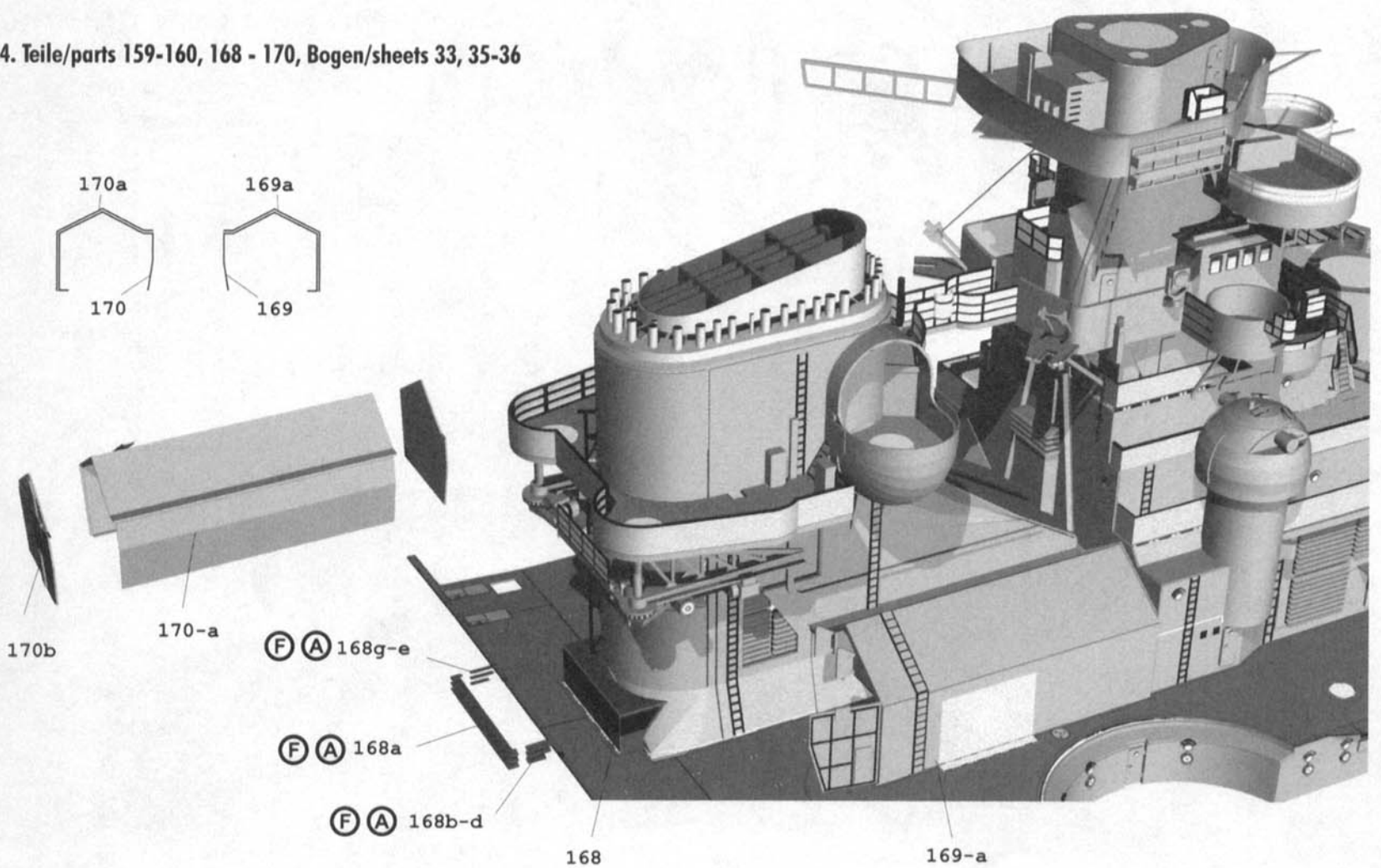

45. Teile/parts 168 - 172, Bogen/sheets 33, 35 - 36

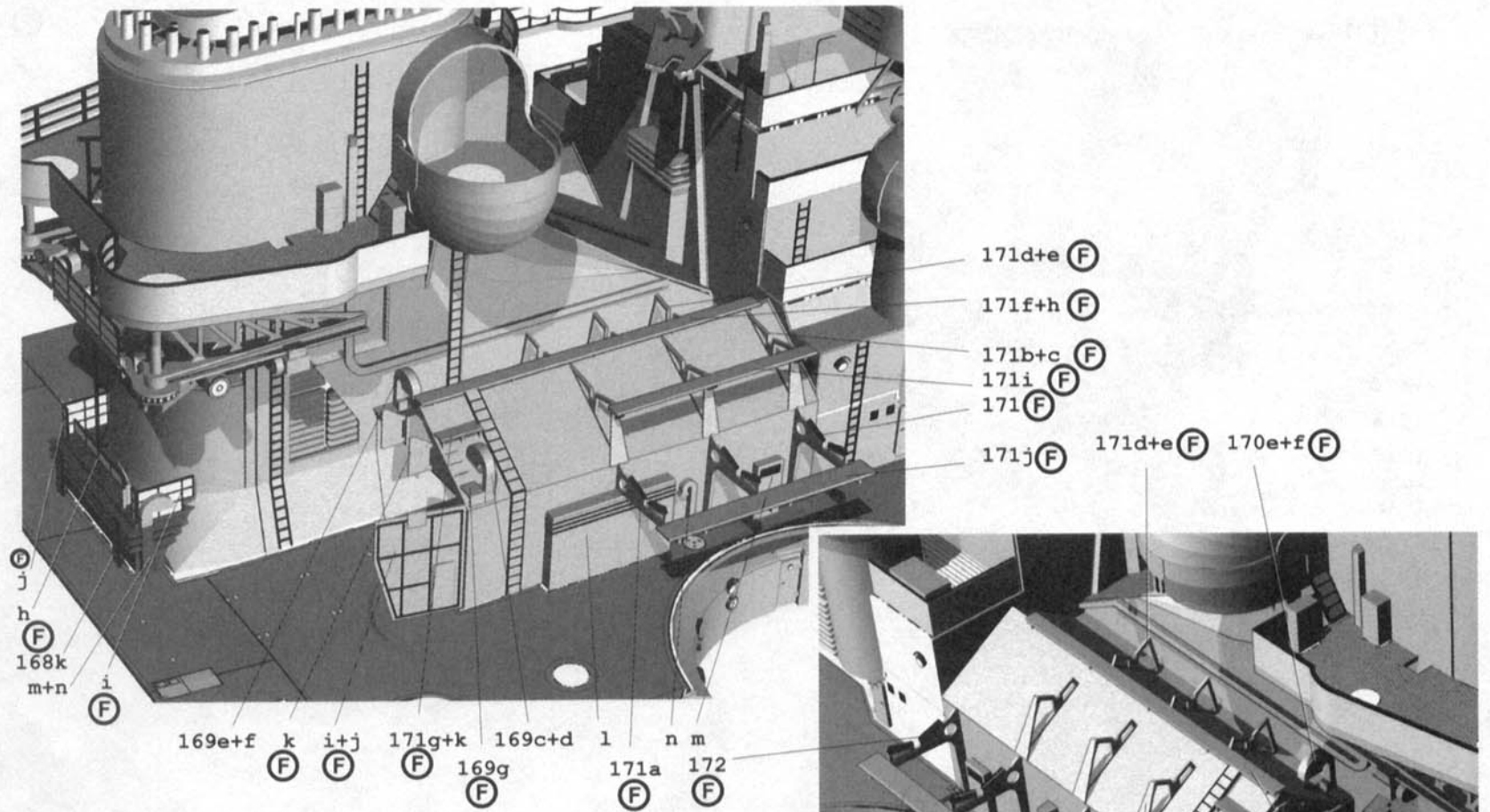

46. Teile/parts 163 - 167, Bogen/sheets 32, 36

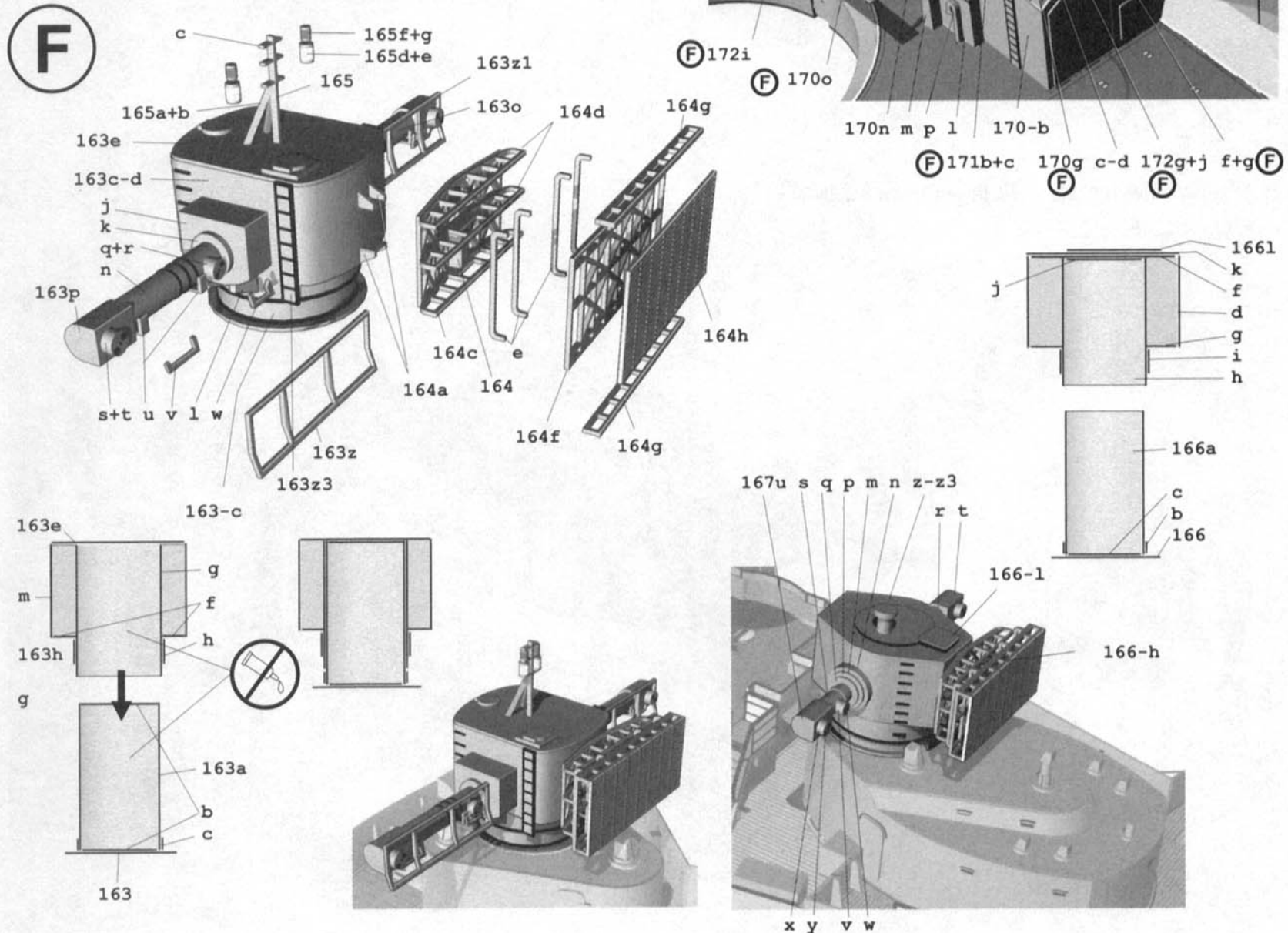

47. Teile/parts 173, 177, 179, Bogen/sheets 37

48. Teile/parts 174 - 178 Bogen/sheets 37

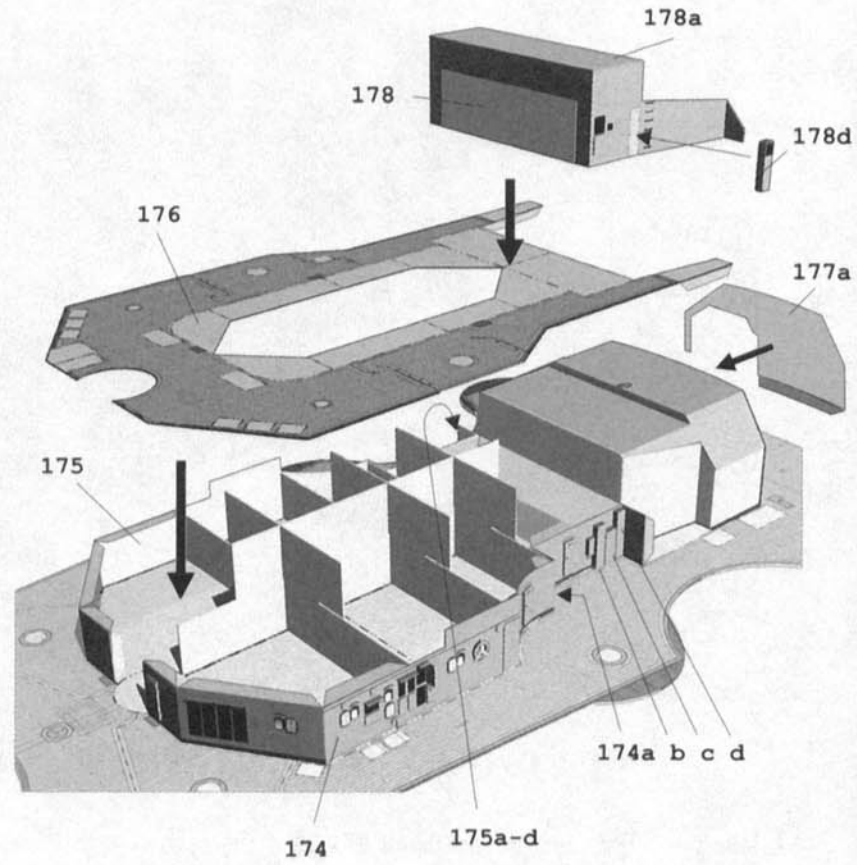
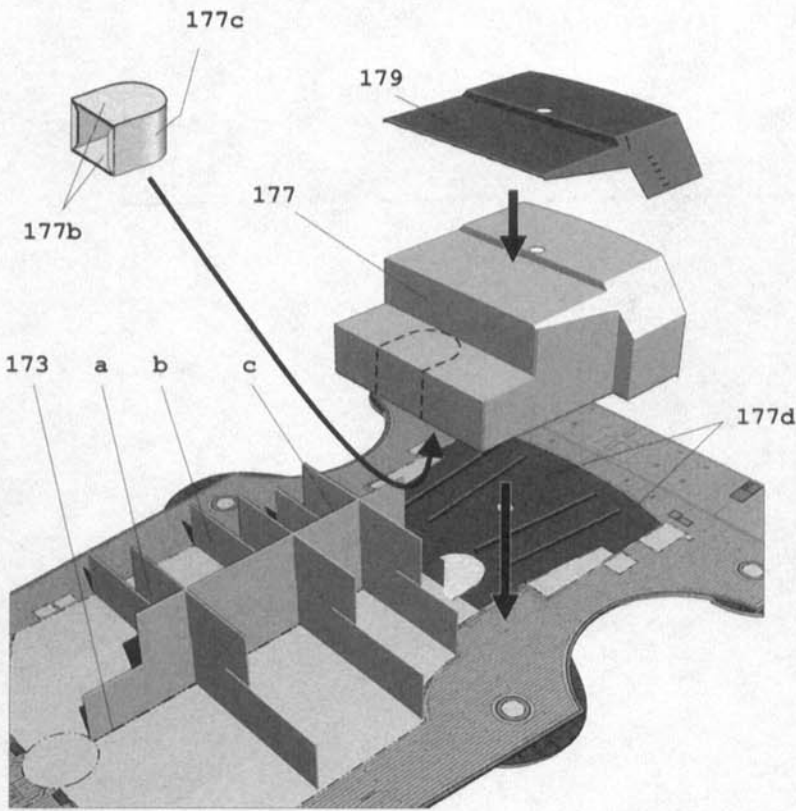

49. Teile/parts 163 - 167, Bogen/sheets 32, 36

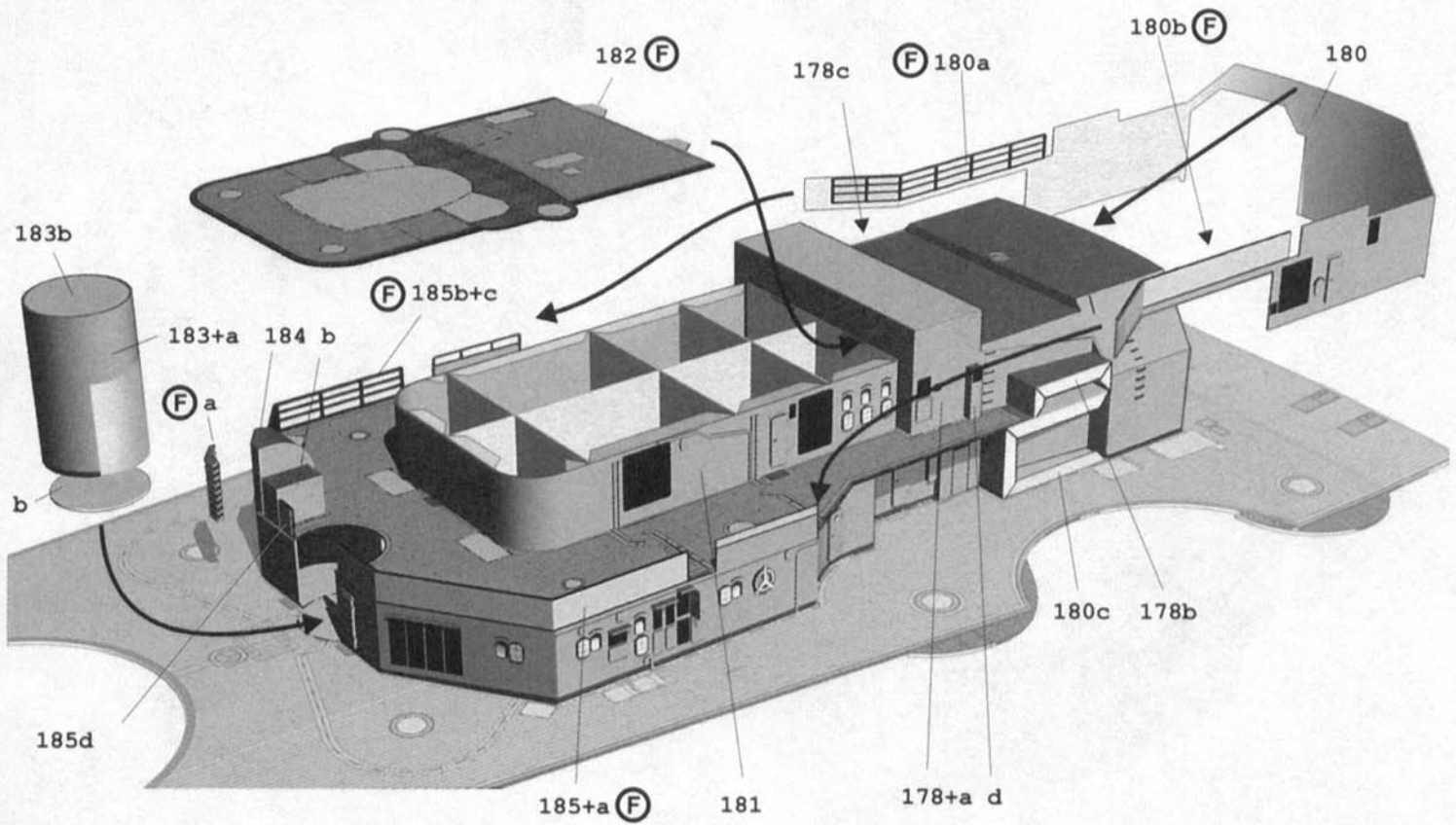

50. Teile/parts 186 - 188, Bogen/sheets 37

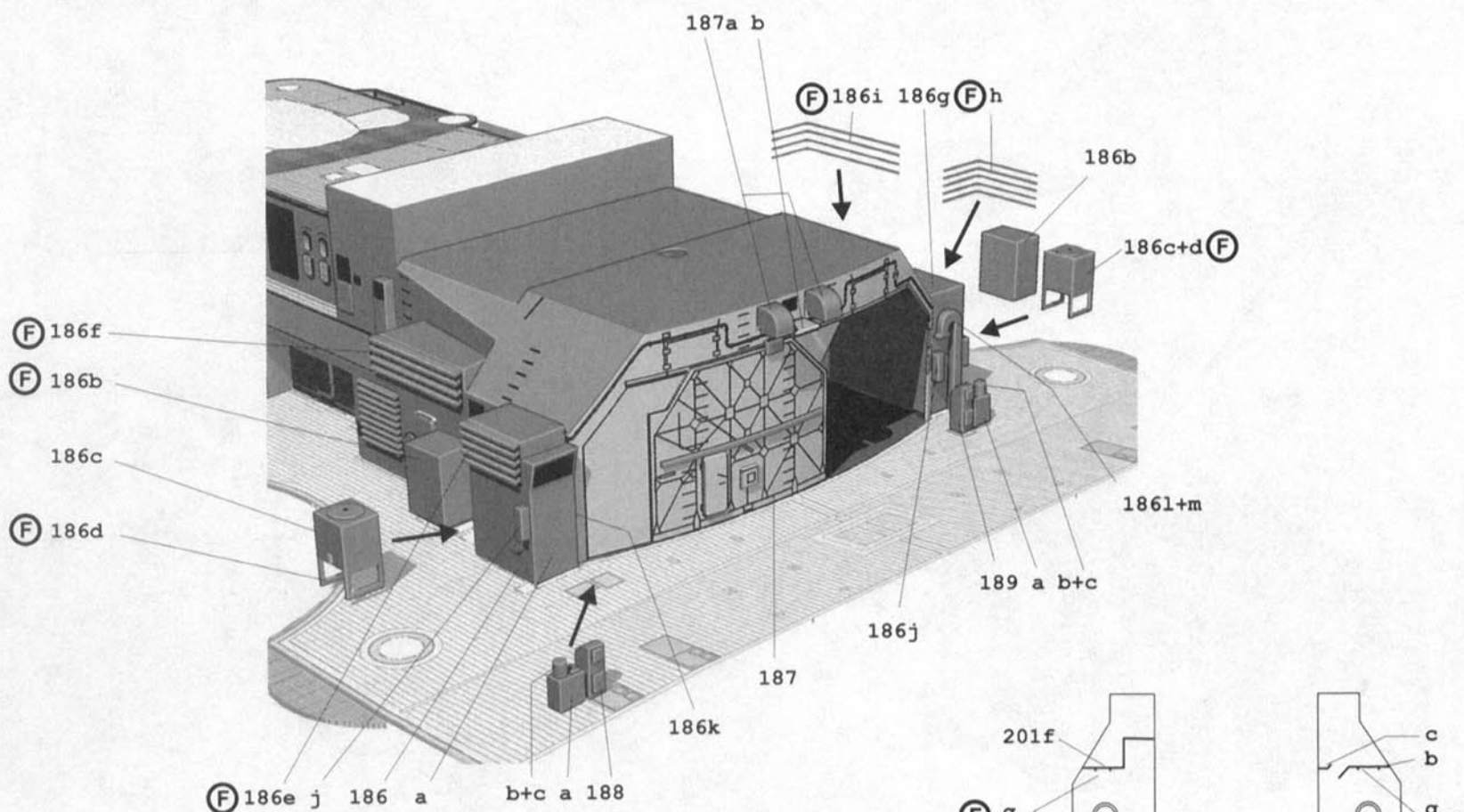

51. Teile/parts 190 - 200, Bogen/sheets 37 - 38

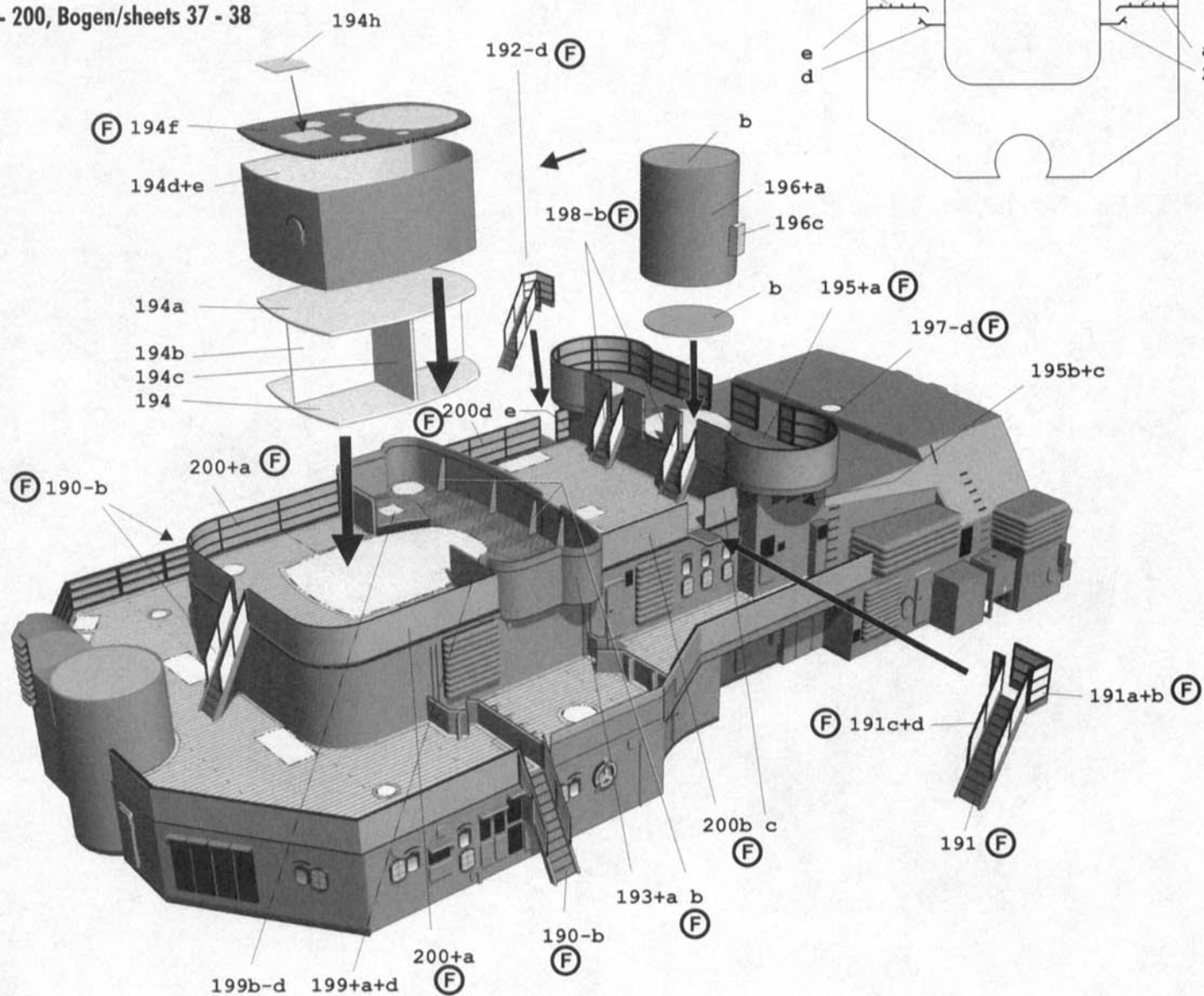

52. Teile/parts 201 - 210, Bogen/sheets 37 - 39

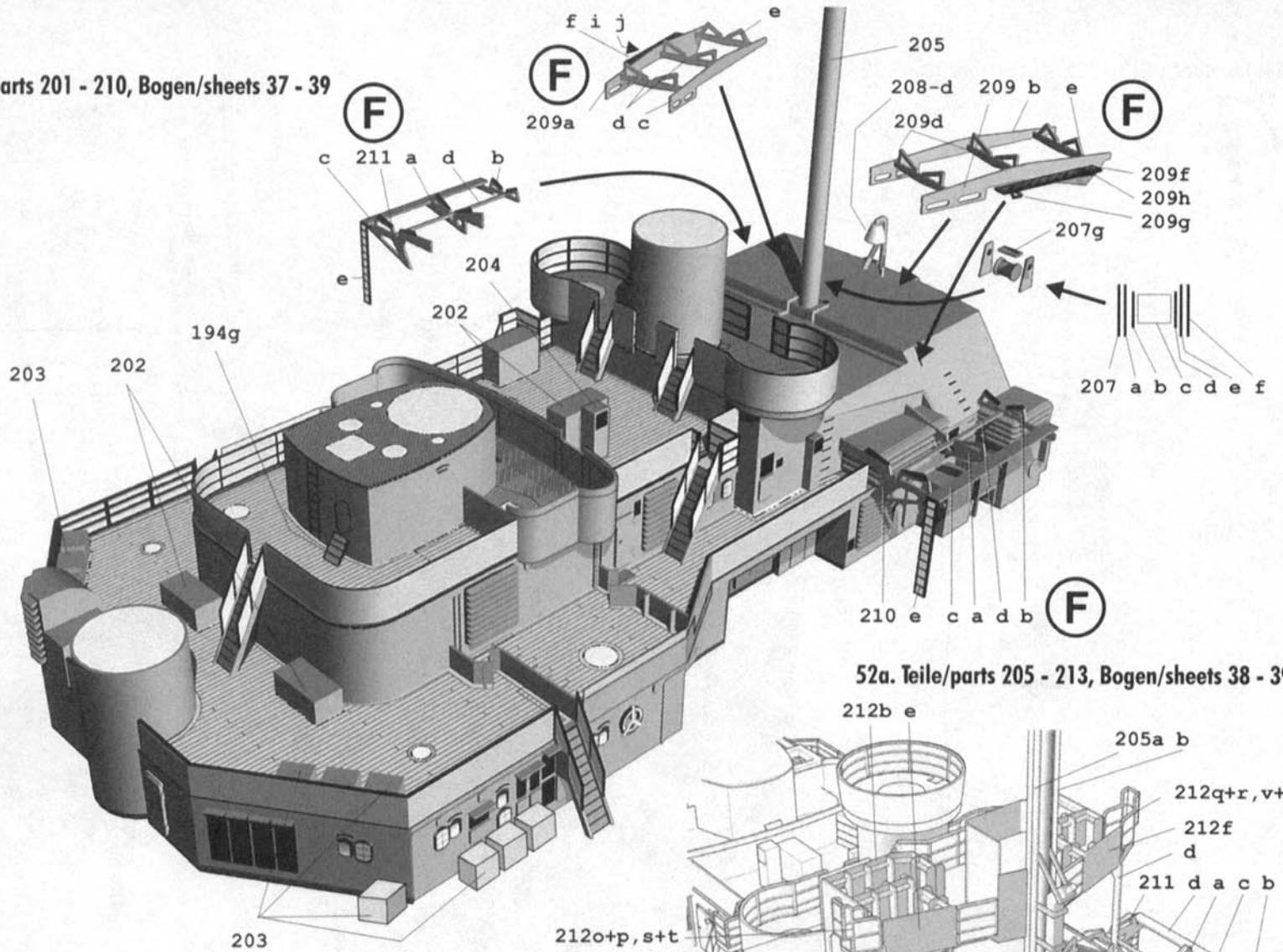

52a. Teile/parts 205 - 213, Bogen/sheets 38 - 39

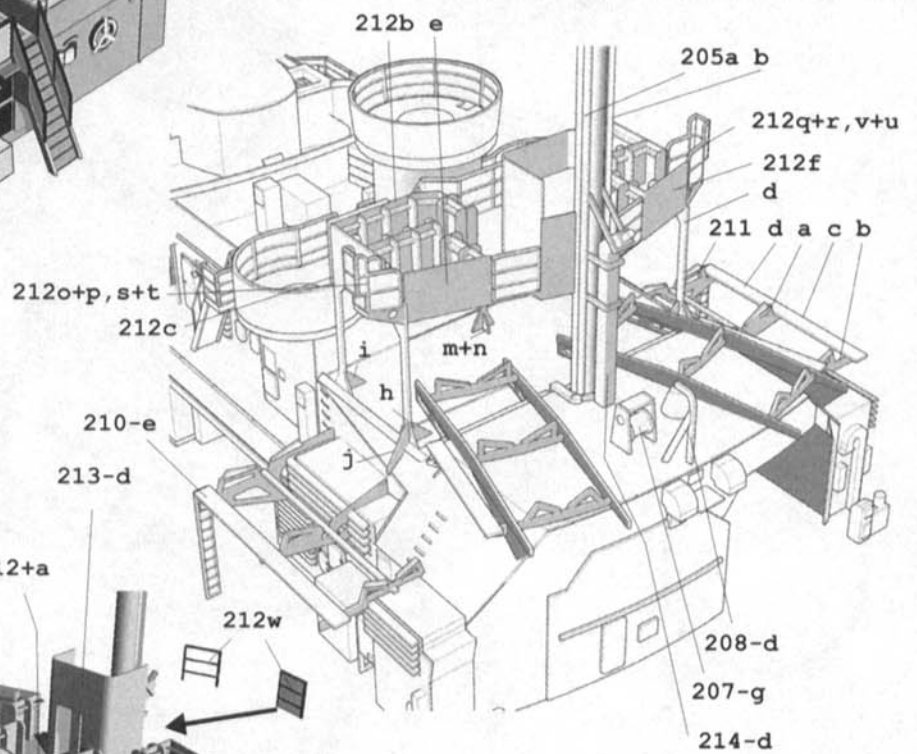

53. Teile/parts 212, 215-218 - 167, Bogen/sheets 39

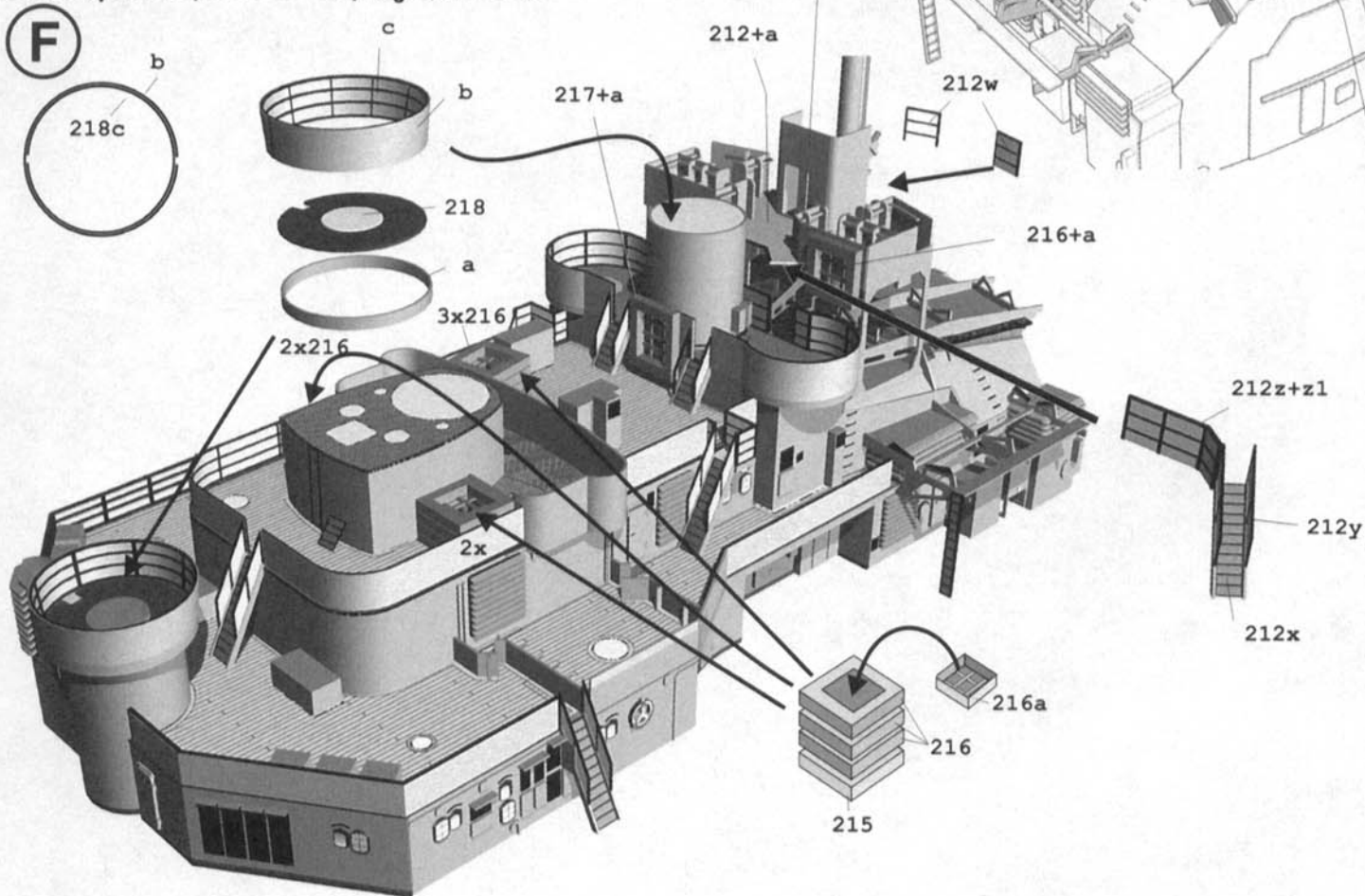

54. Teile/parts 218 - 225, Bogen/sheets 38 - 39

F

163-164
Zusammenbau siehe Bauschritt 46

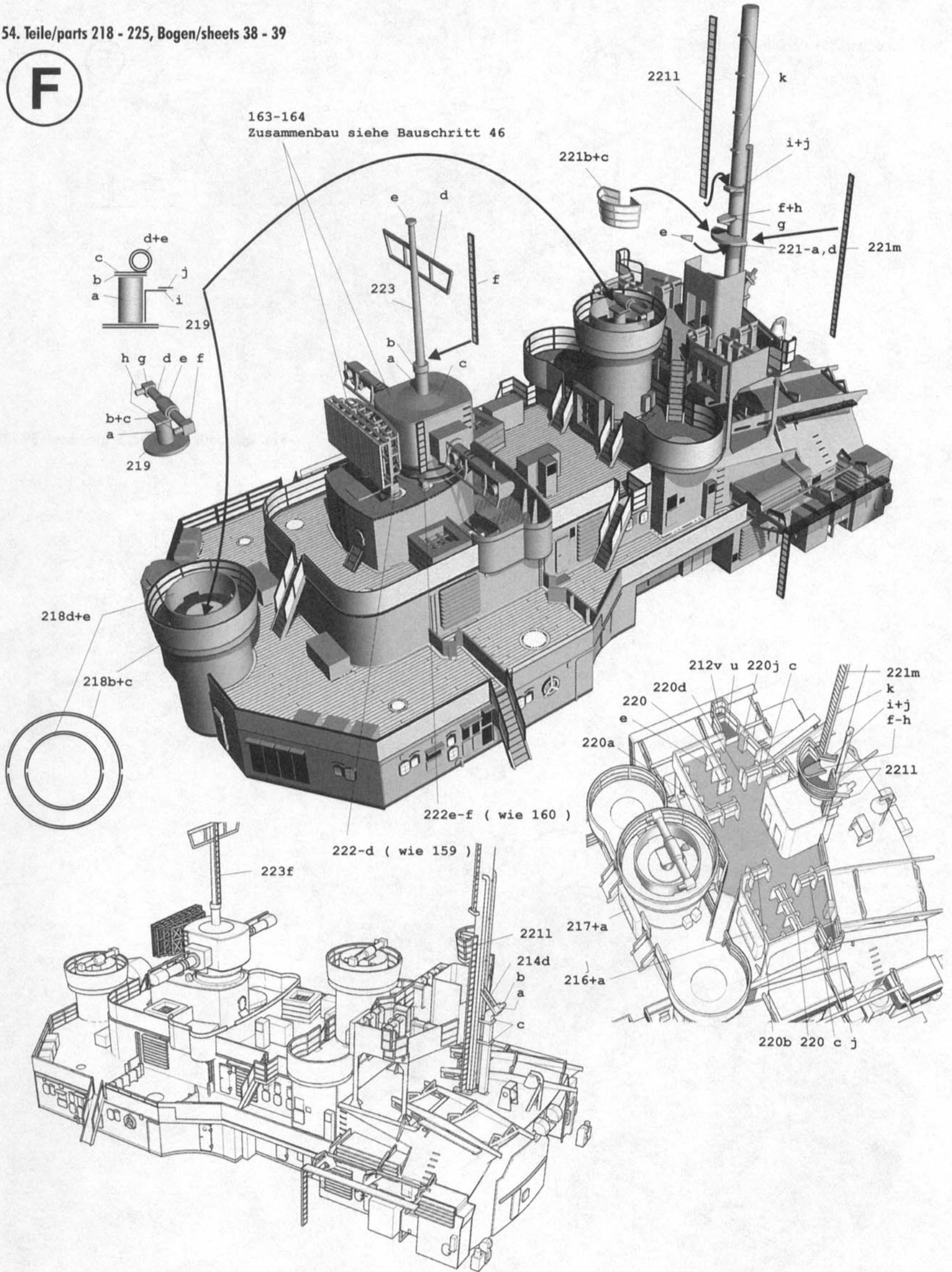

55. Teile/parts 236 - 237, Bogen/sheets 41

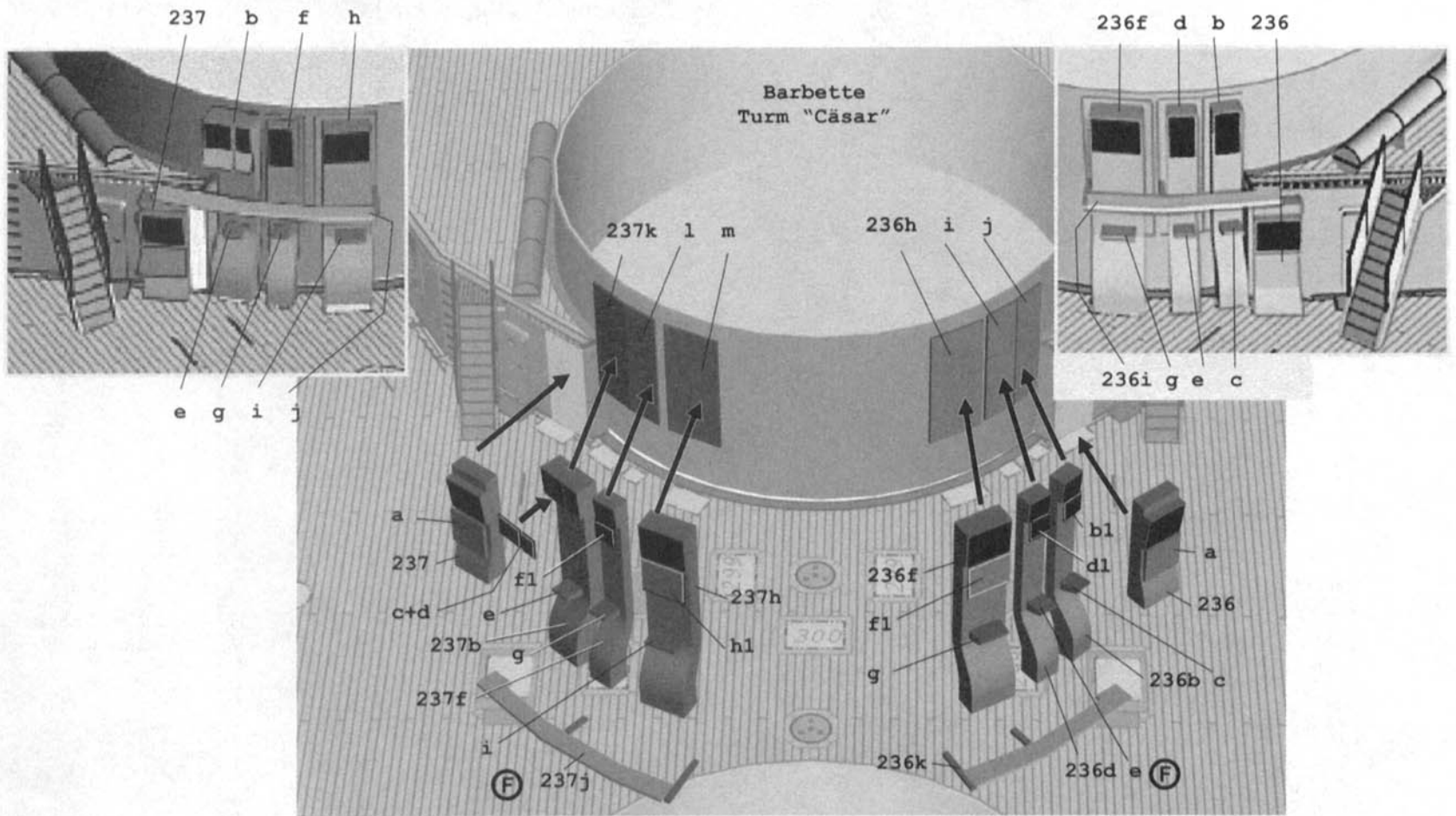

56. Teile/parts 238 - 239, Bogen/sheets 41

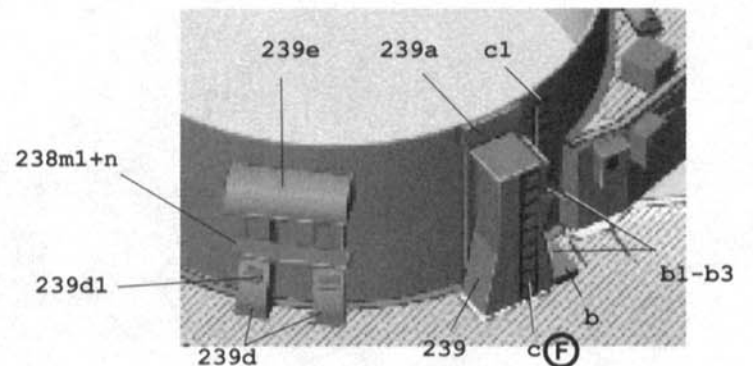
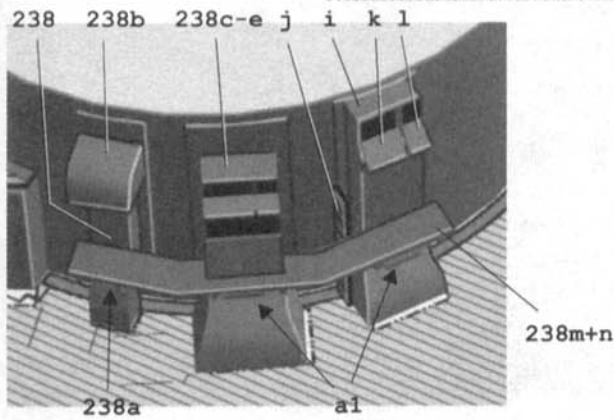
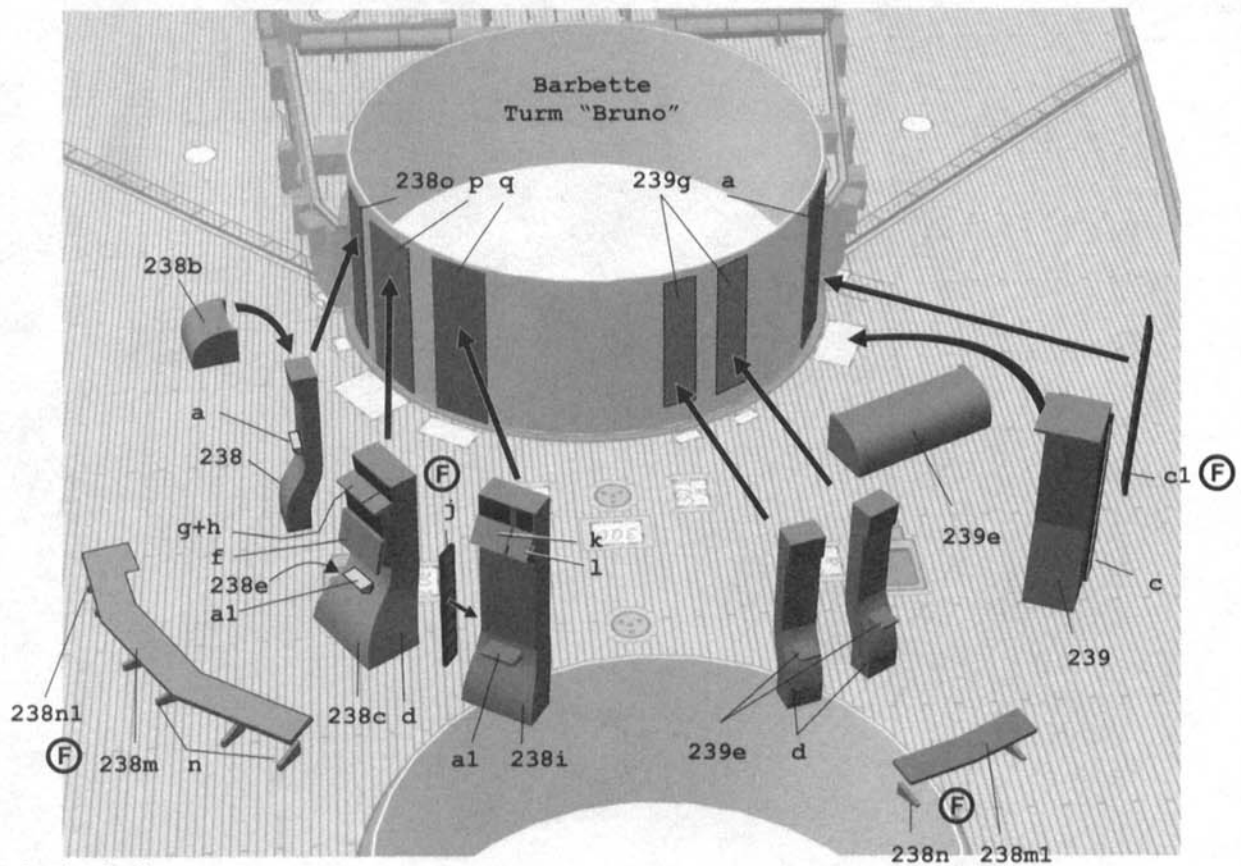

57. Teile/parts 240 - 242, Bogen/sheets 41

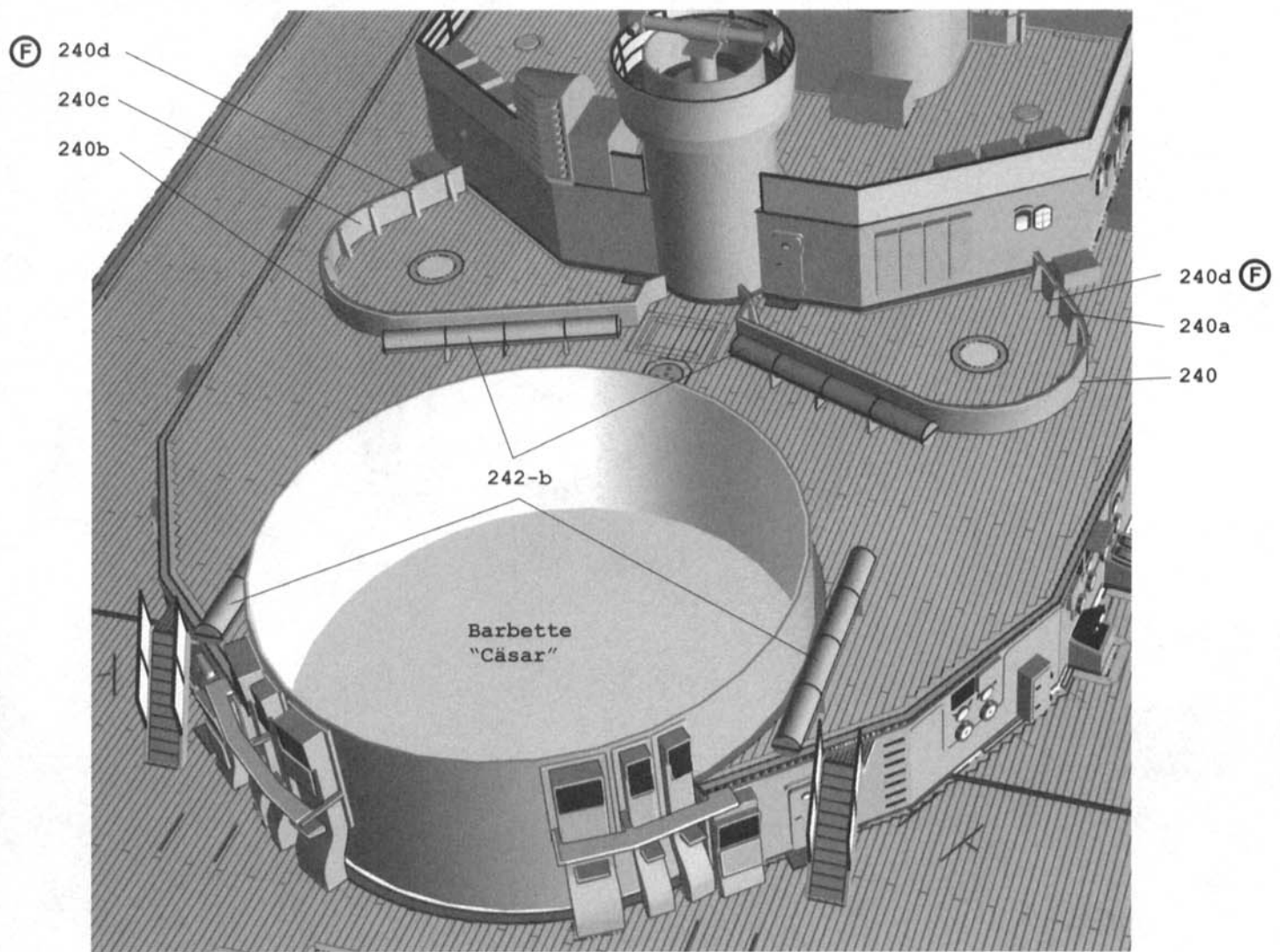
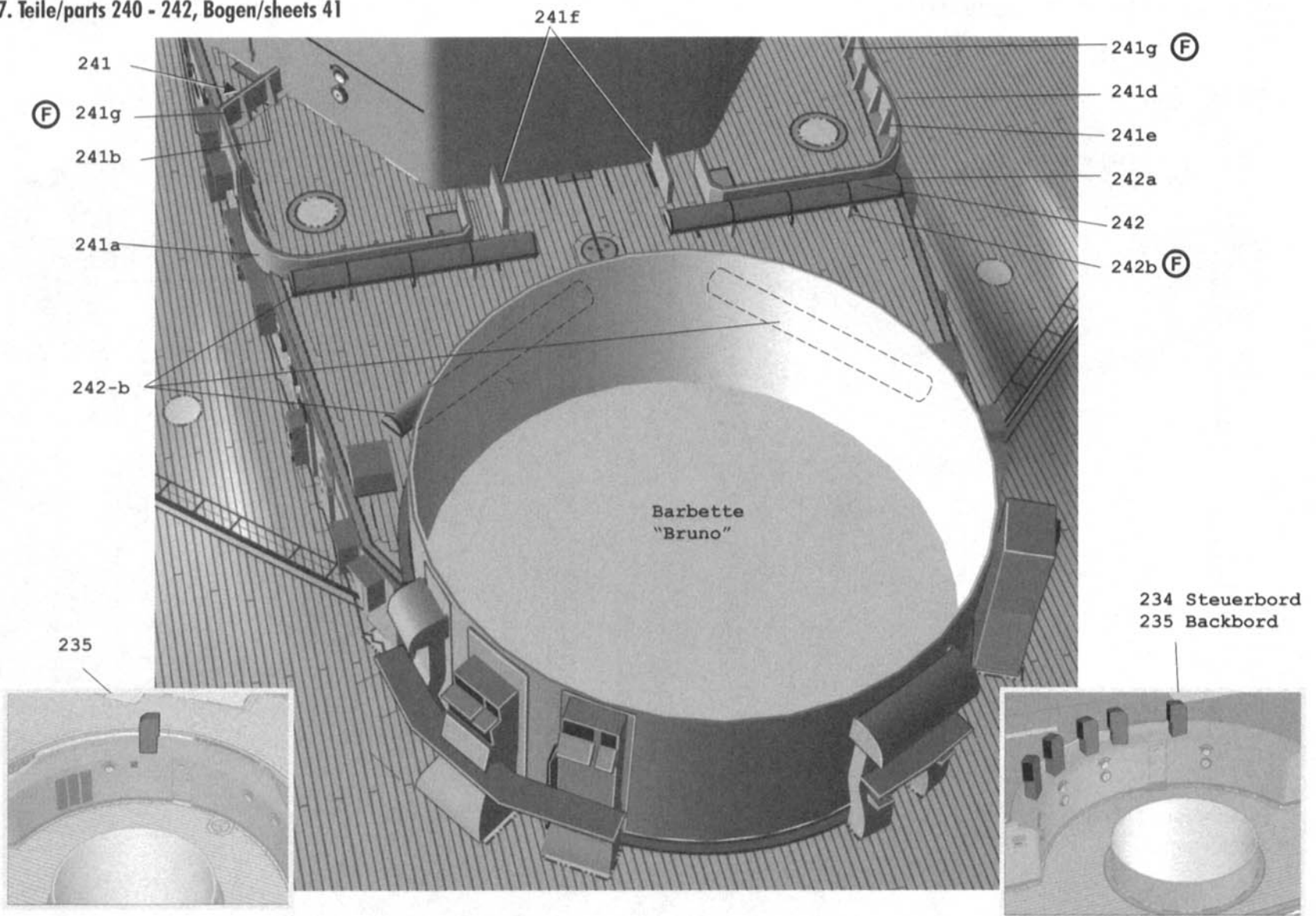

58. Teile/parts 243-250, Bogen/sheets 42-45

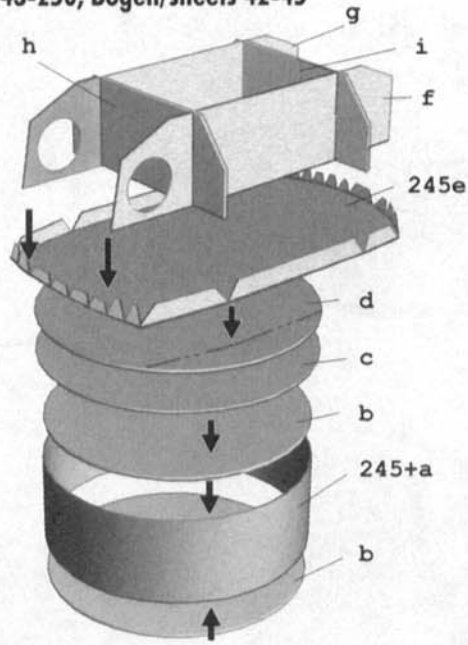

59. Teile/parts 245, Bogen/sheets 43

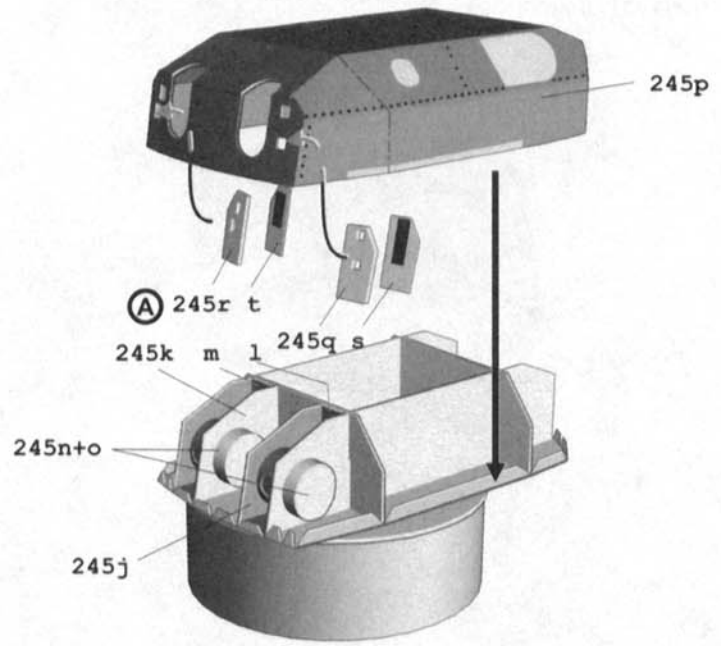

60. Teile/parts 245 - 246, Bogen/sheets 43

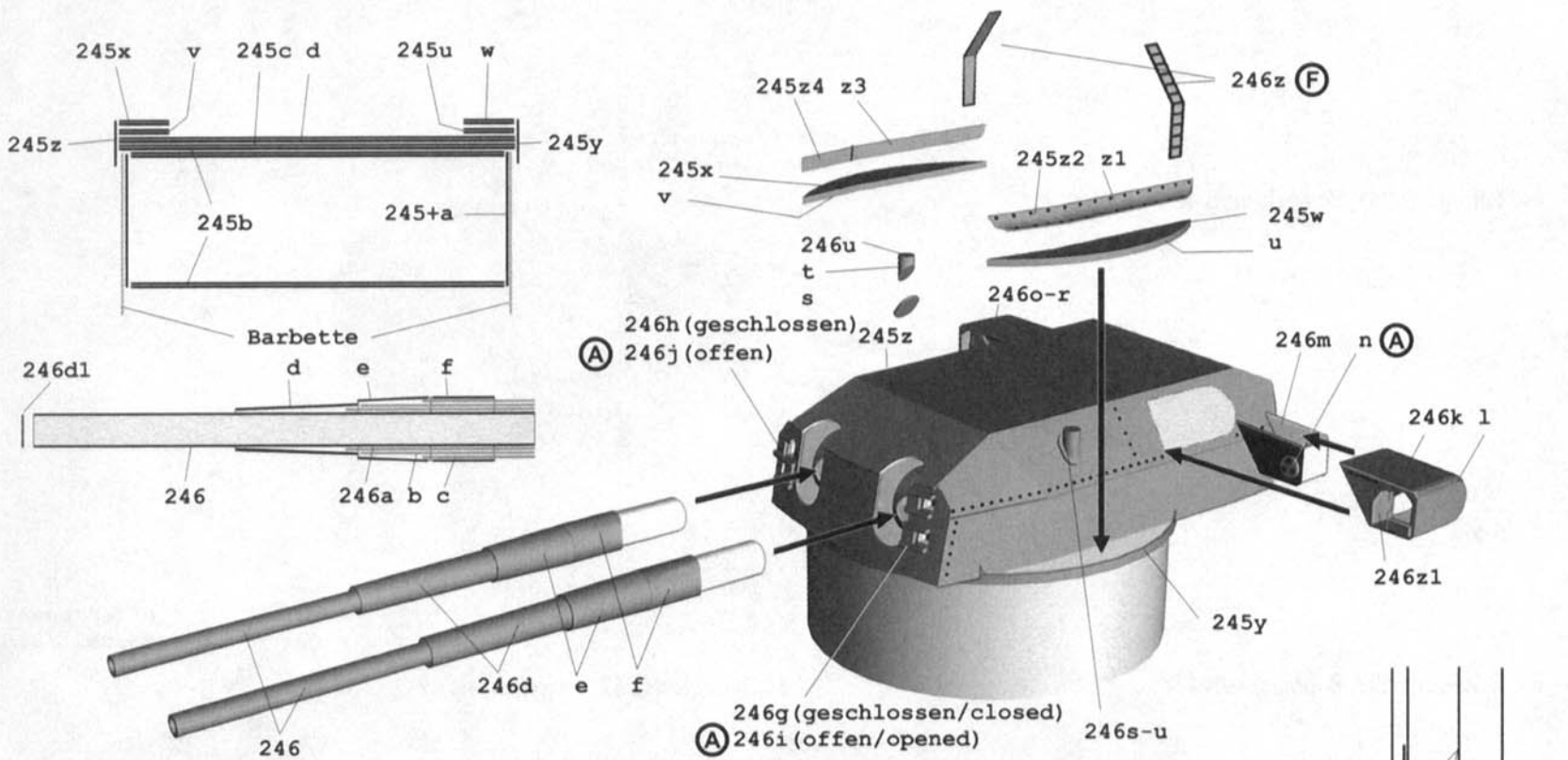

61. Teile/parts 246, Bogen/sheets 42

Nur/only an Turm "Anton": 2441+m

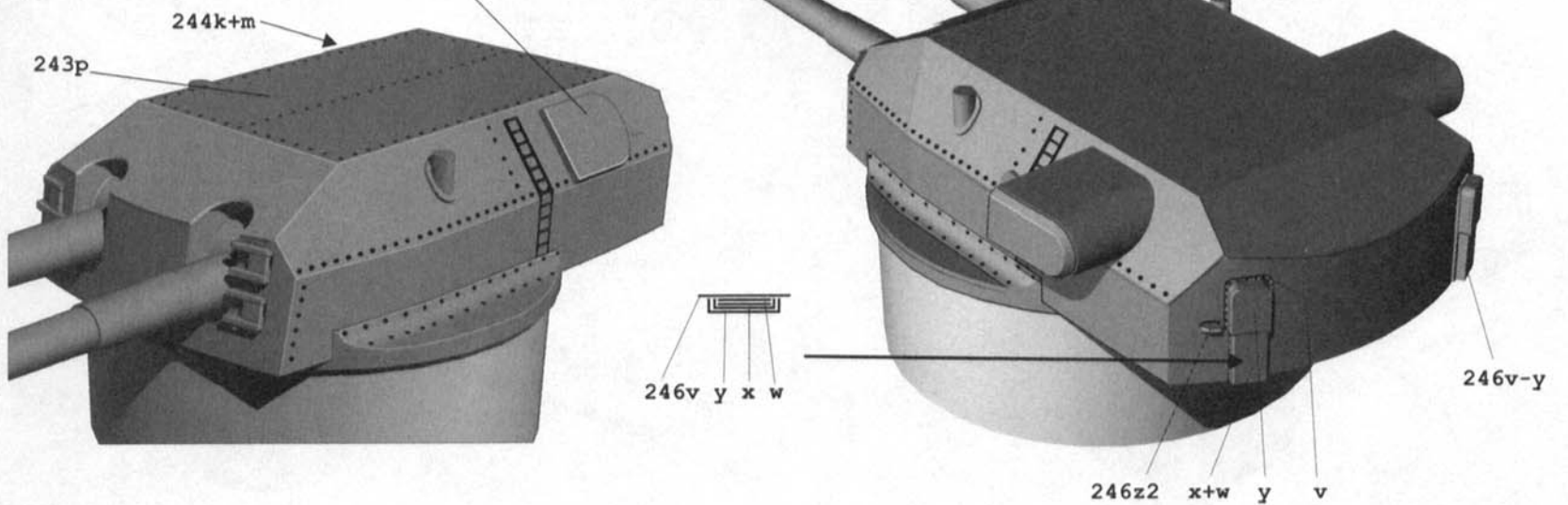

62. Teile/parts 251, Bogen/sheets 46

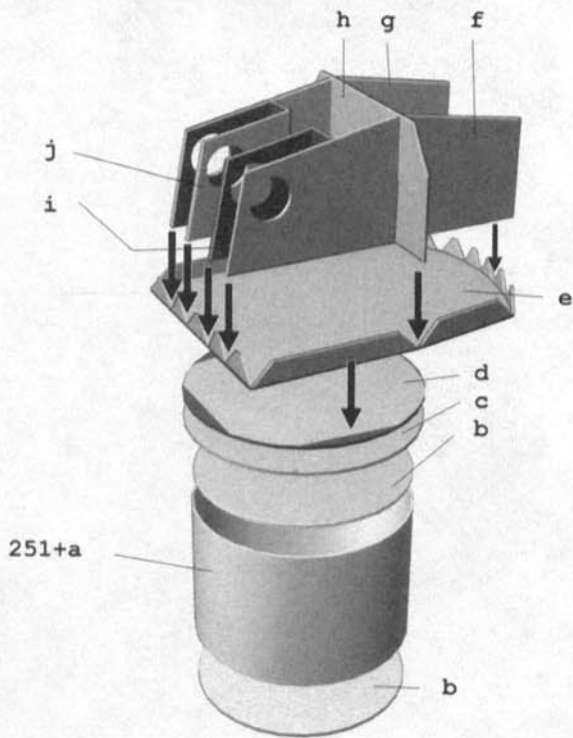

63. Teile/parts 251, Bogen/sheets 46

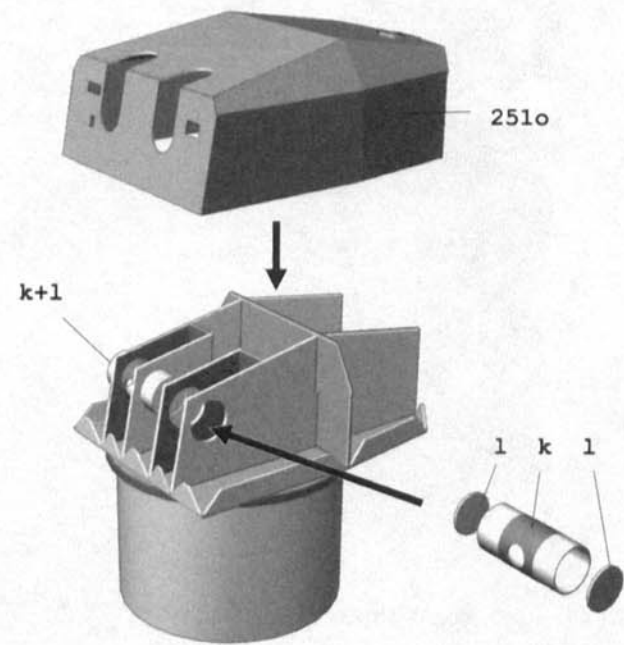

64. Teile/parts 251, Bogen/sheets 46

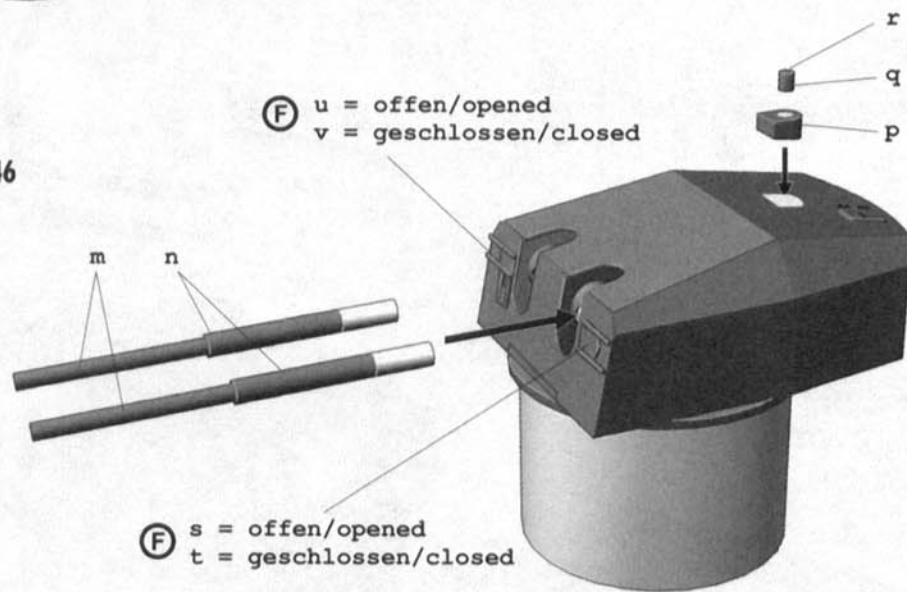

65. Teile/parts 252, Bogen/sheets 47

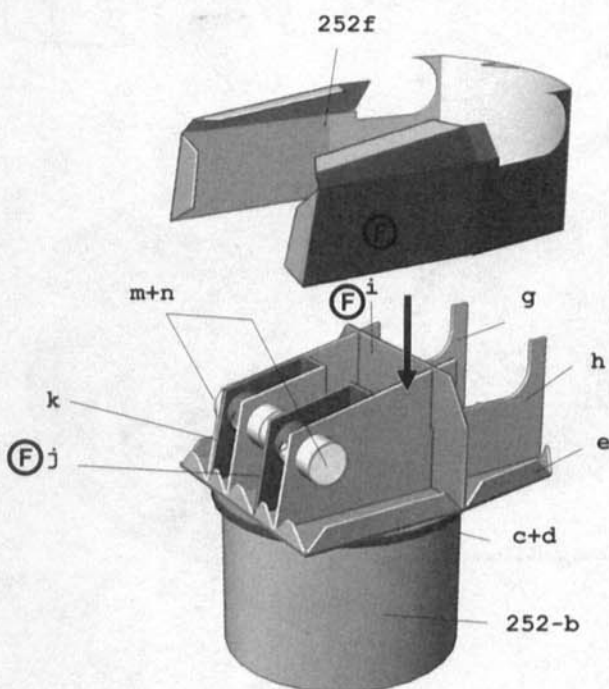

66. Teile/parts 252, Bogen/sheets 47

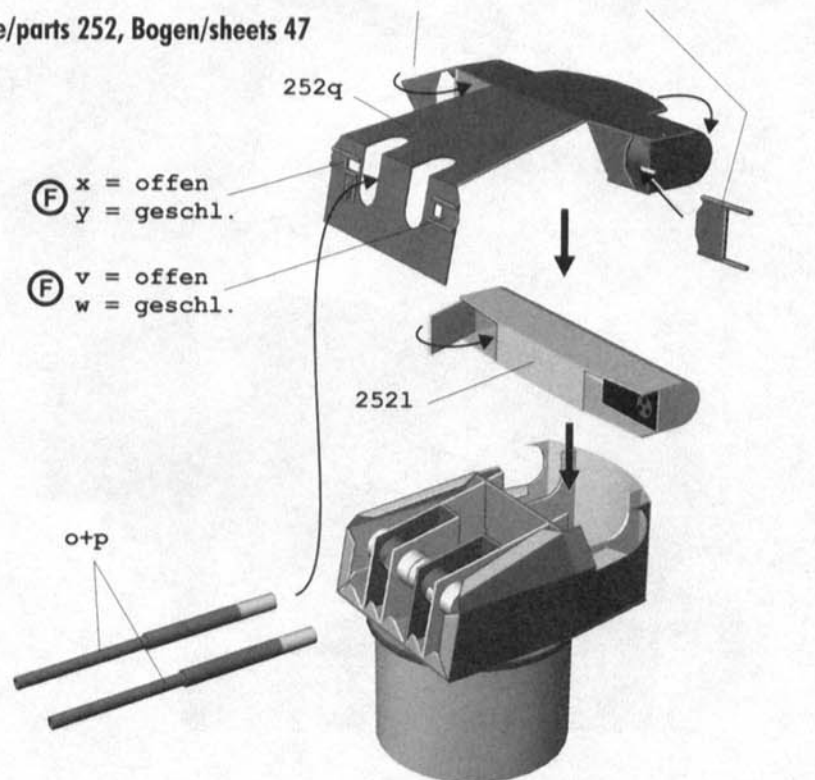

67. Teile/parts 253, Bogen/sheets 47-48

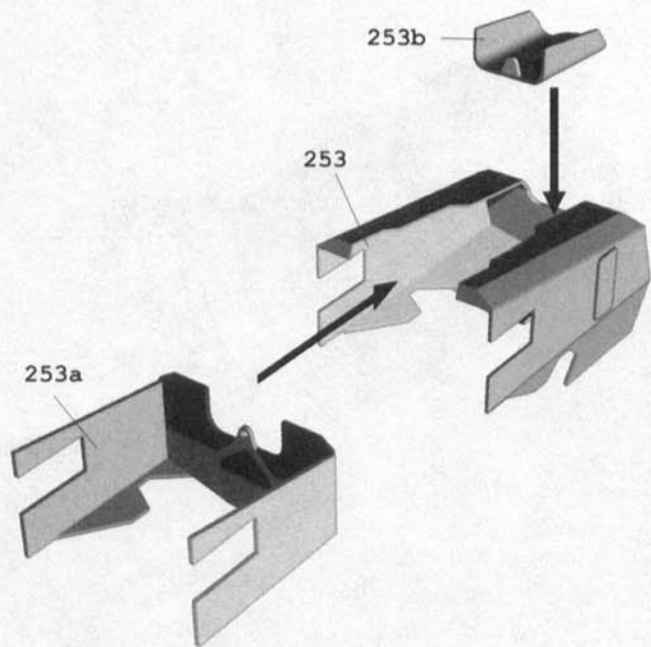

68. Teile/parts 253, Bogen/sheets 47-48

Draht/wire
7,5mm x 0,5mm ø

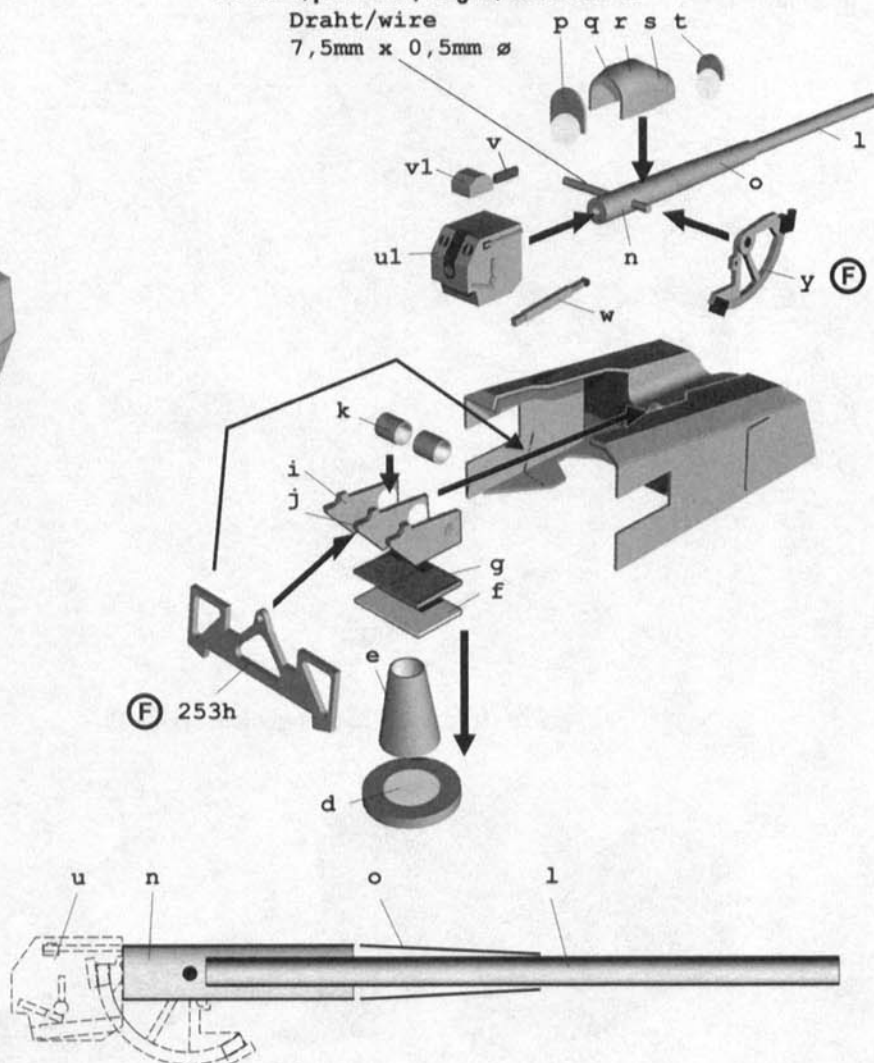

69. Teile/parts 253, Bogen/sheets 47-48

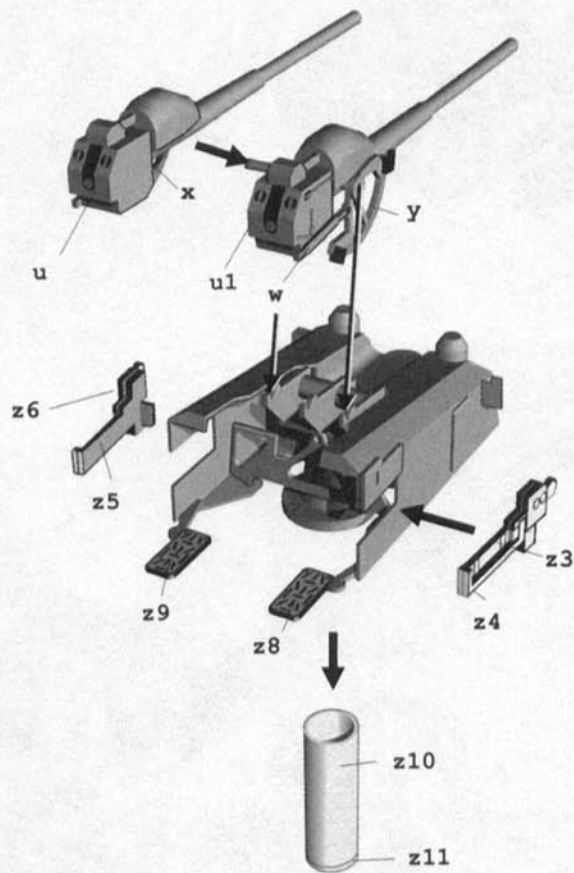

70. Teile/parts 253, Bogen/sheets 47-48

253u

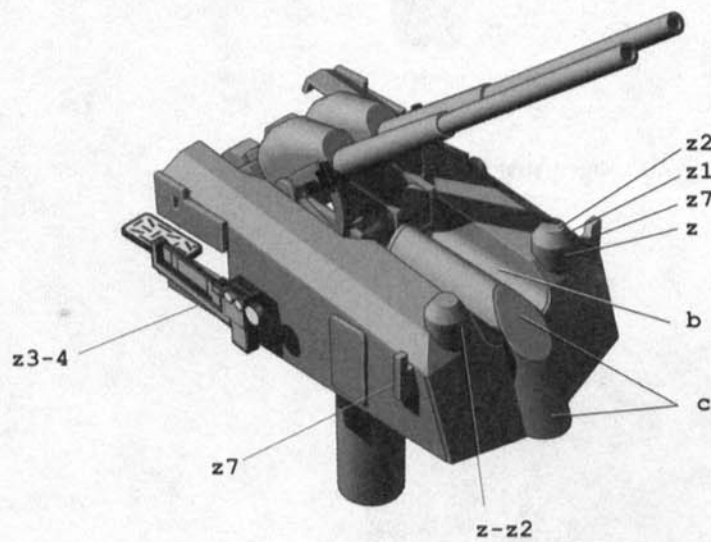

71. Teile/parts 254, Bogen/sheets 48-49

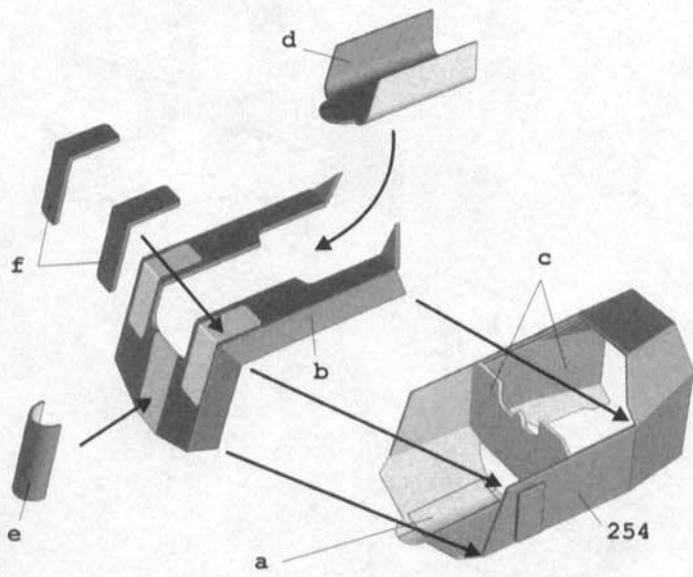

72a. Teile/parts 254, Bogen/sheets 48-49

72. Teile/parts 254, Bogen/sheets 48-49

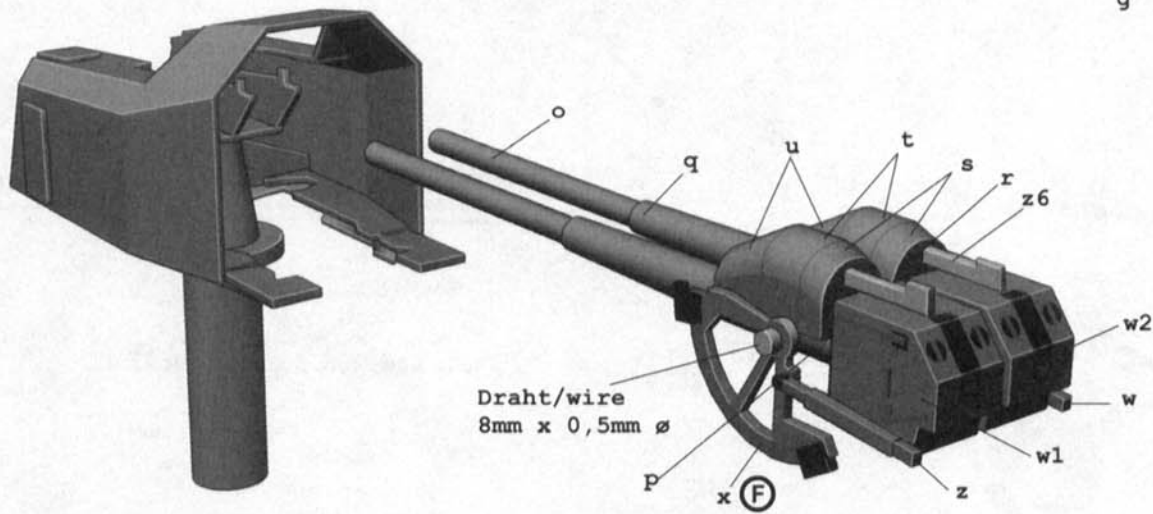
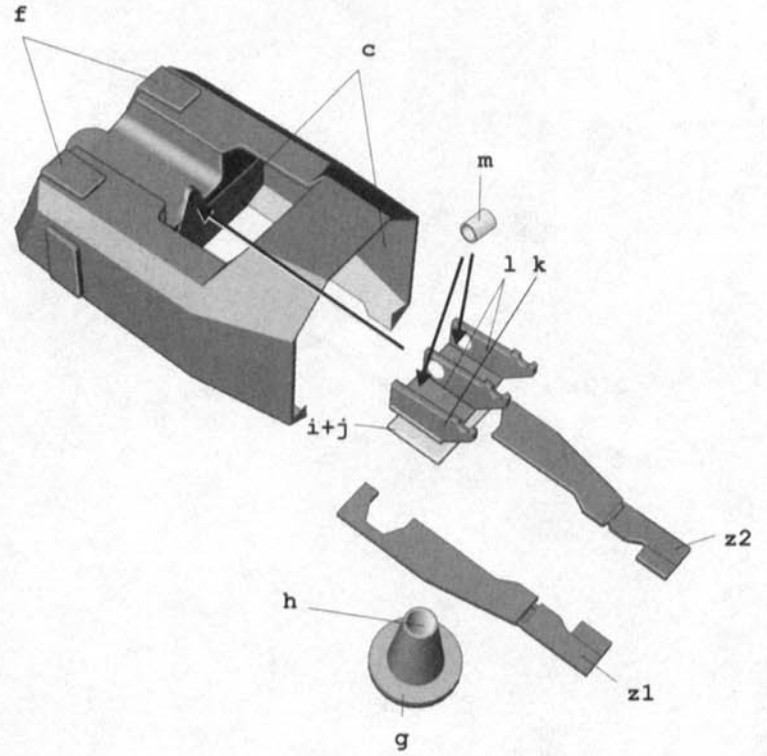

73. Teile/parts 254, Bogen/sheets 48-49

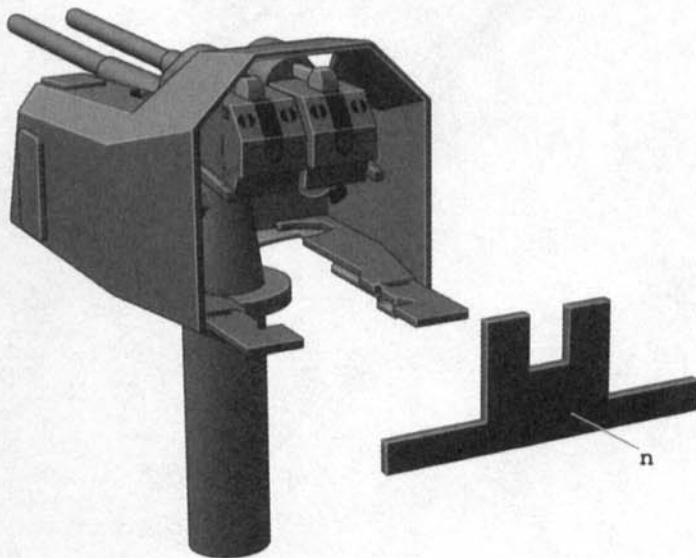

74. Teile/parts 254, Bogen/sheets 48-49

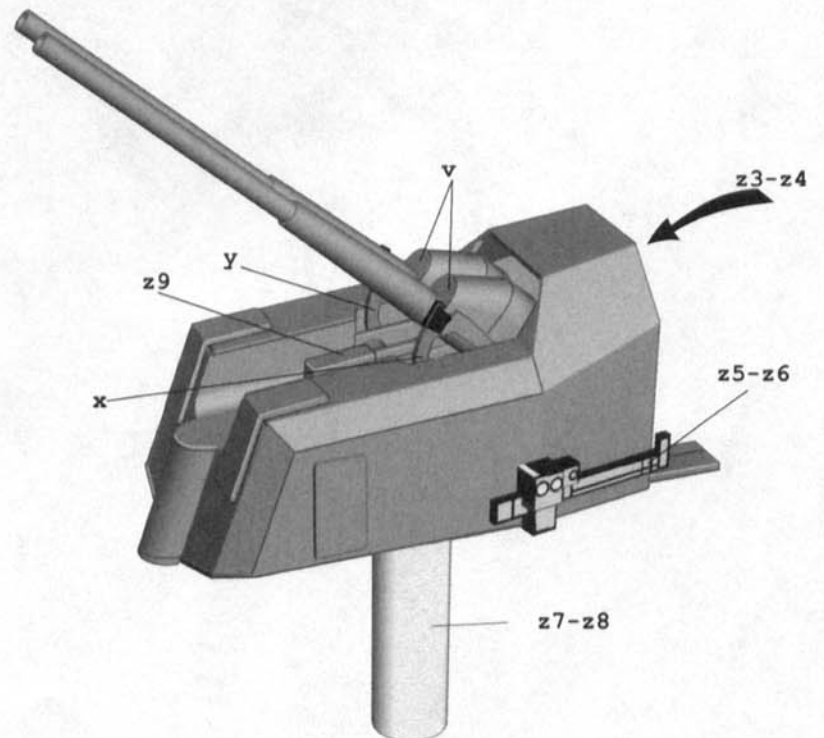

75. Teile/parts 255, Bogen/sheets 49

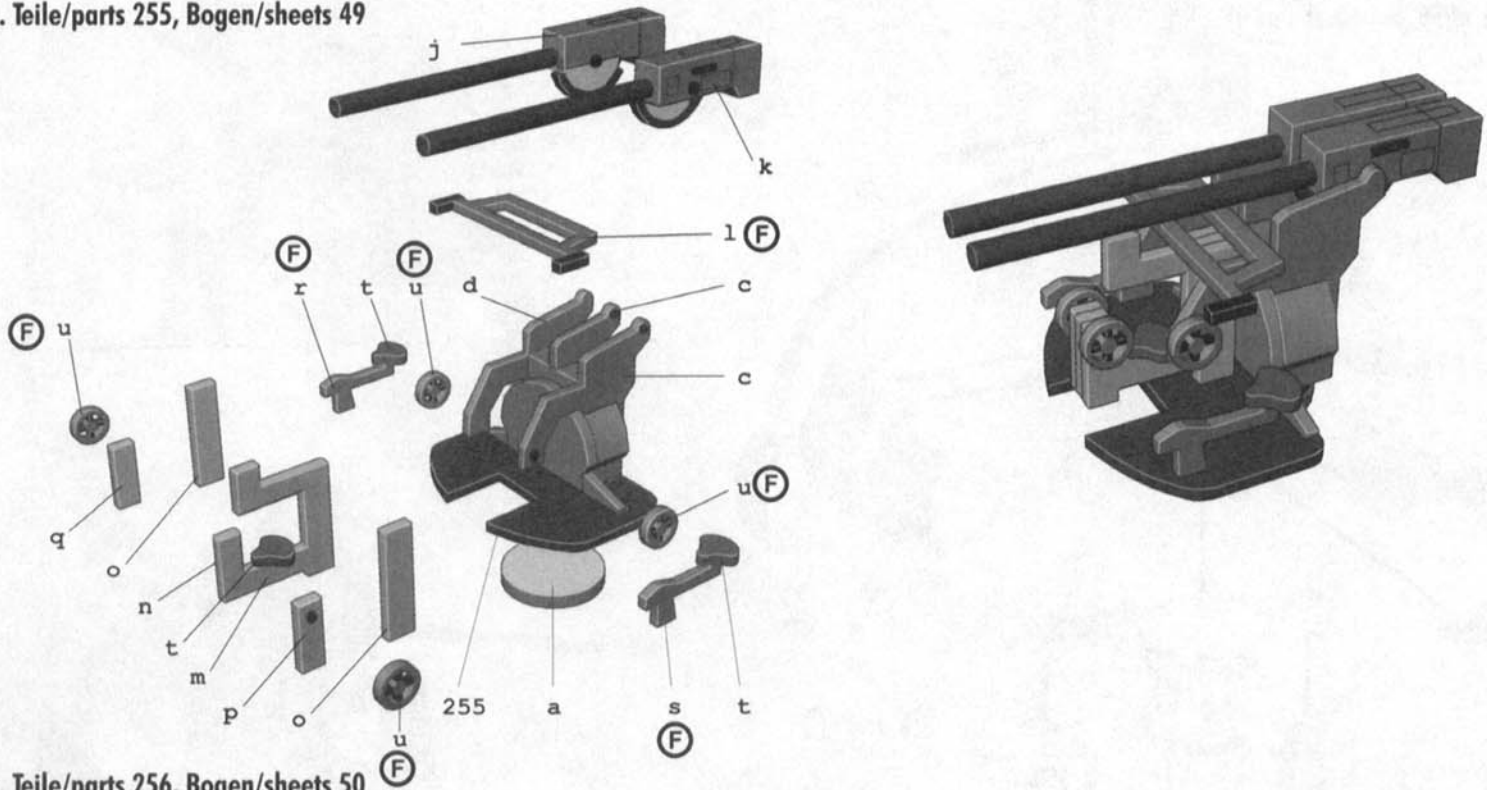

76. Teile/parts 256, Bogen/sheets 50

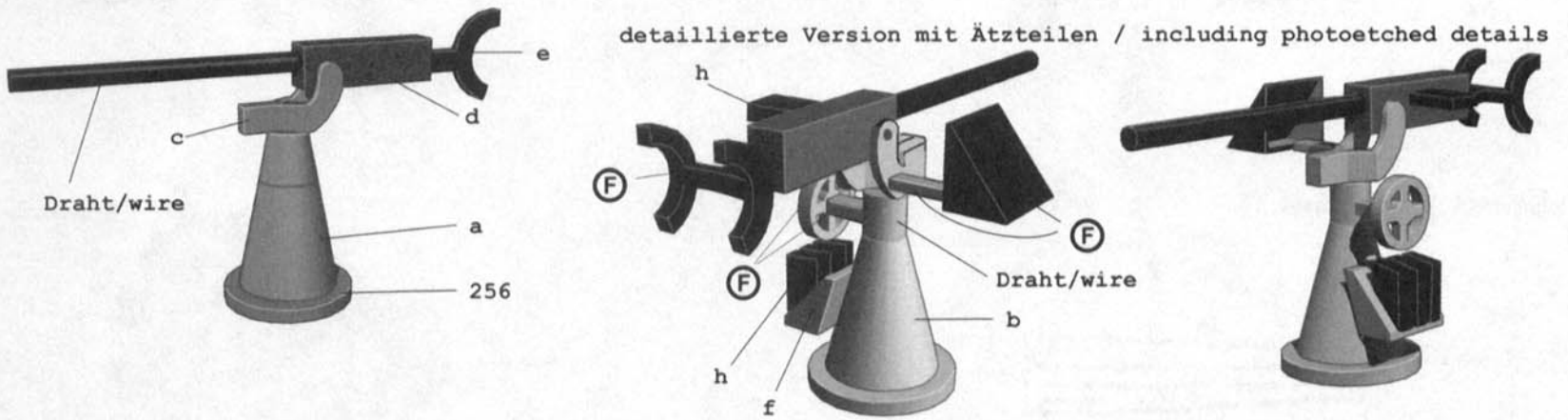

77. Teile/parts 257, Bogen/sheets 50

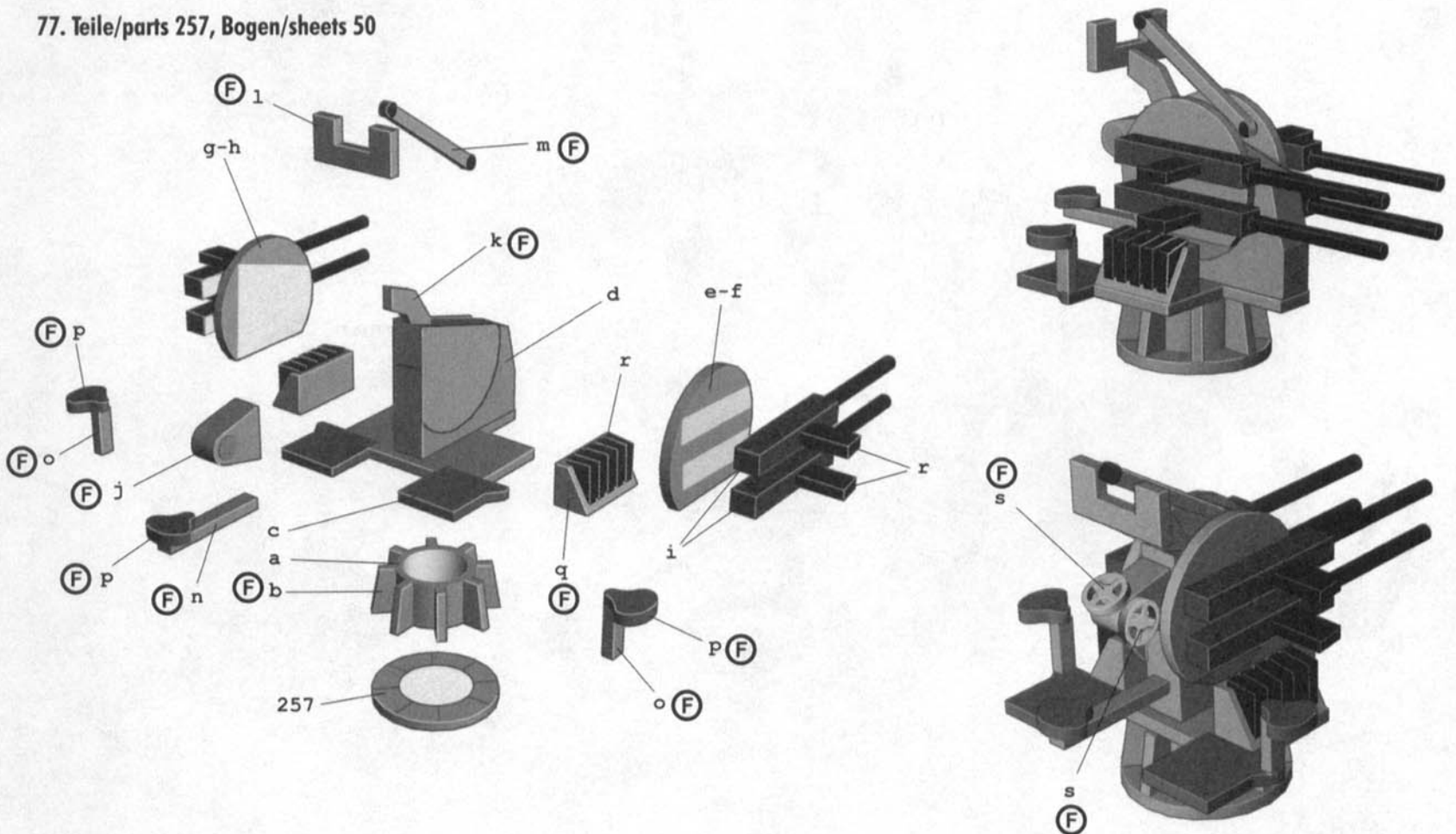

78. Teile/parts 258, Bogen/sheets 41

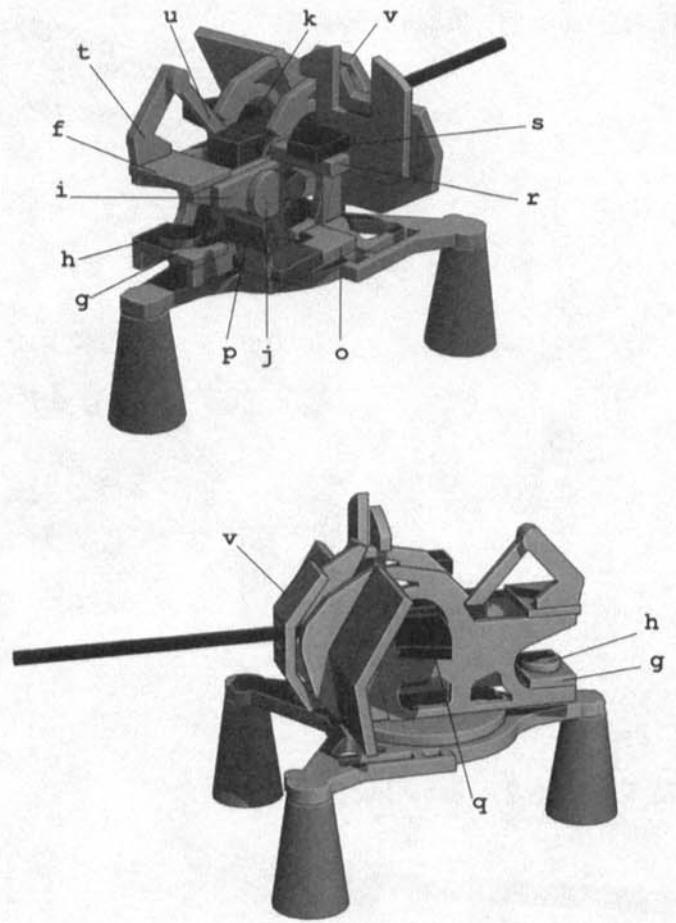
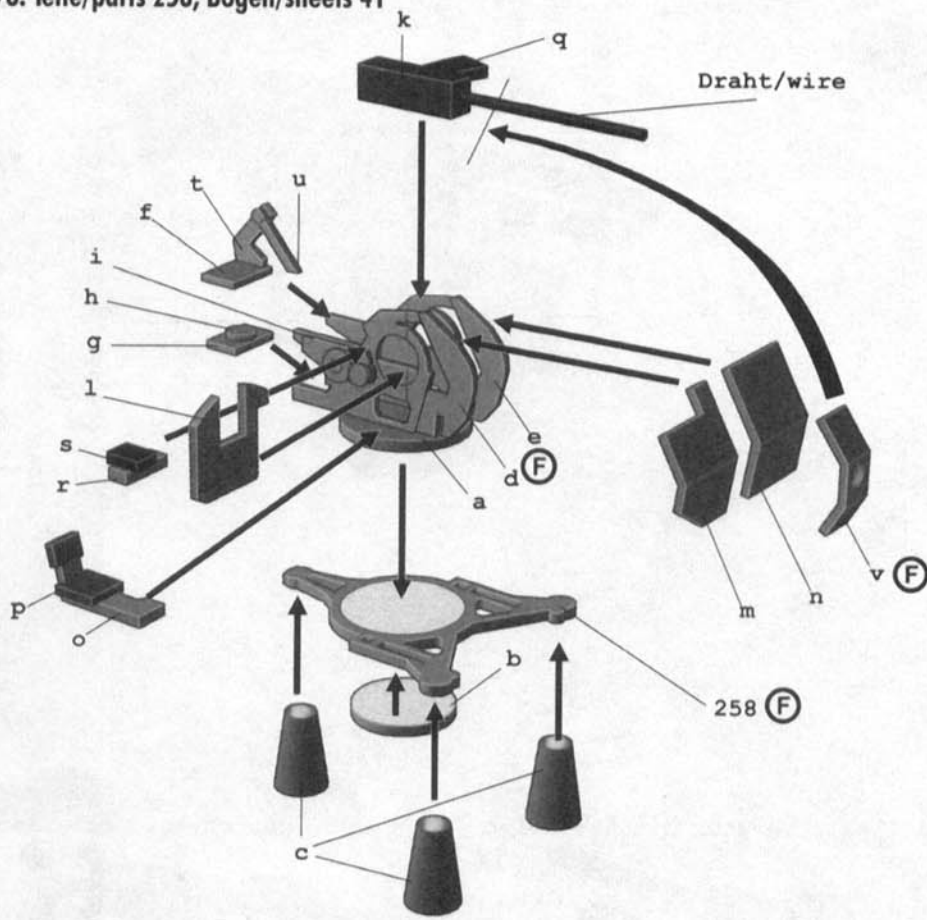

79. Teile/parts 259, Bogen/sheets 51

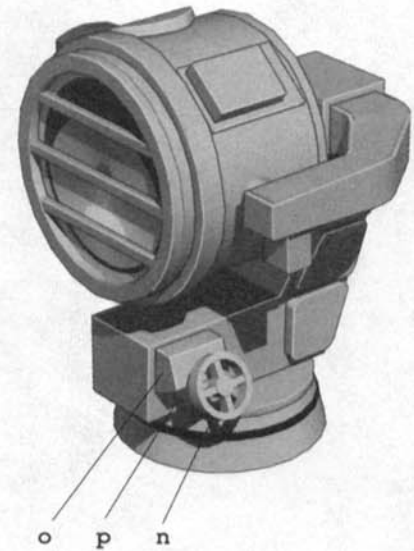
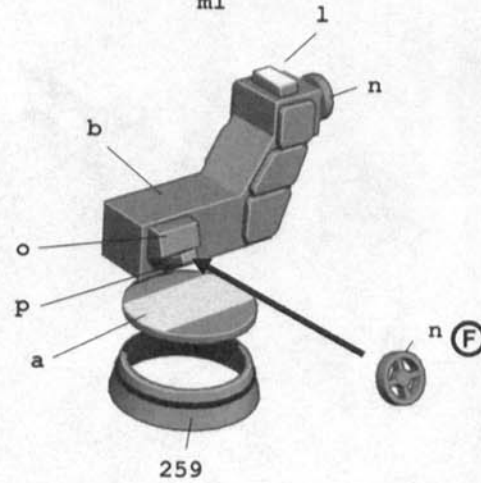
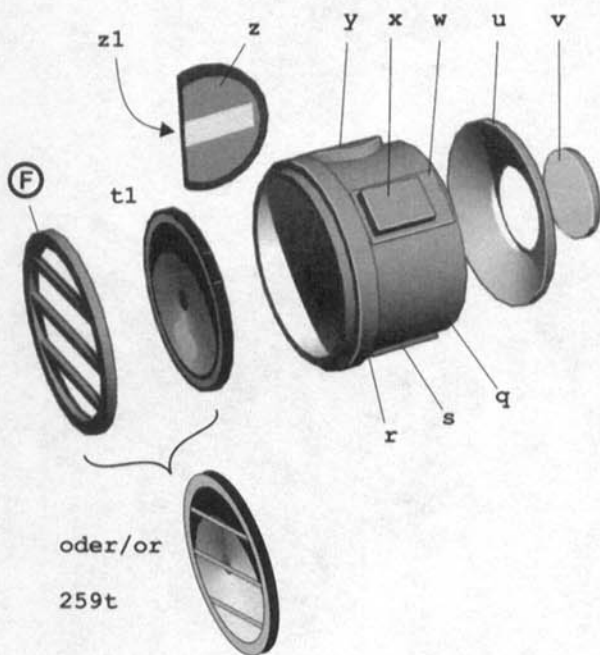
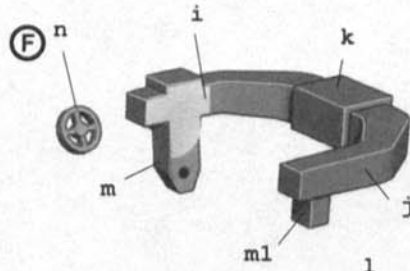
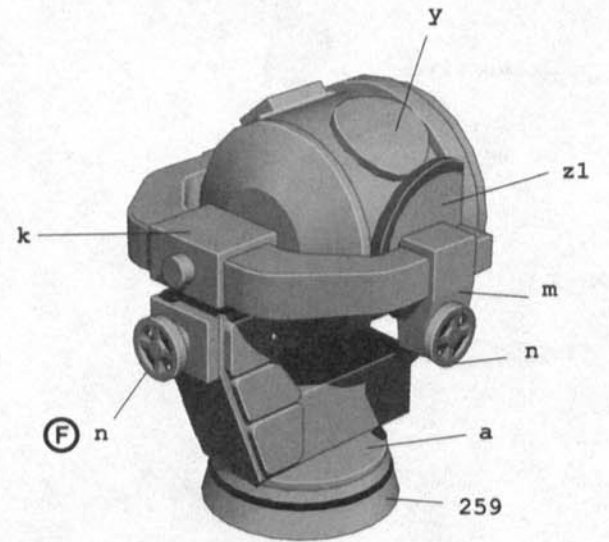
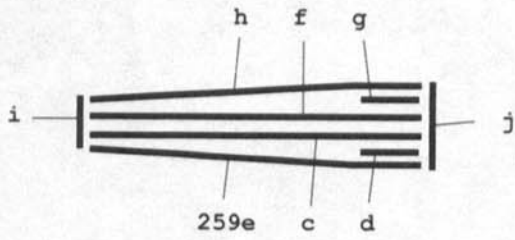

80. Teile/parts 260, Bogen/sheets 52

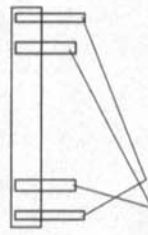
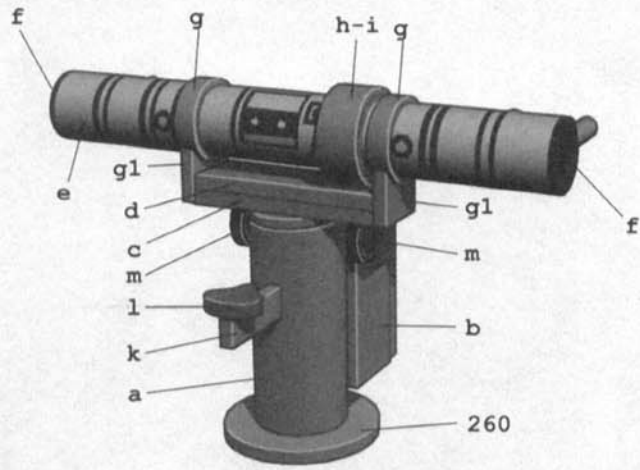

Draht/wire 4mm x 0,5mm ø
Draht/wire 3,5mm x 0,7mm ø

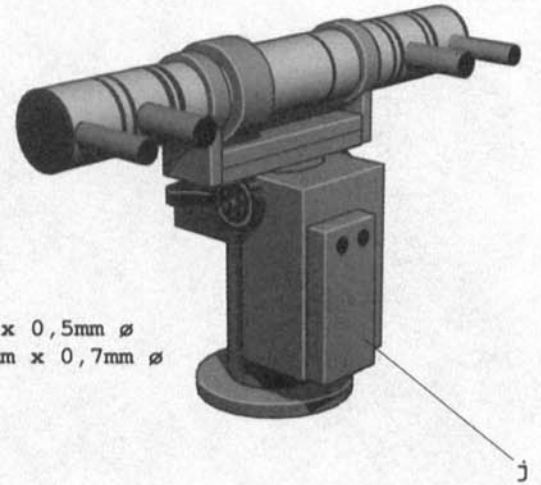

81. Teile/parts 261 - 265, Bogen/sheets 51 - 52

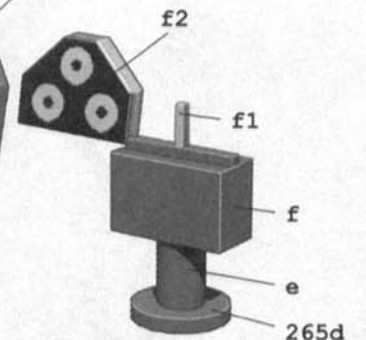
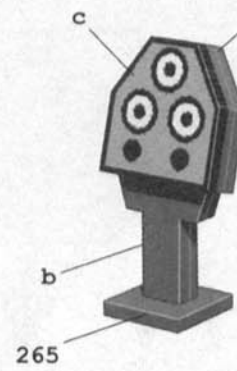
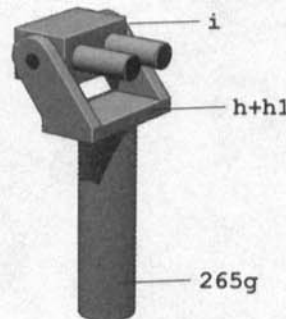
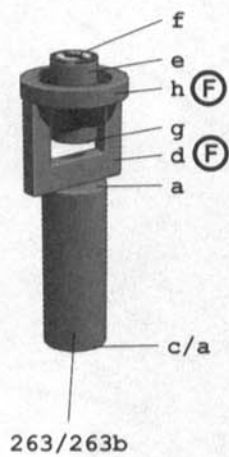
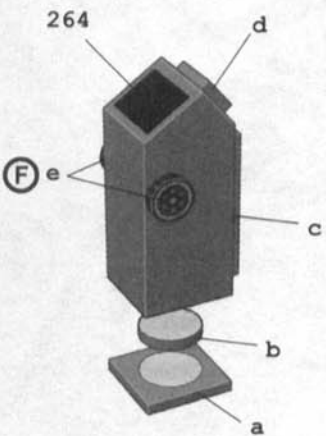
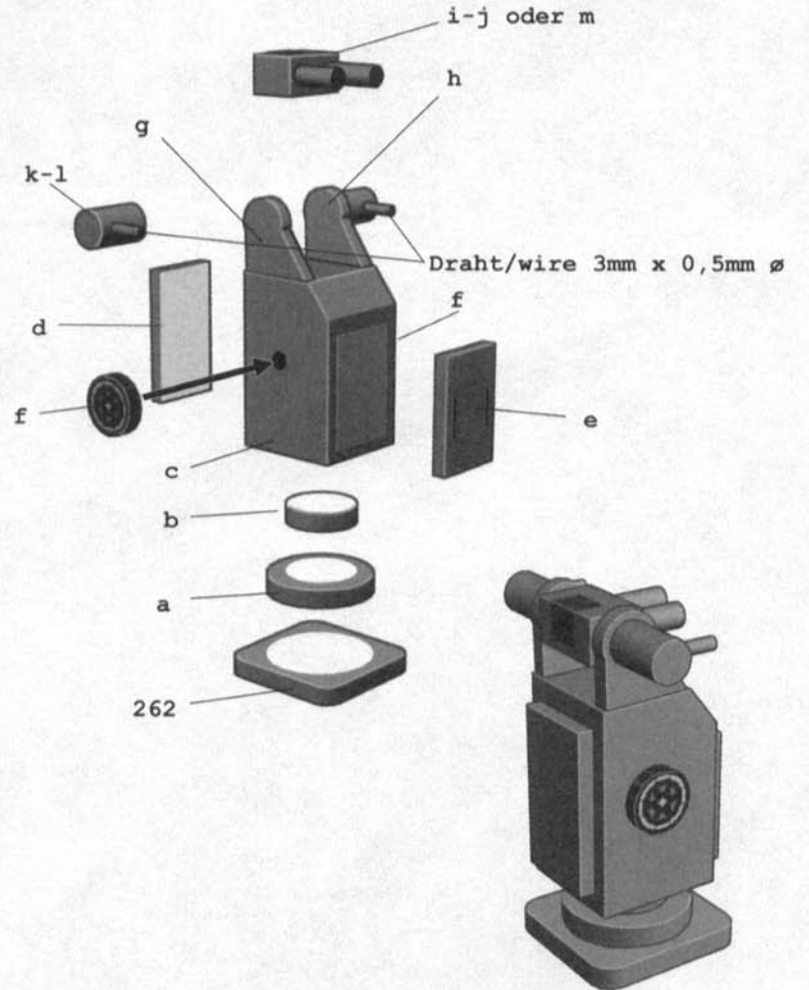
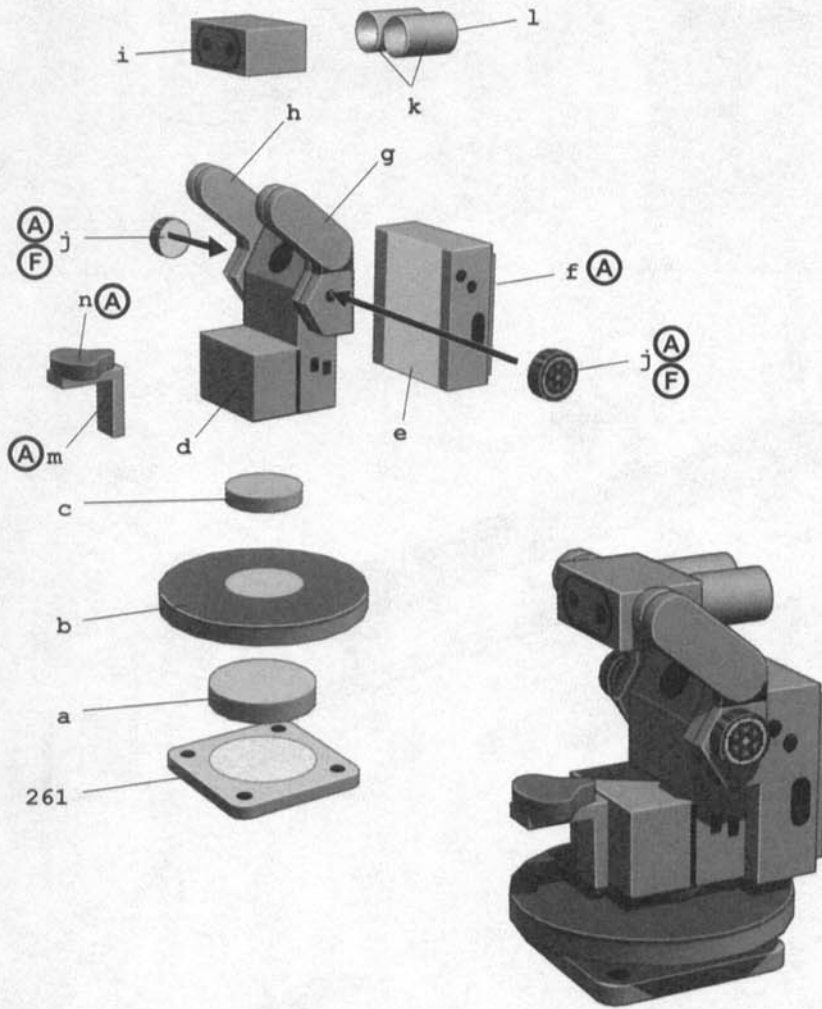

82. Teile/parts 260-266, Bogen/sheets 51-53

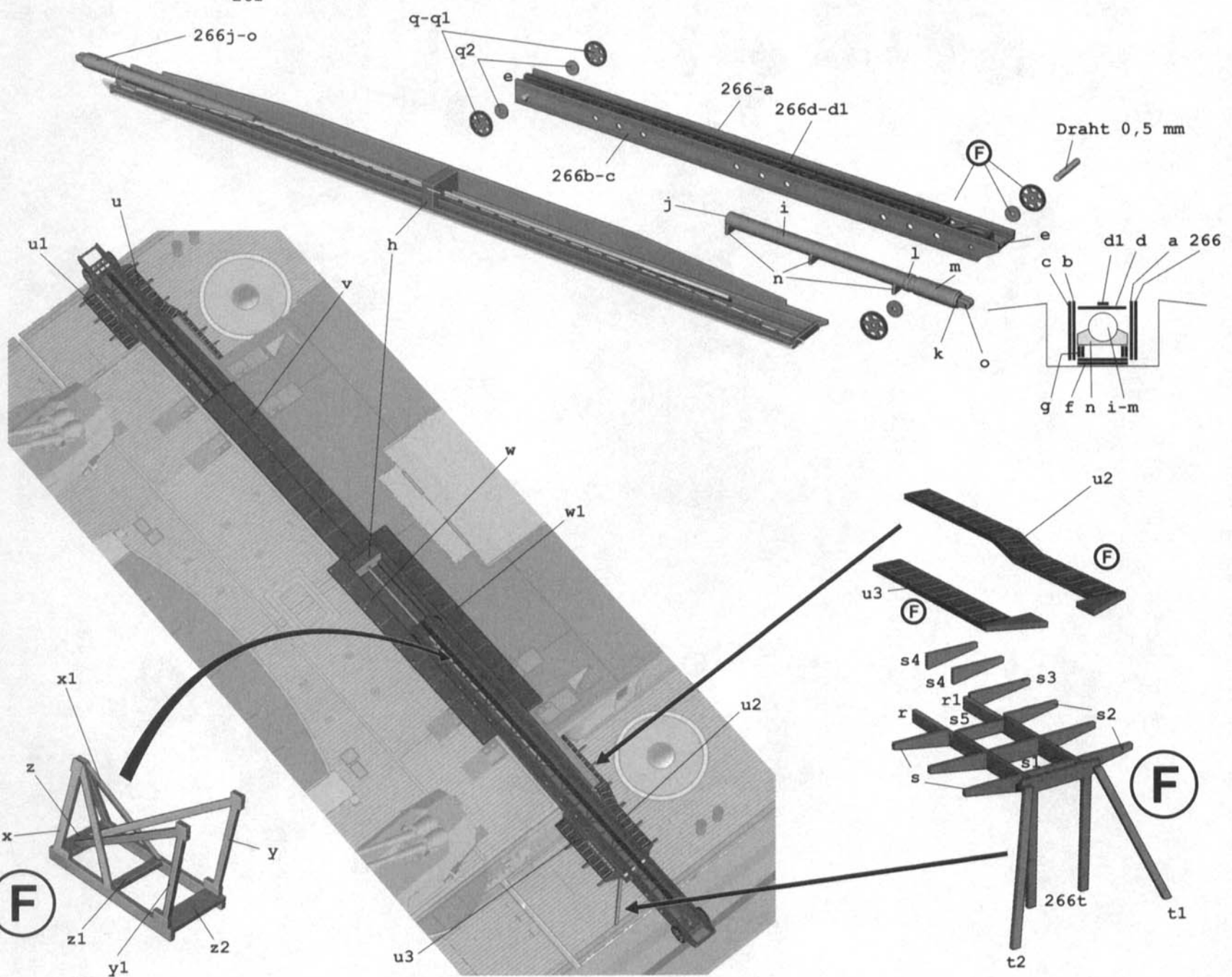
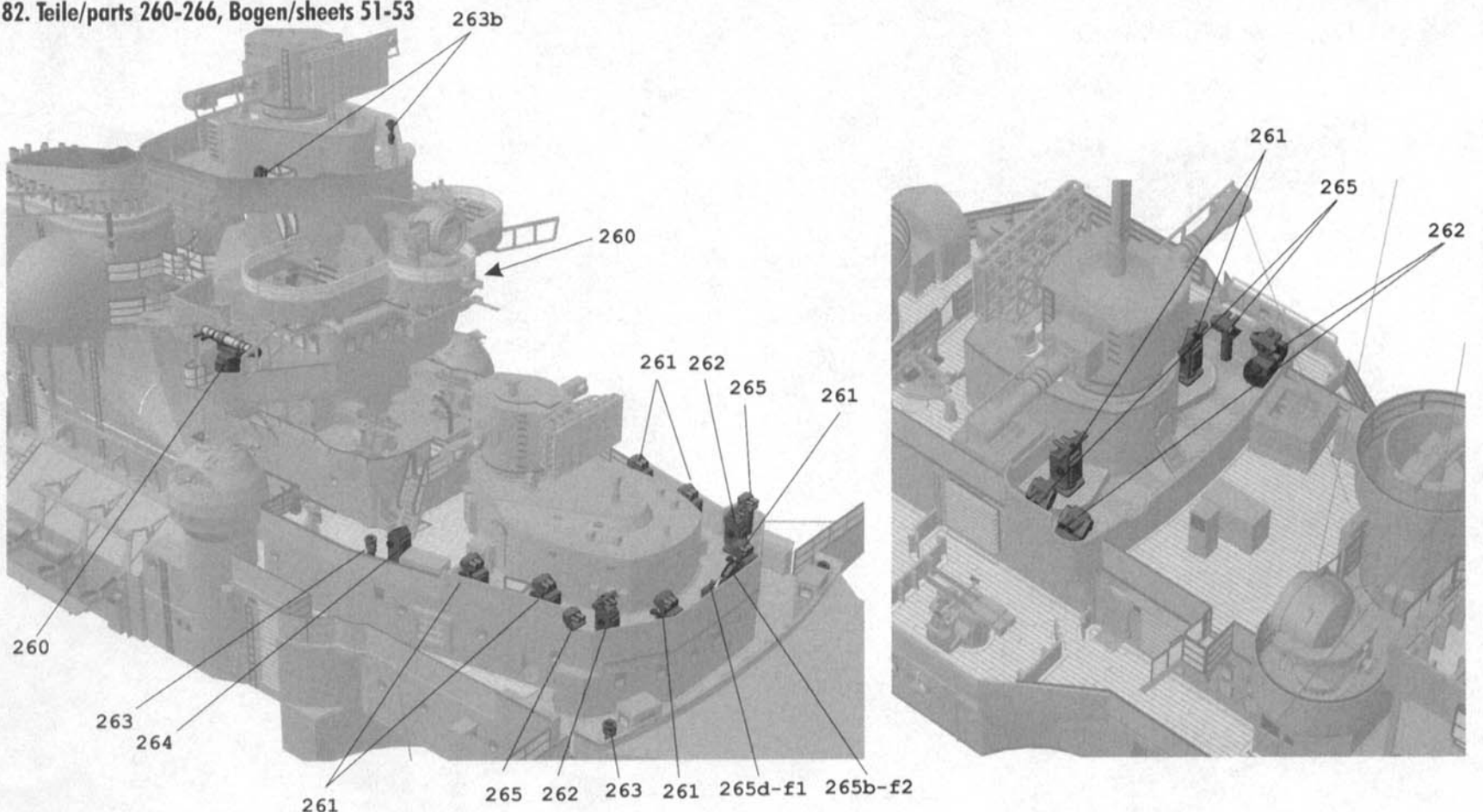

83. Teile/parts 267, Bogen/sheets 54

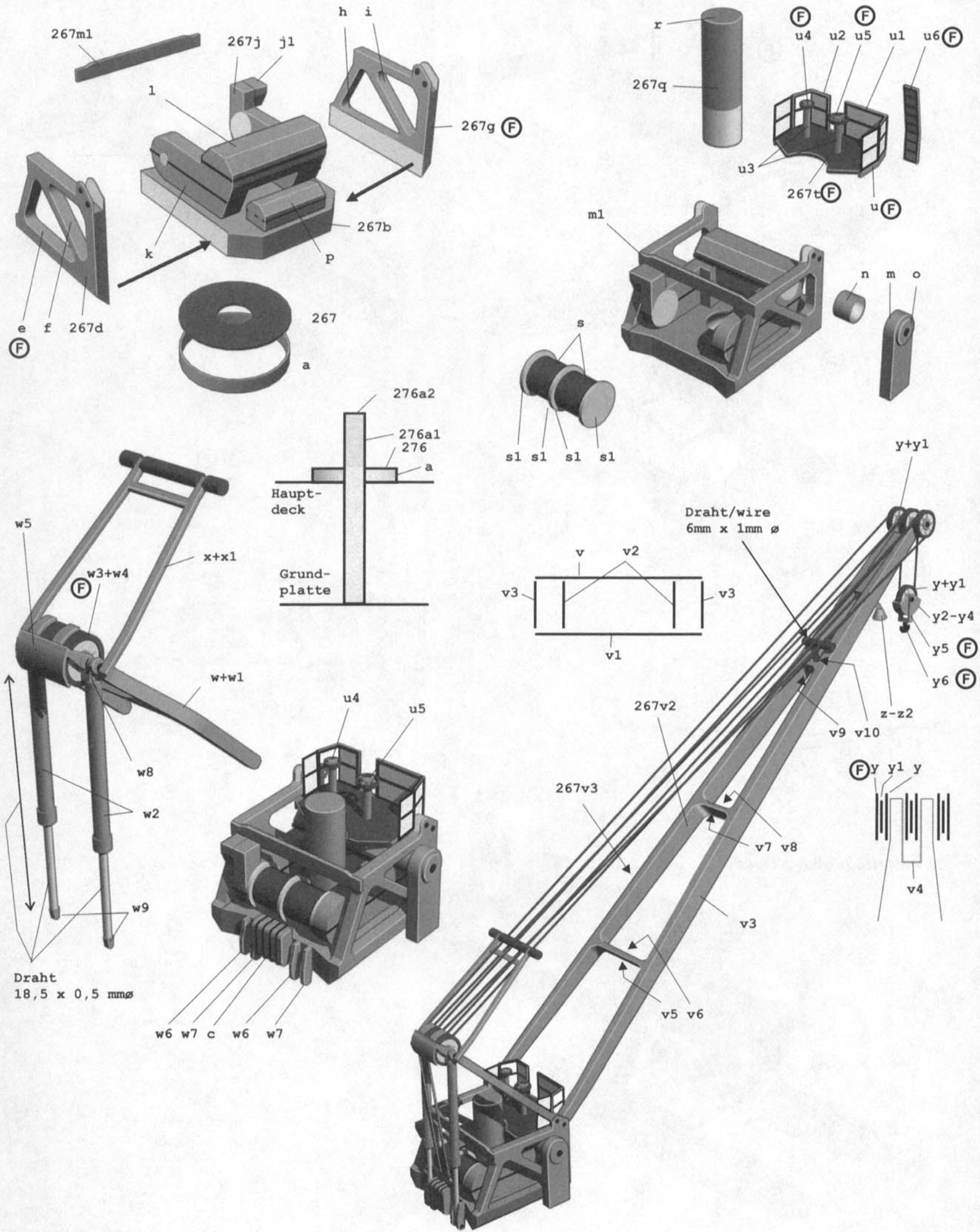

84. Teile/parts 268, Bogen/sheets 55

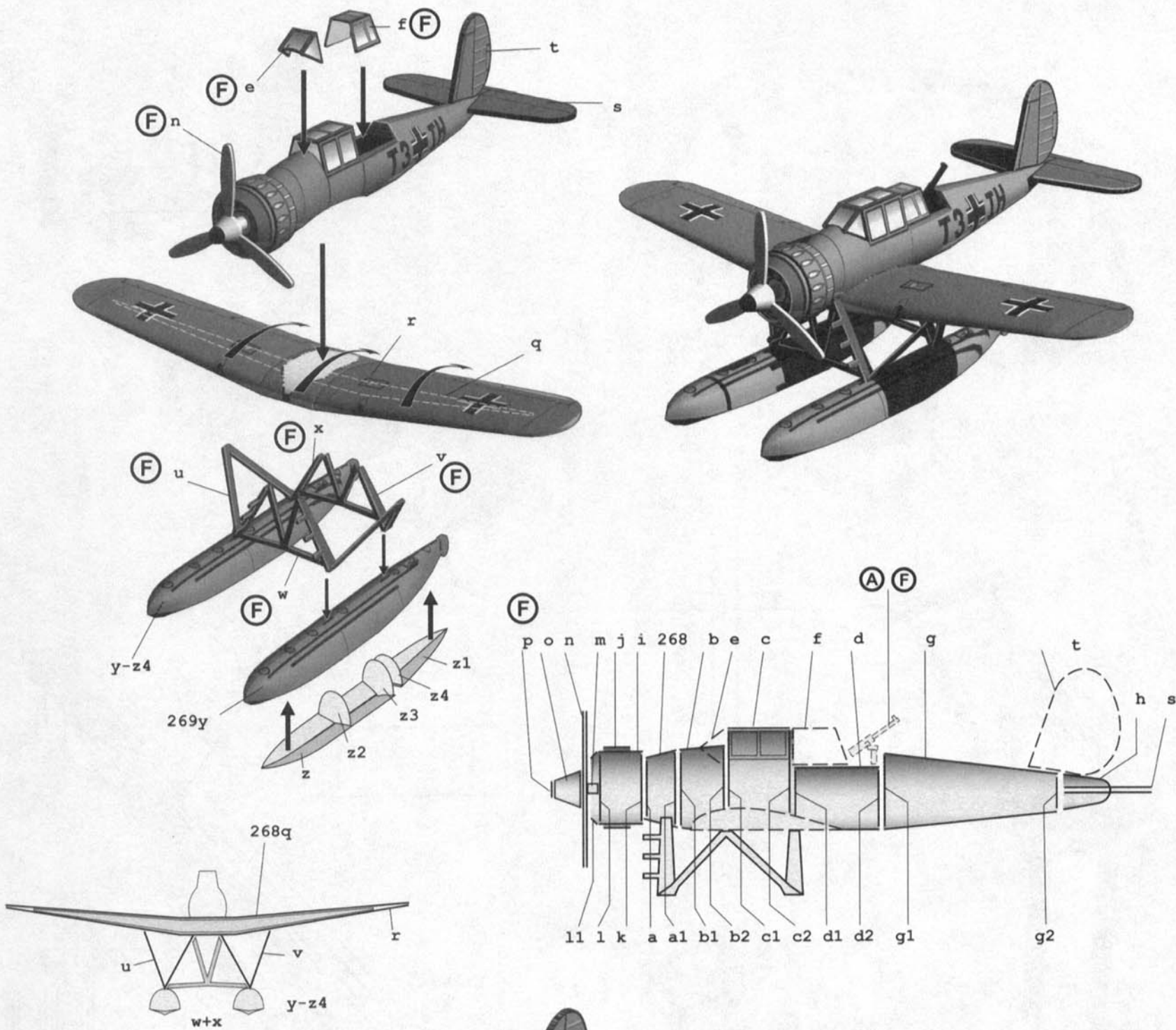

85. Teile/parts 269, Bogen/sheets 54

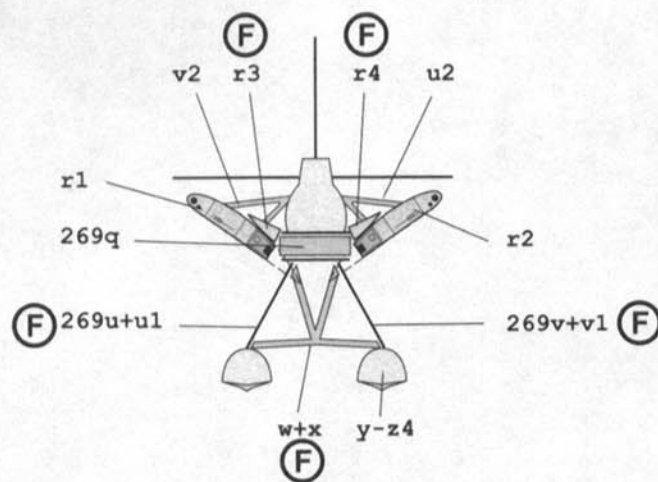
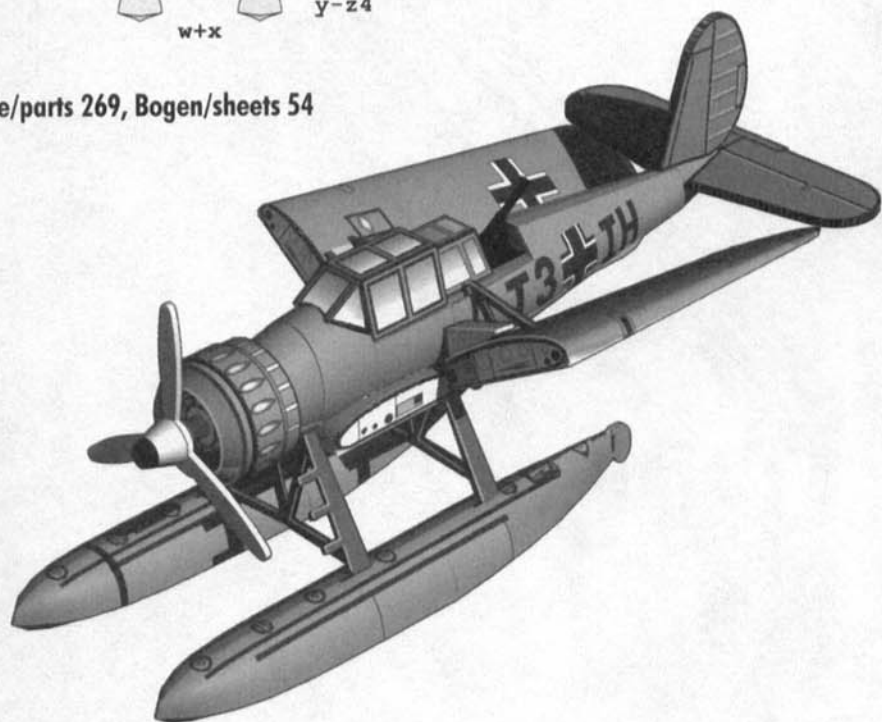

86. Teile/parts 270, Bogen/sheets 56

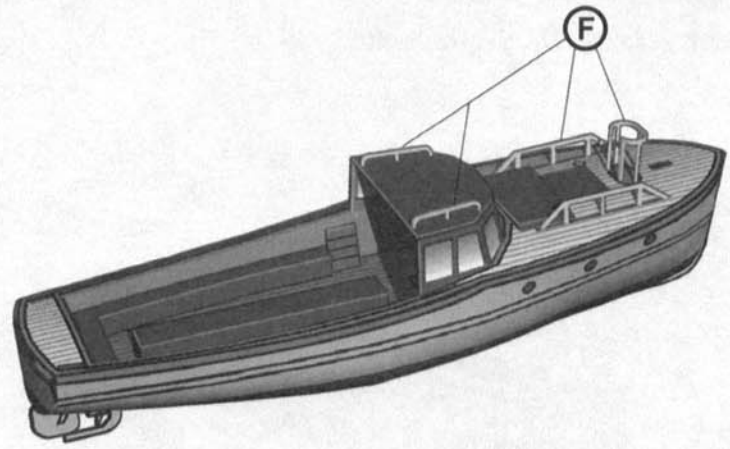
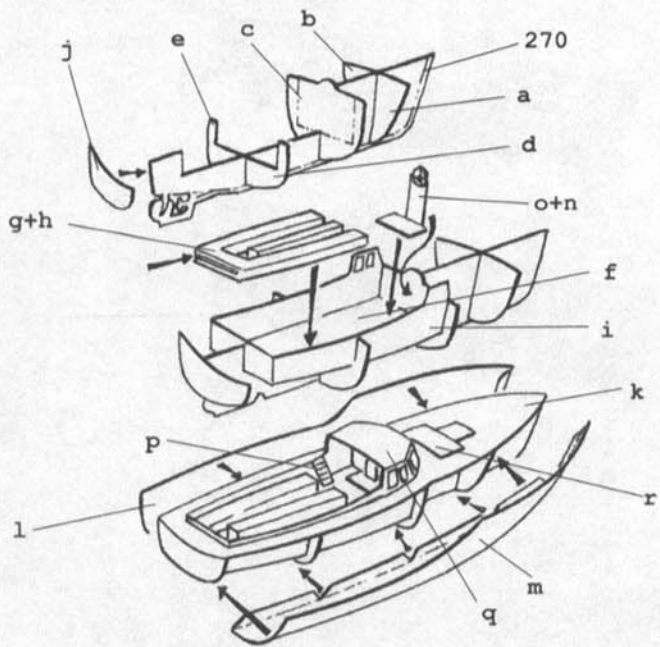

87. Teile/parts 271, Bogen/sheets 52 + 56

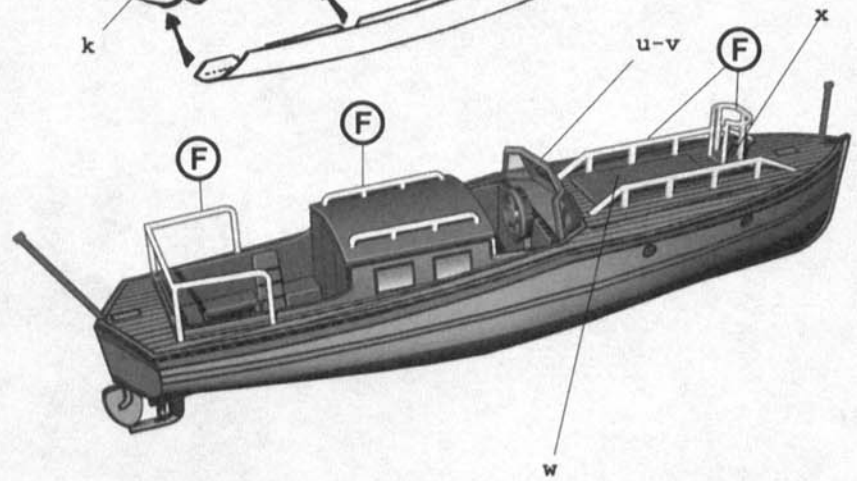
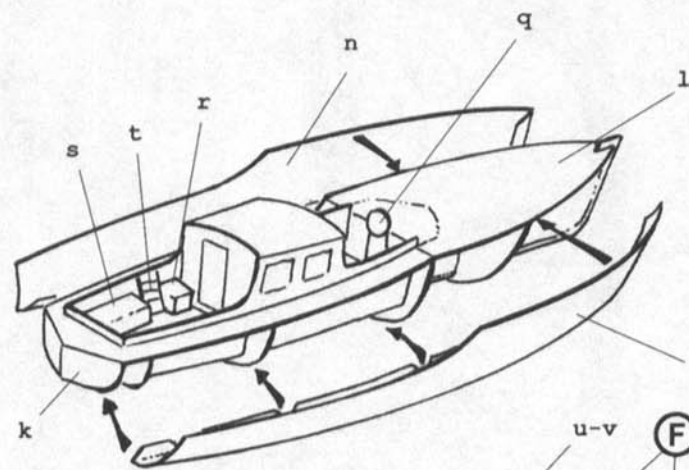
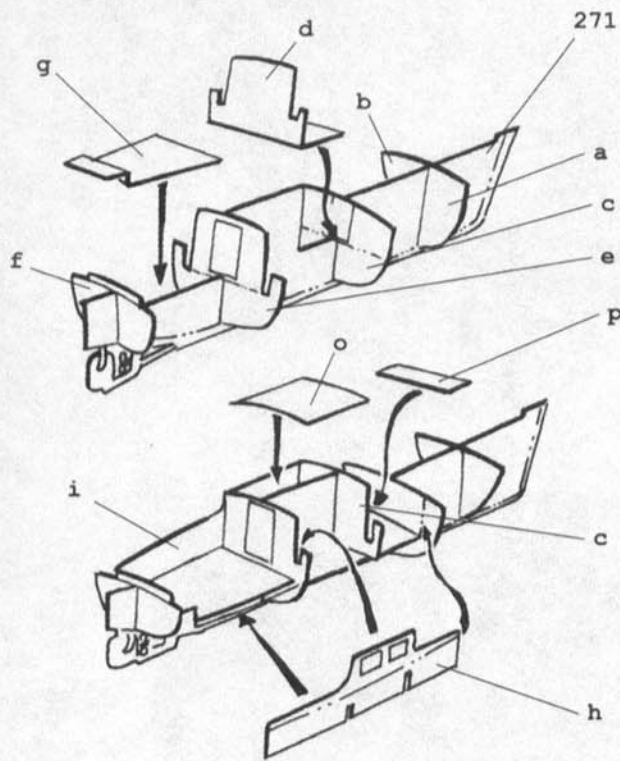

88. Teile/parts 272, Bogen/sheets 57

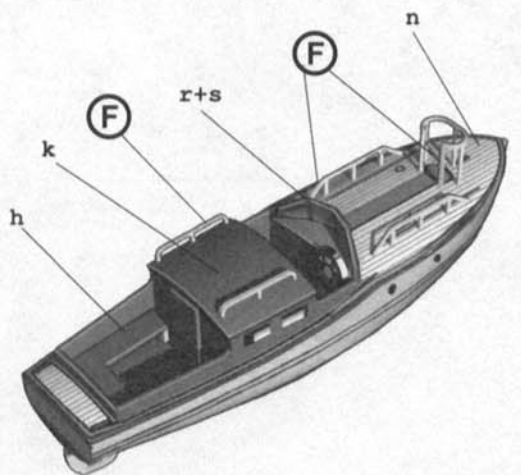
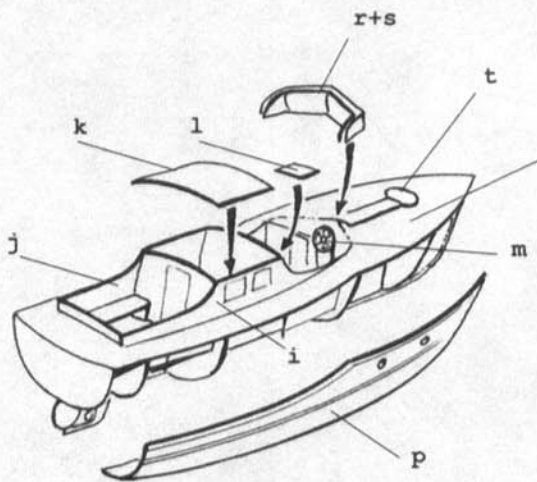
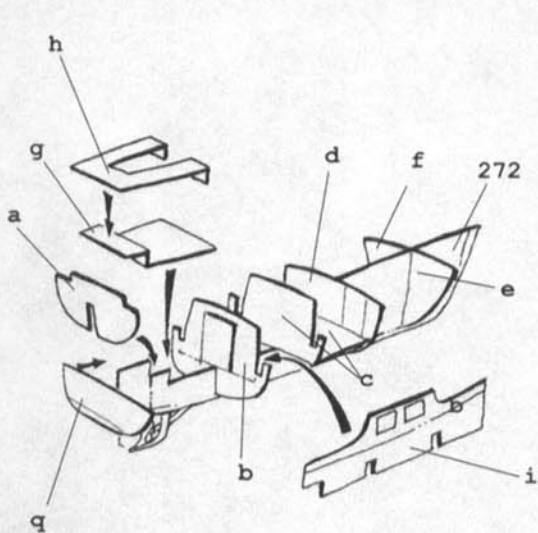

89. Teile/parts 273, 274, 276, Bogen/sheets 57+59

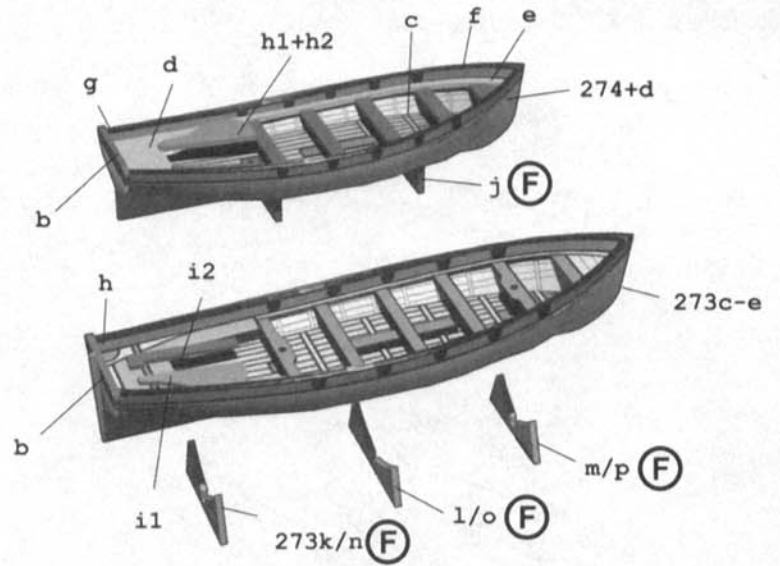
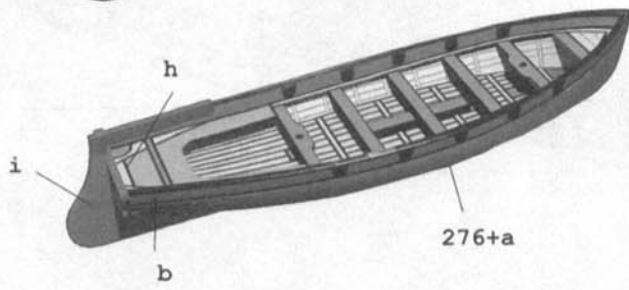

90. Teile/parts 275, Bogen/sheets 59

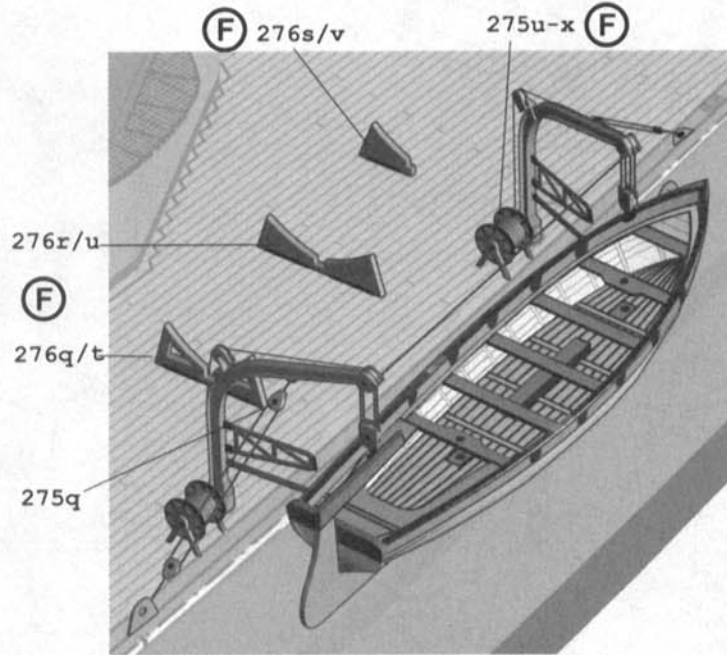
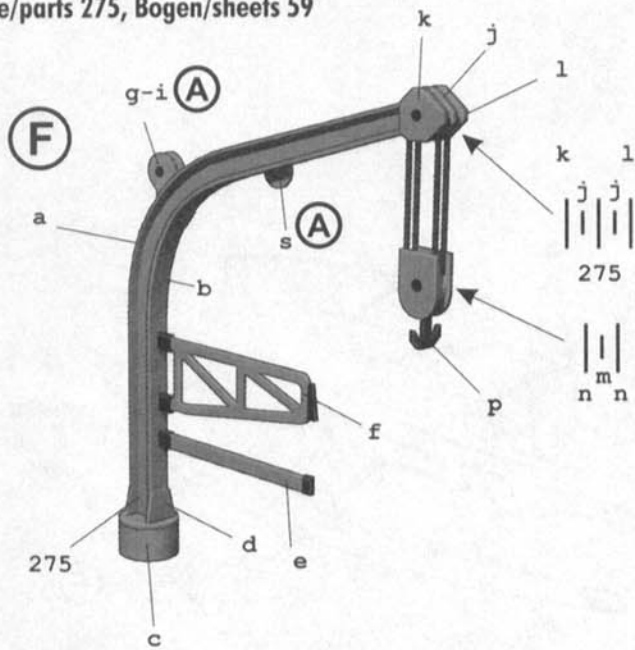

Backbord-Seite: 276t-v

91. Teile/parts 277, 278, Bogen/sheets 58

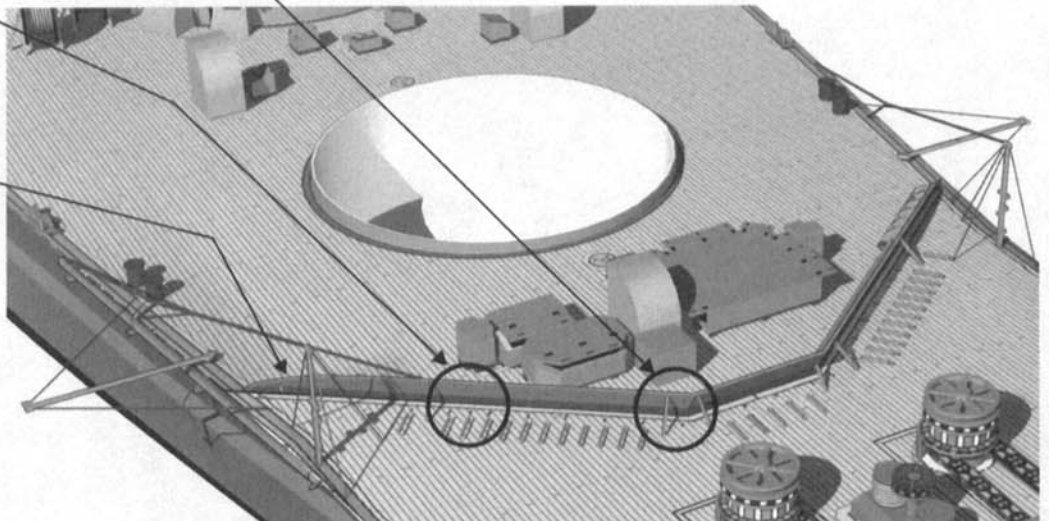
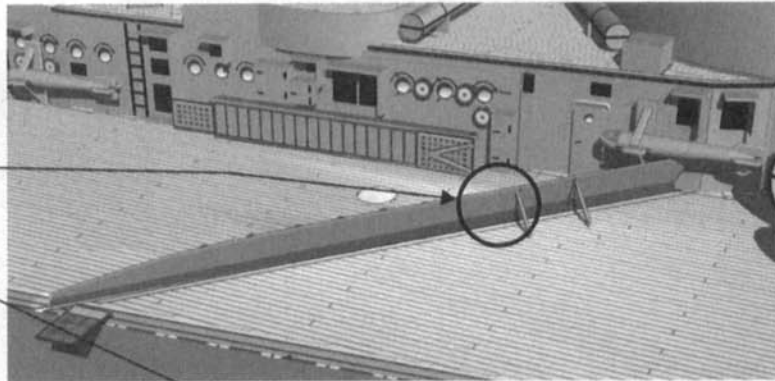
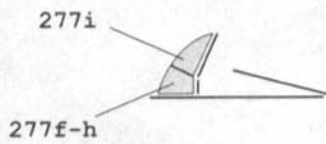
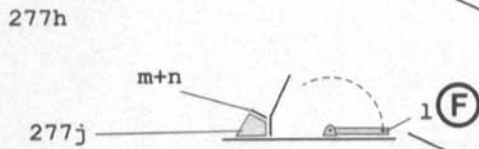
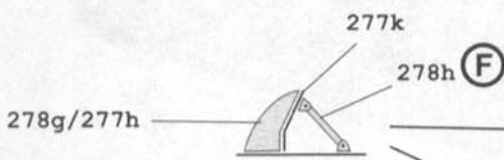

92. Teile/parts 278-315, Bogen/sheets 53, 58-60

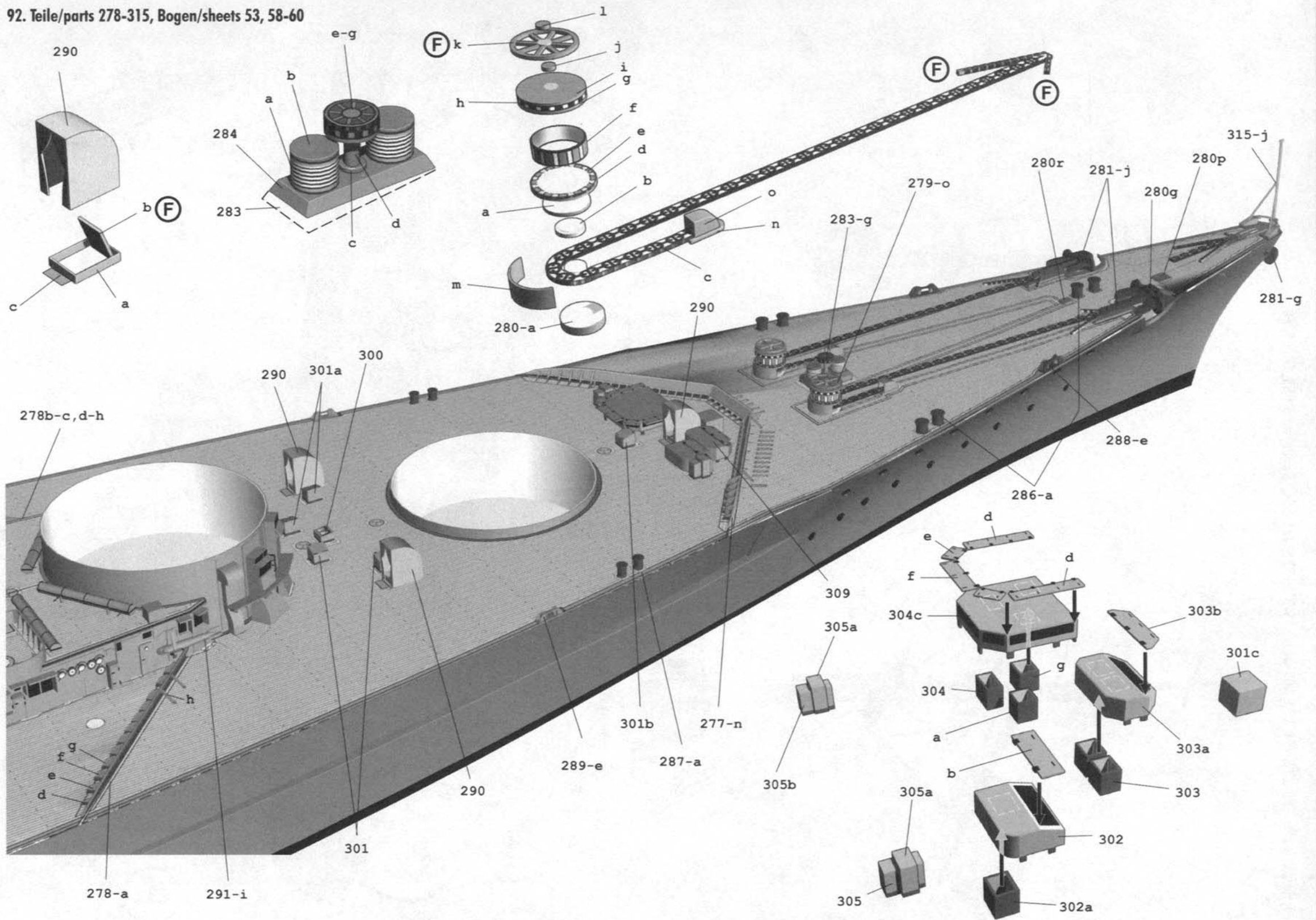

93. Teile/parts 275, 280-282, 291, 293, 305-311, 315-319, 321, 323, 324, Bogen/sheets 53, 58, 59, 60

F

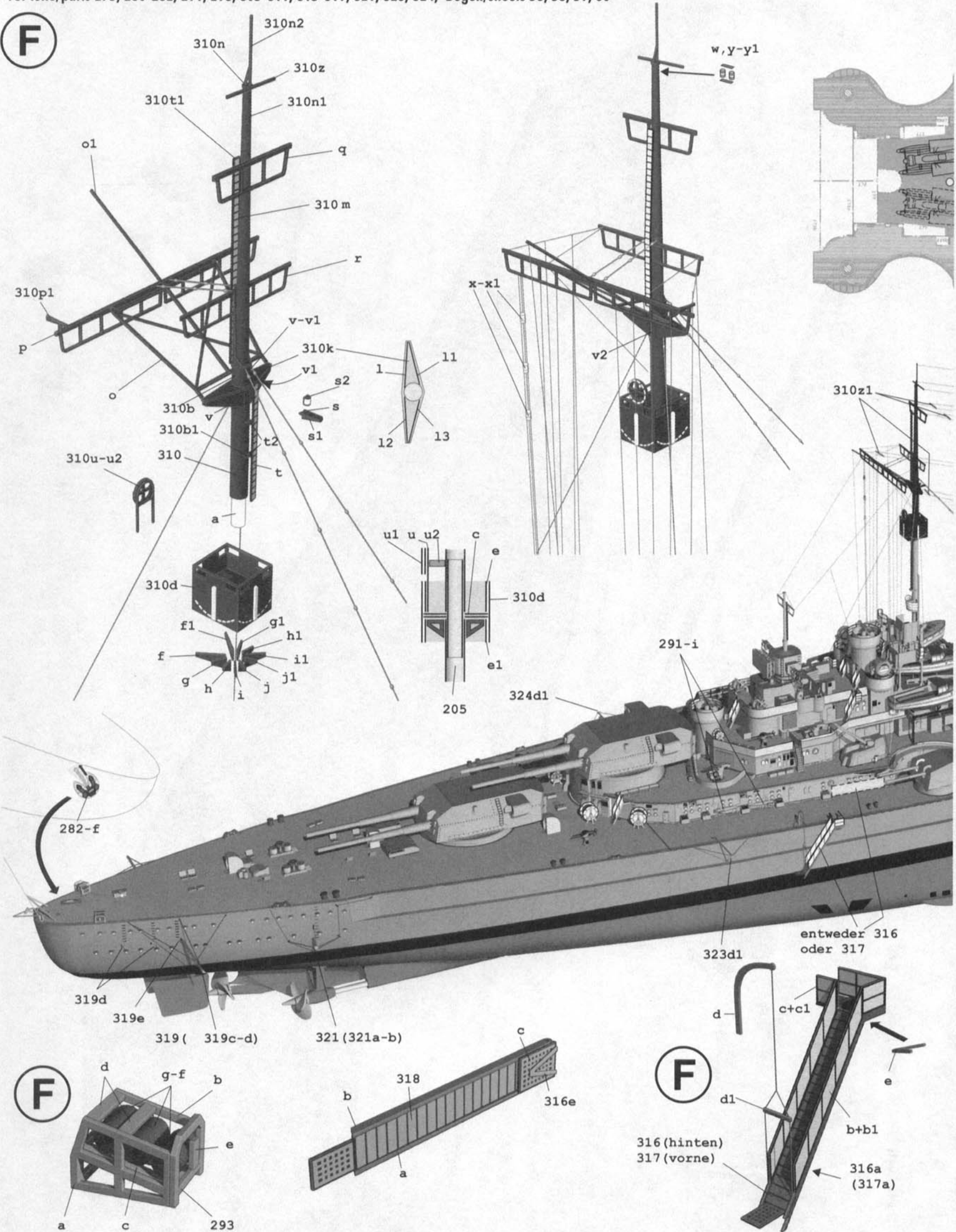

F

F

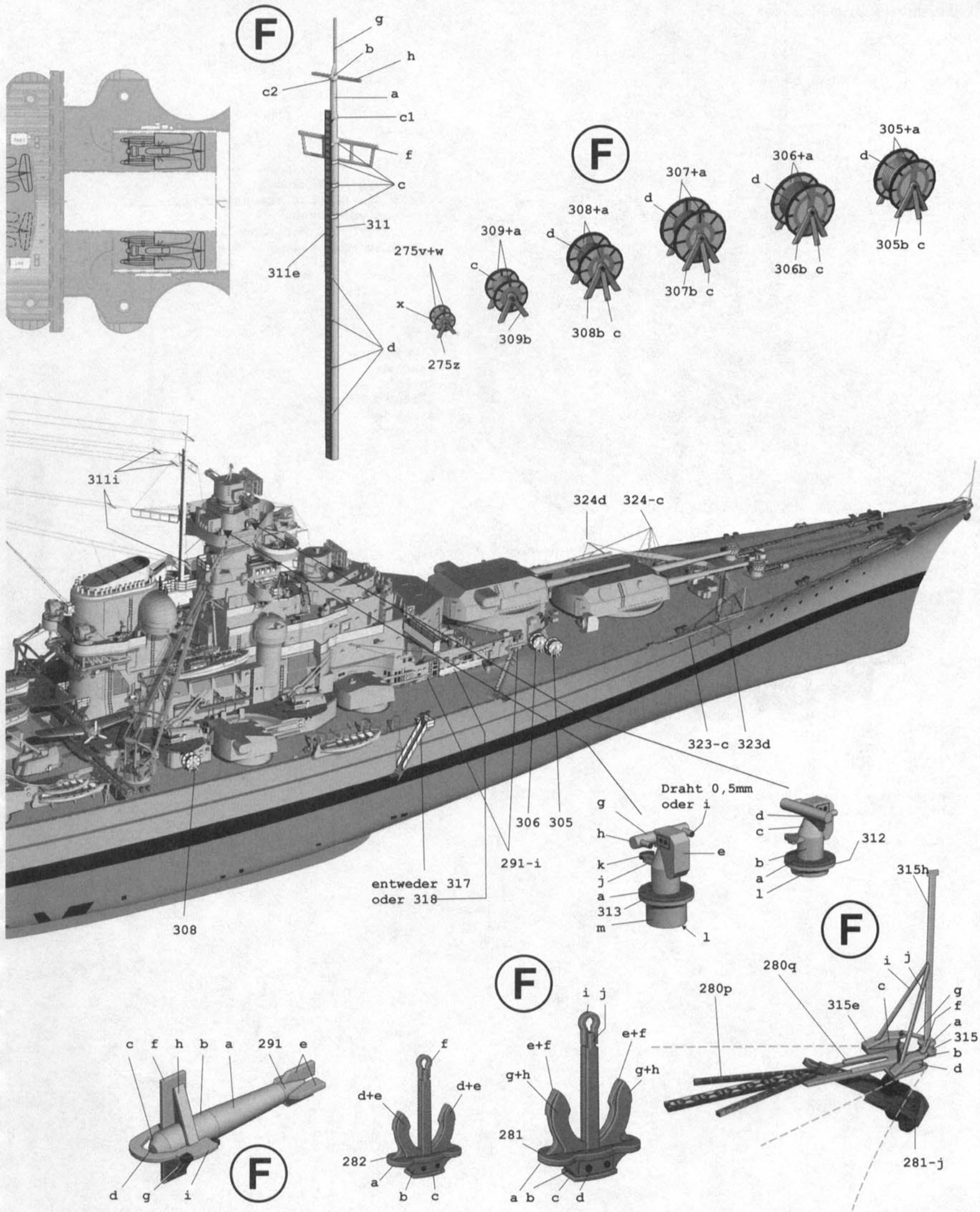

94. Überblick über Bauteil-Positionen

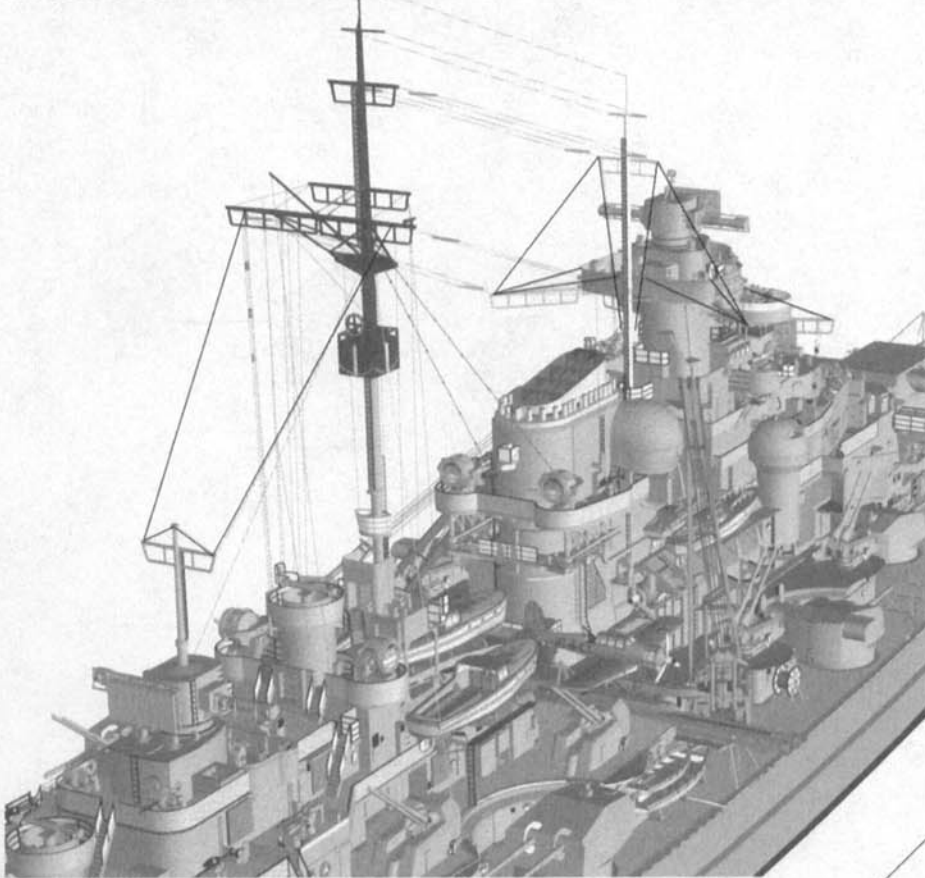

Hintere Kugelhauben für die FLA-Entfernungsmesser waren vorgesehen (siehe Fotos Werftmodell und Schwesterschiff "Tirpitz")

Ladeübungs-Kanonen, waren zu diesem Zeitpunkt nicht mehr an Bord

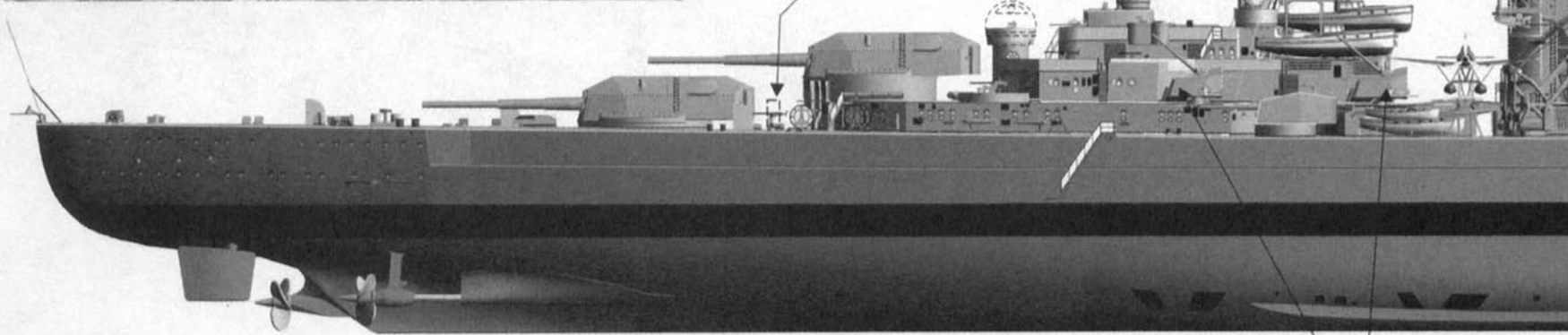

Später hier 10,5cm-Flak (neuere Ausführung C 37, auf "Tirpitz" nur C 37)

Wasserbomben-Ablaufbühne ab April/Mai 1941 an Bord

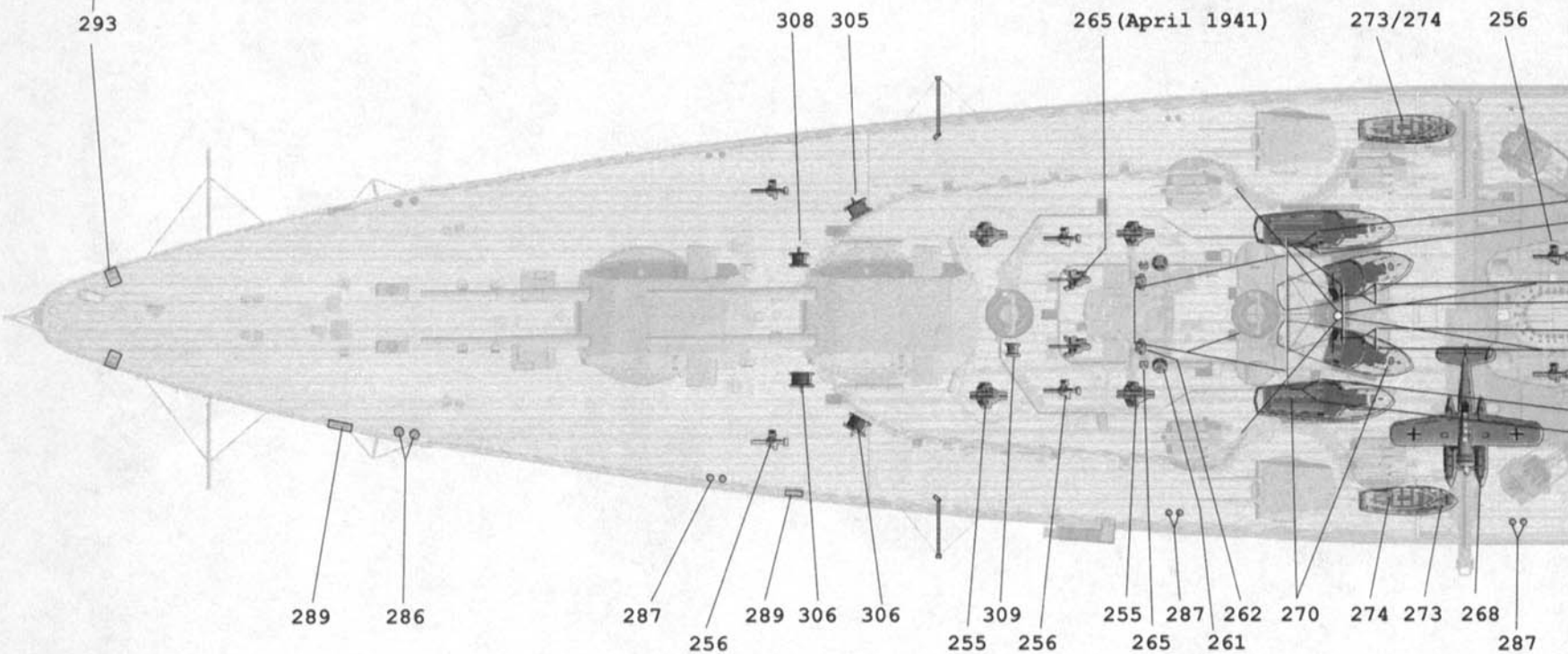

Kran bei Katapult-Start
der Arado 196

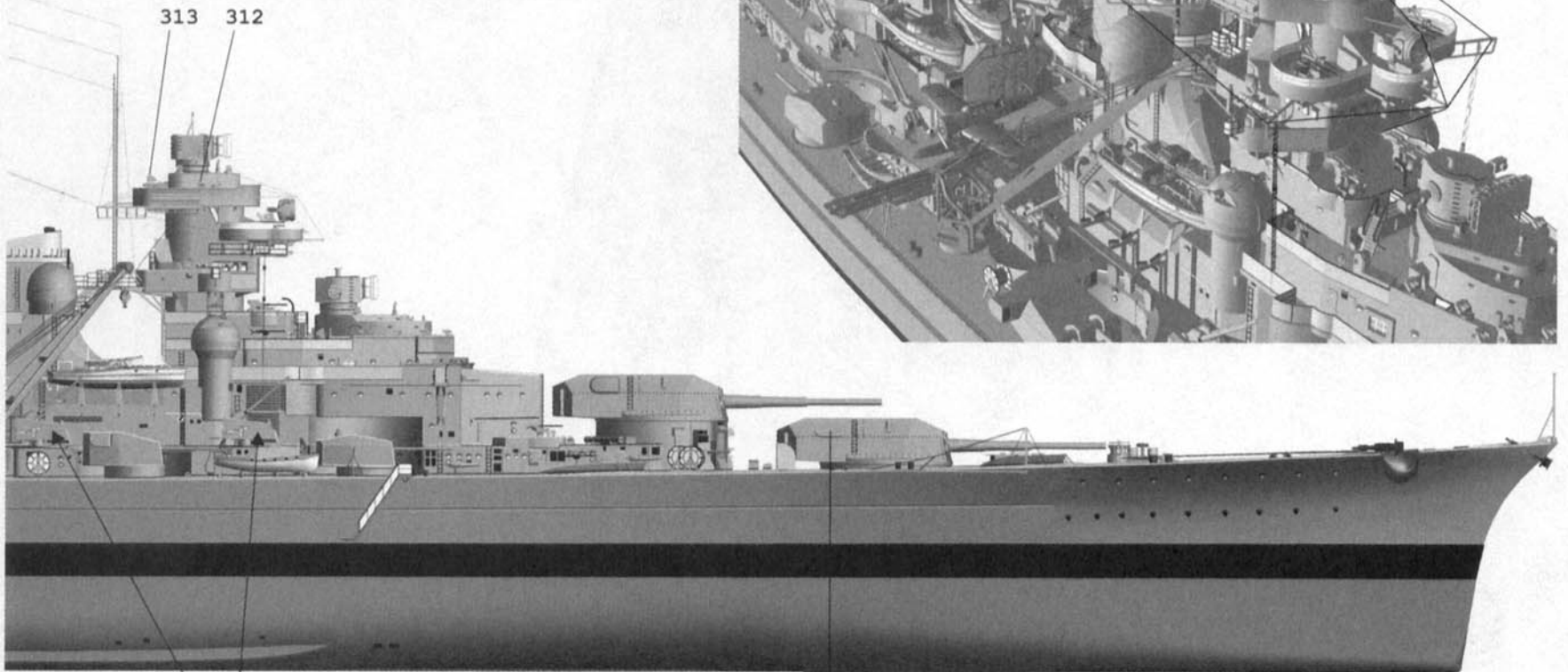
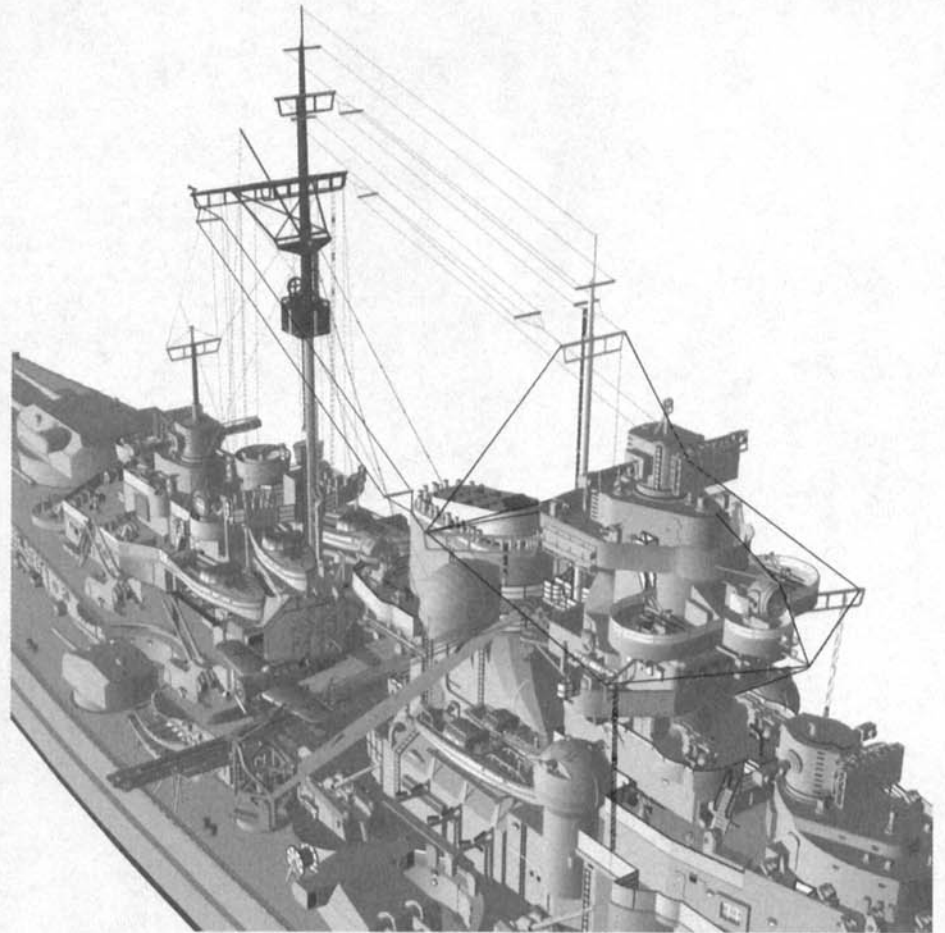
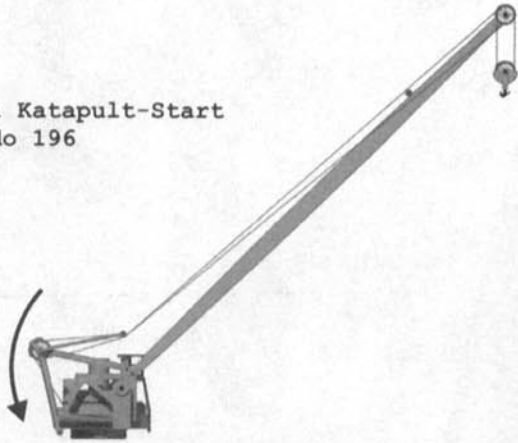

Anfangs nur hier 10,5cm-Flak
(ältere Ausführung C 31)

*ZAG: Ziellanweisungsgerät

Entfernungsmesser Turm "Anton"
waren anfangs eingebaut,
wurden später ausgebaut
(siehe Originalfoto)

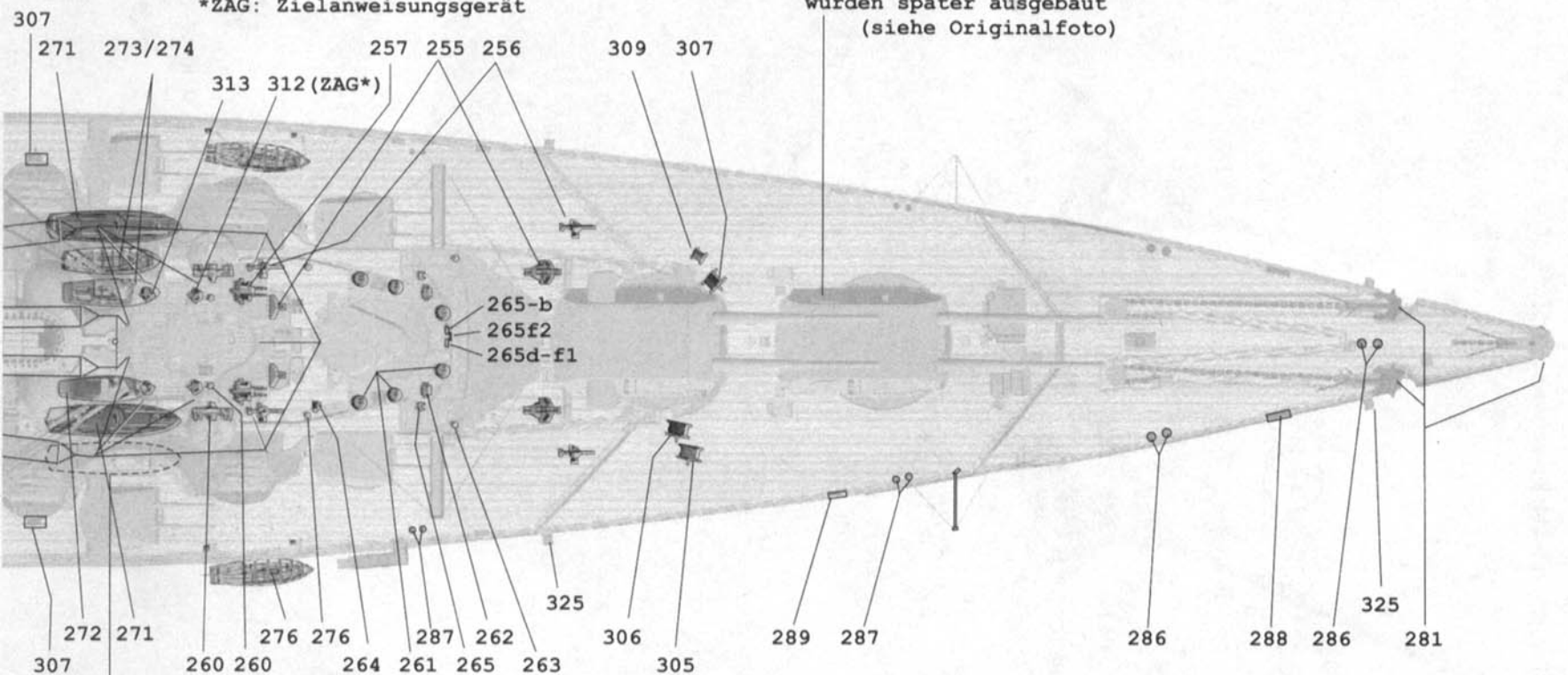

3. Motorbarkasse (271 auf Bogen 57)
war zwar vorgesehen, war aber nie an Bord

95. Teile/parts 269-314, Bogen/sheets 53, 55, 58, 60

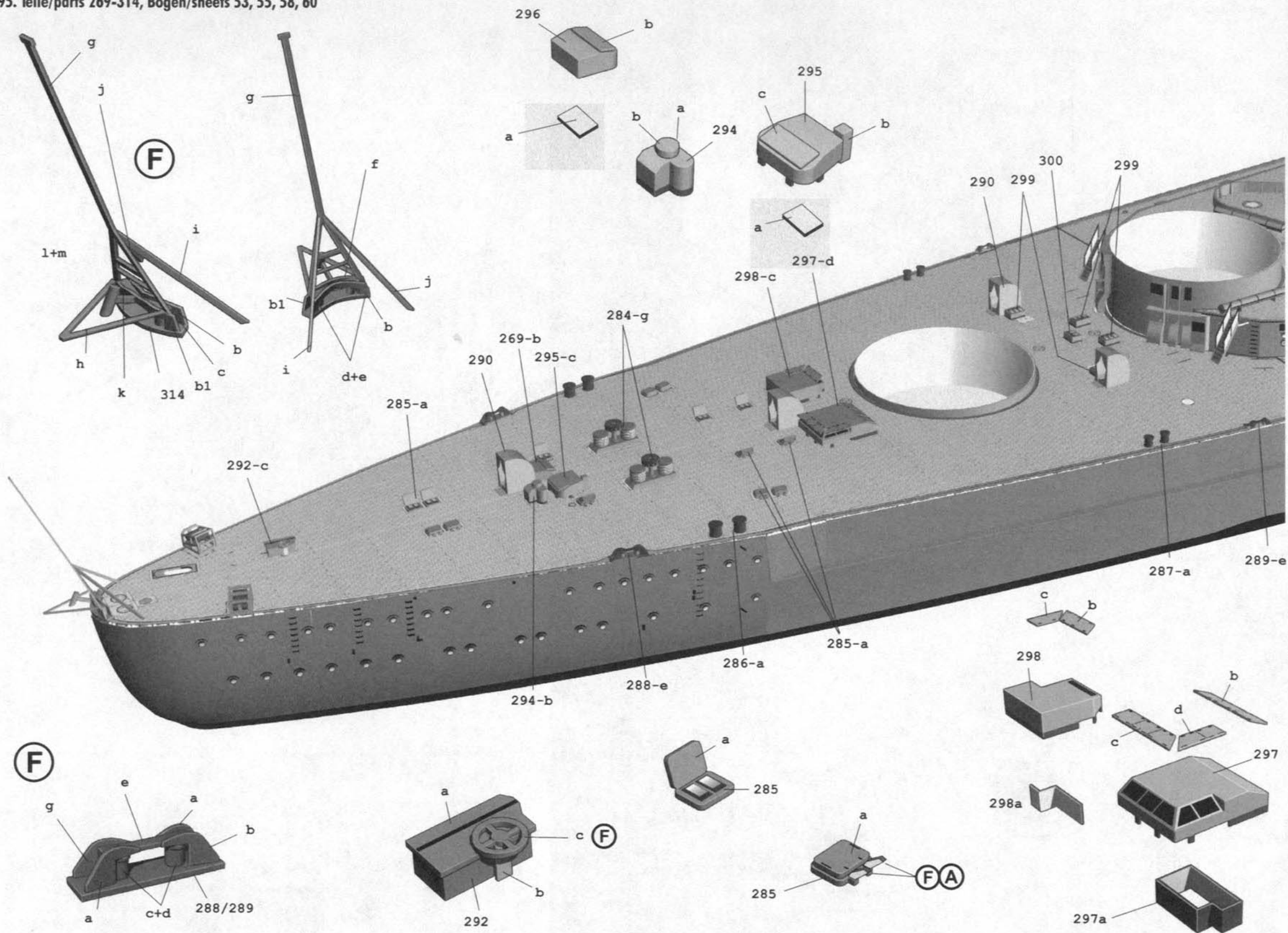

Zur Entstehung dieses Modells:

Das Schlachtschiff Bismarck faszinierte mich schon von Jugend an und ich baute natürlich einige Bismarck-Kartonmodelle. Zum Teil wurden diese auch schon „gesupert“ so gut es ging (mit gelöteter Draht-Reling). Gern hätte ich auch an Rumpf und Aufbauten weiter detailliert, aber mangels Unterlagen war es mir damals nicht möglich. Das änderte sich, als ich 1968 in meiner Bundesmarine-Dienstzeit während einer Werftfliegezeit bei Blohm + Voss einen der Überlebenden der Bismarck kennenlernte und Gelegenheit hatte, das Bismarck-Werftmodell zu besichtigen.

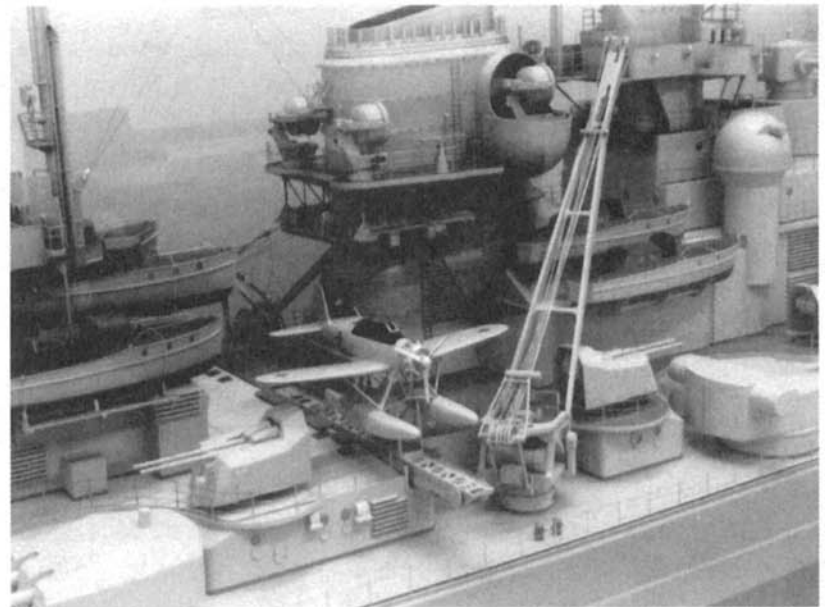

Blohm + Voss-Werftmodell der Bismarck im Maßstab 1:50

Beim genaueren Planstudium stellt sich die Frage: Wie kommt die Arado 196 beim Katapultstart am Kran vorbei? Hier ist die Lösung: Die hintere Rollenhalterung des Krans wird mit den Hydraulikzylindern nach unten gefahren. Der auf der Rollenhalterung angebrachte Bügel drückt zusätzlich die Seile nach unten. In der Bauanleitung unseres HMV-Modells ist der Kran in der normalen Betriebsstellung dargestellt.

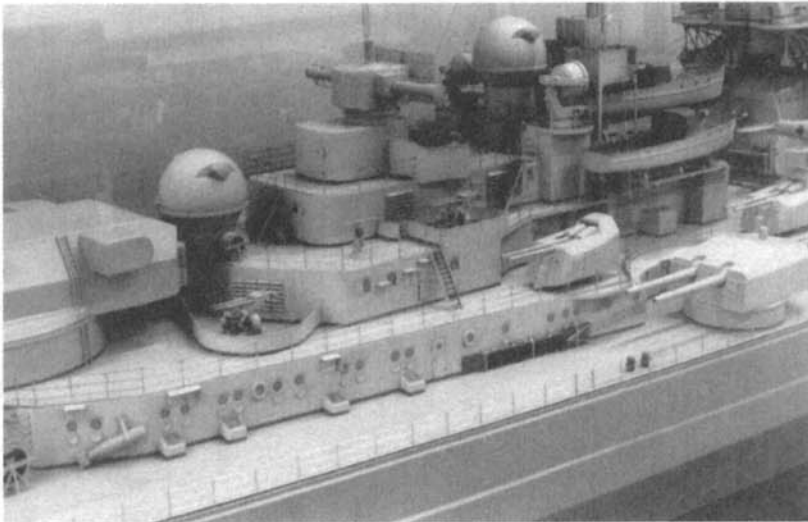

Blohm + Voss-Werftmodell der Bismarck im Maßstab 1:50

Blick auf den hinteren Aufbau. Hier sieht man die beiden hinteren „Wackeltöpfe“ - kardanisch aufgehängte Flak-Entfernungsmesser mit Schutzhälbkugeln, die hier vorgesehen waren, aber nicht eingebaut wurden. Stattdessen wurden die Entfernungsmesser in offenen Ständen untergebracht.

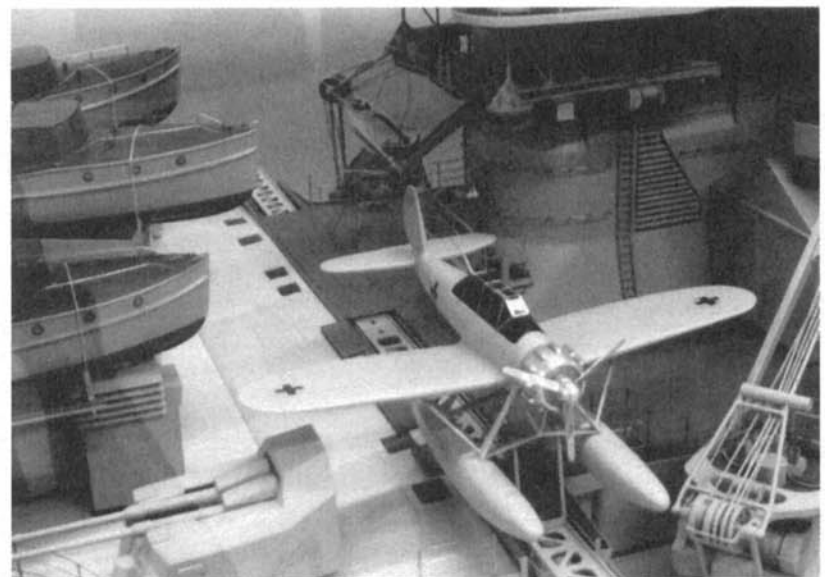

Blohm + Voss-Werftmodell der Bismarck im Maßstab 1:50

Hier ist die Arado 196 startbereit auf dem Katapult im Detail zu sehen.

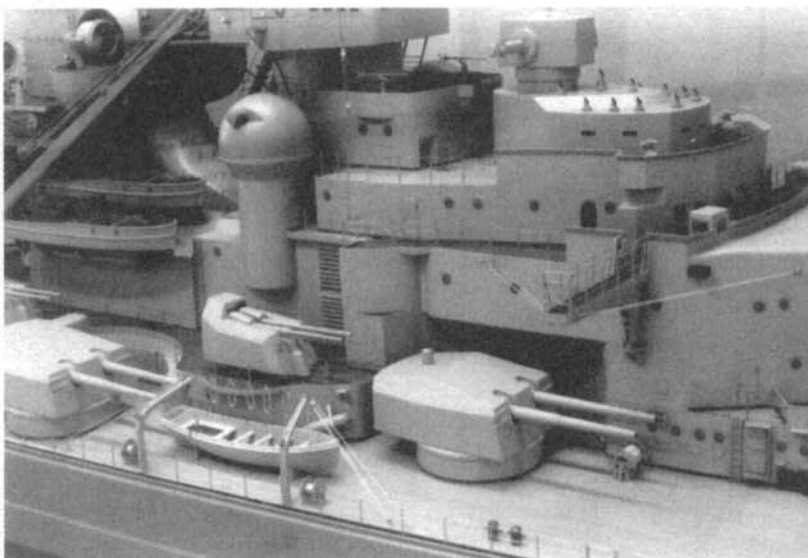

Blohm + Voss-Werftmodell der Bismarck im Maßstab 1:50

Blick auf den Brückenaufbau. Zu sehen sind die auch im Original eingebauten „Wackeltöpfe“, ein Bereitschaftskutter und die vorgesehene (aber hier nie eingebaute) 10,5 cm-Flak C37. Eingebaut wurde hier schließlich die ältere Version C31 und später vier C37-Versionen im Bereich des hinteren Aufbaus.

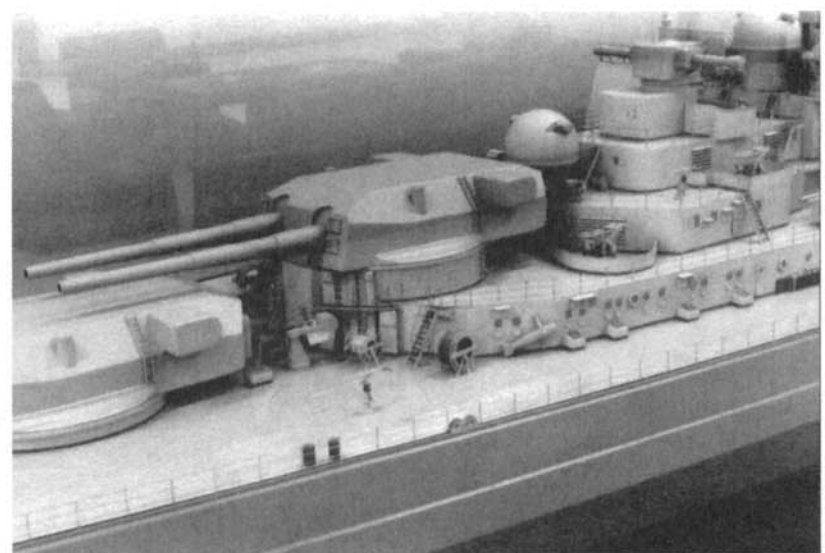

Blohm + Voss-Werftmodell der Bismarck im Maßstab 1:50

Hier sieht man zwischen den Türmen „Cäsar“ und „Dora“ die Ladeübungskanonen, die zum dargestellten Zeitpunkt unseres HMV-Modells bereits wieder entfernt worden waren.



Blohm + Voss-Werftmodell der Bismarck im Maßstab 1:50 Bug mit Buganker.

Dieses Modell entstand während der Bauzeit des Vorbildes bei Blohm + Voss und ist im Maßstab 1:50 ganze 5,02 m lang. Es zeigt den geplanten Indienstellungszustand und weicht daher in einigen Details von dem fertiggestellten Schiff ab. Das Modell bot dennoch viele aufschlußreiche

Ansichten, wie mir Originalfotos später bestätigten. So wurde meine Faszination wieder geweckt und der Traum eines von mir konstruierten Bismarck-Modells mit allen Details begann zu reifen.

Seit 1975 konstruierte ich viele Kartonmodelle für unterschiedliche Auftraggeber, aber für die Bismarck fand sich (noch) niemand bereit, den erheblichen finanziellen Aufwand einer Neukonstruktion zu übernehmen. Es blieb vorerst beim Materialsammeln, wobei mir der Kontakt zu weiteren der 115 Überlebenden eine große Hilfe war.

Nachdem ich einige Modelle für den Hamburger Modellbaubogen Verlag konstruiert hatte, fiel 1998 endlich der Startschuß für mein Traummodell der Bismarck in HMV-üblicher High-end-Qualität. Inzwischen war ein sehr gut rekonstruierter Plan von Hans Gally erschienen, den ich für die Konstruktion zugrunde legte.

Während ihrer kurzen Lebenszeit hatte die Bismarck einige Änderungen in der Ausrüstung erfahren. Zum Zeitpunkt der Indienstellung waren noch gar nicht alle Ausrüstungsgegenstände an Bord. Die zur Verfügung stehenden Unterlagen (hauptsächlich o. g. Plan und Fotos) stellten daher sehr unterschiedliche Bauzustände dar. Für das HMV-Modell wählte ich den Bauzustand Mai 1941, kurz vor dem Beginn des ersten und einzigen Einsatzes der Bismarck. Hier war das Schiff halbwegs vollständig und die Unterlagen hierüber ausreichend.

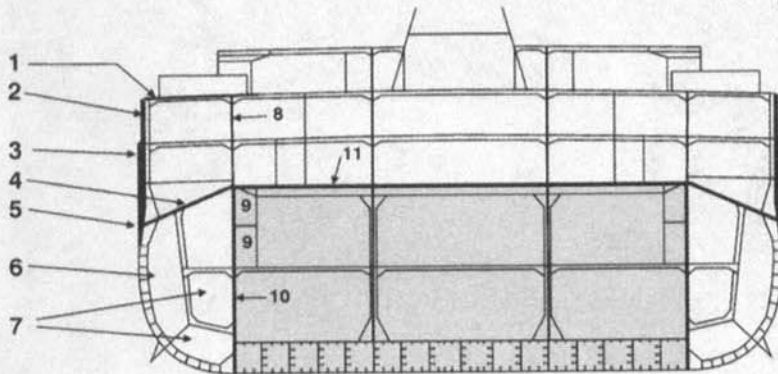

oben: Querschnitt durch den Hauptpanzer

1. Oberdeck 50 mm Wh (Wotan hart) geschweißt, neben den Türmen 80 mm
2. Zitadellpanzer 145 mm KCnA, genietet
3. Seitenpanzer 320 mm KCnA, genietet
4. Panzerdecksböschung 110 mm Wh, genietet
5. Seitenpanzer getäpelter Teil, im Mittel 170 mm KCnA, genietet
6. Leerraum
7. Heizöl
8. Splitterlängsschott 30 mm Wh
9. Kabelgänge
10. Torpedoschott 45 mm Ww (Wotan weich), genietet
11. Panzerdeck 80 mm Wh, genietet

rechts: Längsschnitt durch das Schiff mit Antriebsanlage und Angaben der Panzerstärken in mm

1. E-Werk 1
2. E-Werk 2
3. Turbinenraum mittschiffs
4. Turbinenraum Backbord
5. Turbinenraum Steuerbord
6. Kesselraum Backbord 1
7. Kesselraum Mitte 1
8. Kesselraum Steuerbord 1
9. Kesselraum Backbord 2
10. Kesselraum Mitte 2
11. Kesselraum Steuerbord 2
12. E-Werk 3
13. Hilfskesselraum
14. E-Werk 4

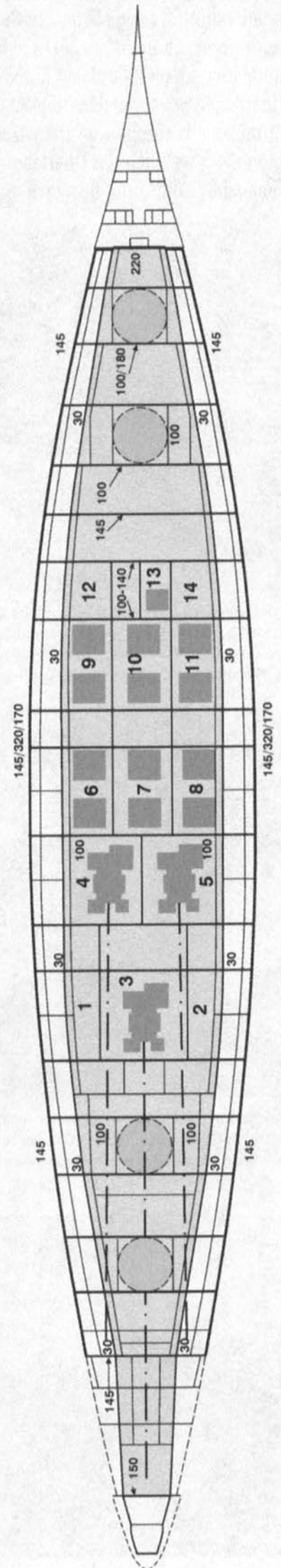
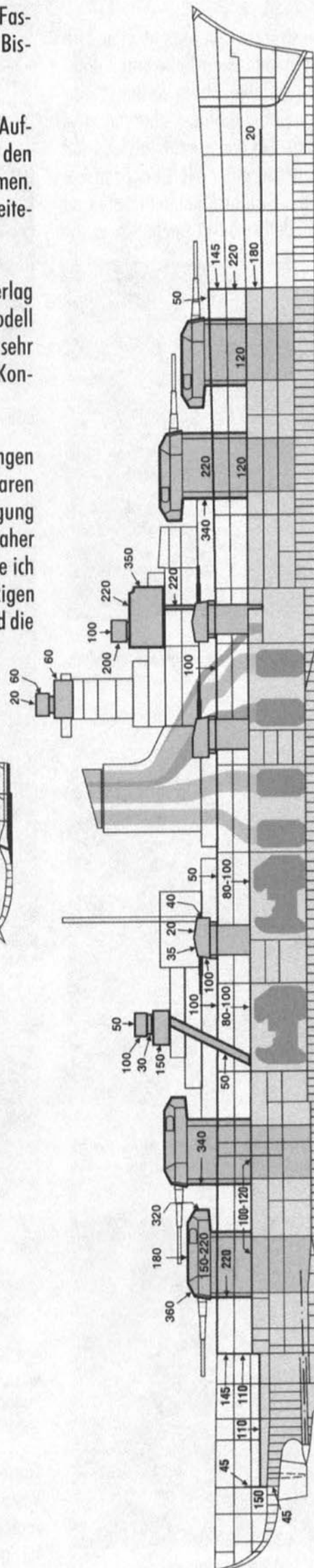

Das Modell sollte einen wahlweise baubaren Unterwasserteil erhalten, damit es sowohl als Standmodell nach Museumsart oder für ein Diorama als Wasserlinienmodell verwendbar ist. Auf eine Tarnbemalung habe ich verzichtet, da sie bereits während des Aufenthaltes in Norwegen bis auf die aufgemalte Bugwelle am Vorschiff wieder entfernt wurde. Auf die Darstellung der Fliegererkennungszeichen auf Back und Schanz und die Kriegsflagge mußte aus rechtlichen Gründen verzichtet werden.

Während der Konstruktionszeit lernte ich auf den Hamburger Modellbautagen 1999 Herrn Josef Kaiser kennen. Er baut seit ca. 20 Jahren an einem Bismarck-Modell im Maßstab 1:100. Es ist das beste Bismarck-Modell, das ich bisher gesehen habe und übertrifft in der Detaillierung selbst das Werftmodell im Maßstab 1:50. Da er ebenfalls den Bauzustand Mai '41 gewählt hatte, war ein Vergleich mit meinen Konstruktionsunterlagen möglich.

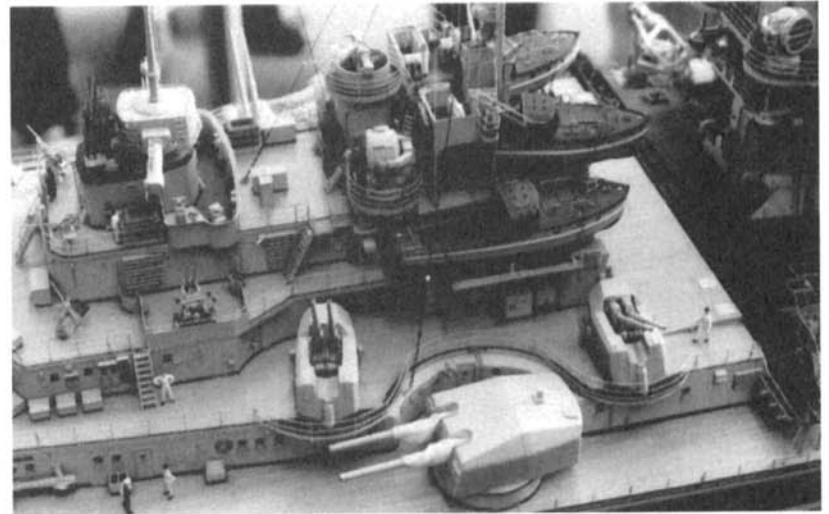

Bismarckmodell im Maßstab 1:100, Eigenbau von J. Kaiser
Hinterer Aufbau mit den neueren 10,5 cm-Flakgeschützen Version C37.

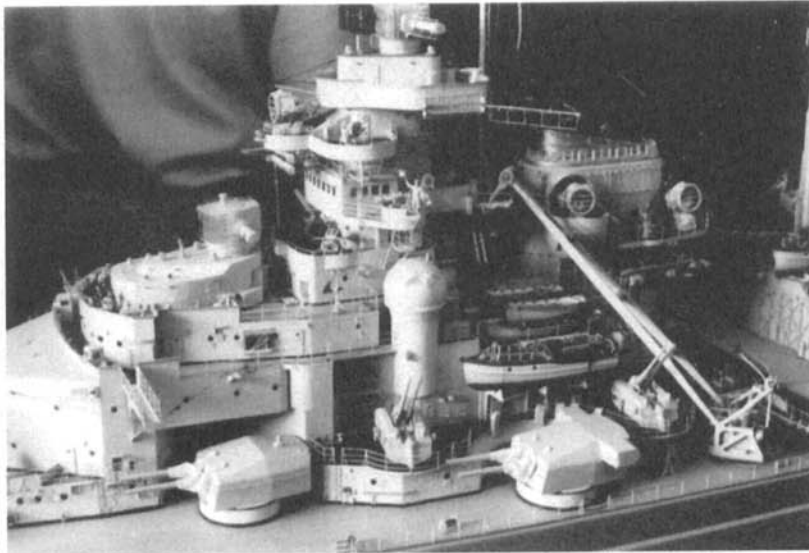

Bismarckmodell im Maßstab 1:100, Eigenbau von J. Kaiser
Der Brückenaufbau von der Backbordseite zeigt eindrucksvoll den hohen Detaillierungsgrad (einschließlich Besatzung!) - vielleicht eine Anregung zum „Supern“.



Bismarckmodell im Maßstab 1:100, Eigenbau von J. Kaiser
Der Brückenaufbau von der Steuerbordseite gesehen. Viele der Richtsäulen und anderer Geräte sind auch in HMV-Kartonmodell dargestellt. Hier ist es sehr ratsam, den Fotoatzsatz zur Bismarck zu verwenden!

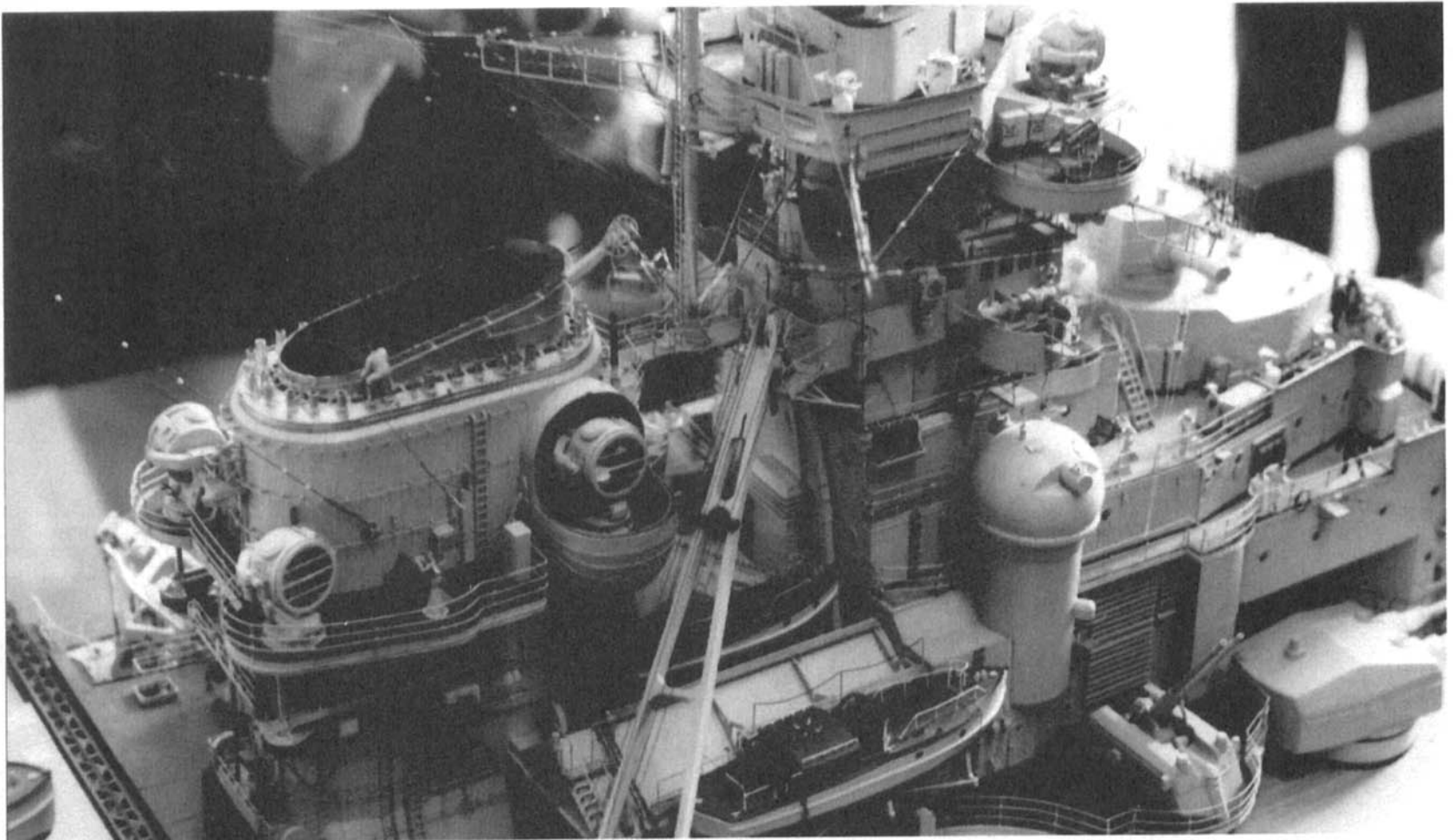

Bismarckmodell im Maßstab 1:100, Eigenbau von J. Kaiser
Brückenaufbau Steuerbordseite und Schornsteinbereich mit Scheinwerferplattform und Bootslagern. Zu sehen ist auch das hier eingebaute 10,5 cm-Flakgeschütz Typ C31.

Herr Kaiser stellt sein Modell auf vielen Modellbaumessen aus und gibt anderen Modellbauern gern Auskunft über die Arbeit an seinem Bismarckmodell. Nicht alles, was es am 1:100-Modell von Herrn Kaiser zu sehen gab und auf meinem 1:100-Plan eingezeichnet war, ist auf einem 1:250-Kartonmodell sinnvoll umzusetzen. Die abgebildeten Fotos seines Modells sollen dem detailverliebten Modellbauer als Anregung zum „Supern“ dienen. Die HMV-Bismarck ist für Kartonmodellbau-Profis gedacht, aber sie sollte dennoch für möglichst viele mutige Modellbauer baubar bleiben.

Insgesamt erstreckte sich die Arbeit an der Bismarck einschließlich Kontrollbau auf zwei Jahre, da hier der Teufel in sehr vielen Details steckte und außerdem interessante Informationen erst während der Konstruktionszeit zugänglich wurden. Zusammen mit dem dazu entwickelten Fotoätzsatz, der sogar strukturierte Flächen enthält, läßt sich (sicherlich mit einem ebenso hohen Zeitaufwand) aus diesem Bismarck-Bausatz ein Modell in Museumsqualität erstellen. Viel Spaß beim Bau!

Peter Brandt

Fotoätzsatz für das Schlachtschiff Bismarck:

Super Detail Set zum Verfeinern des Kartonmodells. Das Set besteht aus sechs Platinen aus 0,1 mm Neusilberblech von 19,5 x 14 cm Größe und enthält Reling, Decksflächen mit Struktur, Teile für Kräne, Katapulte, Bordflugzeuge, Flakgeschütze, Hangartore, Scheinwerfer, Seiltrommeln, Treppen und Leitern, Bootslager, Davits, Radargeräte und sämtliche Lüfterlamellen. Der Ätzsatz ist separat erhältlich. Fragen Sie Ihren Fachhändler oder wenden Sie sich direkt an den Hamburger Modellbaubogen Verlag.

