



**GOMIX**

®

**FLY MODEL**

„SURCOUF”

**139**

Model kartonowy

Skala 1:100

dł. 110,0 cm

szer. 9,0 cm

ISSN 1233-9423

# „SURCOUF”

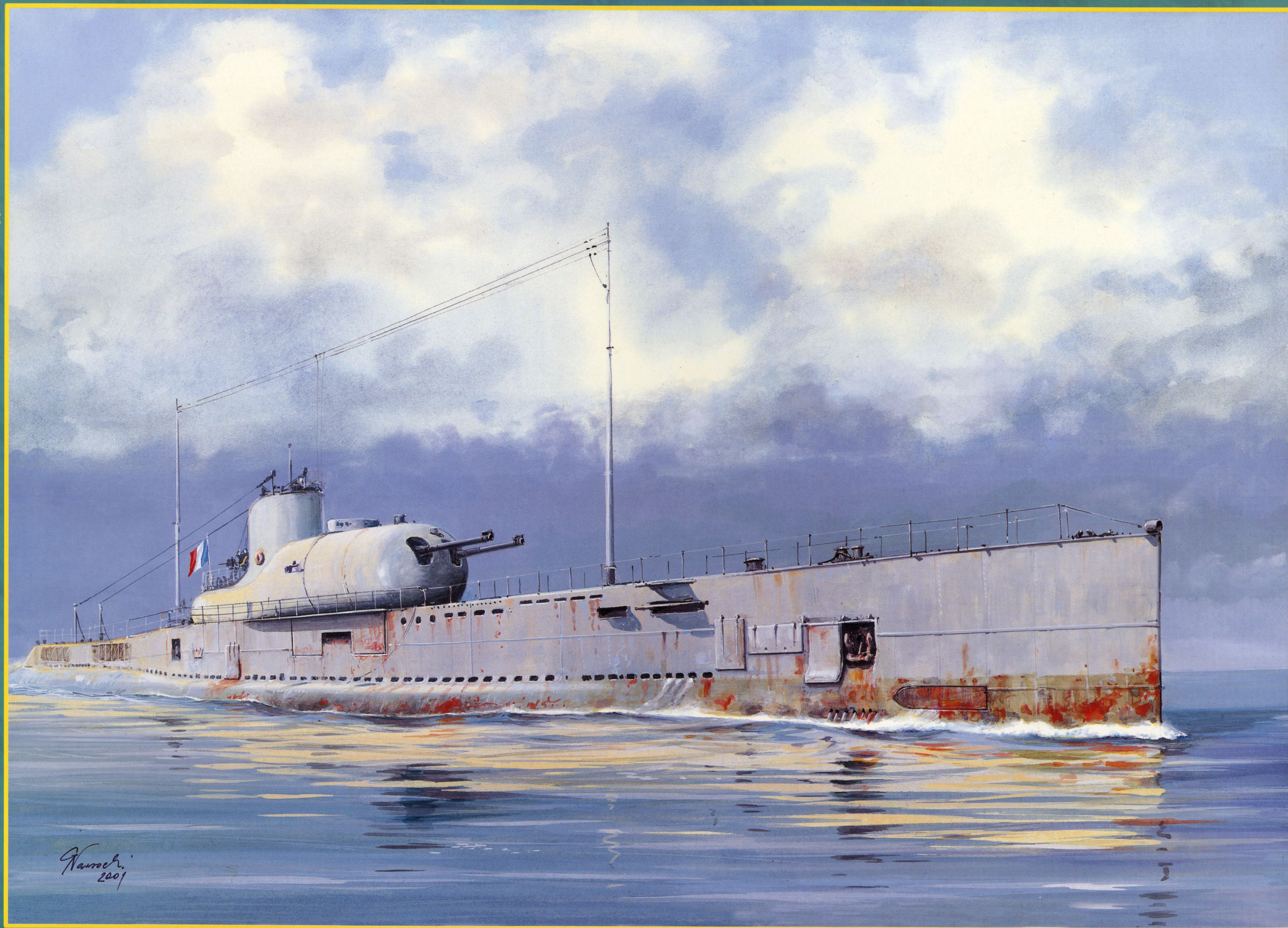

PLAN GENERALNY MODELU >SURKOUF<

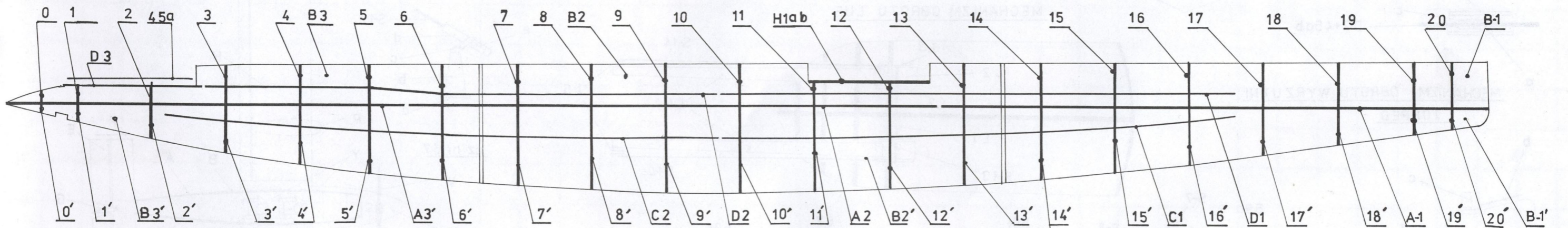
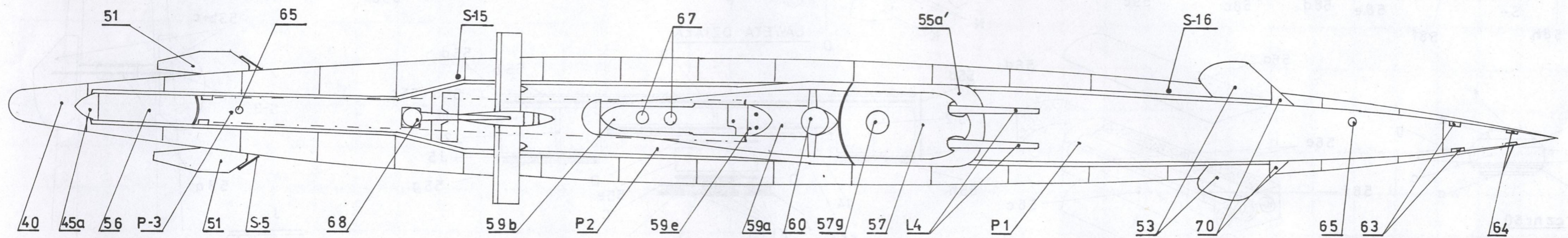
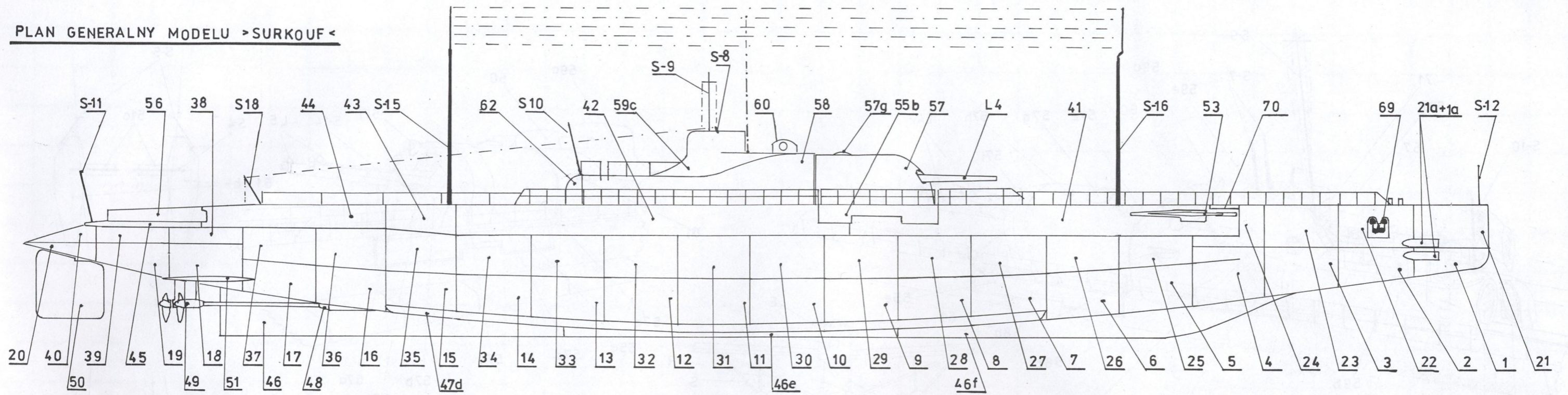

SZKIELET KIOSKU ORAZ OSŁONY DZIAŁ

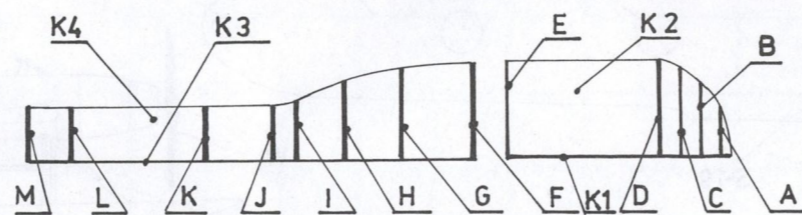



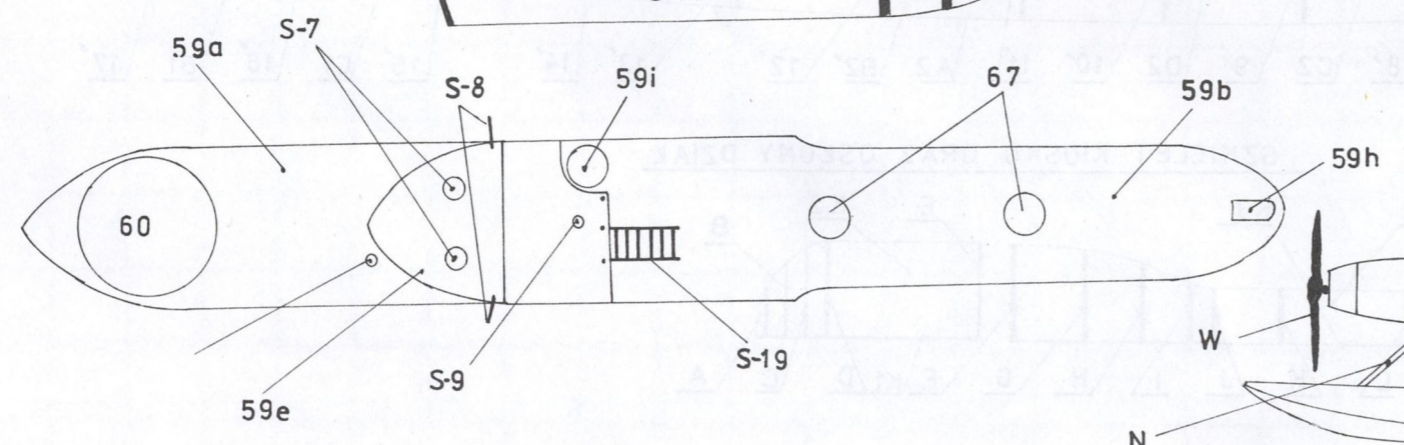
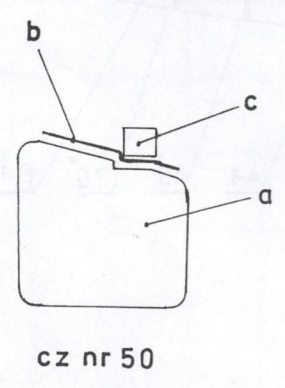
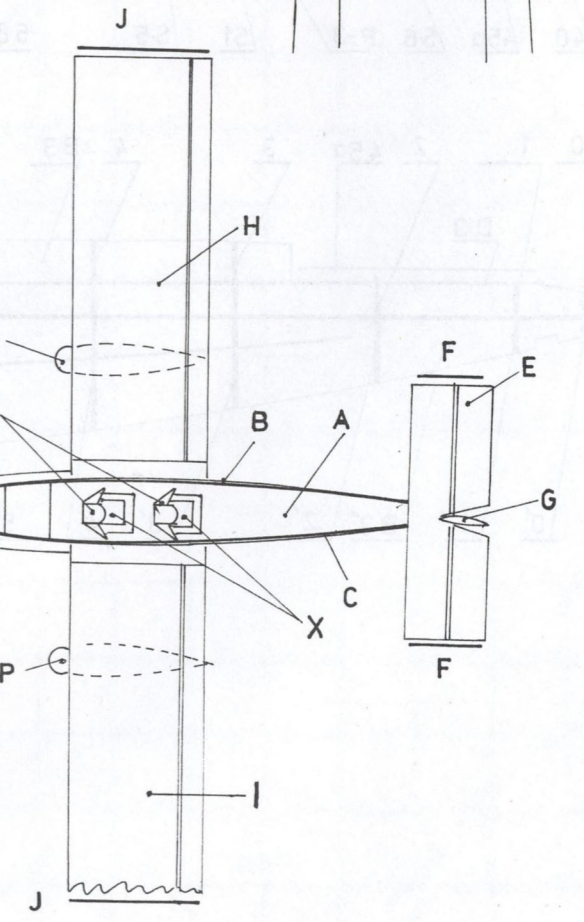
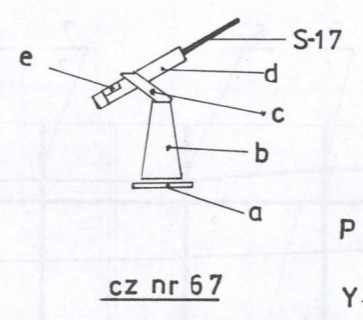
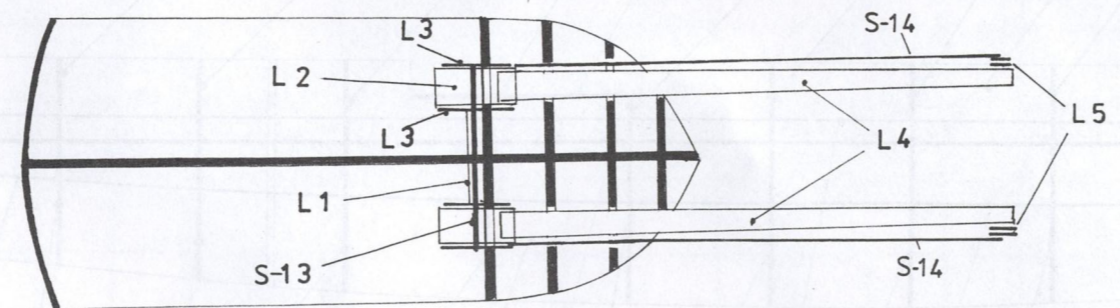
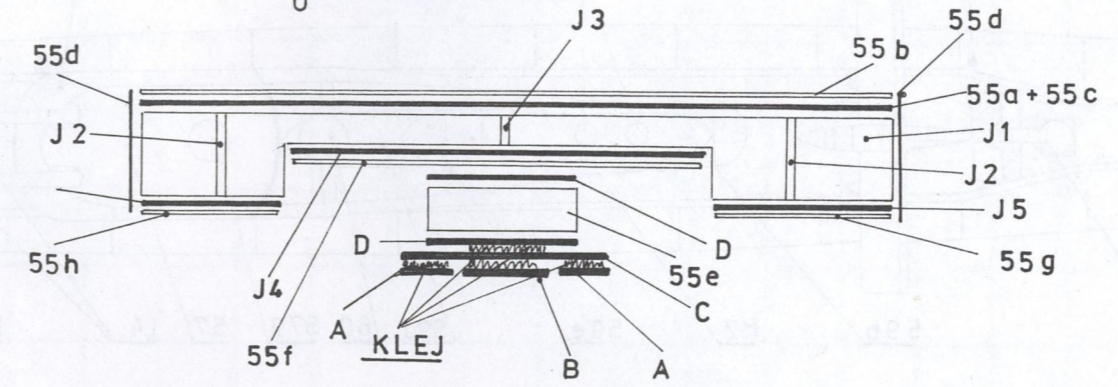
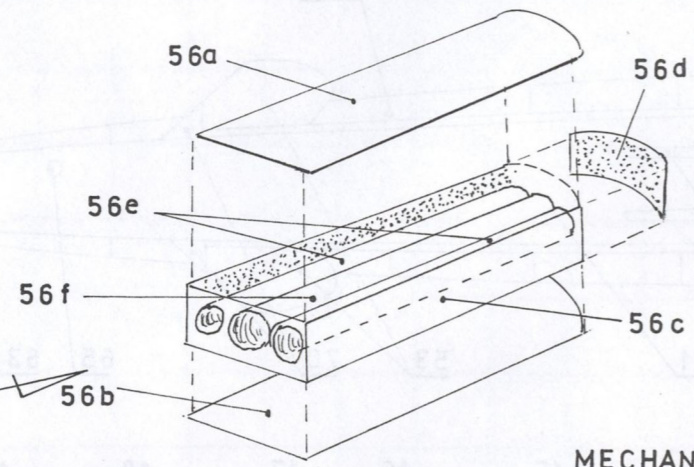
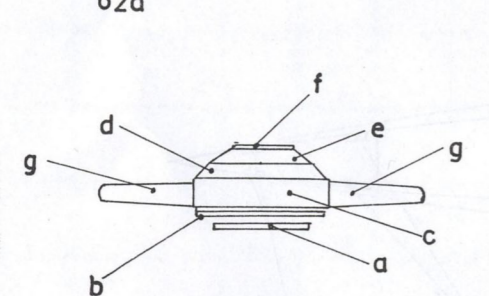
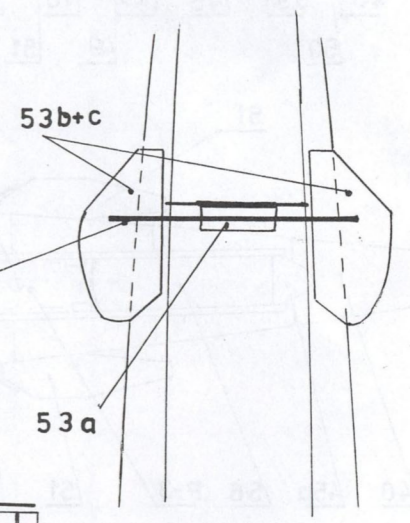
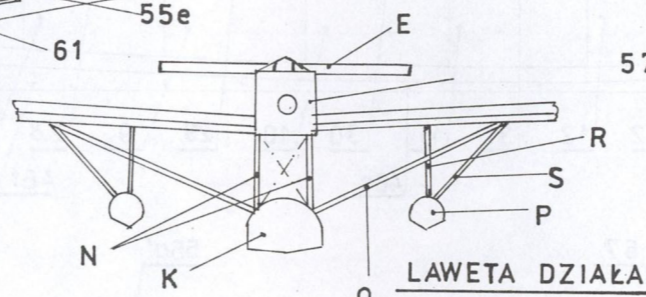
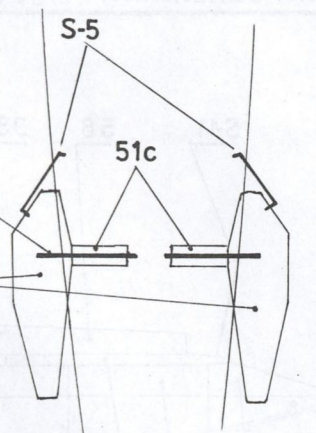
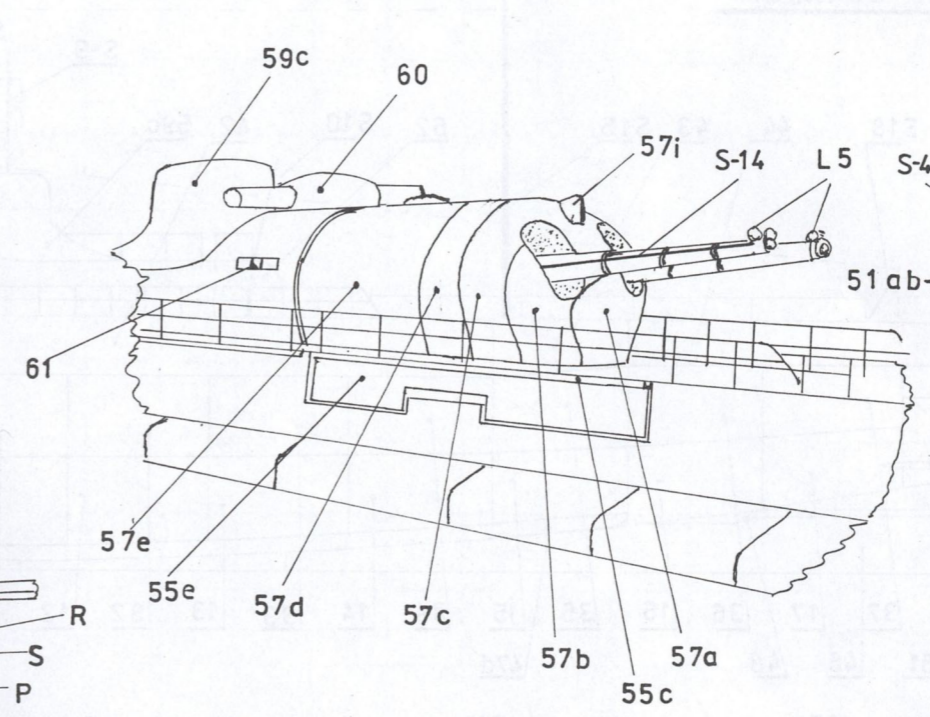
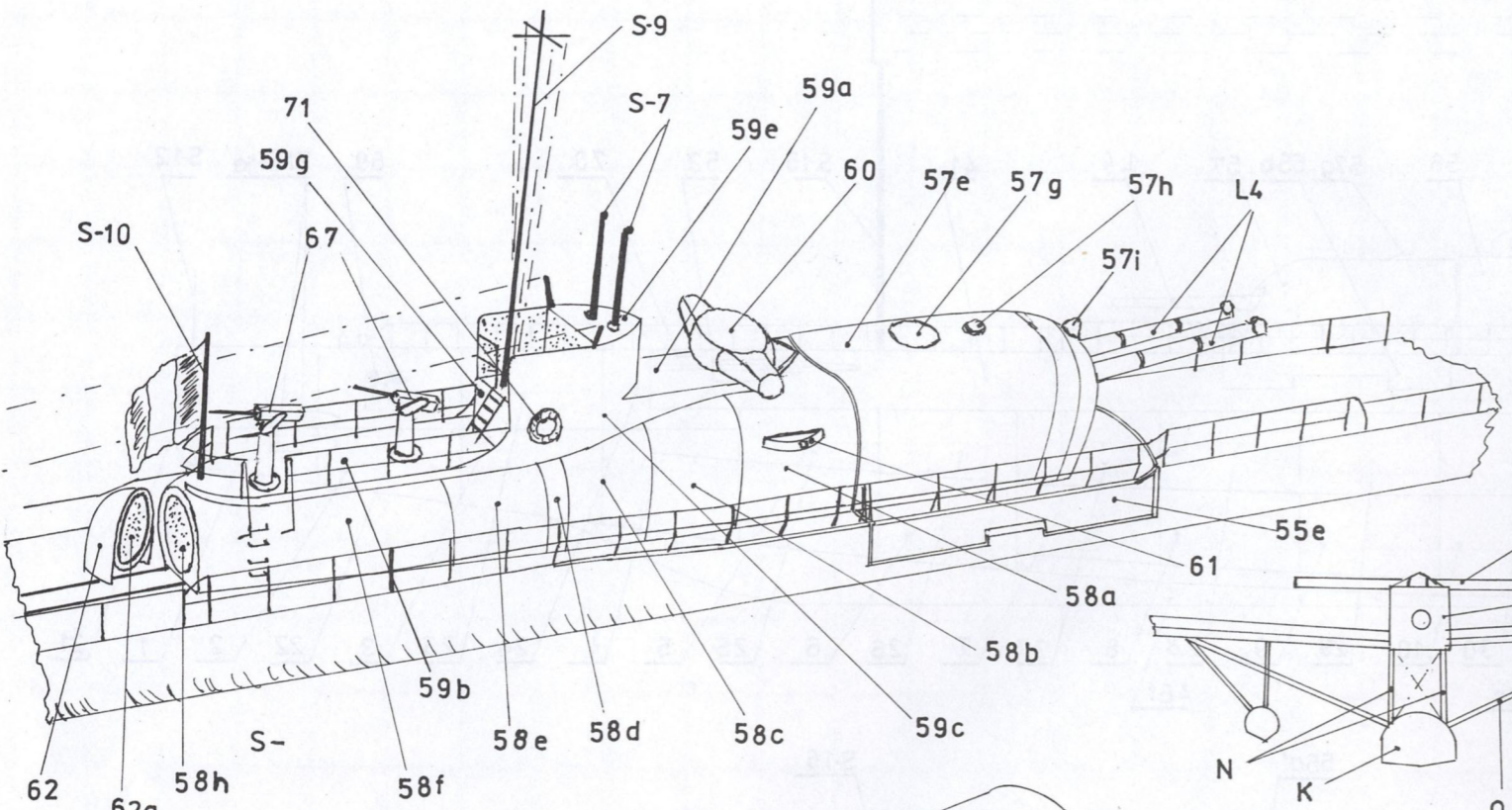

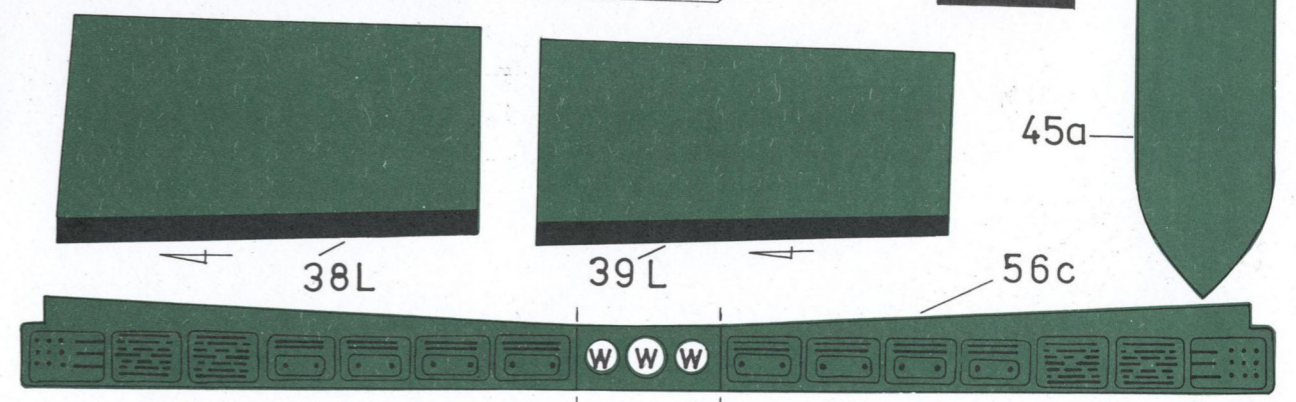
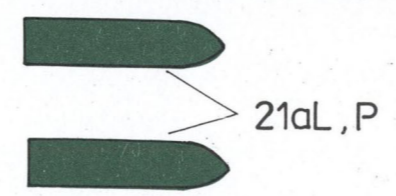
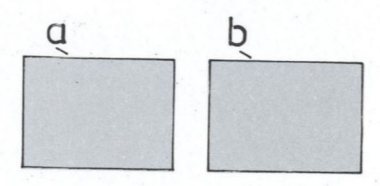
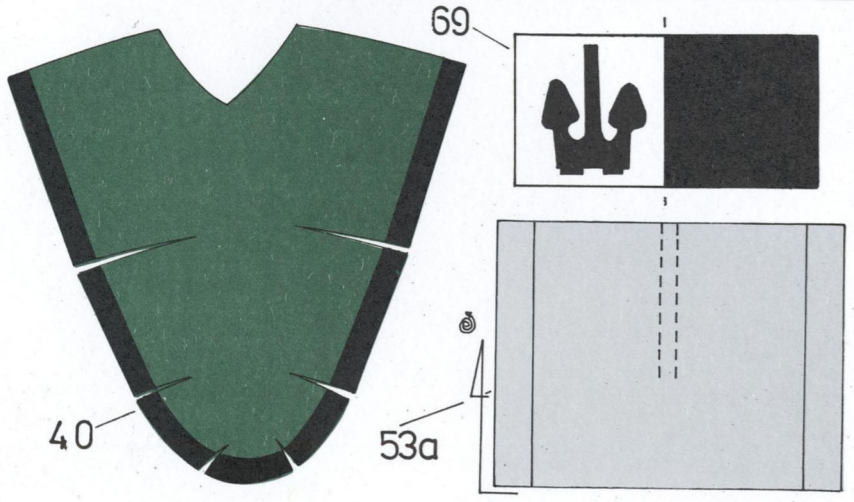
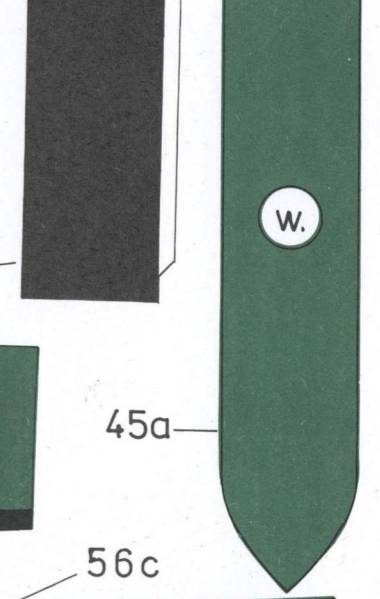
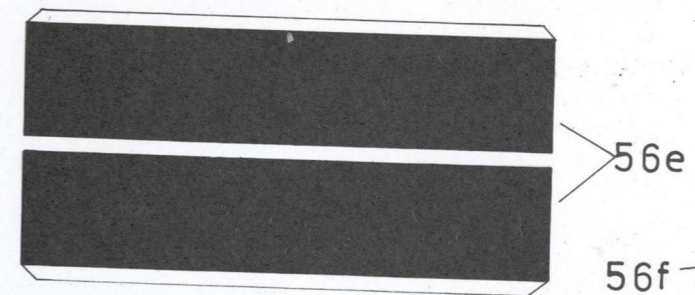
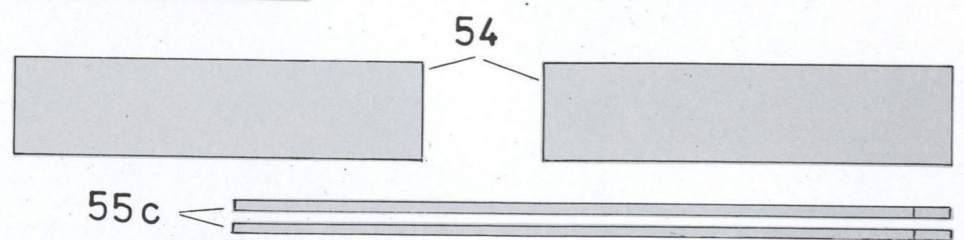
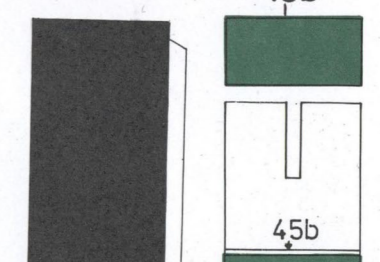
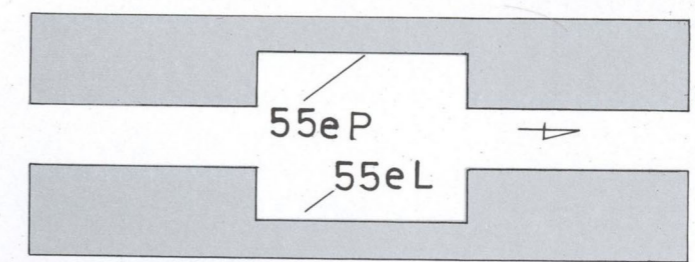
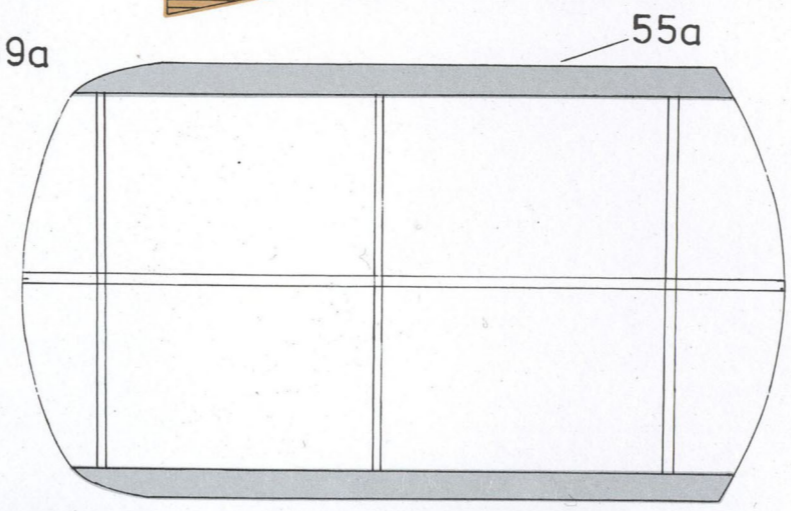
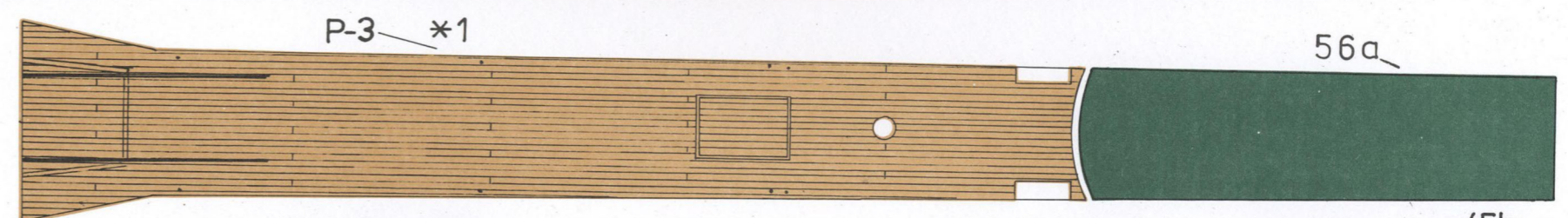
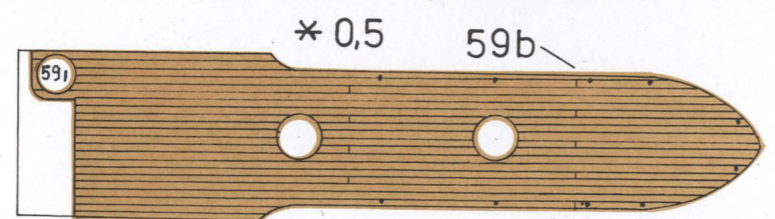
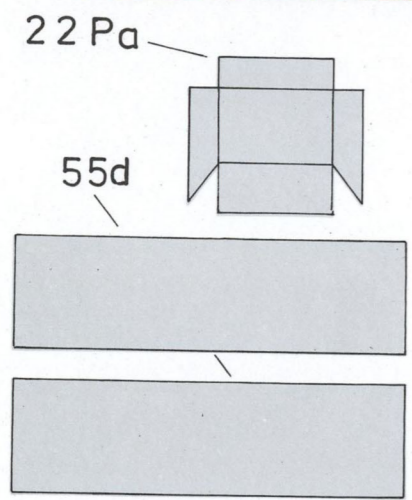
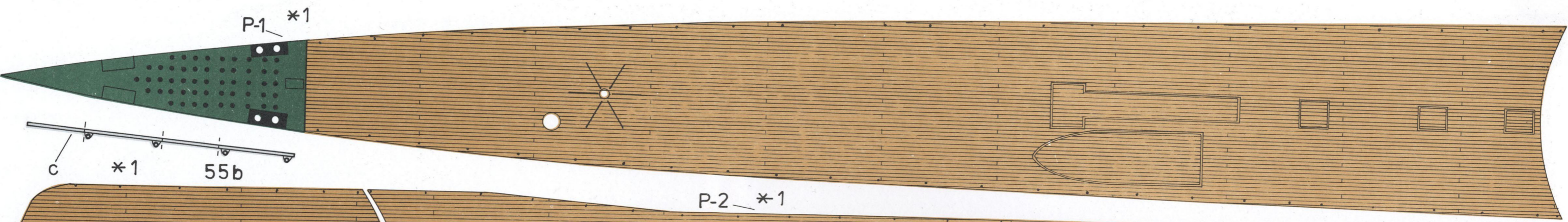

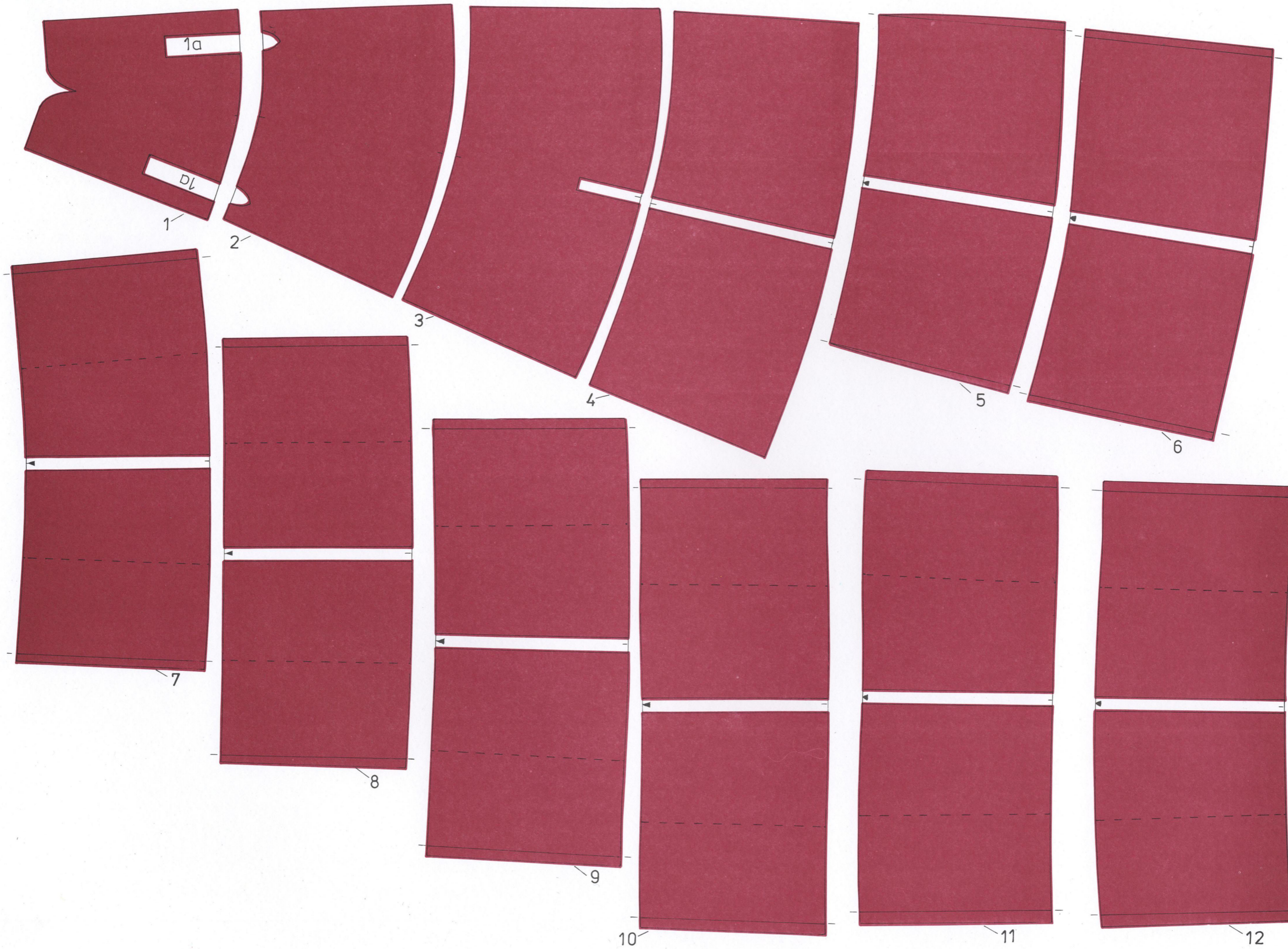

1a

DL

1

2

3

4

5

6

7

8

9

10

11

12



1a



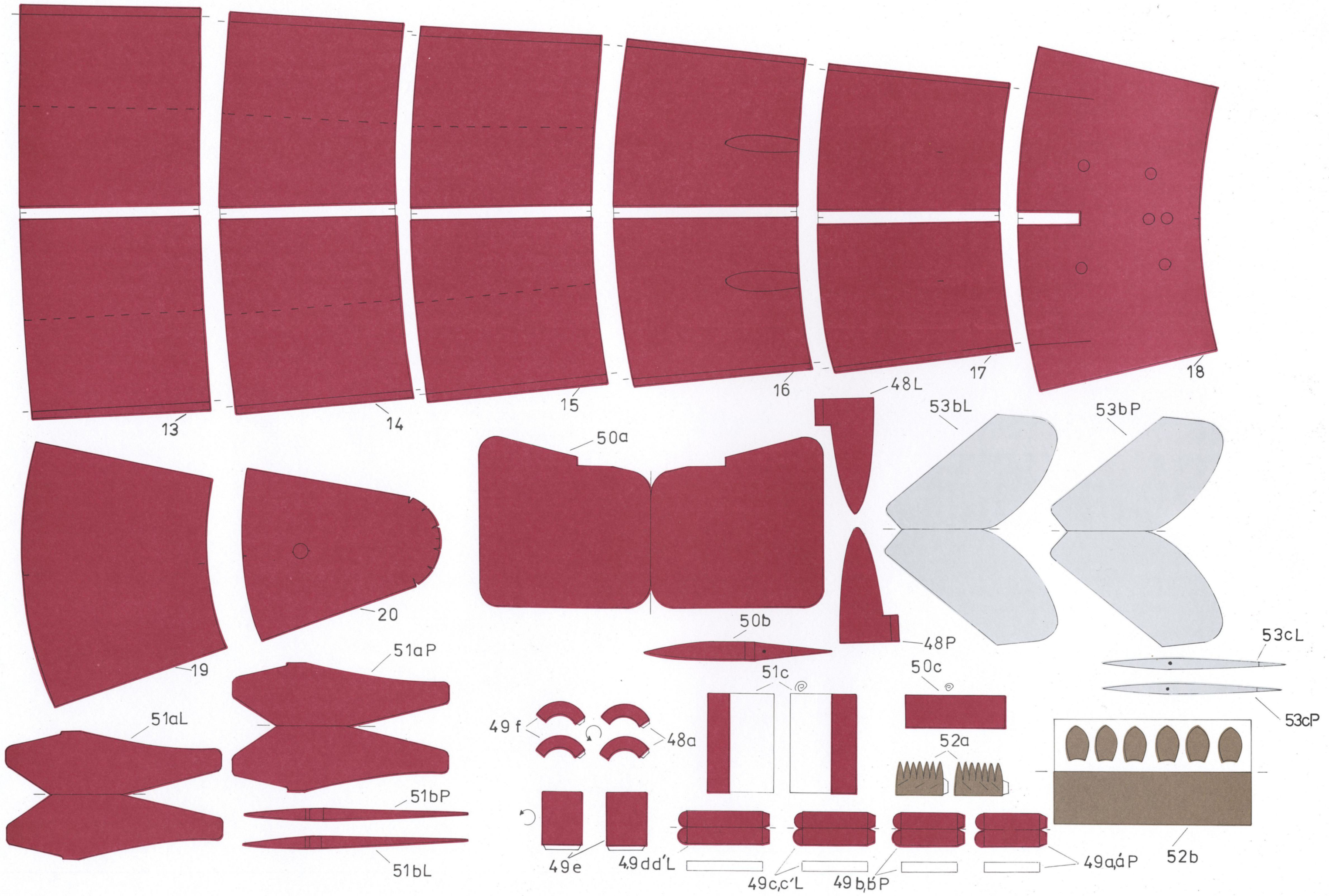

rufa

47L

dziób

47P

58h

68c

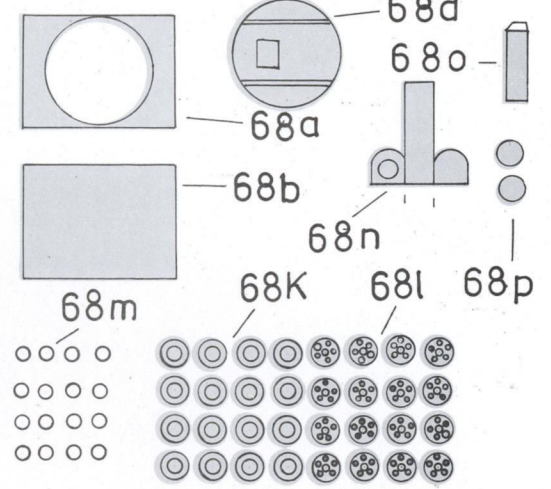

46dL

65

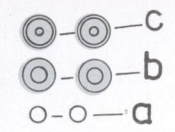

67a

67b

68j

68i

46dP

46eL

\*1

c

68g

68h

46fL

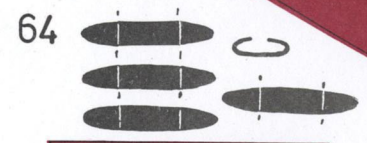

63b

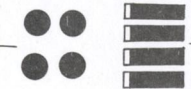

63a

46fP

46h



46eP

\*1

d

e

68

46g

\*1

67e

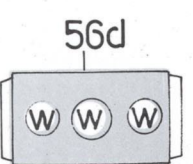
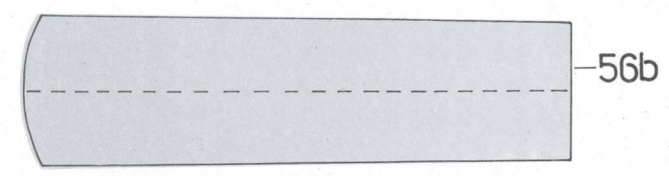



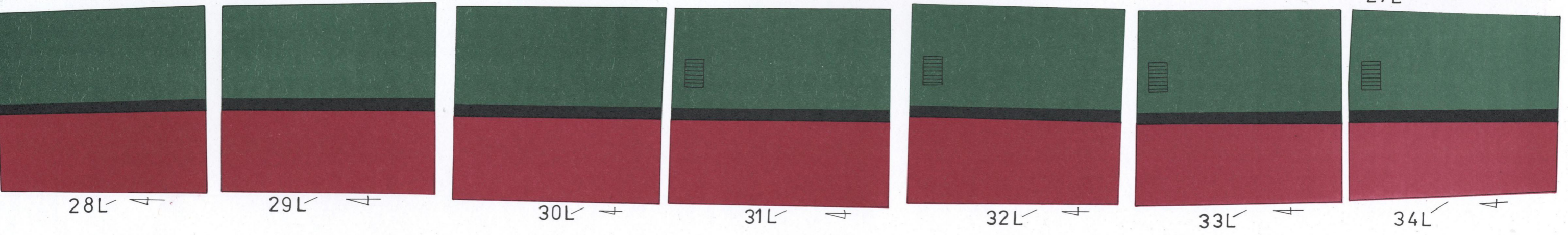
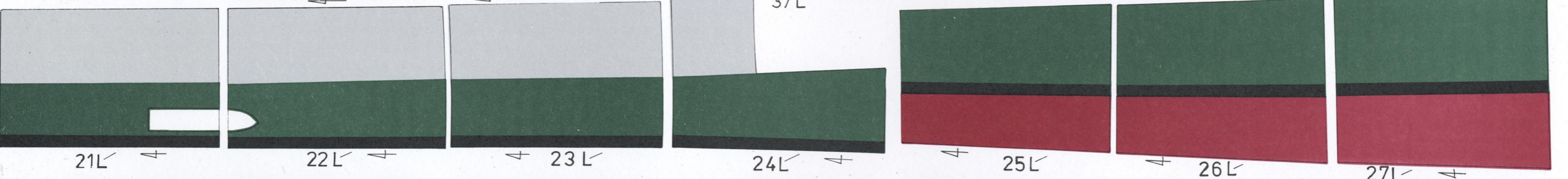
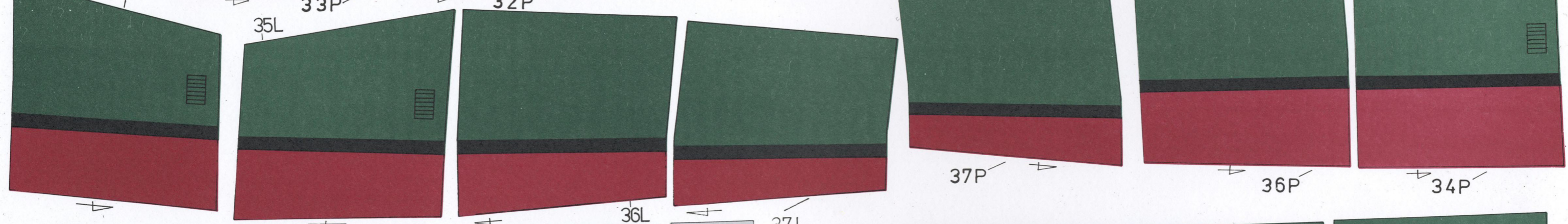
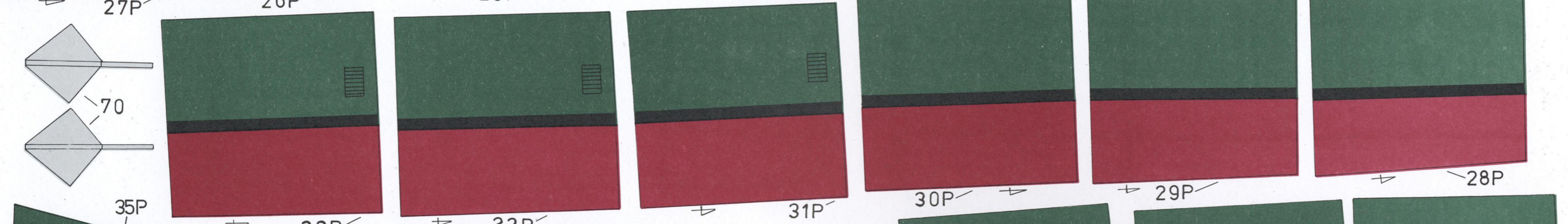
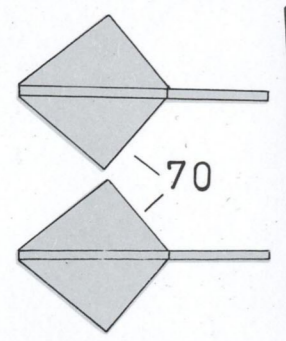
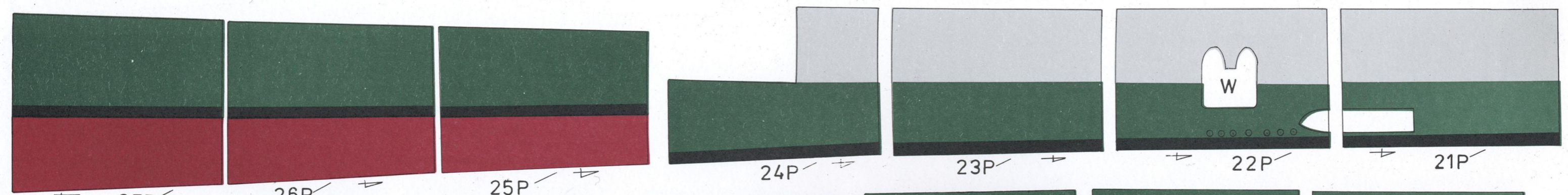

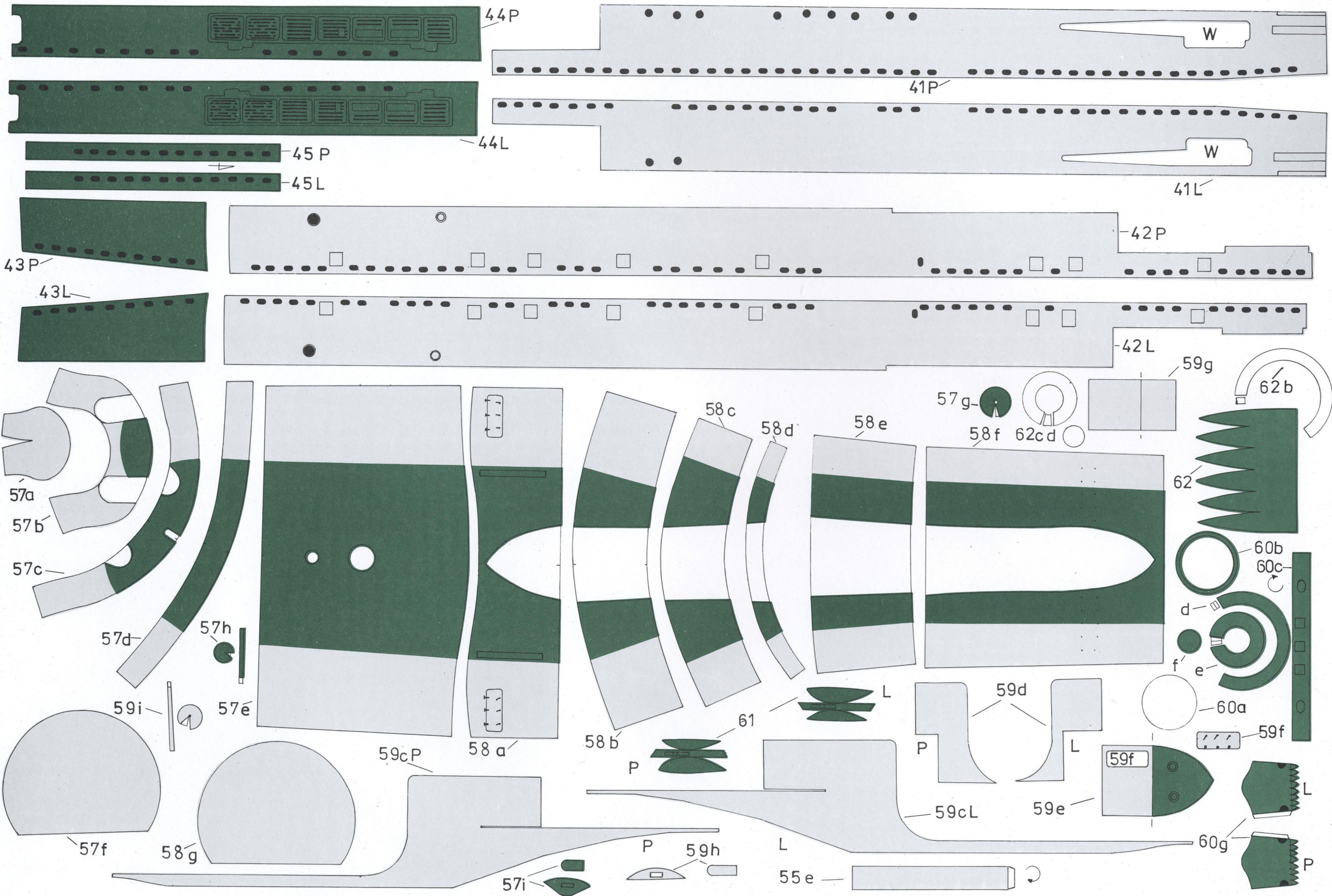

44P

W

41P

W

41L

45P

44L

45L

42P

43P

42L

43L

59g

62b

57g

58f

62cd

57a

57b

57c

62

60b

60c

57d

57h

57e

d

f

e

60a

59f

L

P

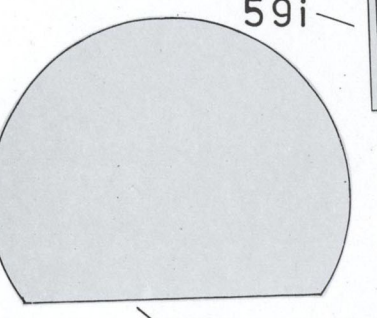

57f

58g

59cP

58a

58b

P

61

L

P

59d

L

59f

59cL

59e

60g

L

P

P

59h

L

55e

57i

W

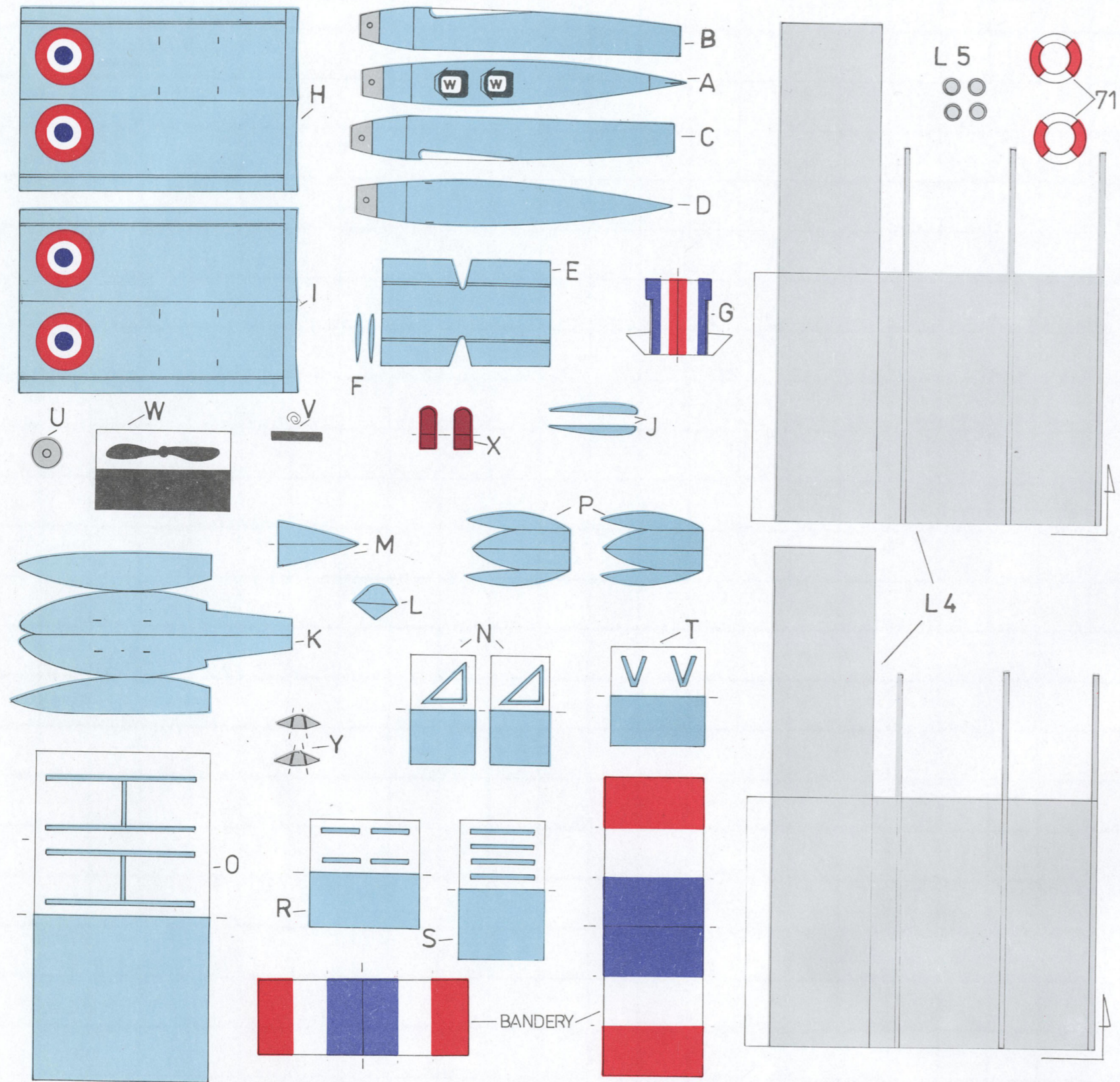

SZABLONY I ELEMENTY DO SAMODZIELNEGO WYKONANIA SKALA 1:1

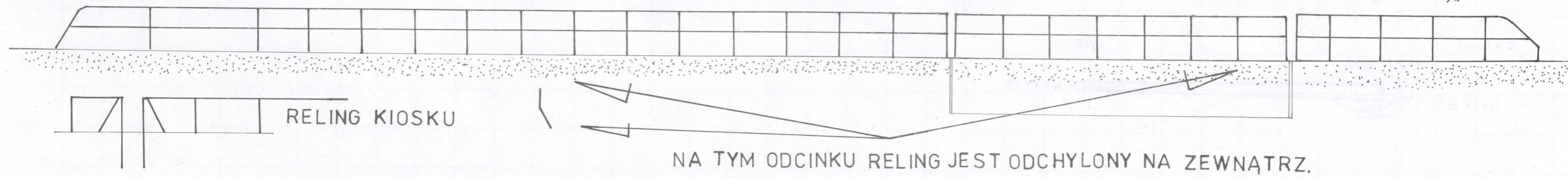
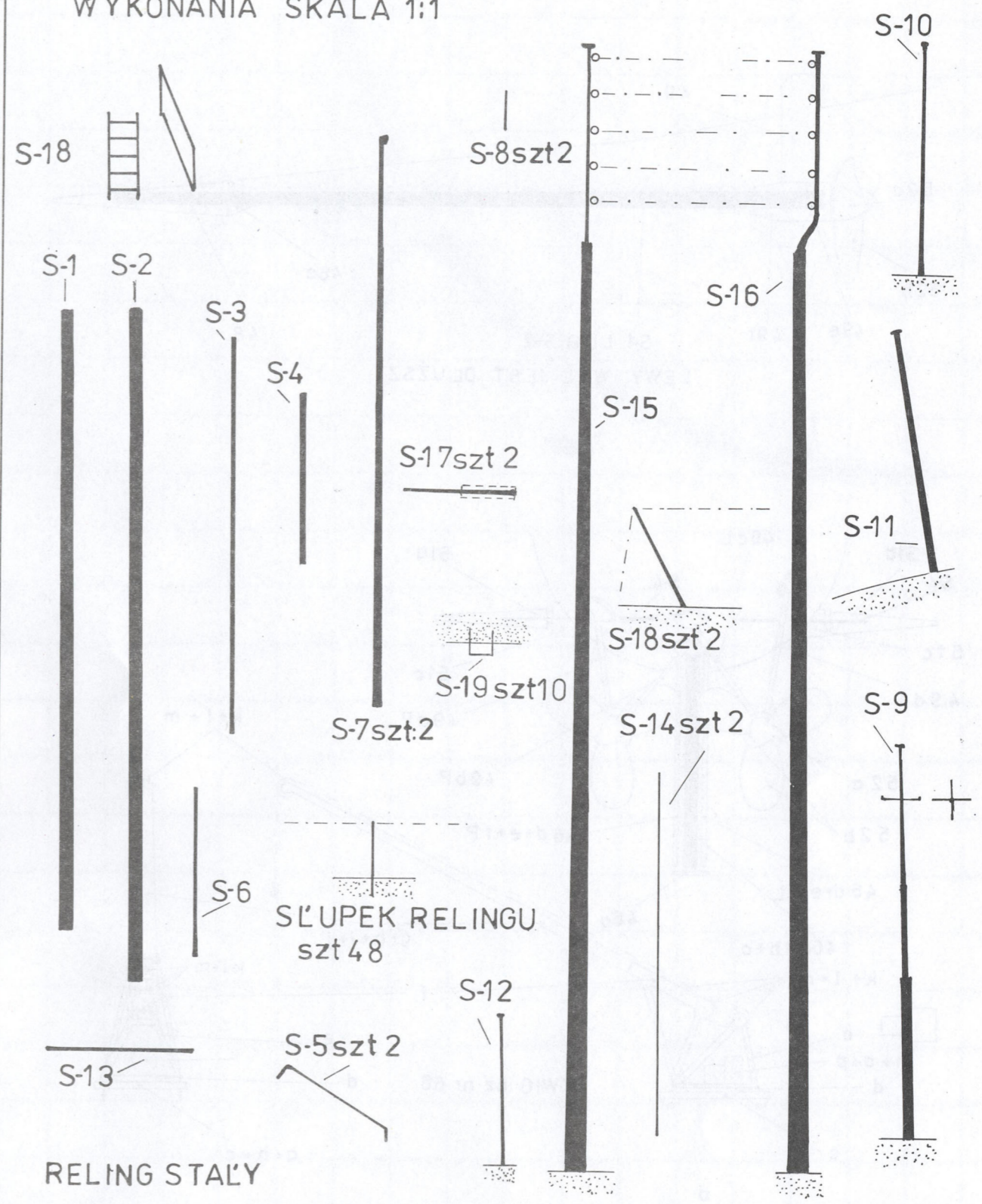

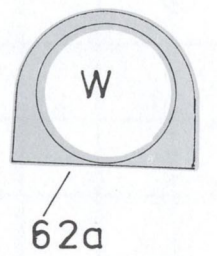
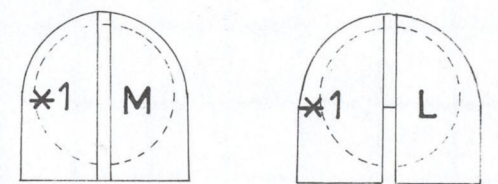
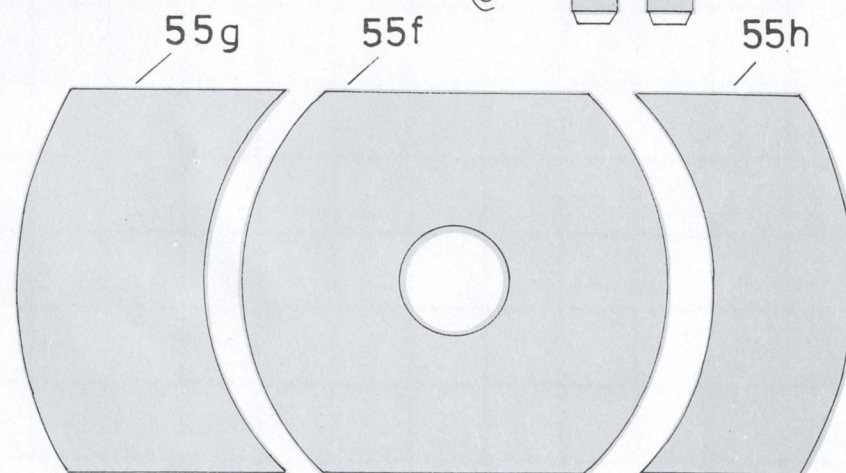
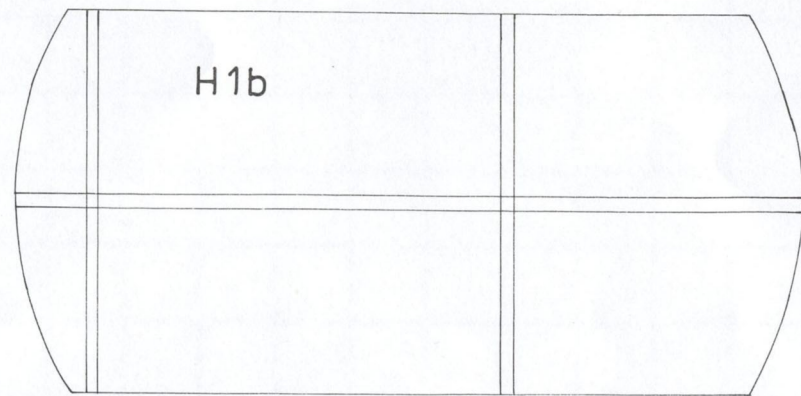
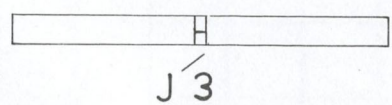
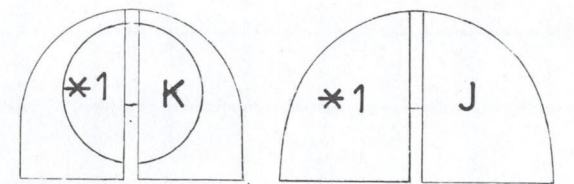
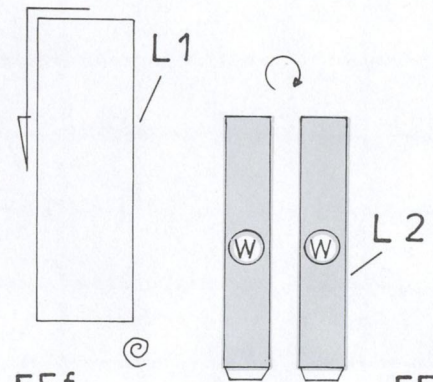
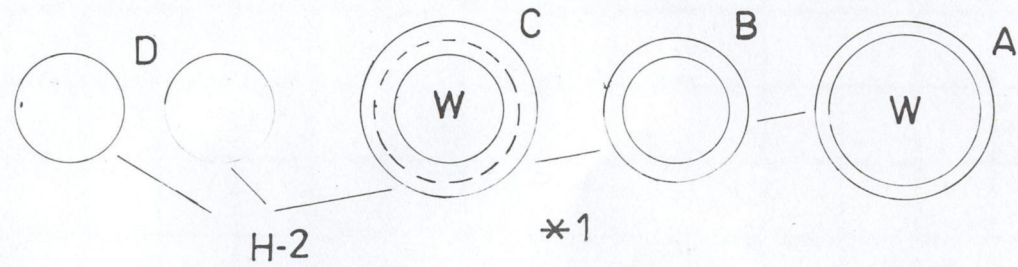
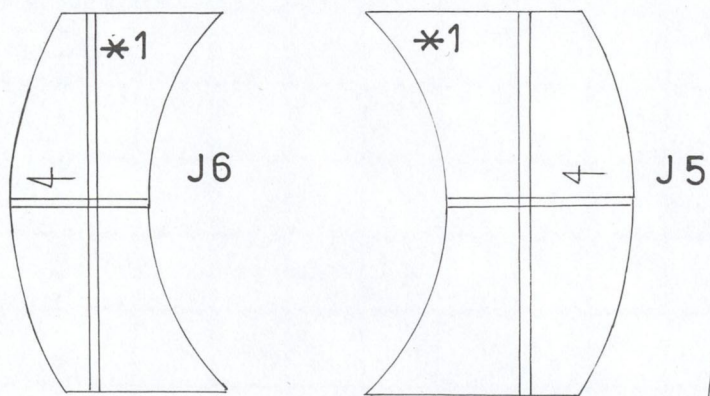
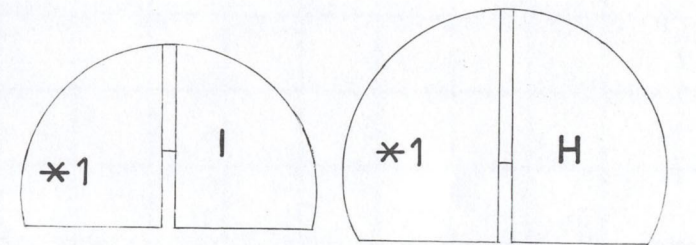
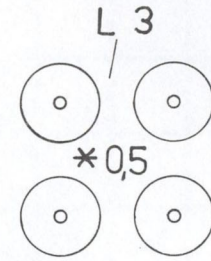
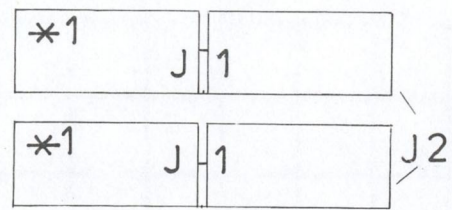
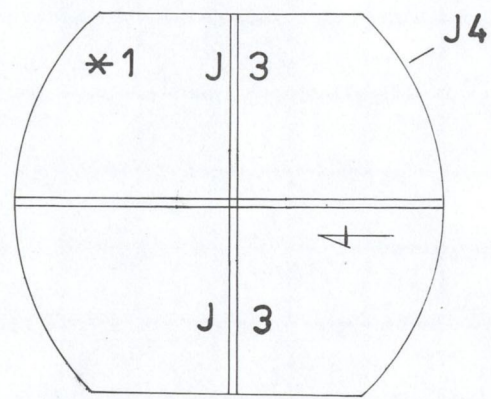
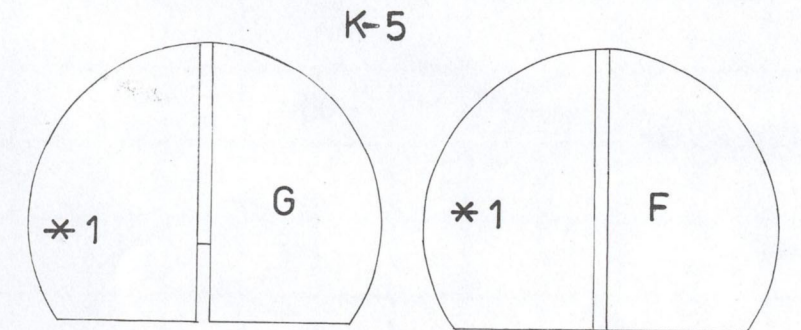
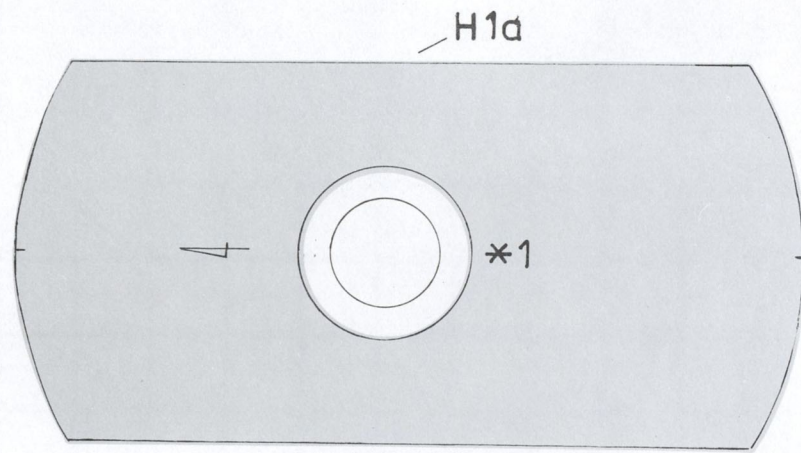
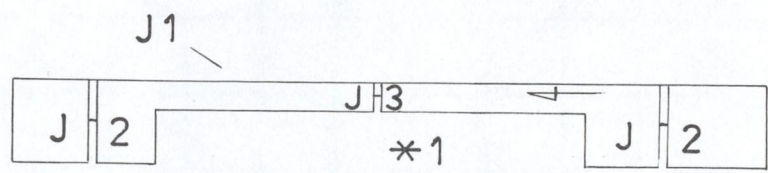
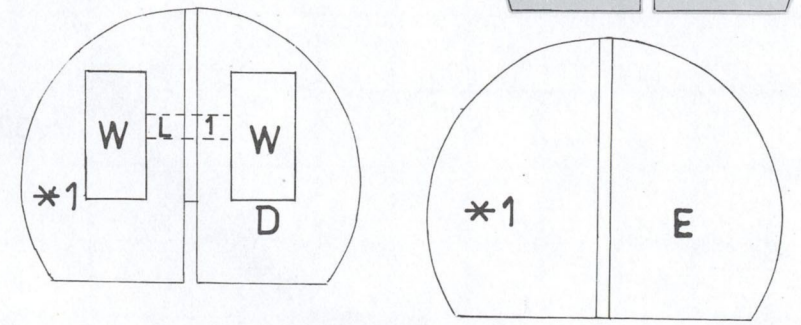
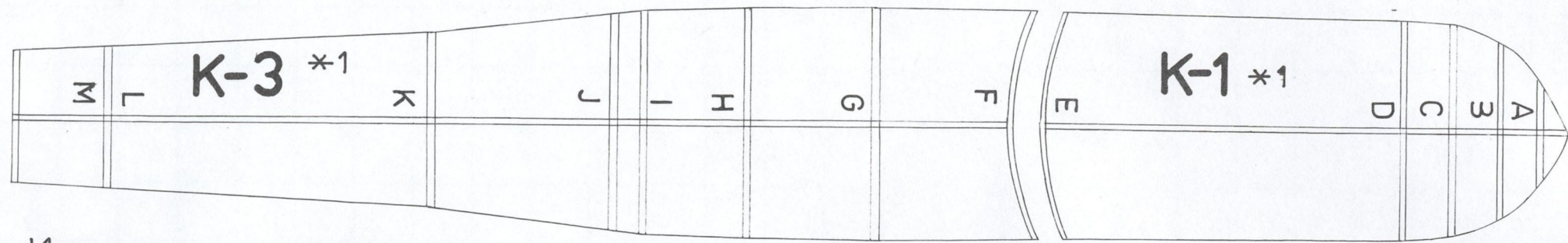
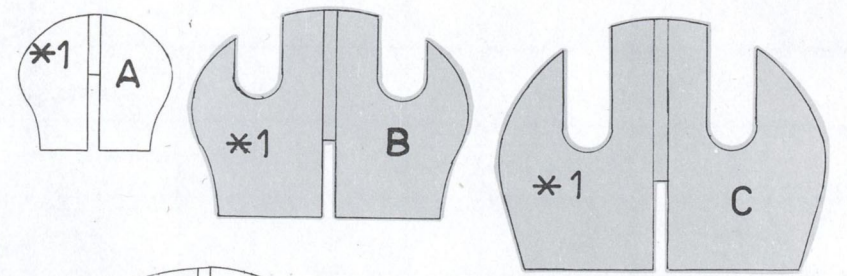
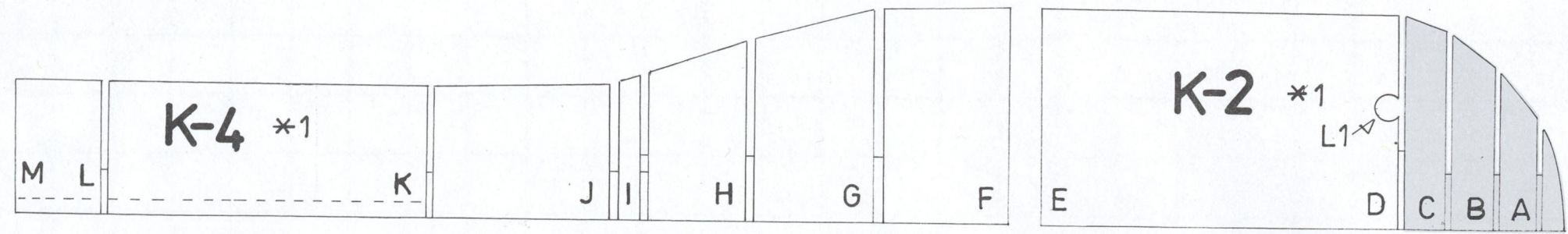

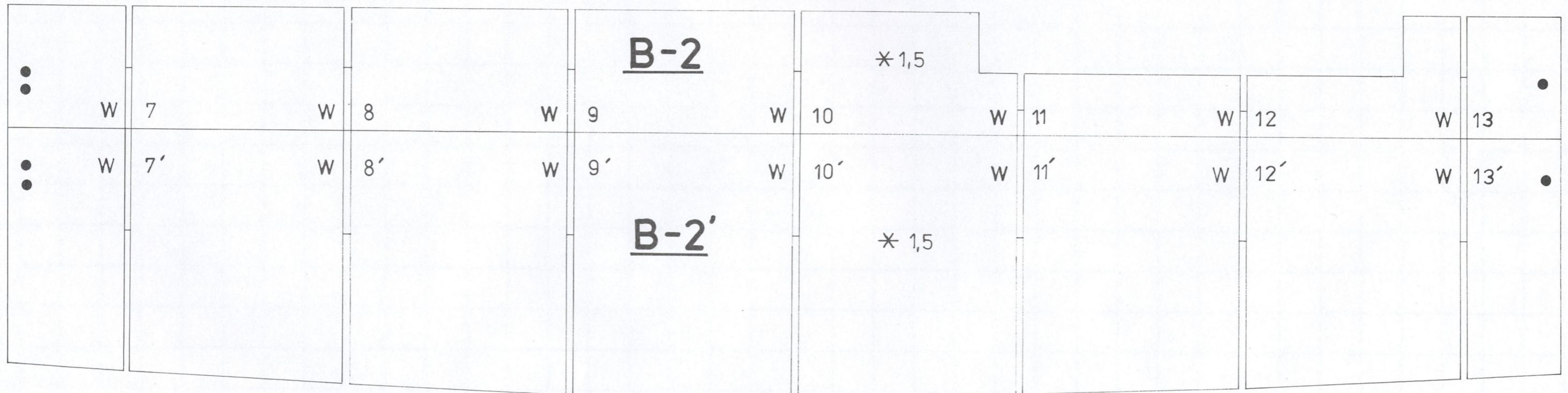
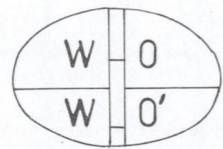
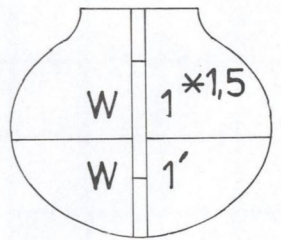
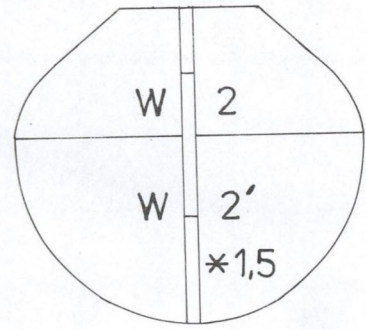
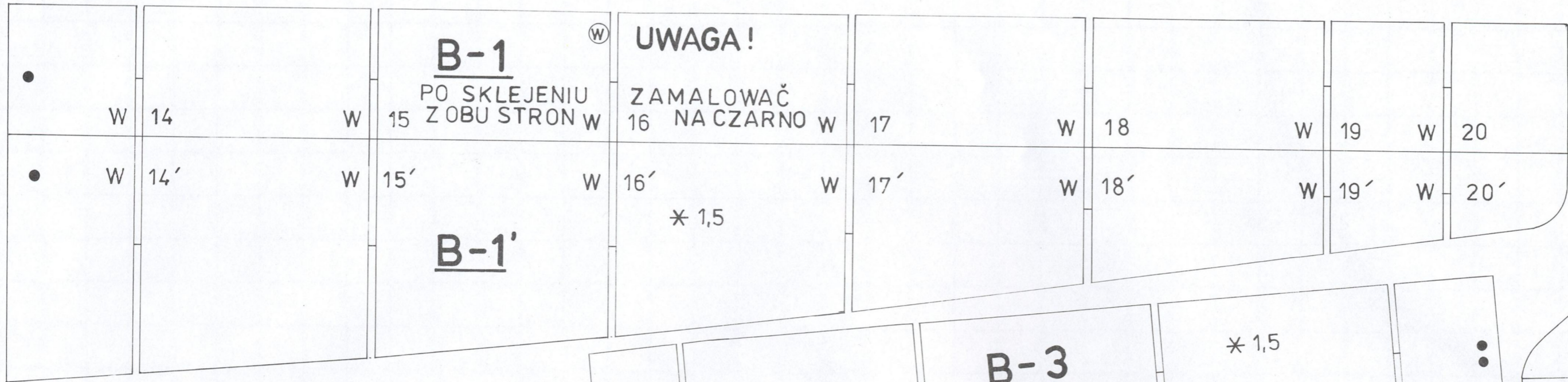

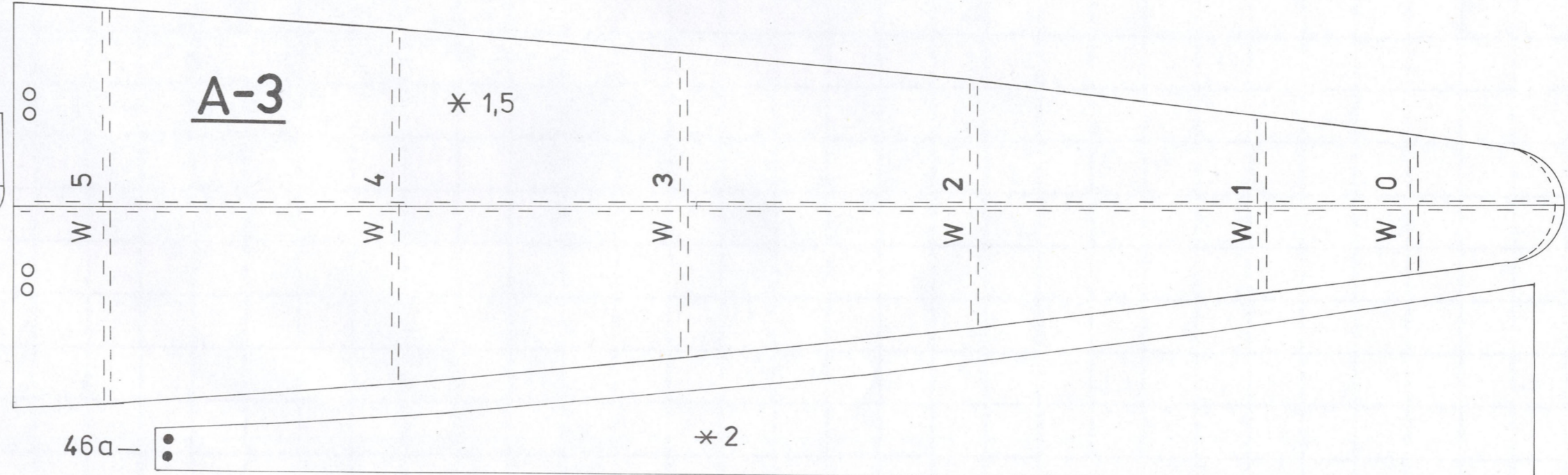
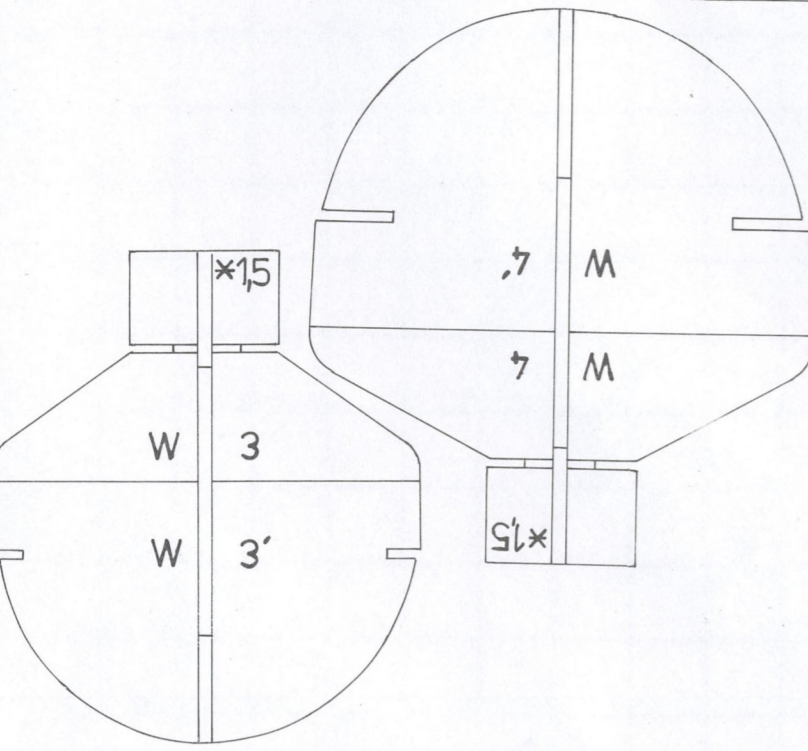
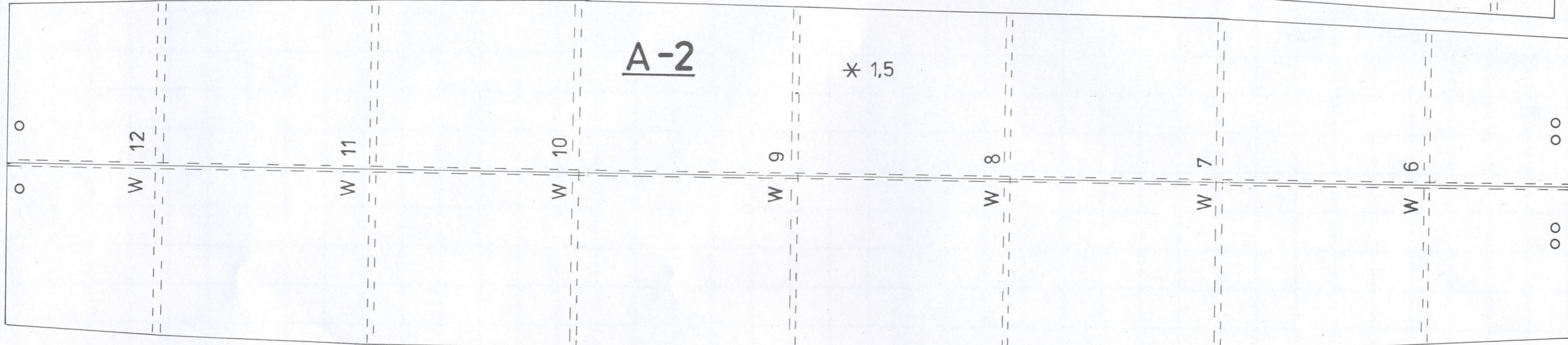
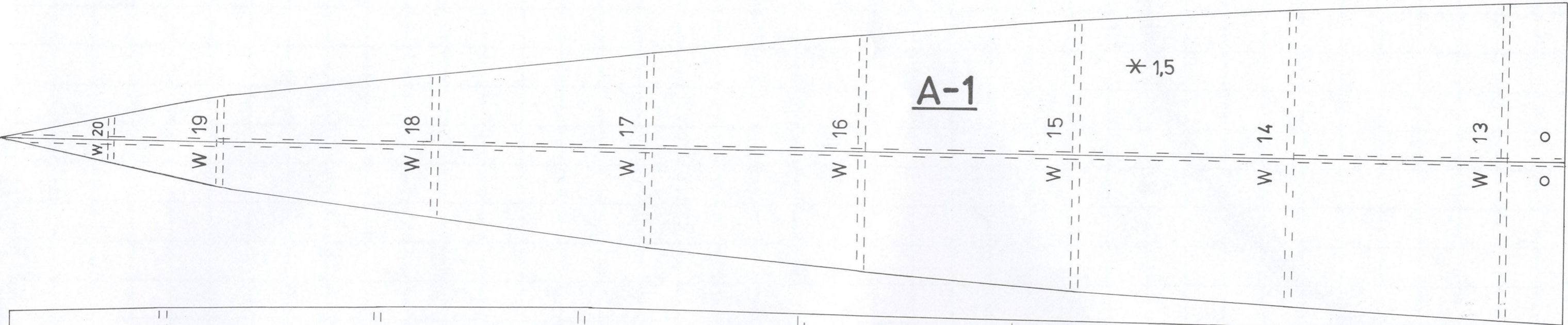

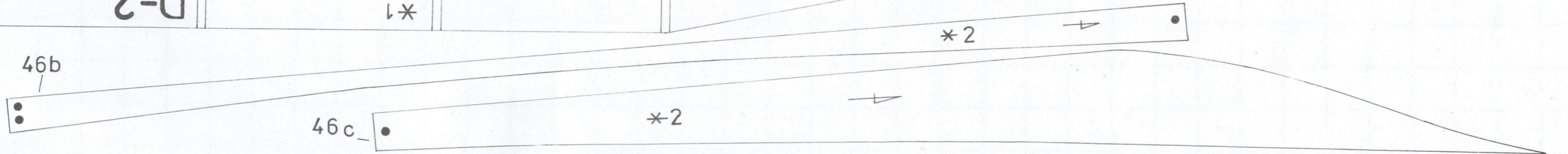
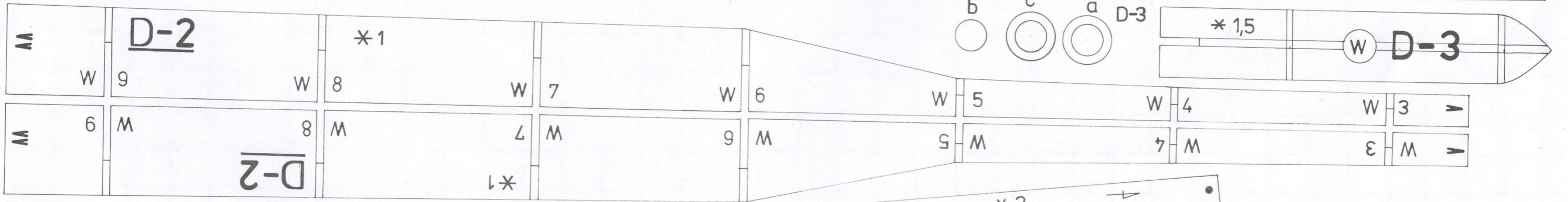
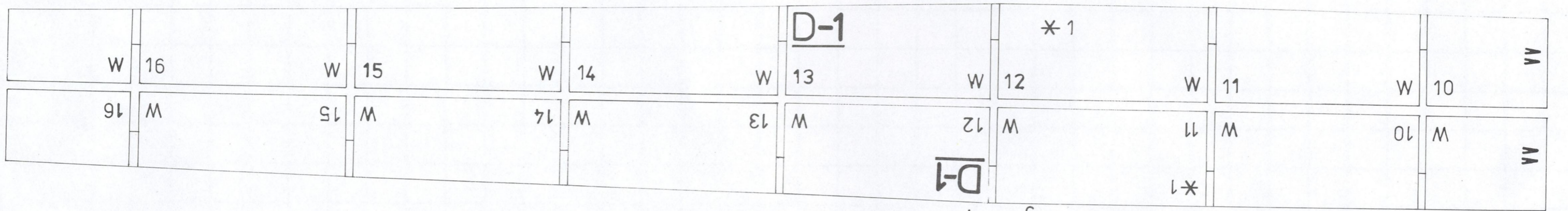
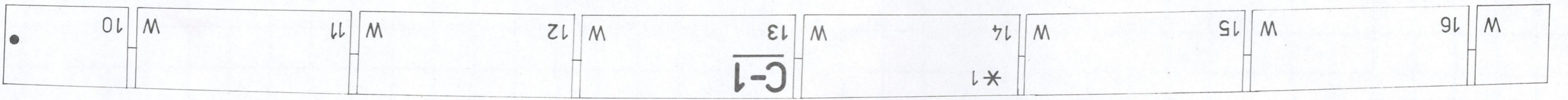
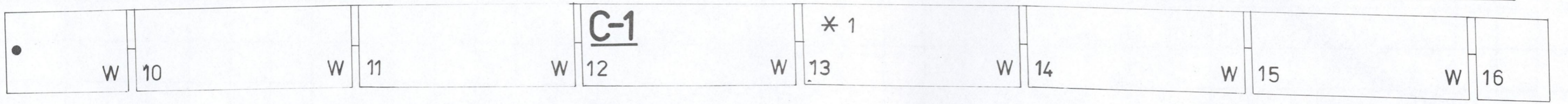
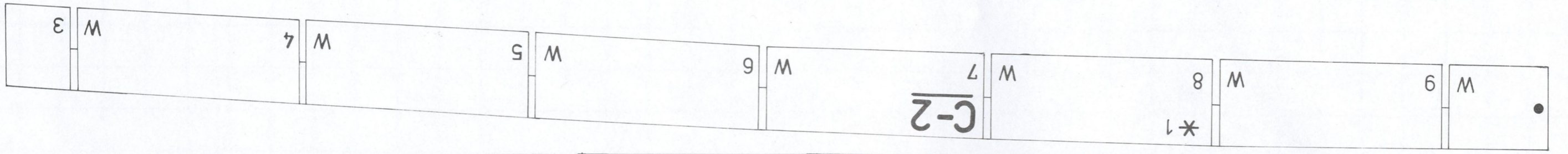
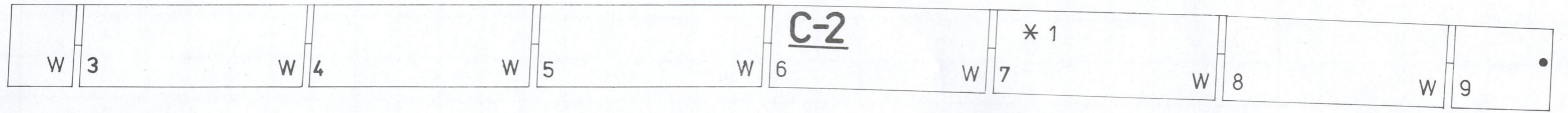

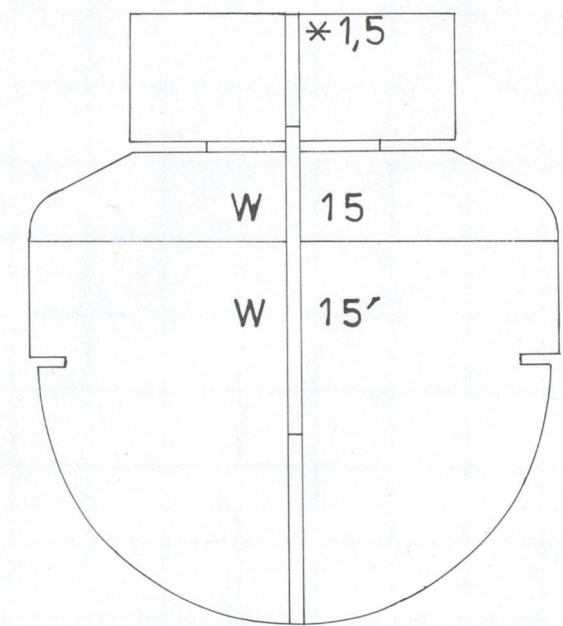
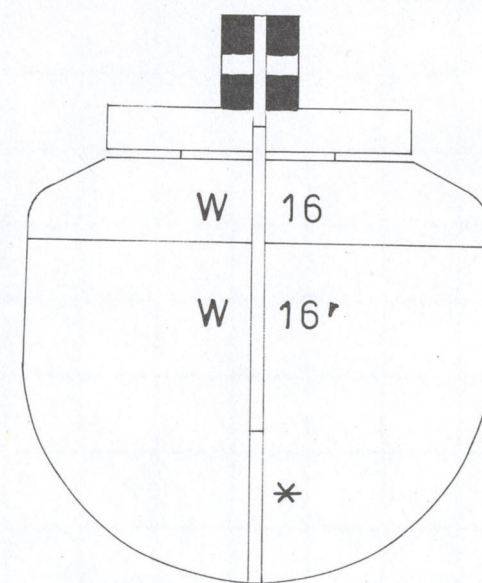
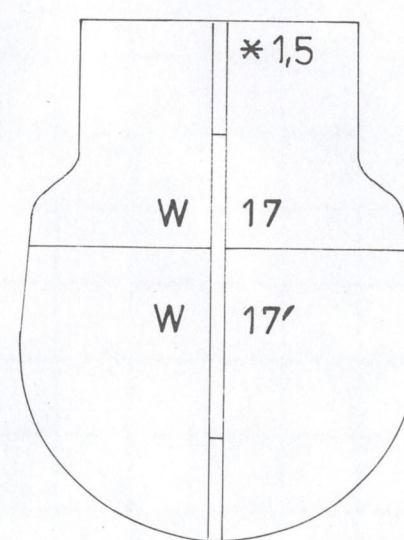
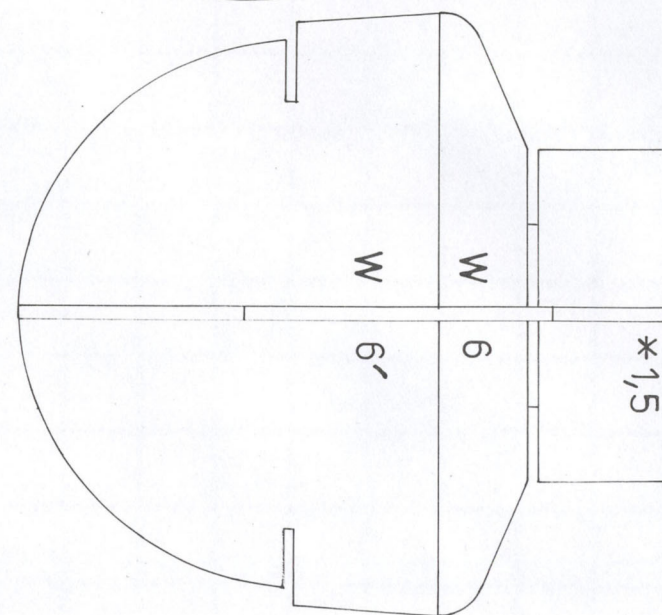
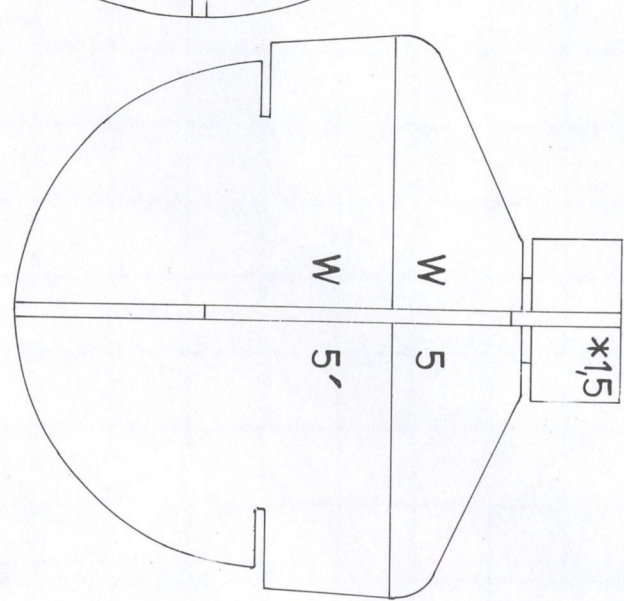
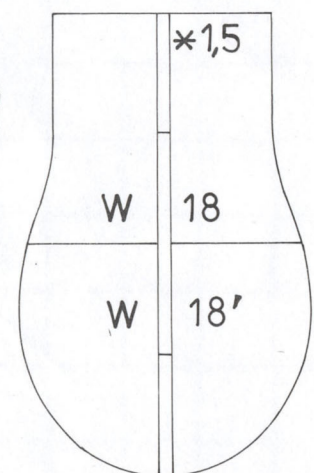
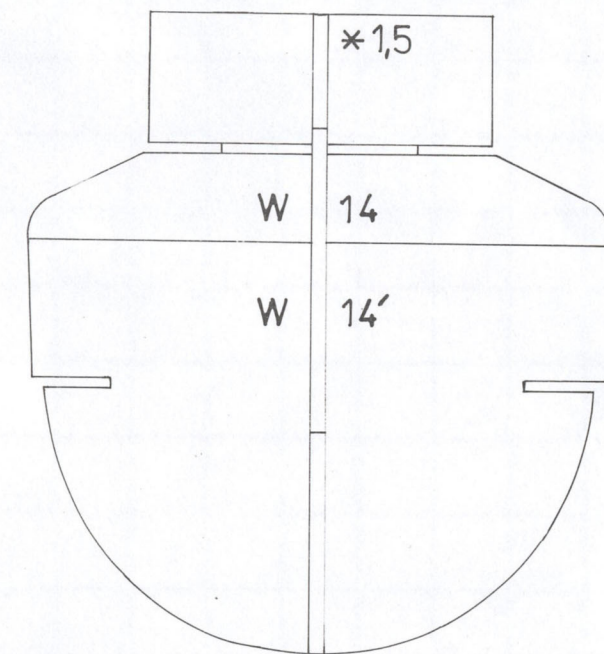
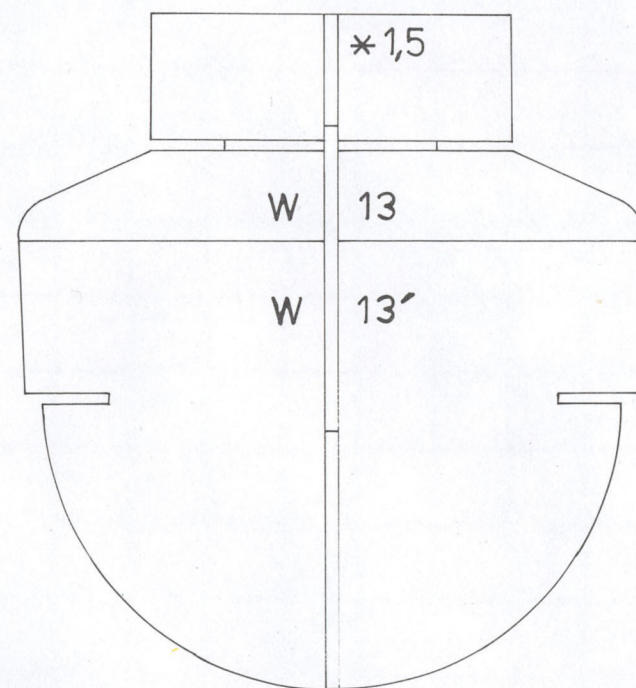
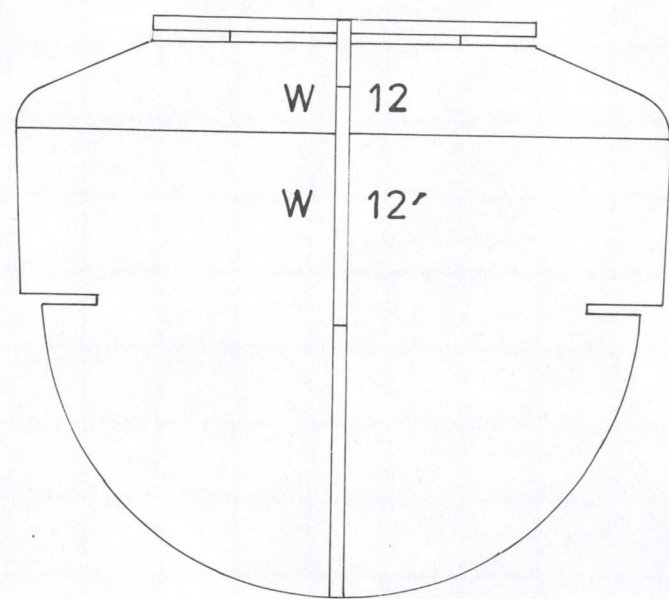
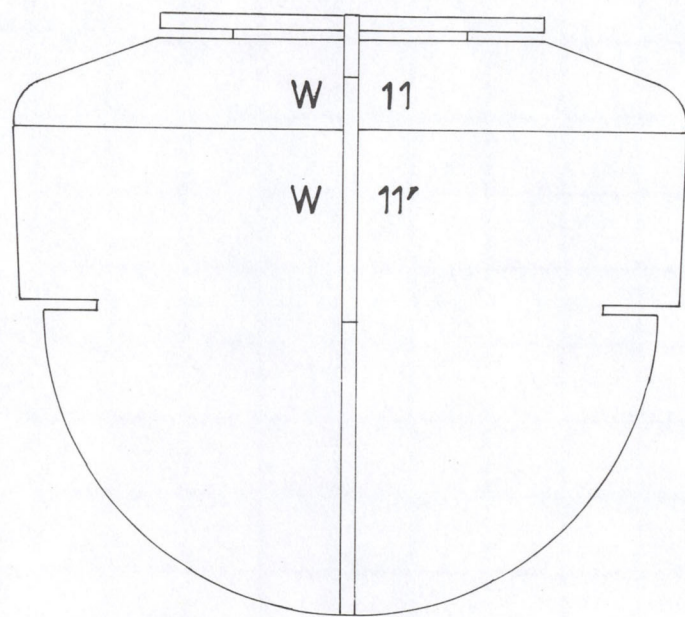
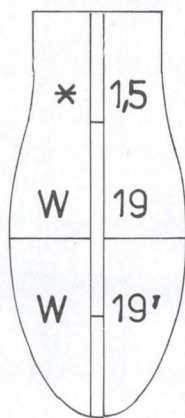
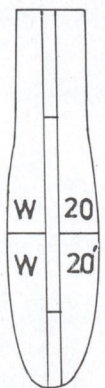
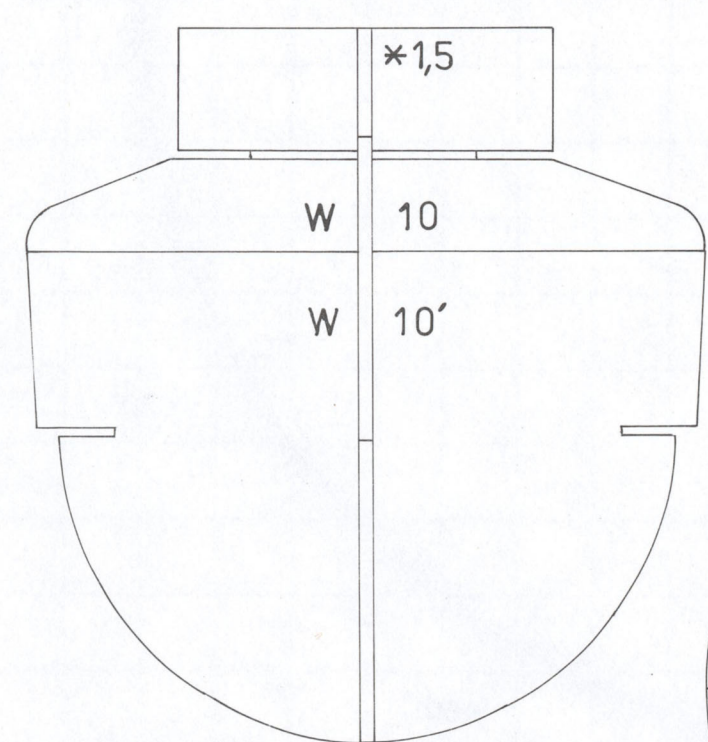
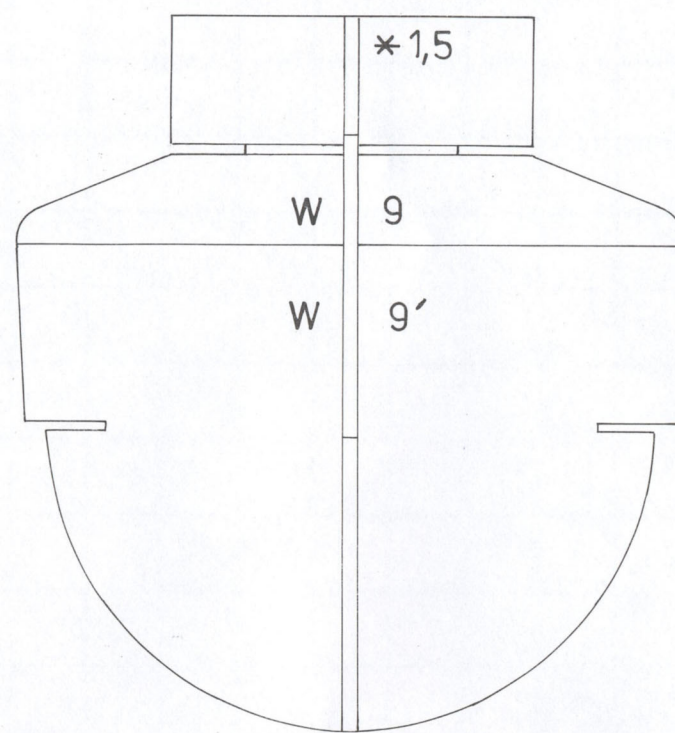
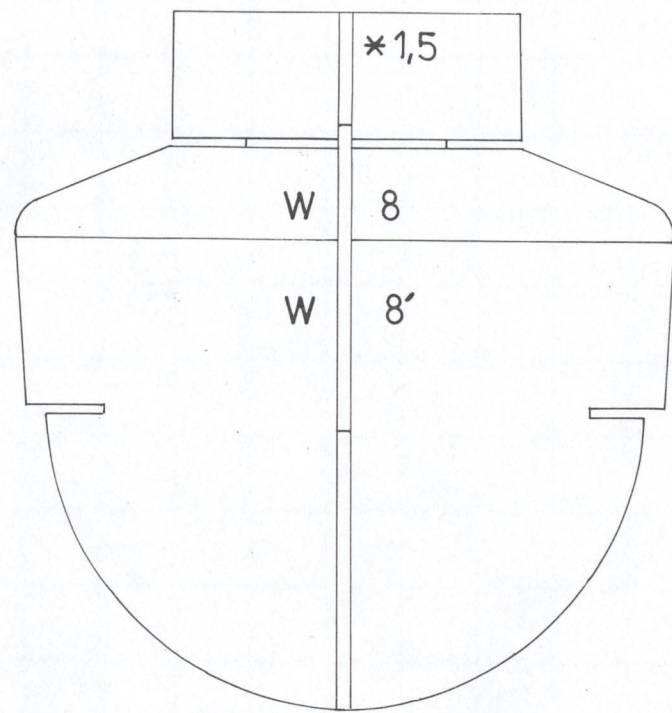
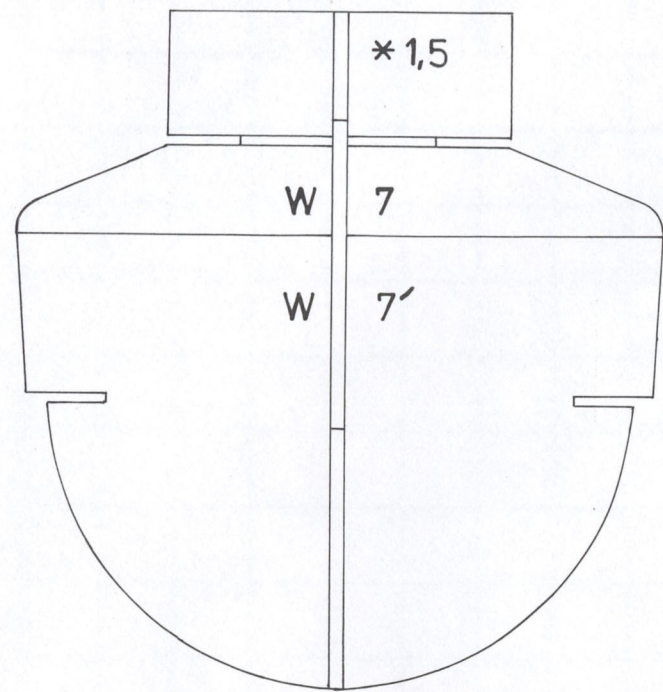



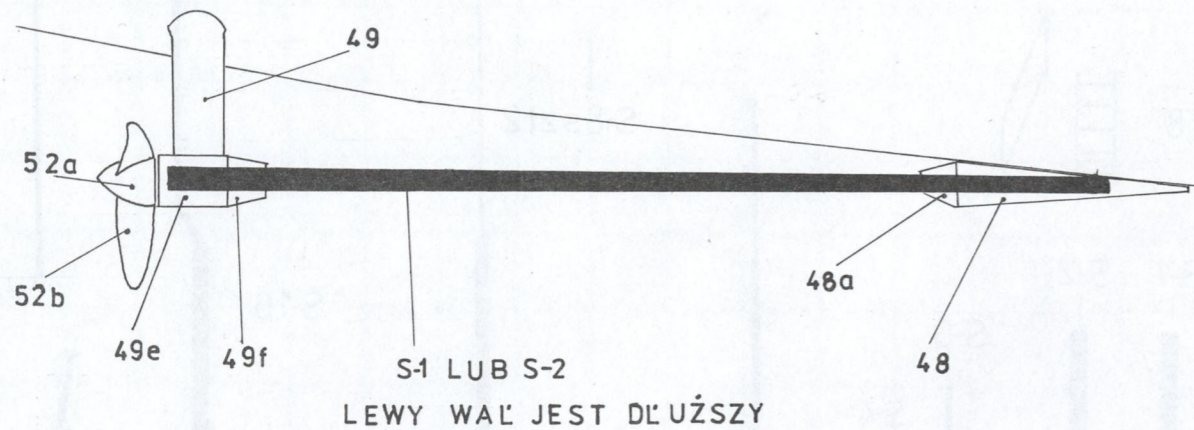

LEWY WAŁ JEST DŁUŻSZY

