

PAPER CRAFT



● View of completed model

Cathédrale Notre-Dame de Paris

Standing on the Ile de la Cite on the river Seine in Paris, this splendid cathedral is the world's most famous 12th century gothic masterpiece.

This historical giant, constructed over a period of almost 200 years, from 1163 to 1345, witnessed the coronation of the Emperor Napoleon in 1804. The cathedral was listed as a World Heritage Site in 1991.

The front facade of the cathedral features three portals, showing scenes of the Last Judgement, the Virgin Mary and Saint Anne, her mother, in the tympana. The cathedral's magnificent stained glass rose window is breathtaking. Also, the 69m tall bell tower affords a spectacular view of the whole of Paris.

* This model was designed for Papercraft and may differ from the original in some respects.

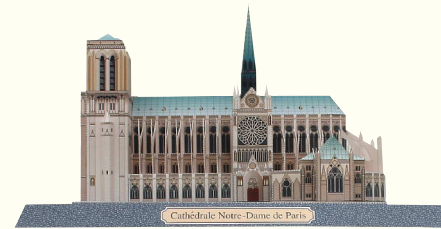

● South face



● East face

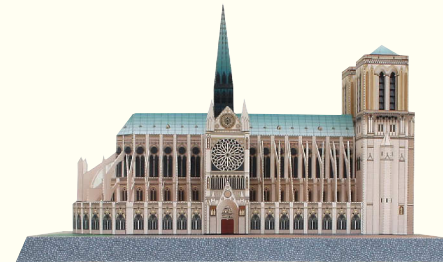

● North face

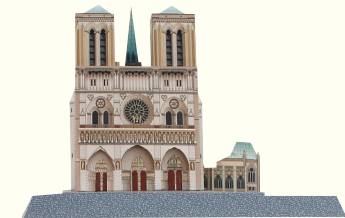

● West face

■ Parts list [Pattern] : Nine A4 sheets (No. 1 to No. 9)

■ No. of Parts: 60

■ [Assembly Instructions] : Five A4 sheets (No. 1 to No. 5)

* Build the model by carefully reading the [Assembly Instructions], in the parts sheet page order.

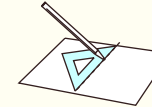

★ Hint: Trace along the folds with a ruler and a used pen (no ink) to get a sharper, easier fold.

Assembly Instructions

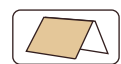

----- Mountain fold (dotted line)

● Make a mountain fold.

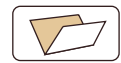

- - - - - Valley fold (dashed and dotted line)

● Make a valley fold.



———— Scissors line (solid line)

● Cut along the line.



———— Cut in line (solid line)

● Cut along the line.

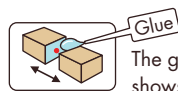

● Glue spot (Red dot)

Glue parts with the same number together.

● Glue spot (Green dot)

Glue within the same part.

● Glue spot (Blue dot)

Glue to the rear of the other part.

Tools and materials



● Scissors, set square, glue (We recommend stick glue), pencil, used ballpoint pen, tweezers, (useful for handling small parts)

Assembly tip



● Before gluing, crease the paper along mountain fold and valley fold lines and make sure rounded sections are nice and stiff.

Caution



● Glue, scissors and other tools may be dangerous to young children so be sure to keep them out of the reach of young children.

■ Before starting.

- There is a sheet number (No. 1 to No. 9) printed at the bottom center of each Pattern page. Assemble the model in the order of the page numbers.
(*Assembly parts are on sheets No. 2 to No. 9.)
- There are a total of 60 parts and each sheet carries a parts symbol. Also, the 'glue spot' on each part bears the number of the part to which it should be glued. Before cutting out any part, it is a good idea to write the parts symbol on the back.
(*This is to avoid losing track of which part is which, once they have been cut out.)
- Where there are multiple joints within a single part, or 'glue spots' where the part is to be glued to another, there are colors ●●● and numbers to give detailed instructions as to the correct positions.

Sheet No.2

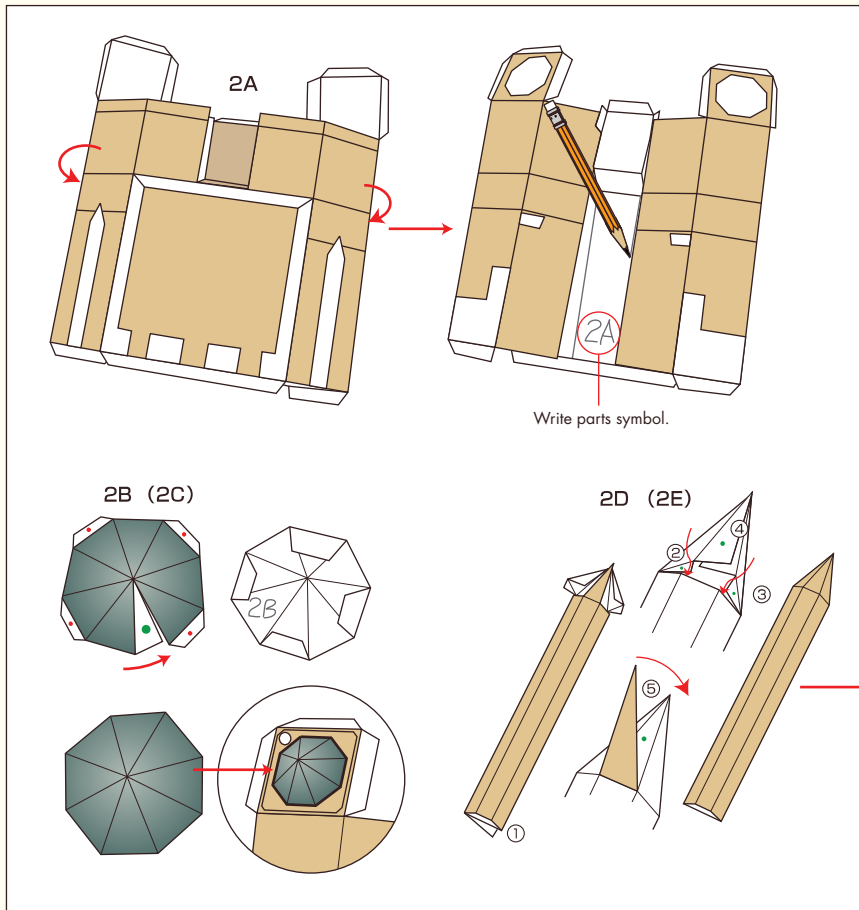

Sheet No.3

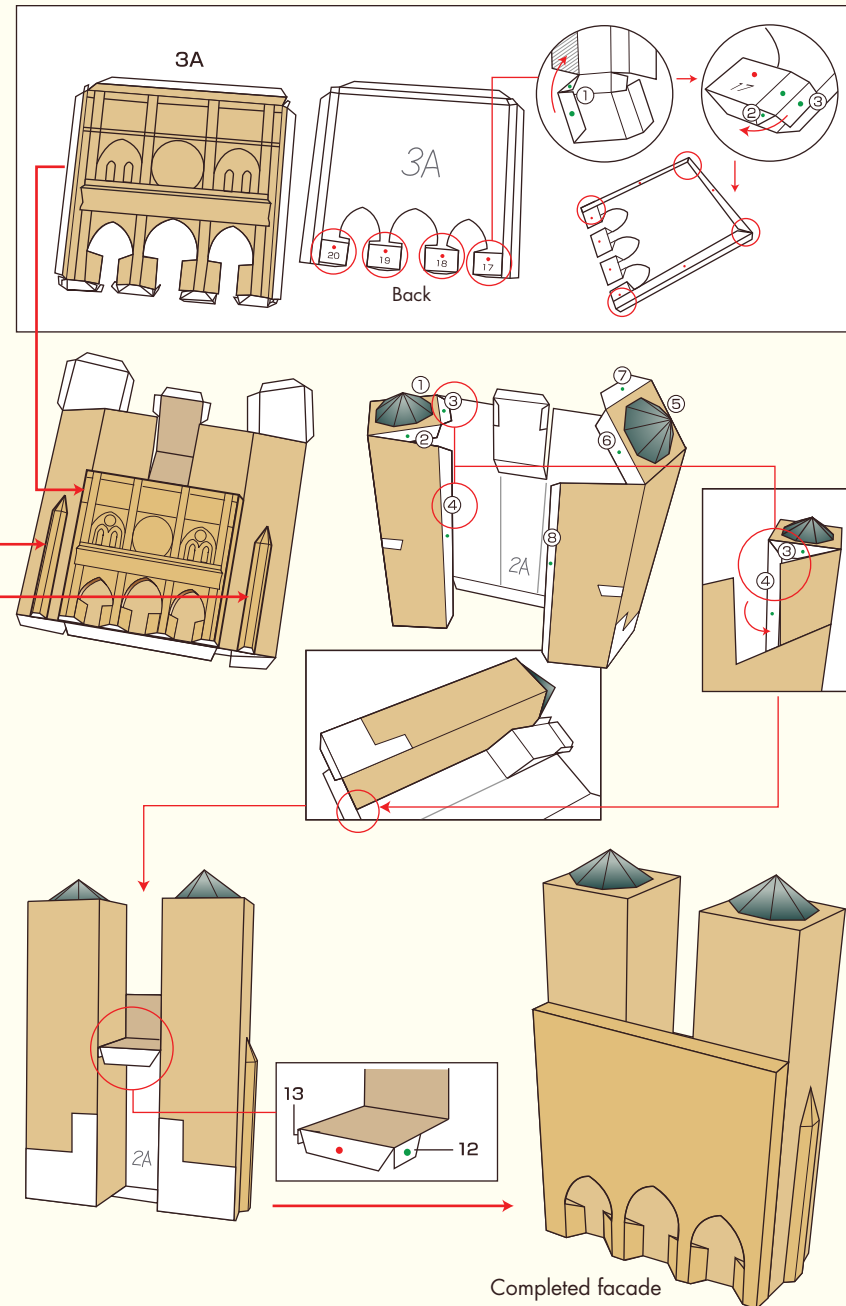

Sheet No.3

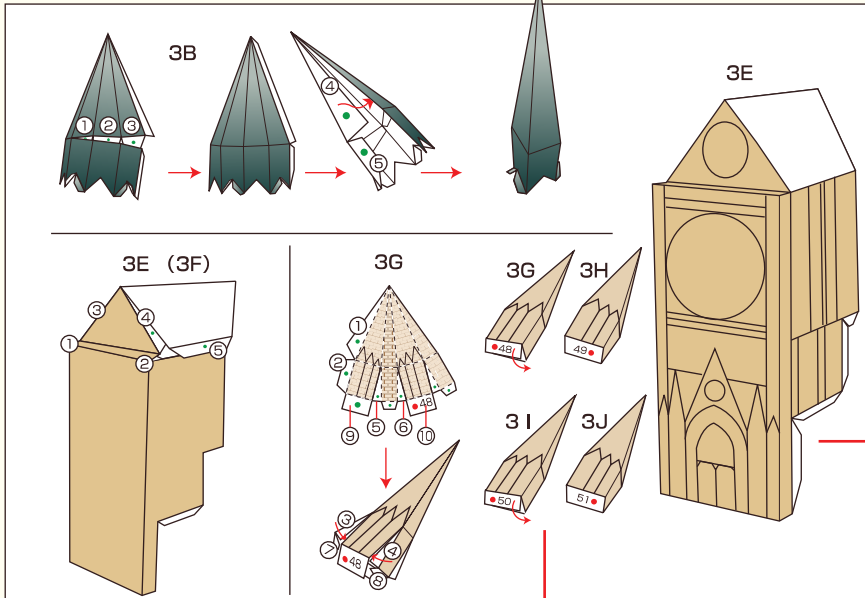

Sheet No.4

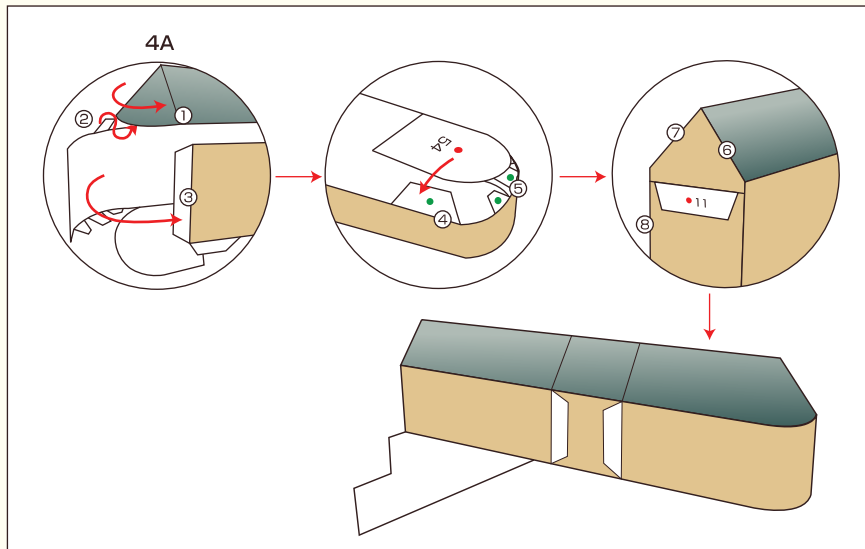

Sheet No.5

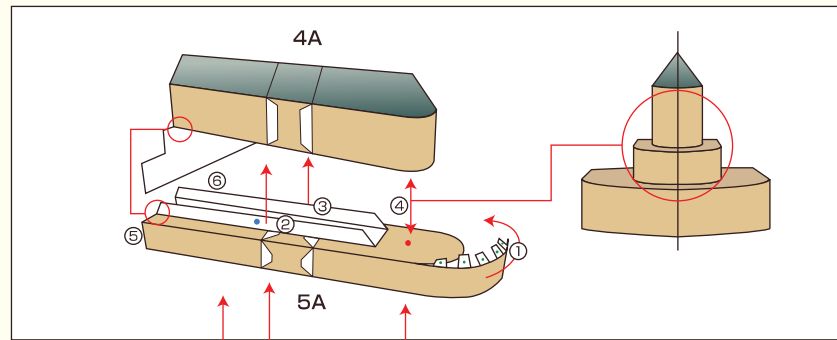

Sheet No.6

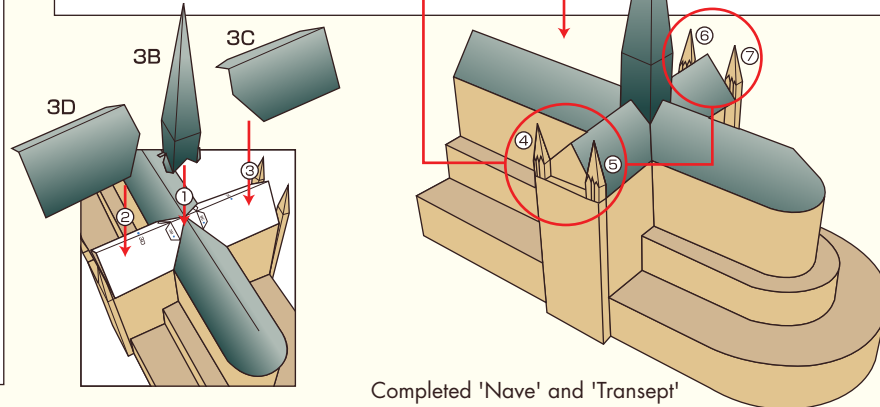
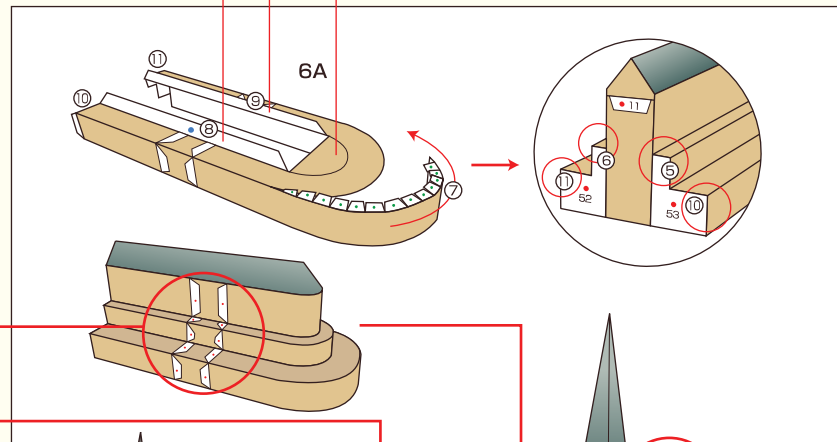

Completed 'Nave' and 'Transept'

Sheet No.4·5·6·7

- No.4 : 4B 4C 4D 4E 4F 4G 4H 4I
- No.5 : 5B 5C 5D 5E 5F 5G 5H 5I 5K 5L 5M 5N 5O
- No.6 : 6B 6C 6D 6E 6F 6G
- No.7 : 7E 7F 7G 7H

* 32 in total.

* Write parts symbol.

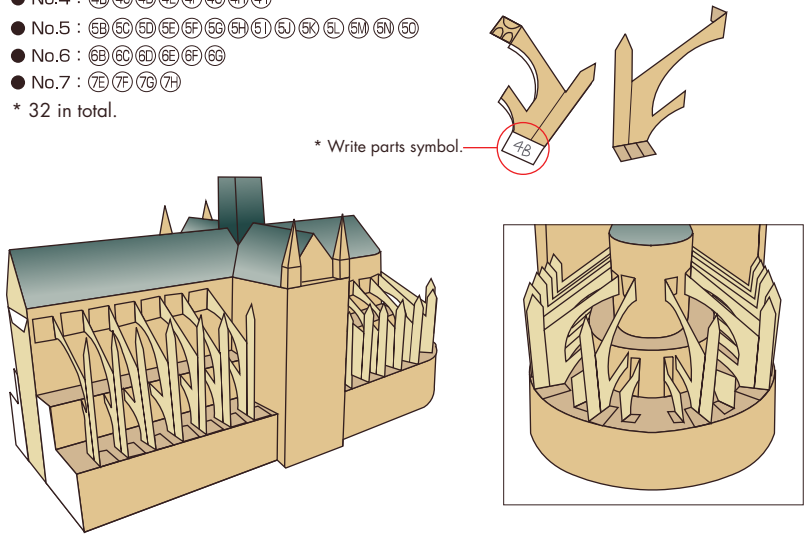

Sheet No.7

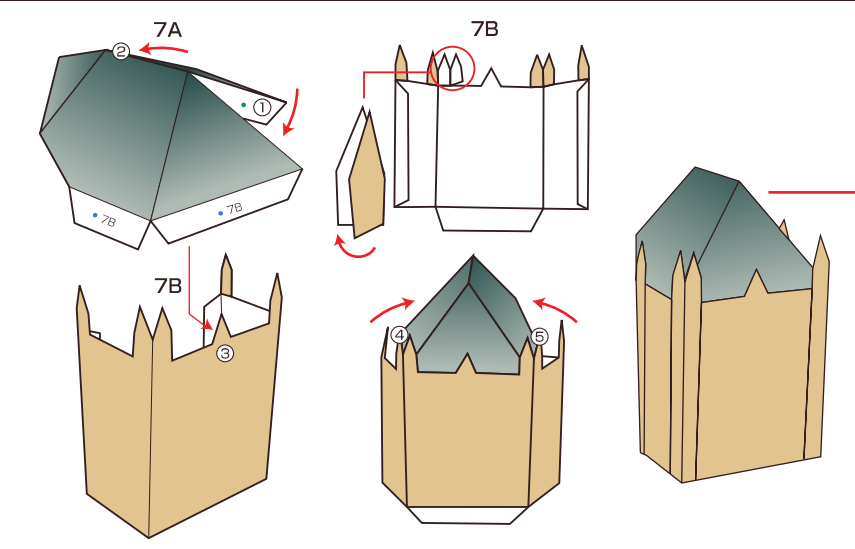

Sheet No.4

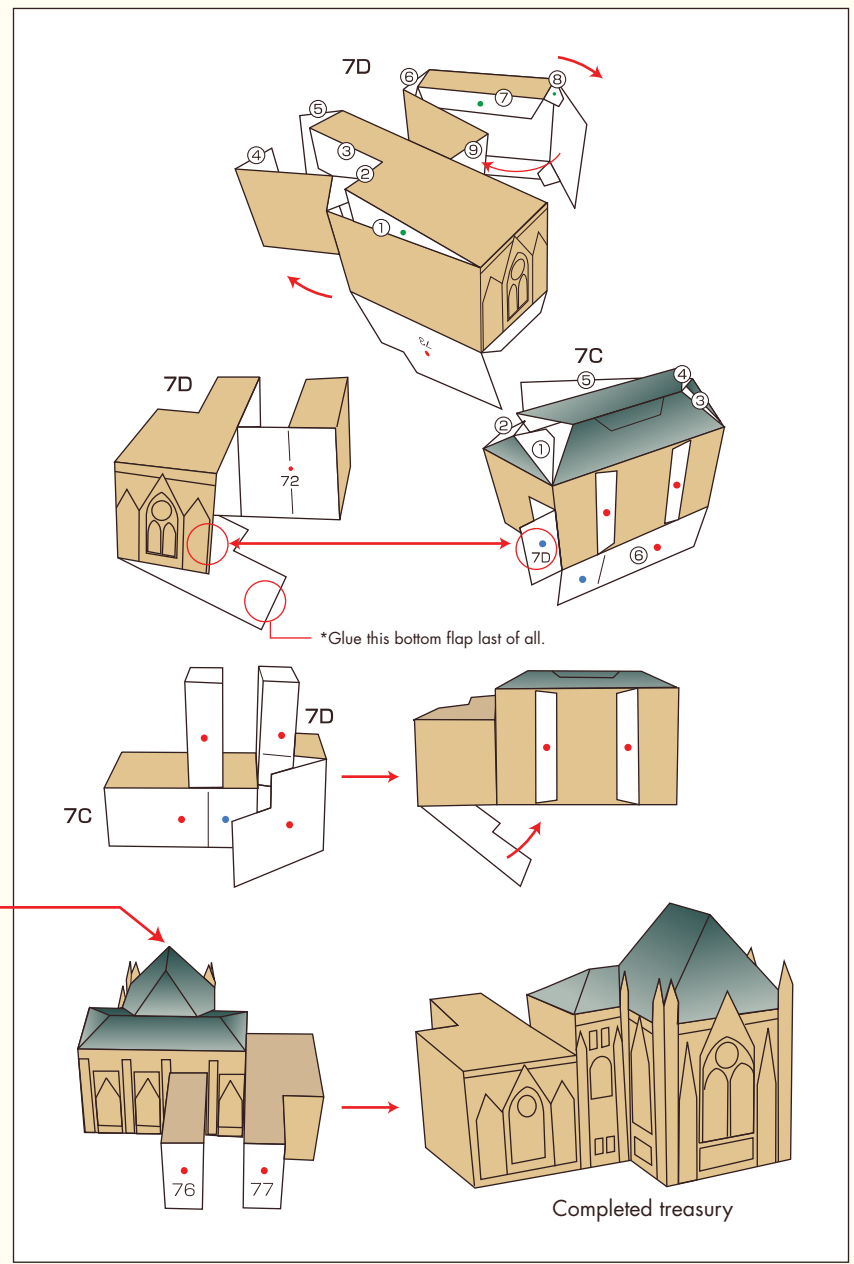

* Glue this bottom flap last of all.

Completed treasury

Sheet No. 8

8A

Cut out 8A and mark a cross on the back, bisecting the centre with a vertical and a horizontal line.

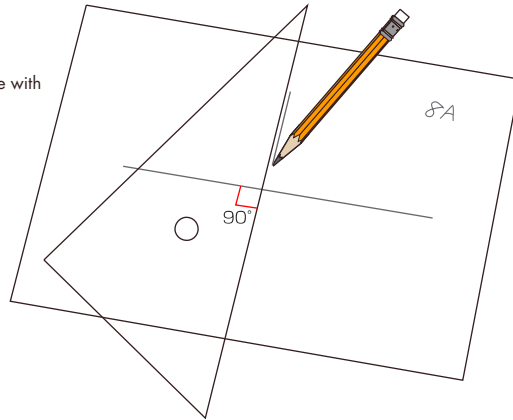

Sheet No. 9

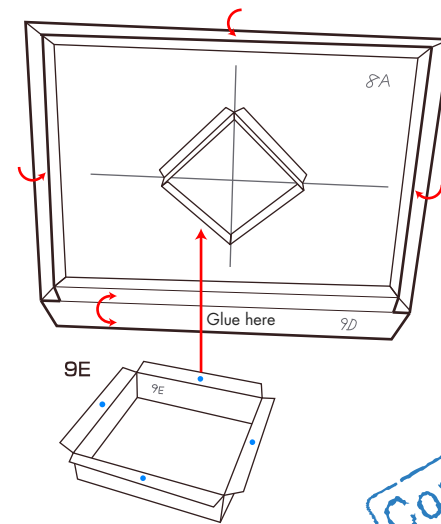
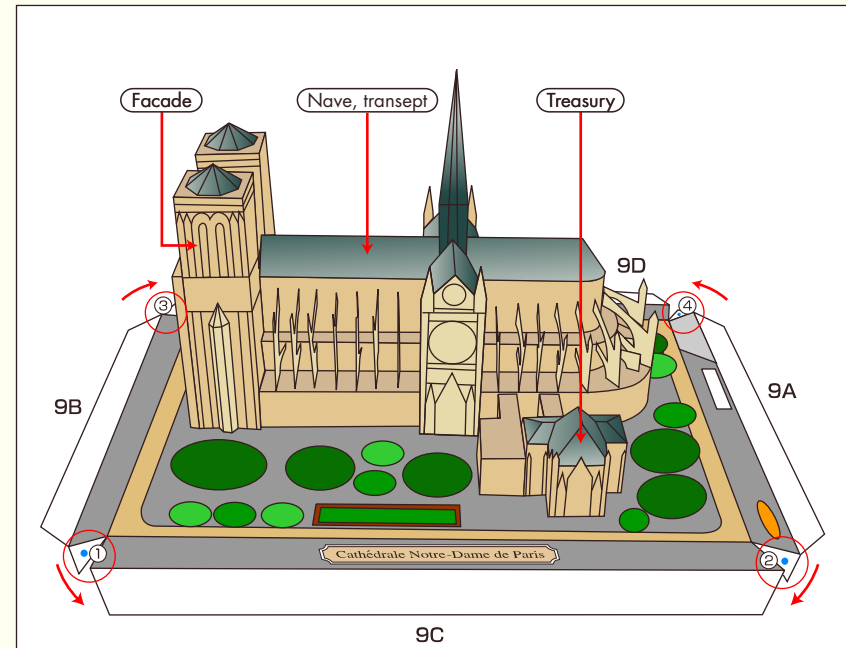
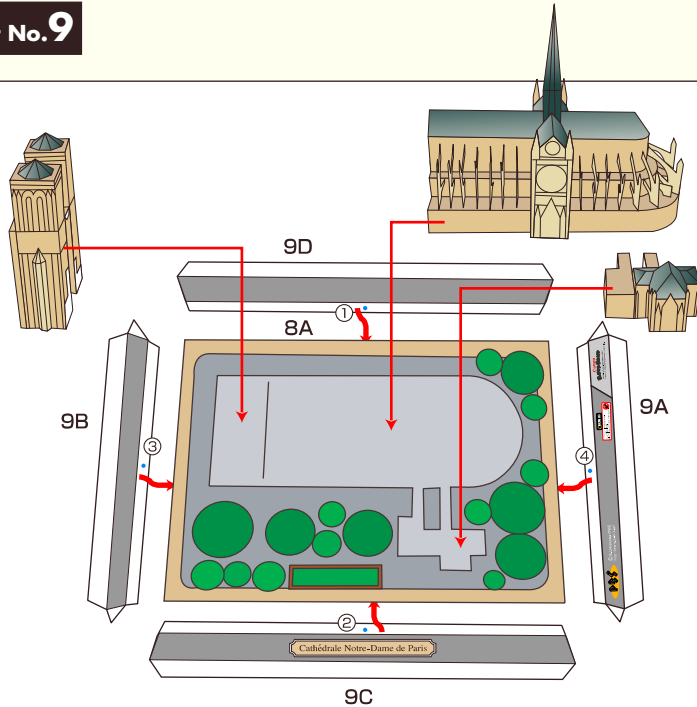

Completion