

Ecardmodels Paper Model

Electronic Download

Exclusive



ecardmodels.com



Rail Series #1

scale

HO

difficulty



ChS2 Built by **SKODA**

DC Electric Locomotive

Russia-Ukraine

www.ecardmodels.com

© 2012 ecardmodels.com All rights reserved

Legend:

* - glue 250 g\m2 paper 

- impregnated "superglue"

- cut. 

Recommendations for the assembly of the model: The assembly is divided into five sections:

1.FRAMEWORK - "FR"

2.BOOOTH - "B"

3.CORPS - "C"

4.EQUIPMENT ON THE ROOF- "ER"

5.WORKING PART - "WP"

The assembly recommended produced in the same order. During assembly, the following materials: Patterns (paper 250 g \ m) wires of different thickness (the thickness according to the templates), clear plastic from packages for simulation glasses (dimensions according to the templates).

All visible ends is recommended to paint a black marker. The upper rod, runners fixative rods, the axes of the lower rod current collectors, electrical conductors, insulator pins, rails, brake valves (T-11, T-12, T-15, T 10, T-17, T-18, T-19 T-16, T-29), which are made of wire, it is recommended to paint in red oil or acrylic paint.

Brake hoses, sand feeders, uncouple levers, sleeves heating pinches, controller (T-5, T-7, T-8, T-4, T-6, T-27, T-28), which are made of wire, it is recommended painted in black acrylic paint or lubricant.

Holders of antennas, connectors and beam trolley base, roofing bumpers (T-20, T-9, T-30), which are made of wire, recommended painted in gray color of the lubricant or acrylic paint. All rail (T-1, T-2, T-3), which are made of wire, it is recommended to paint white acrylic paint or lubricant.

Framework, booth

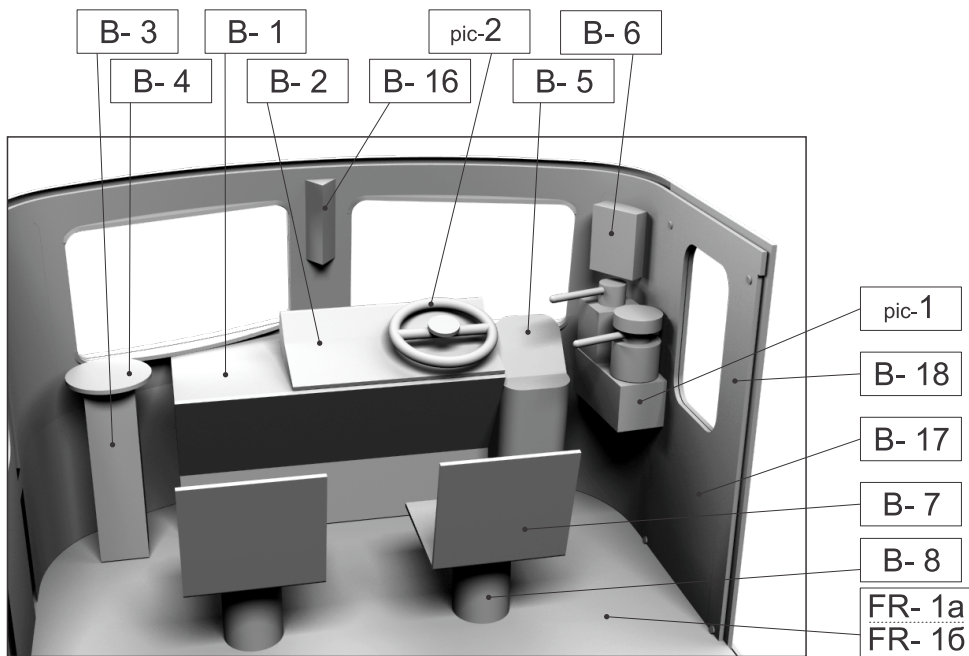
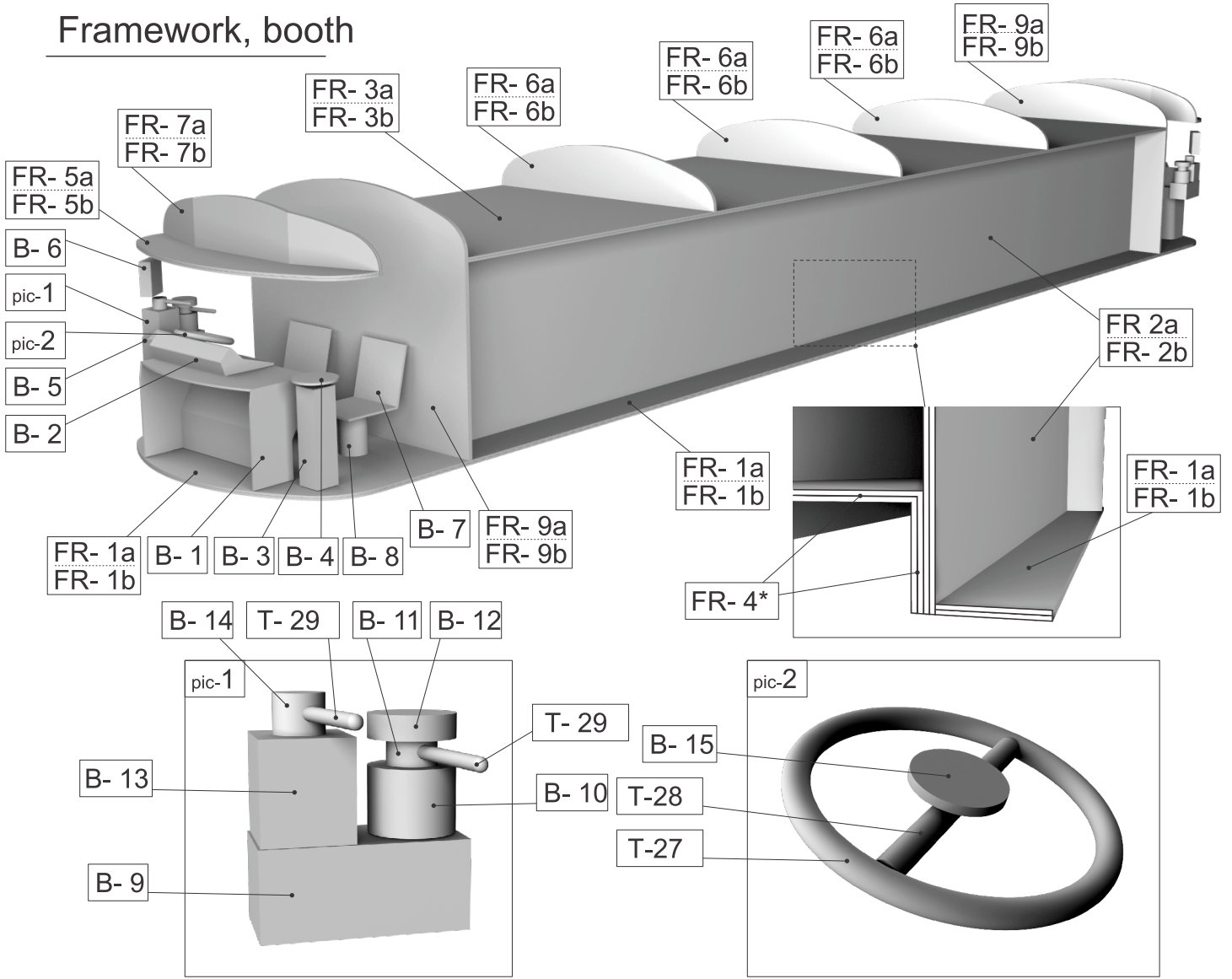

Corps

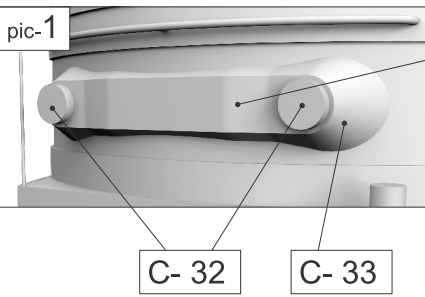
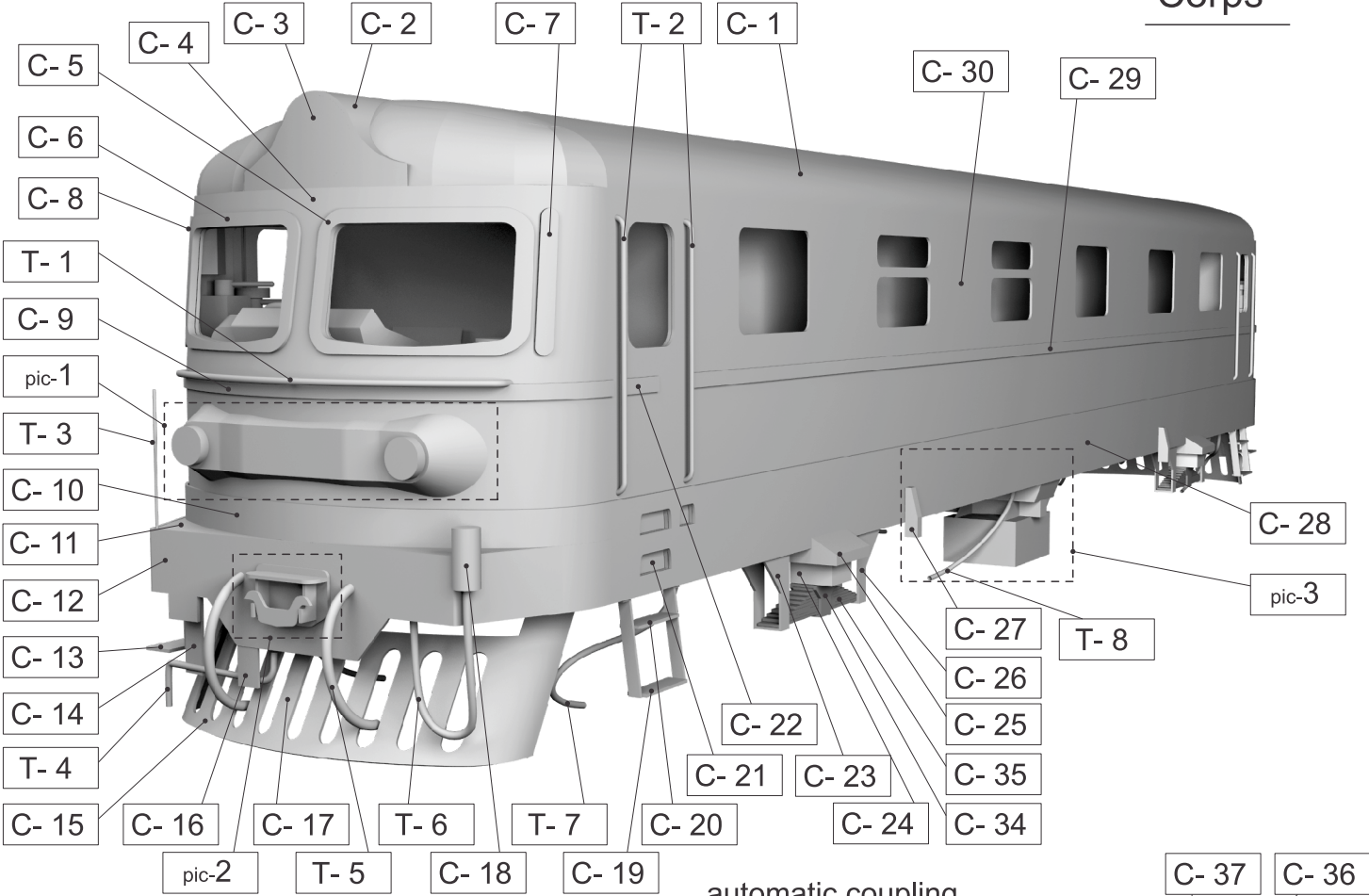

automatic coupling

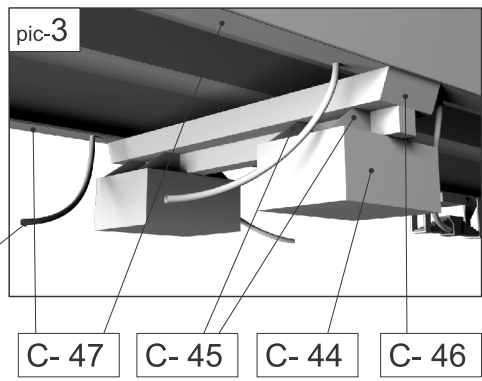
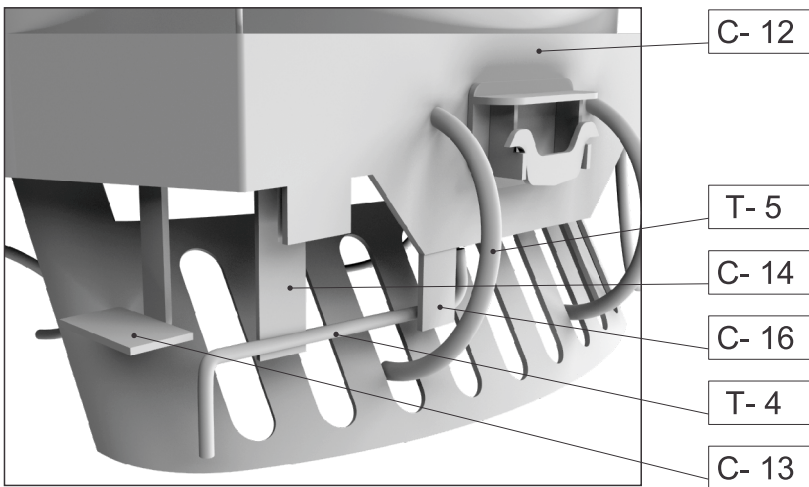
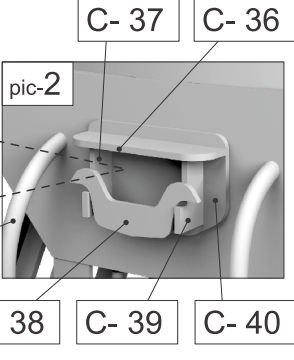
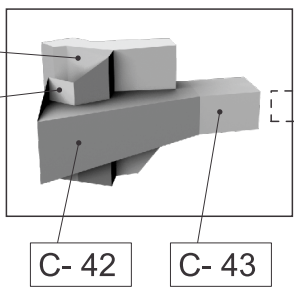

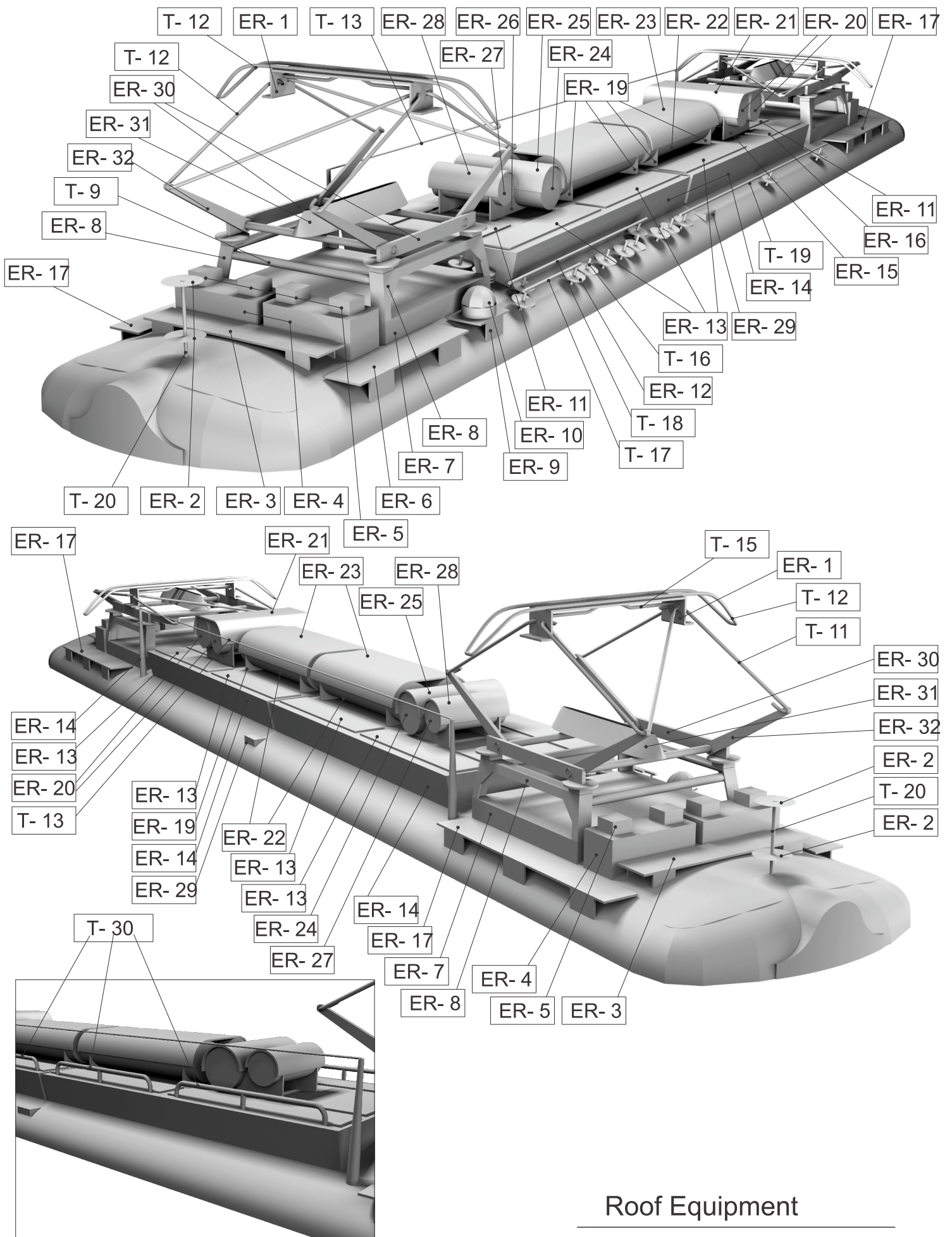

Roof Equipment

Pantograph

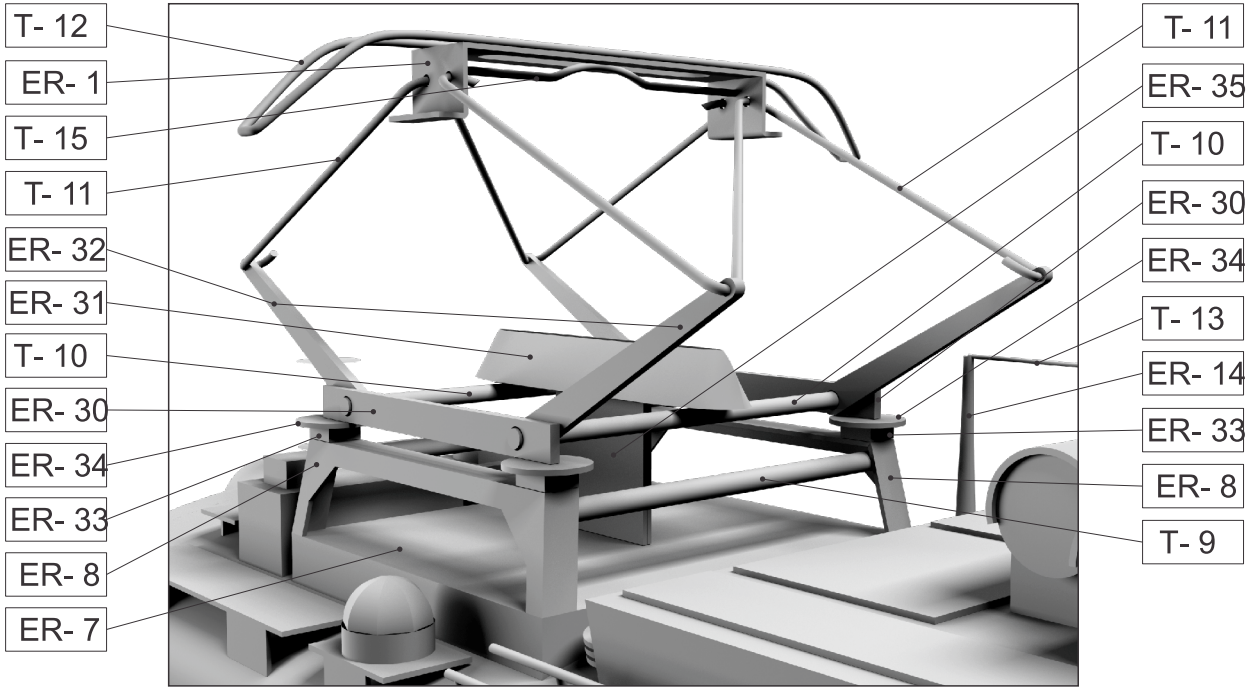

Working part 1

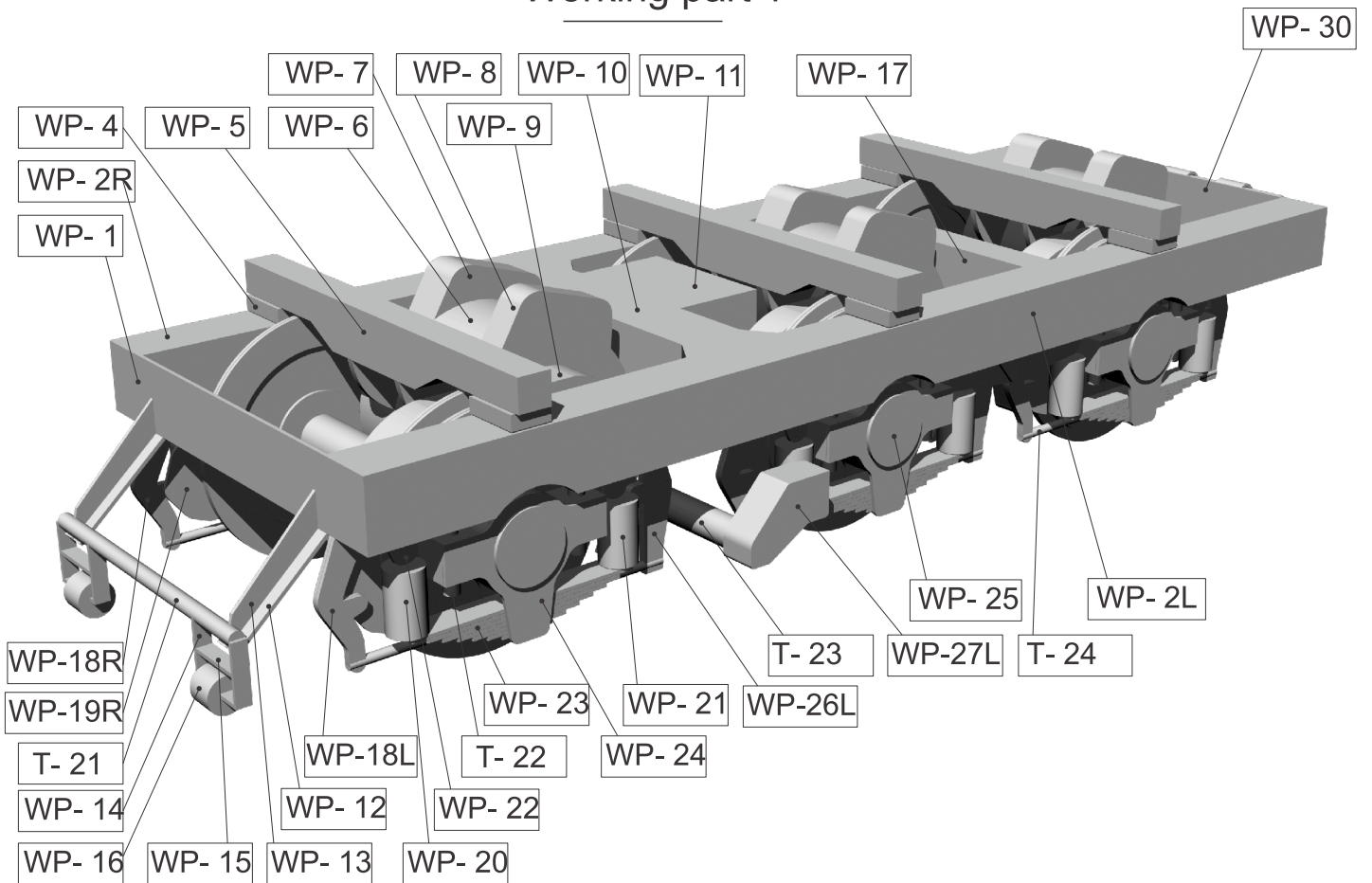

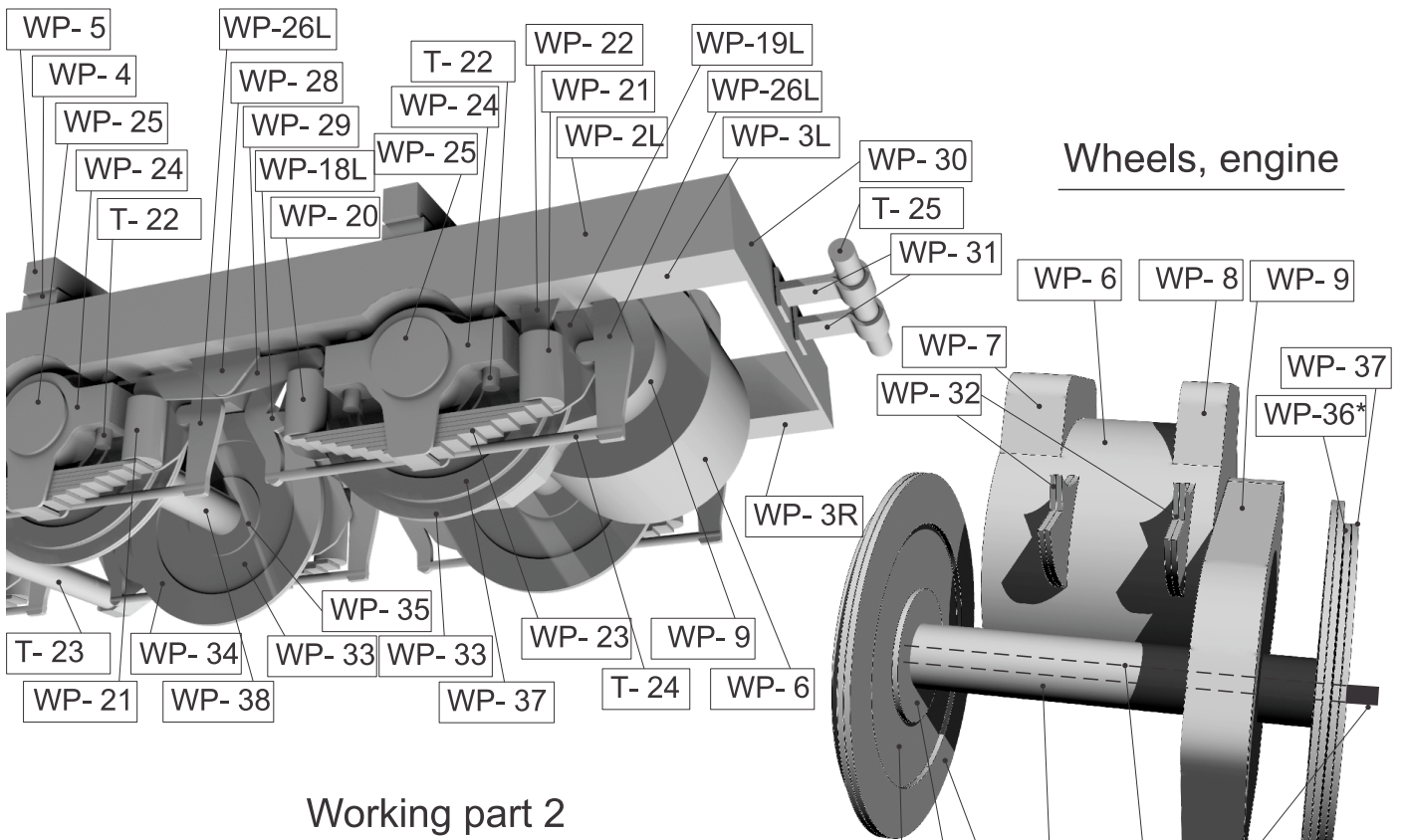

Working part 2

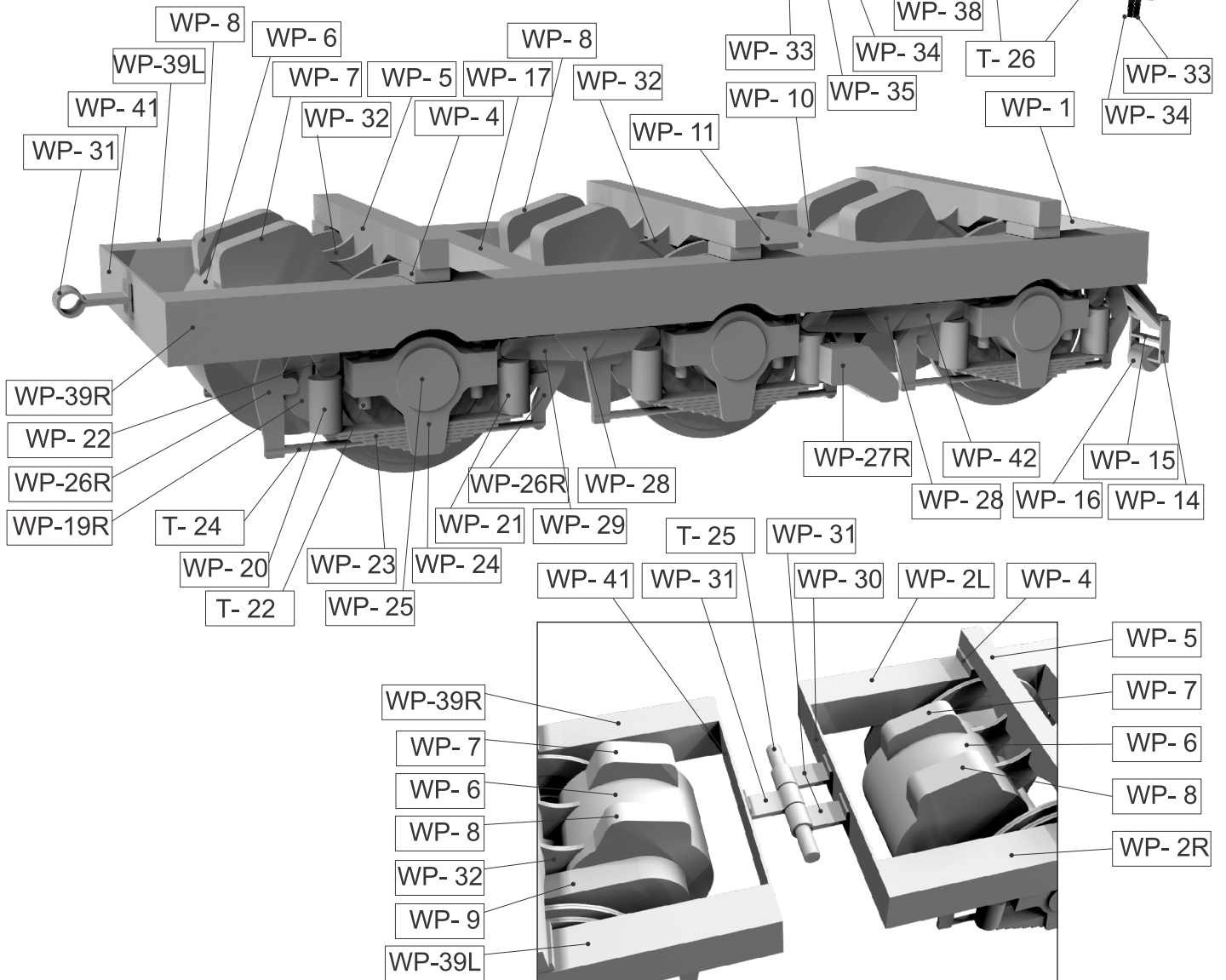



FR- 3b

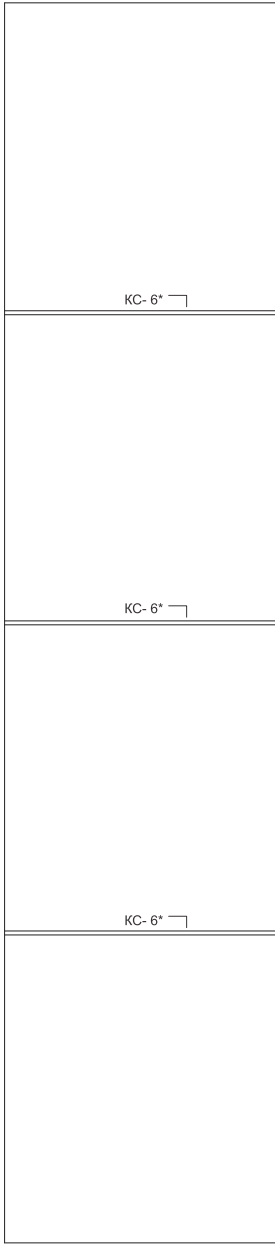

FR- 3a

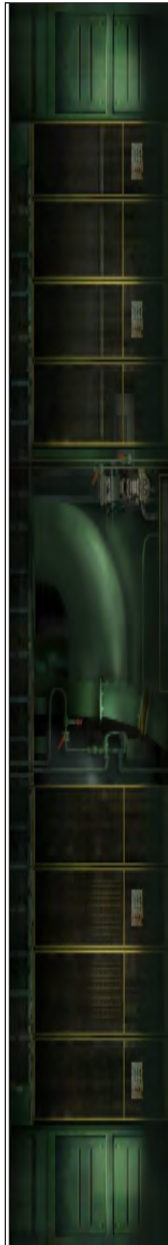

FR- 2b

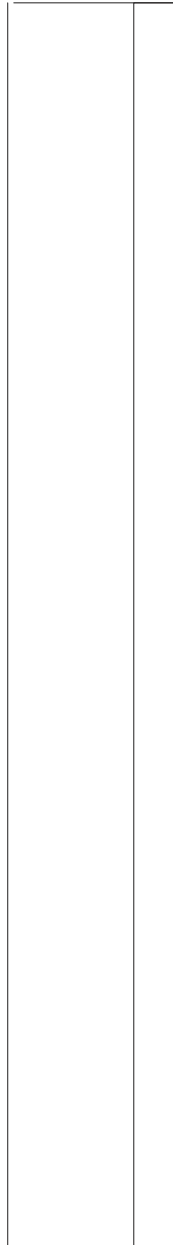

FR- 2a

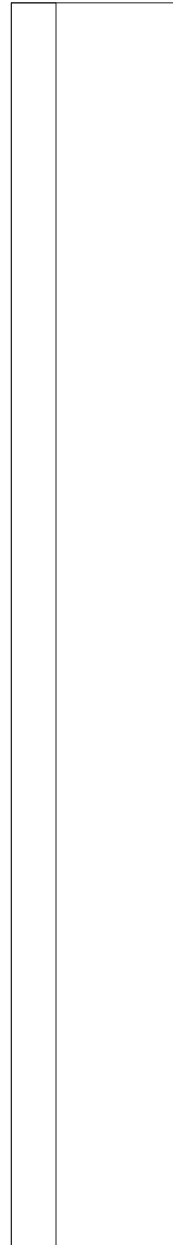

FR- 2a



FR- 2b

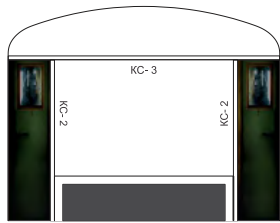

FR- 9b



FR- 9a

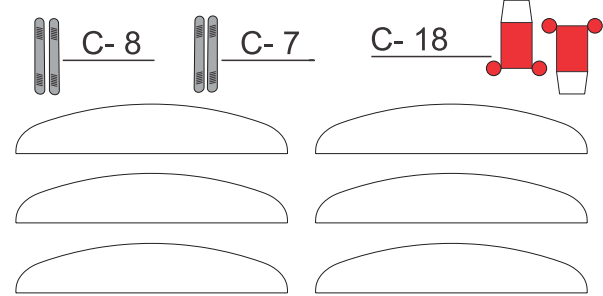
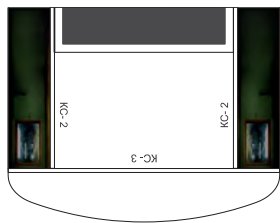

FR- 6a

FR- 6b

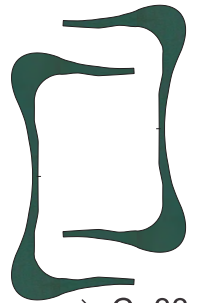

C- 33



FR- 5b

C- 14

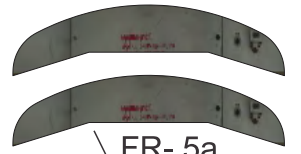

FR- 5a

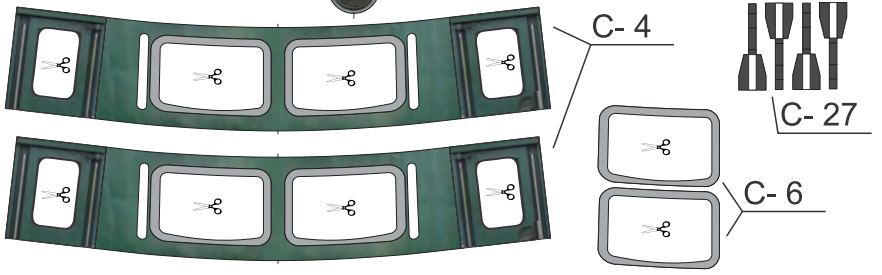
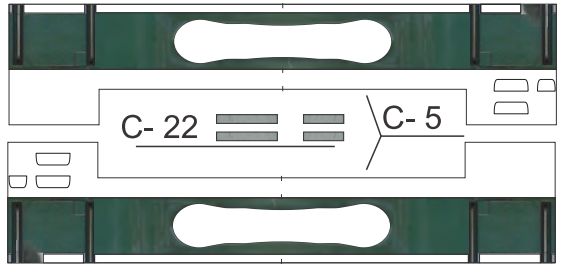
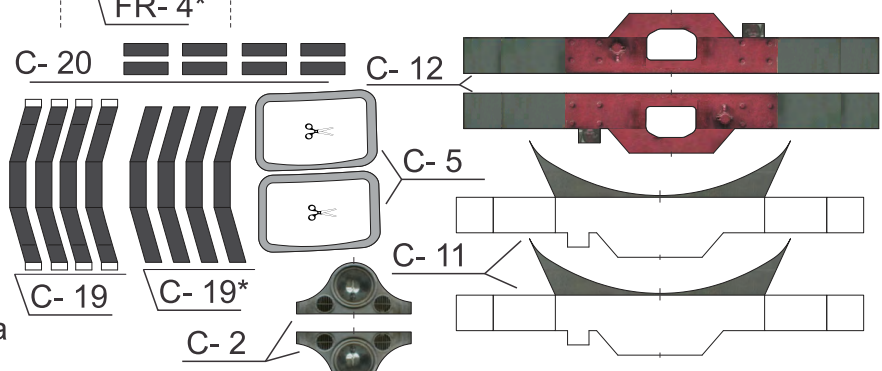
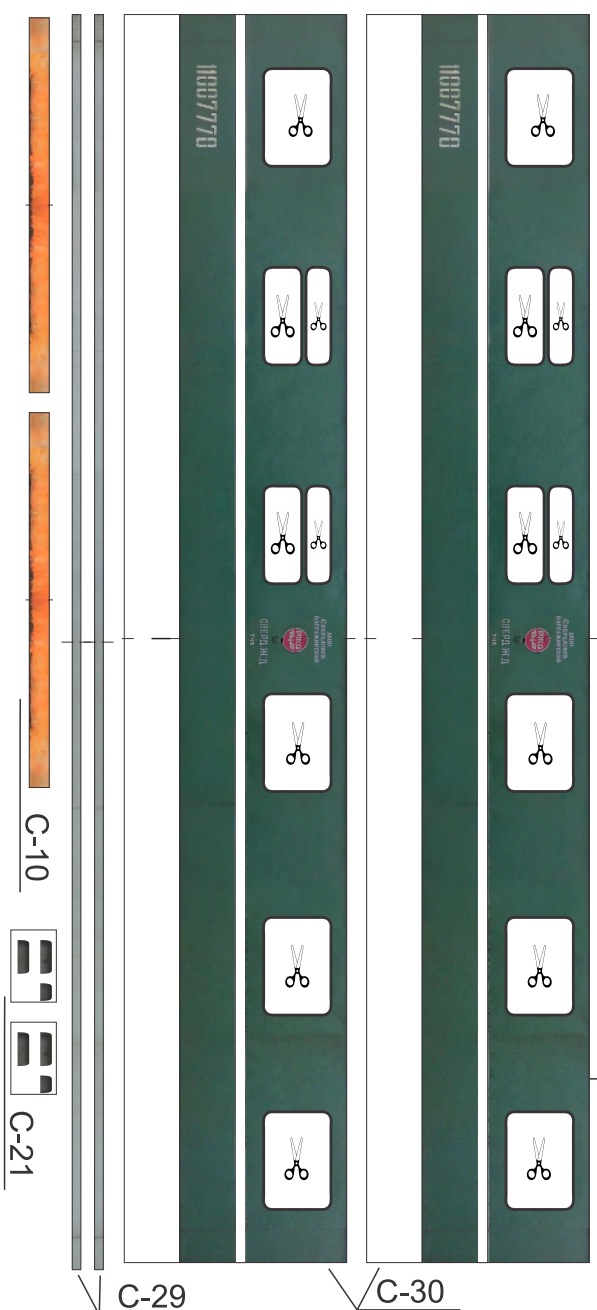
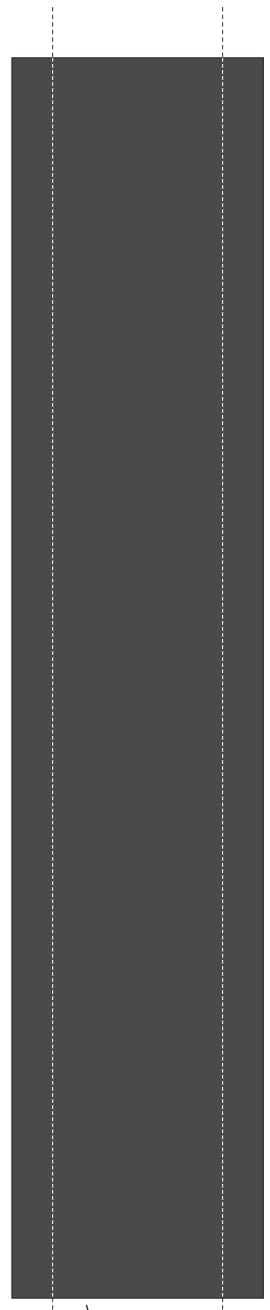
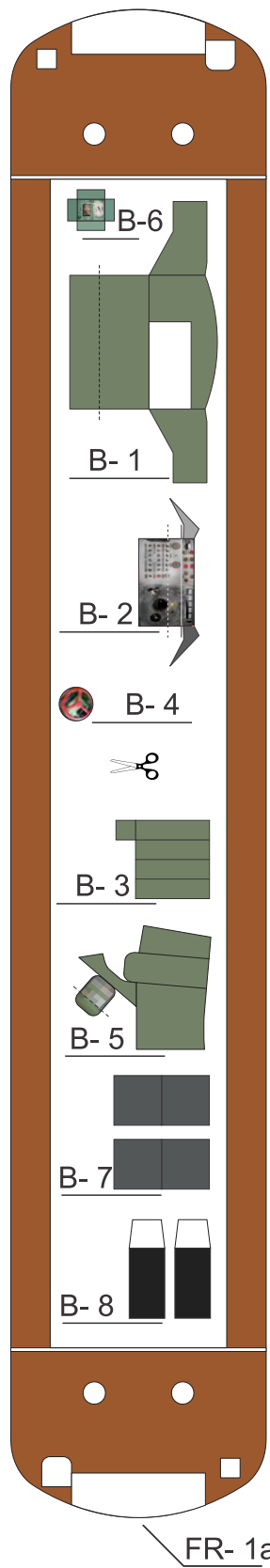
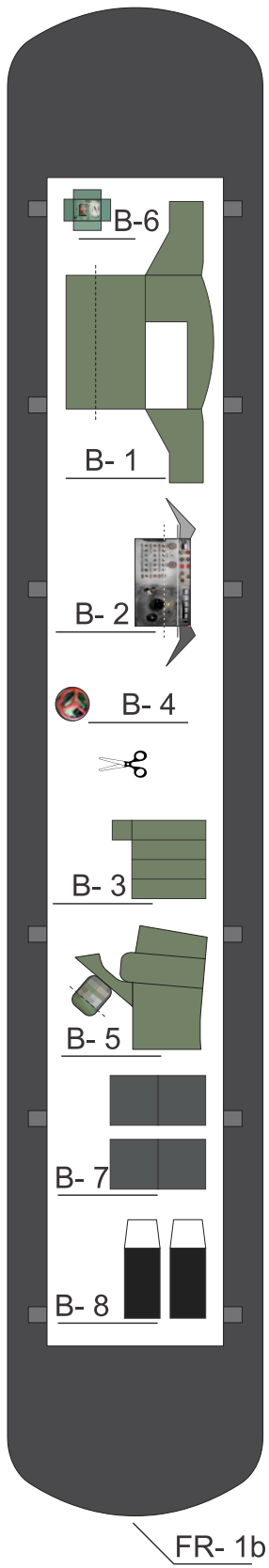

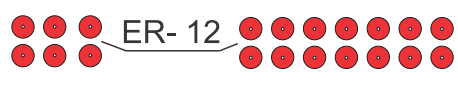
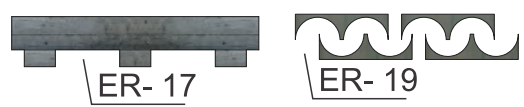
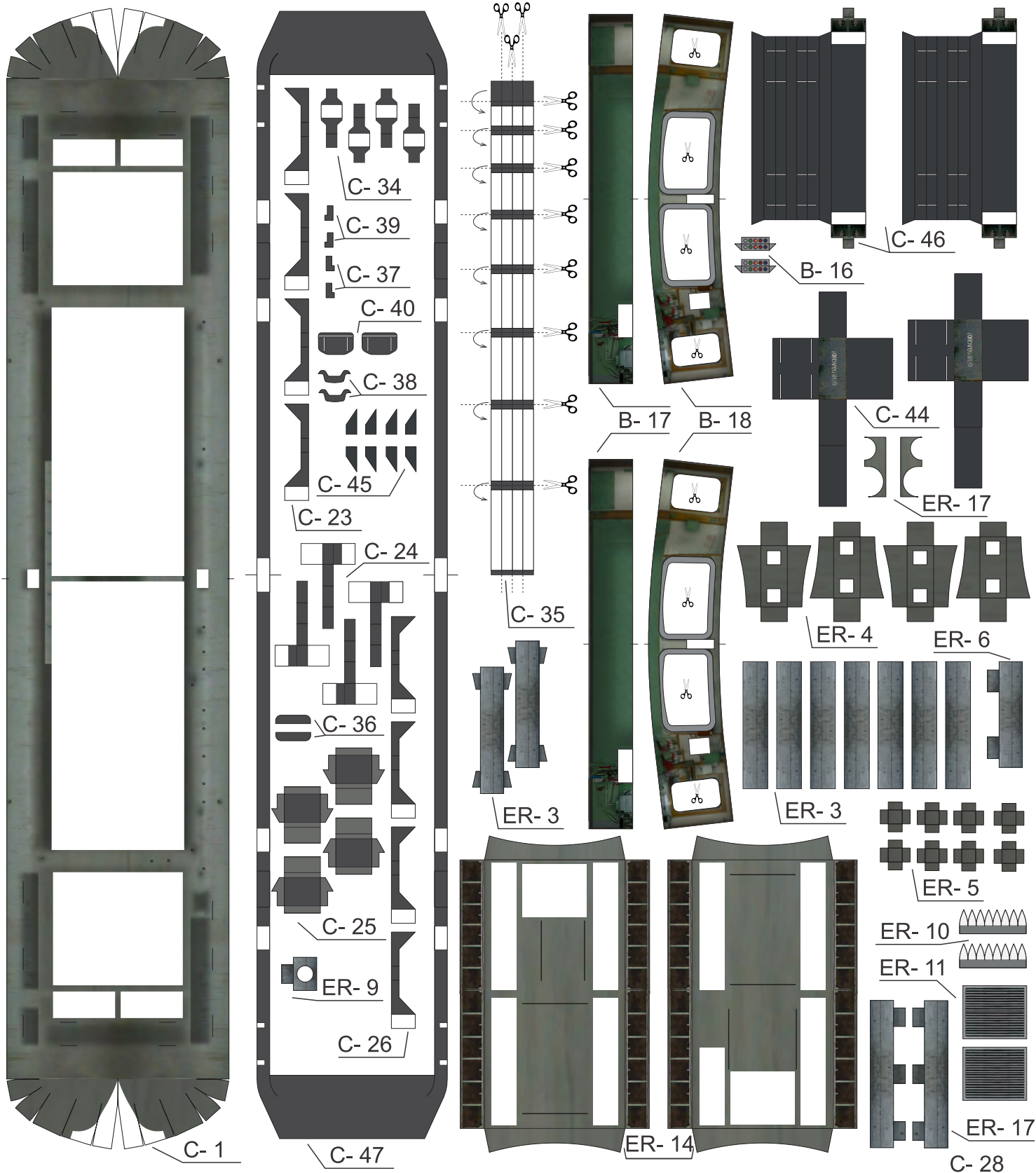

ER-17

C-28

ER-14

ER-16

ER-10

ER-11

ER-5

ER-3

ER-3

ER-4

ER-6

ER-17

C-44

B-16

C-46

B-17

B-18

C-35

C-23

C-24

C-36

C-25

ER-9

C-26

C-47

C-34

C-39

C-37

C-40

C-38

C-45

C-23

C-24

C-36

C-25

ER-9

C-26

C-47

C-34

C-39

C-37

C-40

C-38

C-45

C-23

C-24

C-36

C-25

ER-9

C-26

C-47

C-34

C-39

C-37

C-40

C-38

C-45

C-23

C-24

C-36

C-25

ER-9

C-26

C-47

C-34

C-39

C-37

C-40

C-38

C-45

C-23

C-24

C-36

C-25

ER-9

C-26

C-47

C-34

C-39

C-37

C-40

C-38

C-45

C-23

C-24

C-36

C-25

ER-9

C-26

C-47

C-34

C-39

C-37

C-40

C-38

C-45

C-23

C-24

C-36

C-25

ER-9

C-26

C-47

C-34

C-39

C-37

C-40

C-38

C-45

C-23

C-24

C-36

C-25

ER-9

C-26

C-47

C-34

C-39

C-37

C-40

C-38

C-45

C-23

C-24

C-36

C-25

ER-9

C-26

C-47

C-34

C-39

C-37

C-40

C-38

C-45

C-23

C-24

C-36

C-25

ER-9

C-26

C-47

C-34

C-39

C-37

C-40

C-38

C-45

C-23

C-24

C-36

C-25

ER-9

C-26

C-47

C-34

C-39

C-37

C-40

C-38

C-45

C-23

C-24

C-36

C-25

ER-9

C-26

C-47

C-34

C-39

C-37

C-40

C-38

C-45

C-23

C-24

C-36

C-25

ER-9

C-26

C-47

C-34

C-39

C-37

C-40

C-38

C-45

C-23

C-24

C-36

C-25

ER-9

C-26

C-47

C-34

C-39

C-37

C-40

C-38

C-45

C-23

C-24

C-36

C-25

ER-9

C-26

C-47

C-34

C-39

C-37

C-40

C-38

C-45

C-23

C-24

C-36

C-25

ER-9

C-26

C-47

C-34

C-39

C-37

C-40

C-38

C-45

C-23

C-24

C-36

C-25

ER-9

C-26

C-47

C-34

C-39

C-37

C-40

C-38

C-45

C-23

C-24

C-36

C-25

ER-9

C-26

C-47

C-34

C-39

C-37

C-40

C-38

C-45

C-23

C-24

C-36

C-25

ER-9

C-26

C-47

C-34

C-39

C-37

C-40

C-38

C-45

C-23

C-24

C-36

C-25

ER-9

C-26

C-47

C-34

C-39

C-37

C-40

C-38

C-45

C-23

C-24

C-36

C-25

ER-9

C-26

C-47

C-34

C-39

C-37

C-40

C-38

C-45

C-23

C-24

C-36

C-25

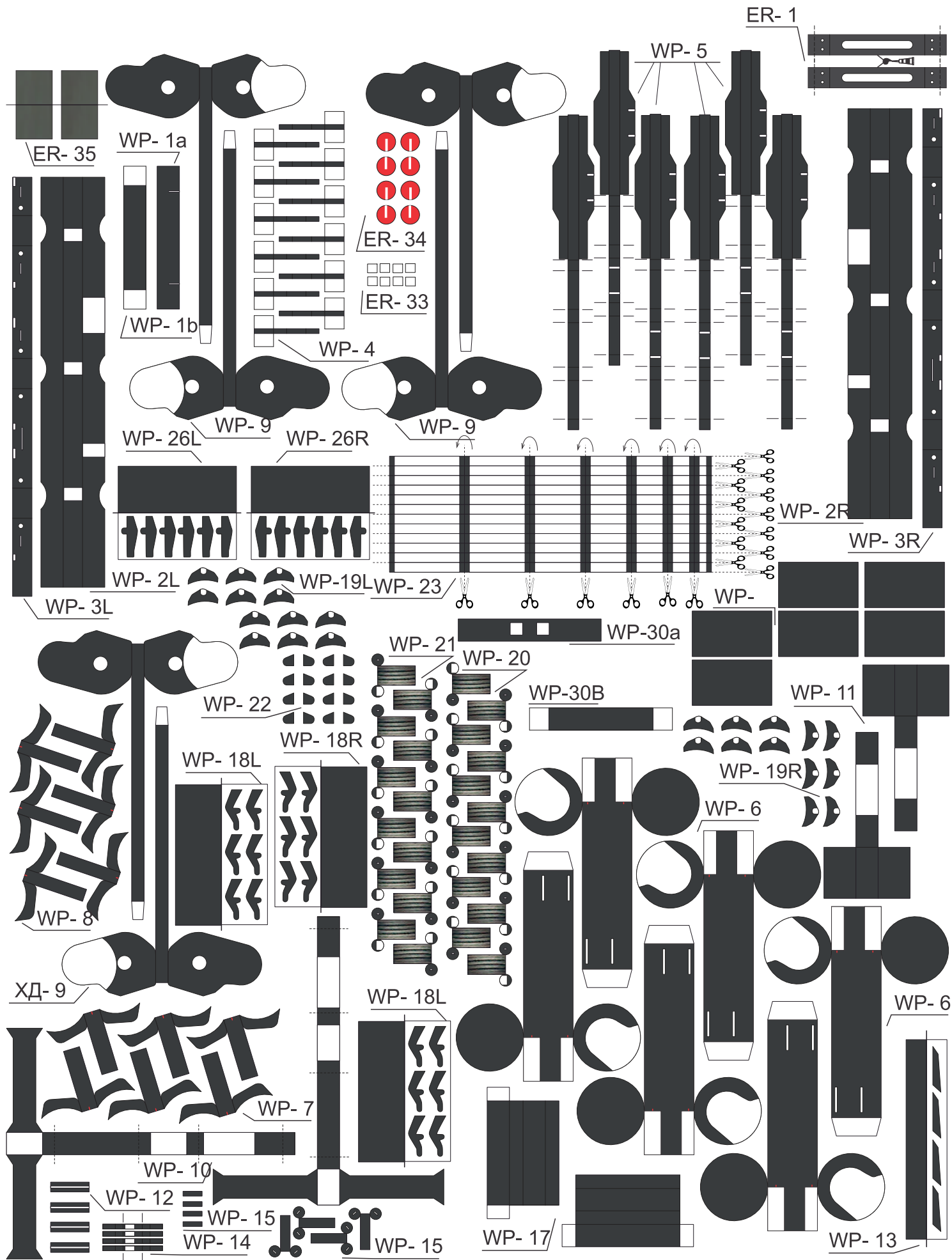

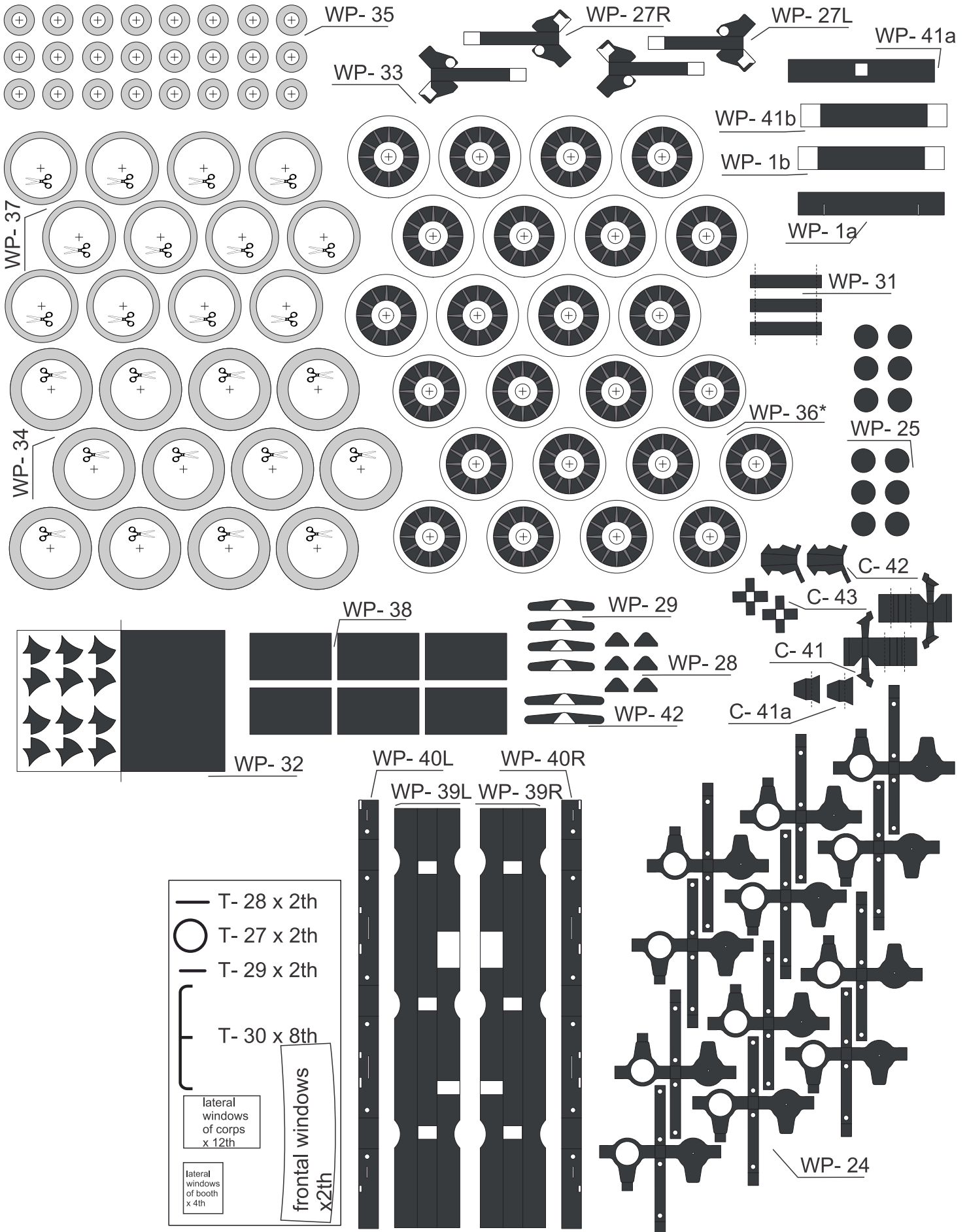

templates of details from a wire

