

Вариант Б

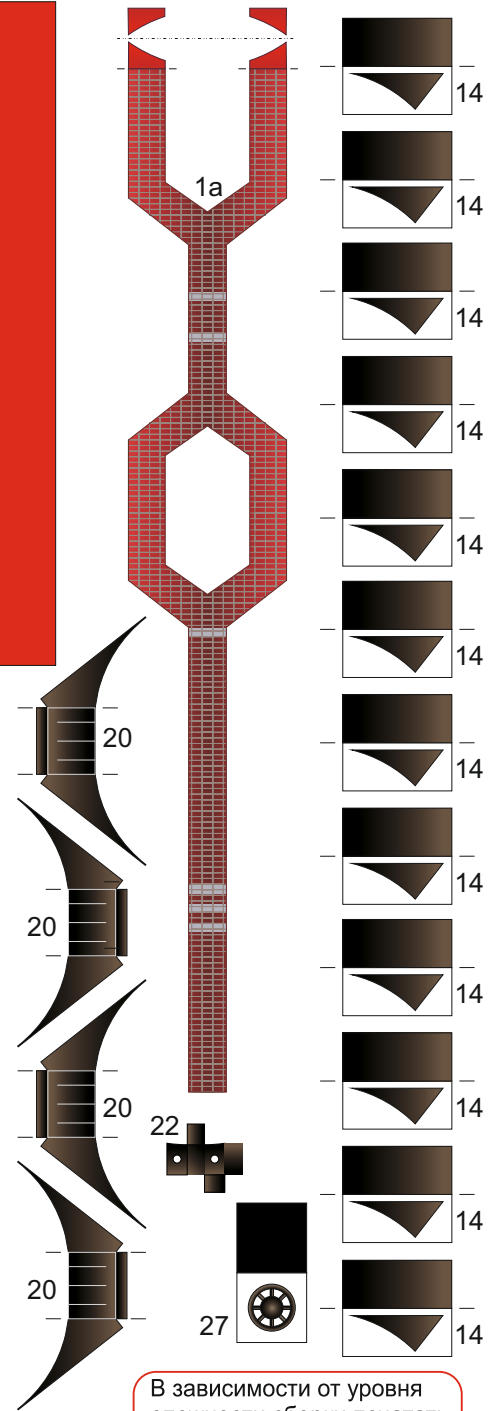

Лист 2 - вариант Б

В зависимости от уровня сложности сборки печатать либо Лист 2 вариант А, либо Лист 2 вариант Б

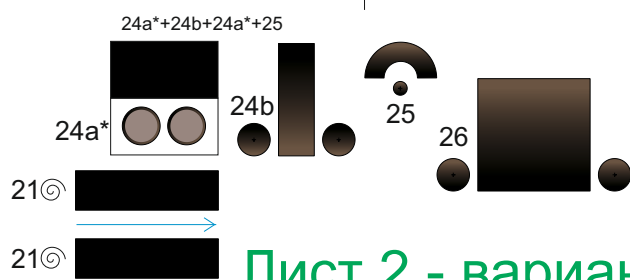
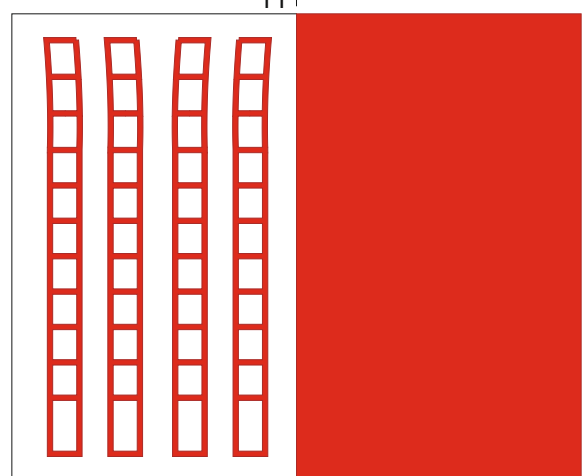
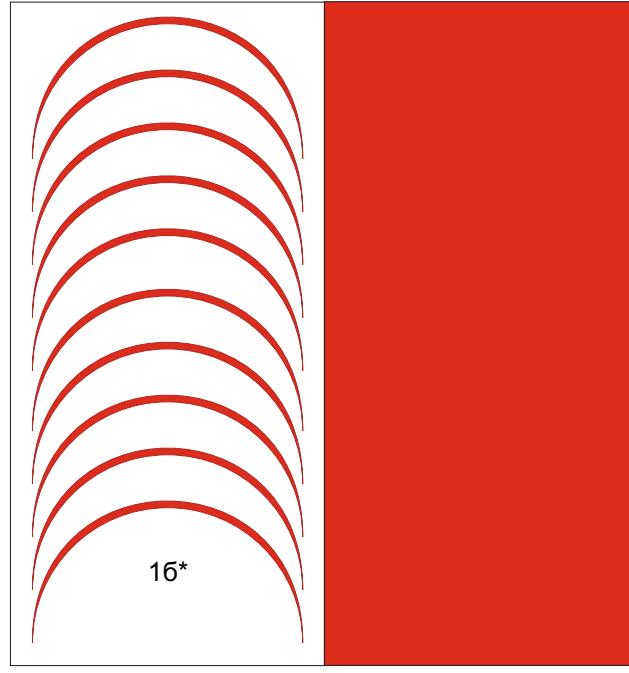
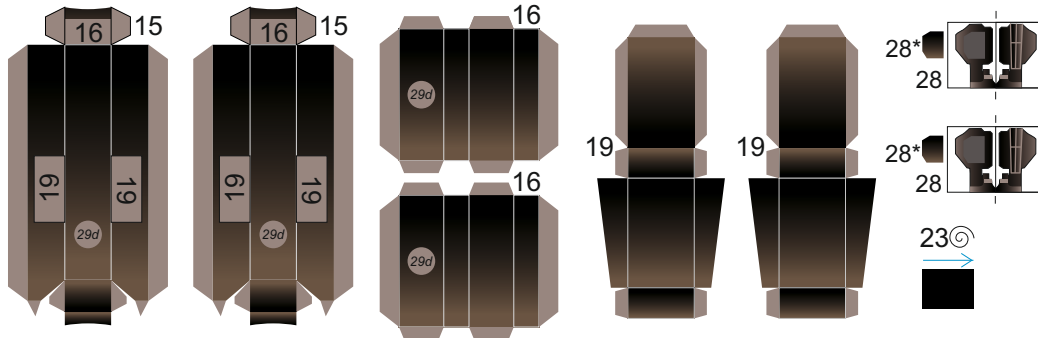
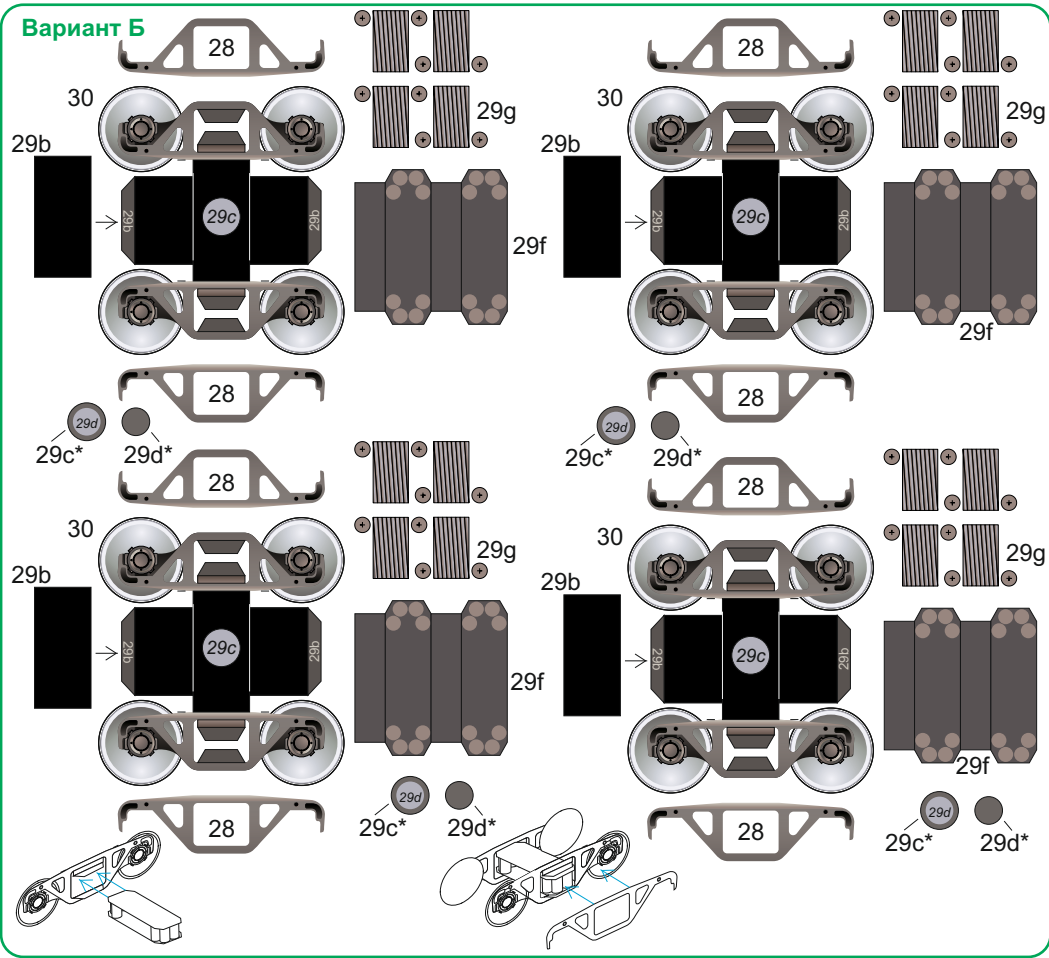
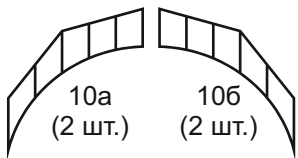
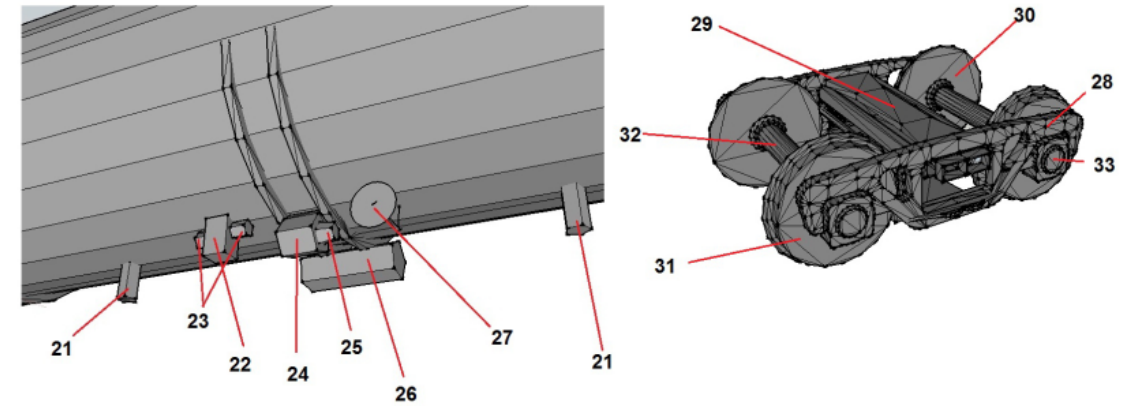
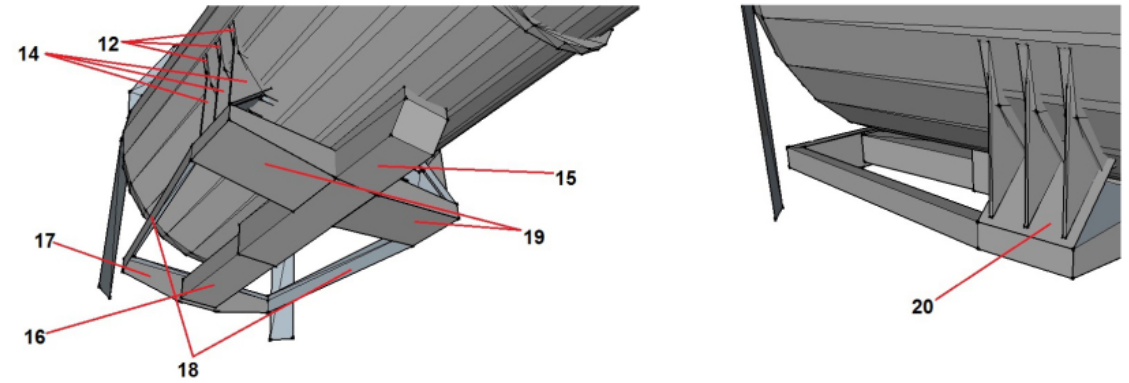
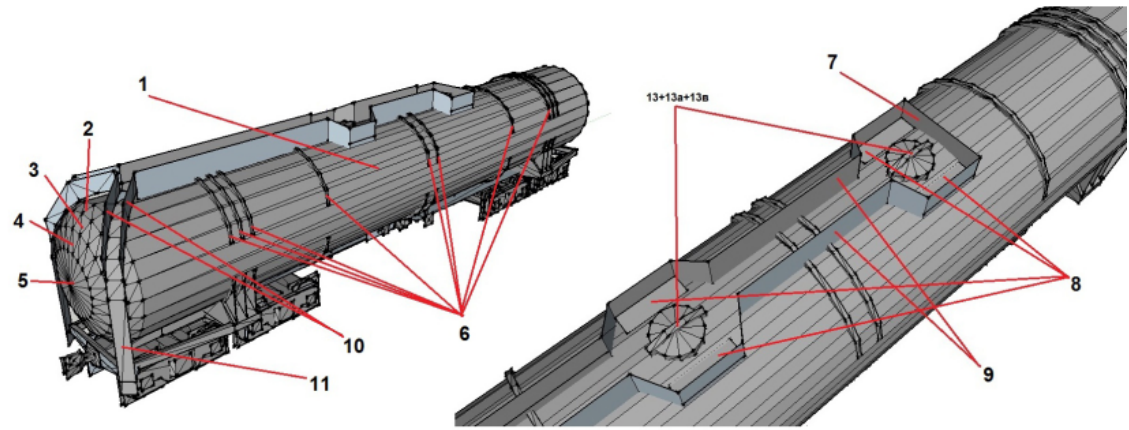
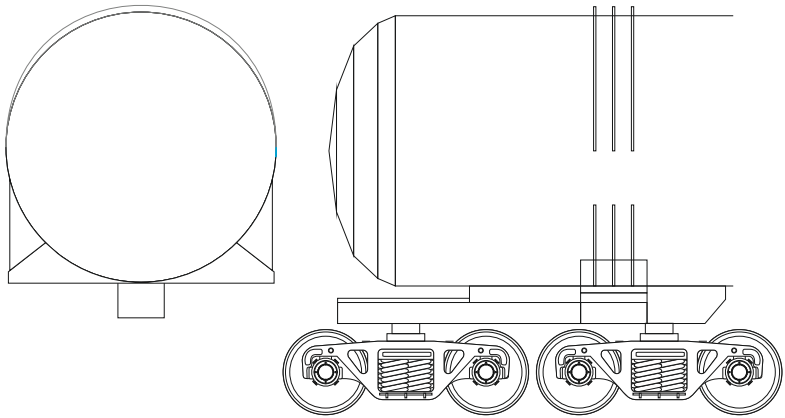

выполнить из проволоки

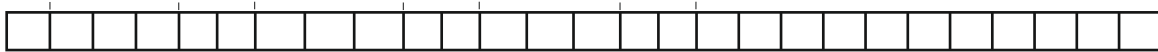

выполнить из проволоки и согнуть по данному образцу

7(2 шт.)

**Векторная обработка модели
8-осного вагона-цистерны (автор - Дегтярёв)
Масштаб 1:87**