

KARTONOWY ARSENAŁ

NIEMIECKI CIĄGNIK ARTYLERYJSKI

Sd.Kfz.7

(8 ton SEMI TRACK)

1:25



8-9/96

ISSN 1831-8477



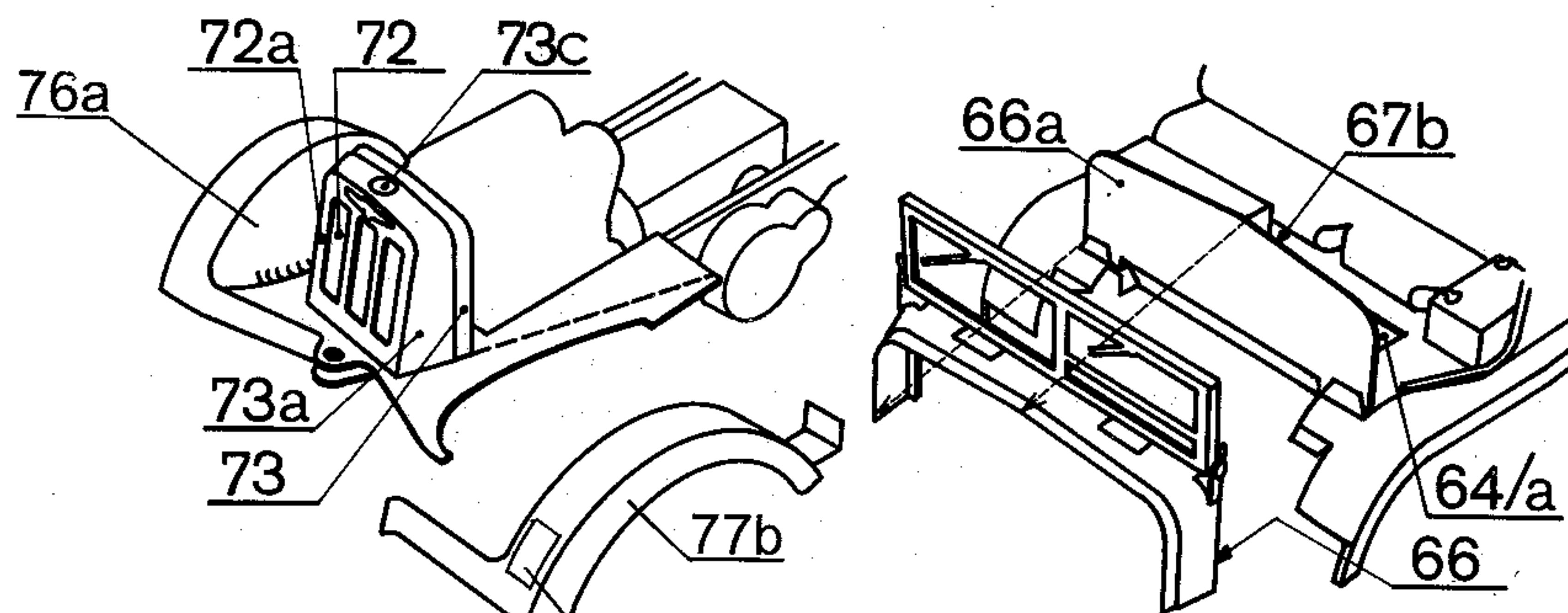
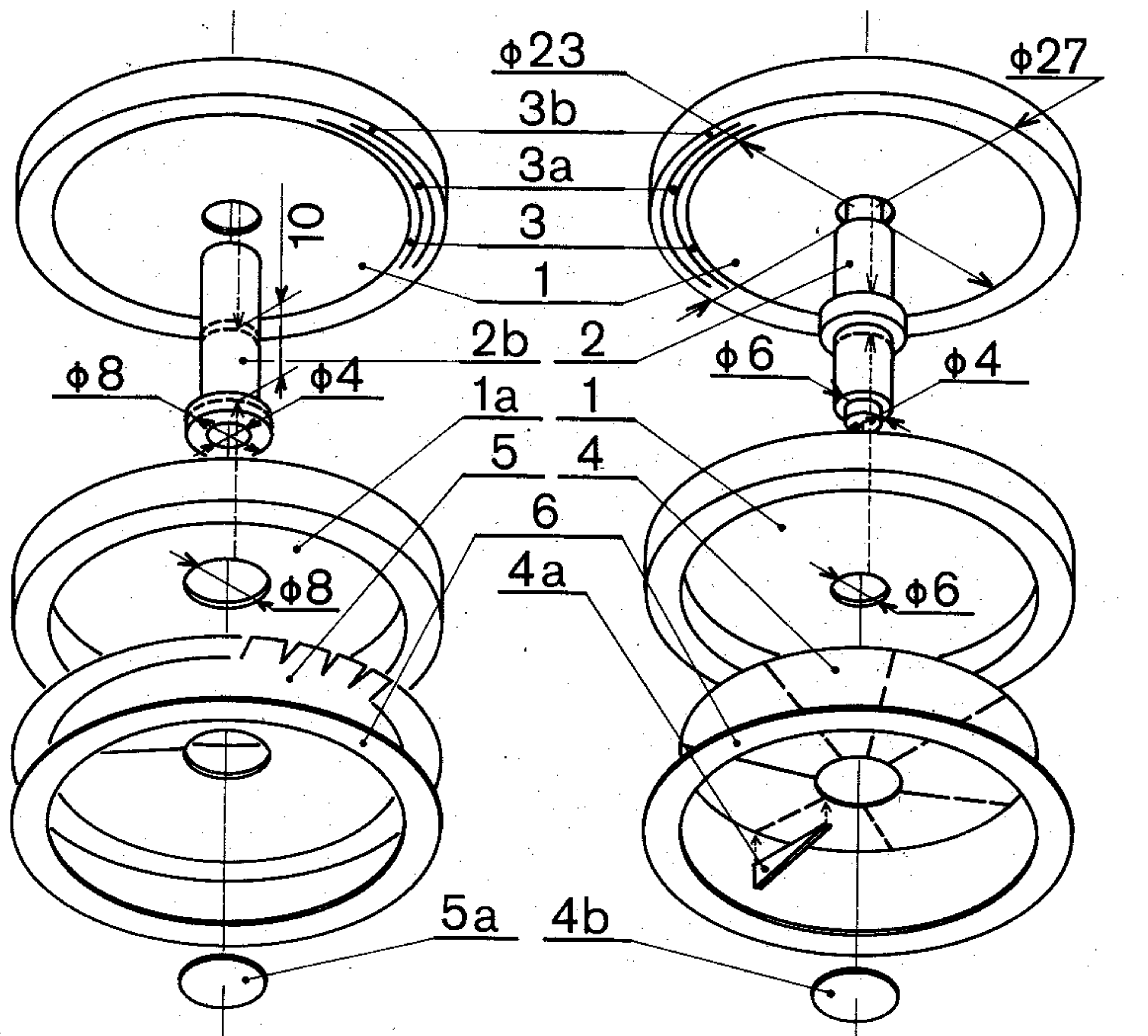

Znak jednotki
cz.77 cz.53b

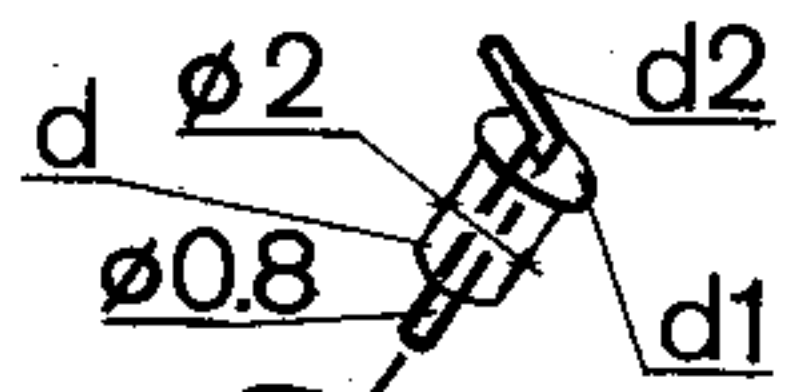
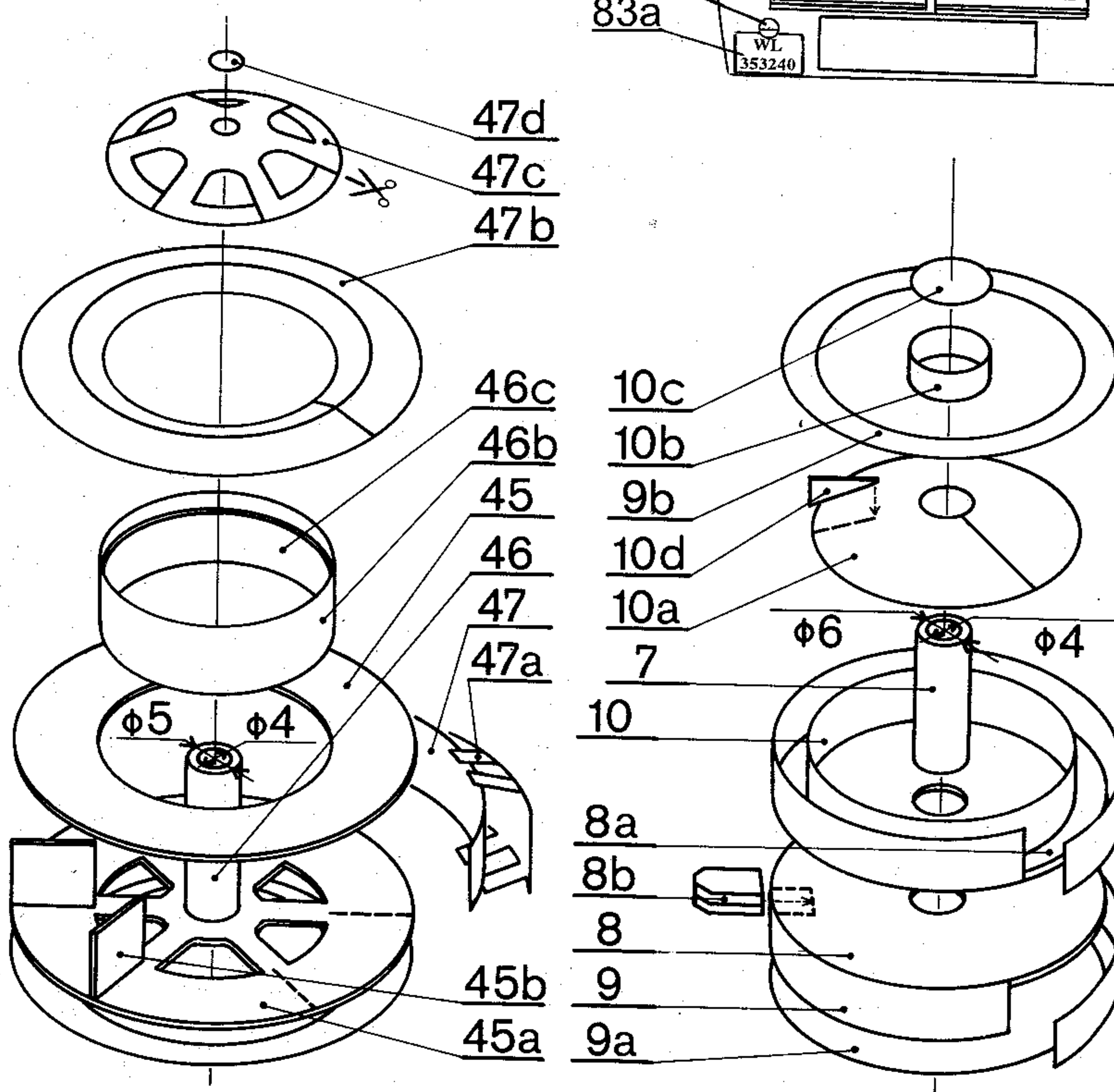
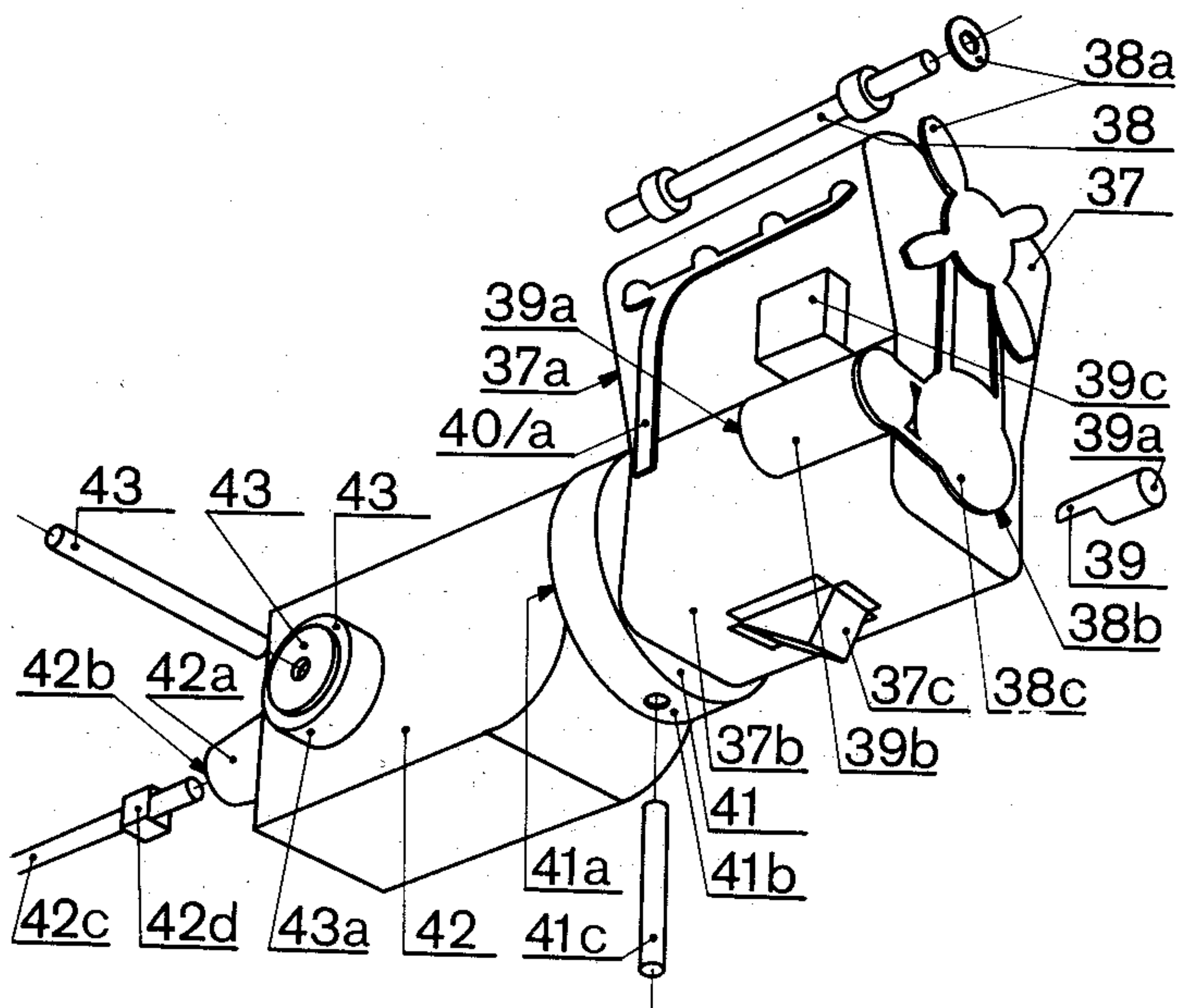
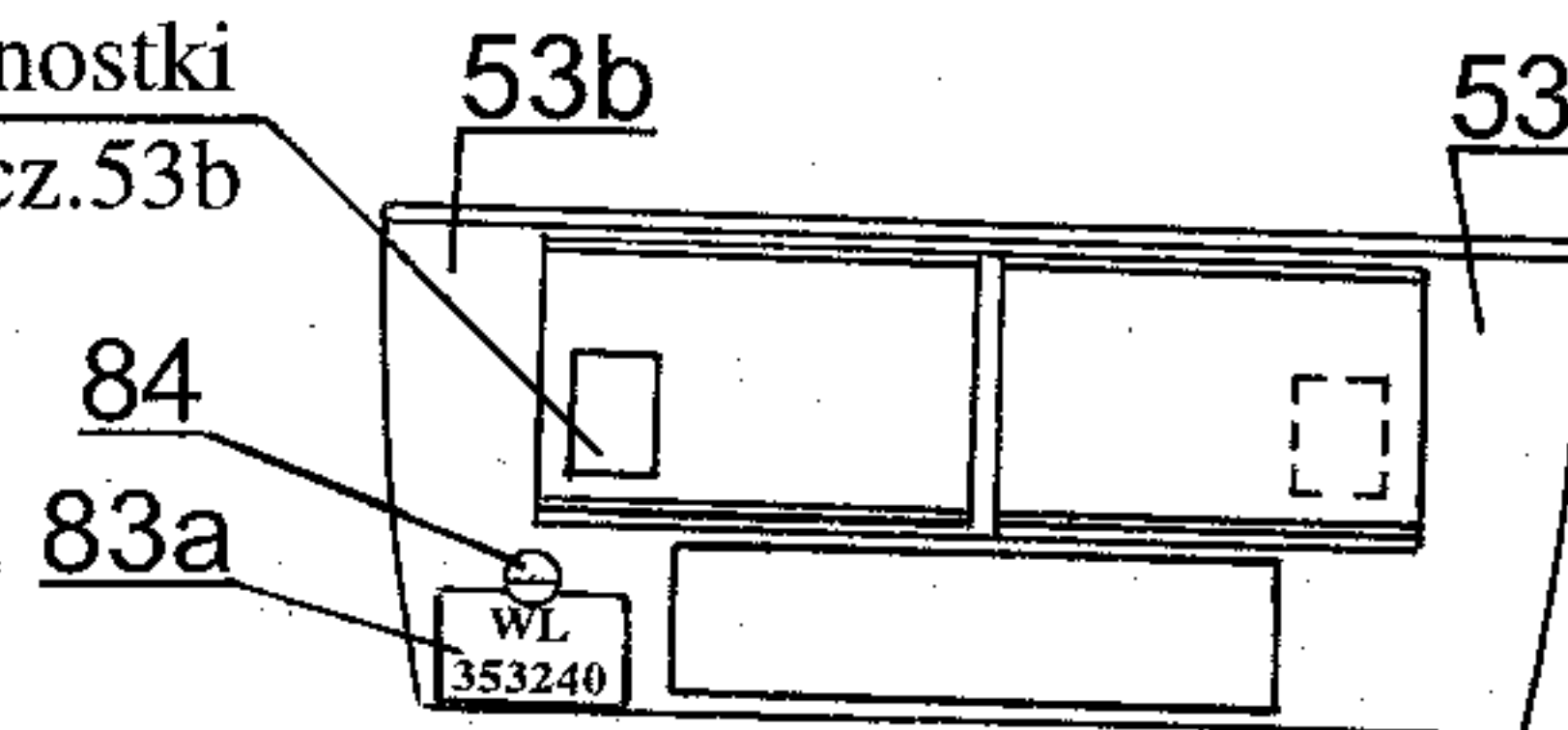

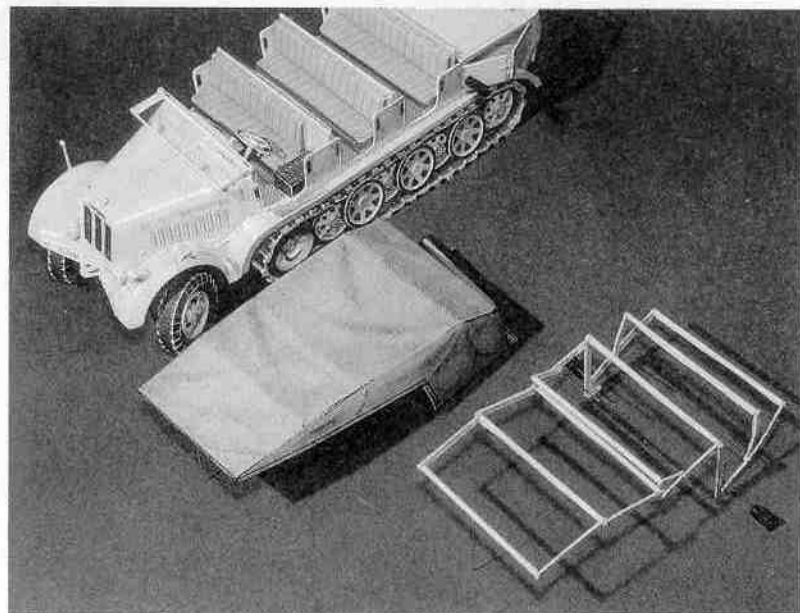
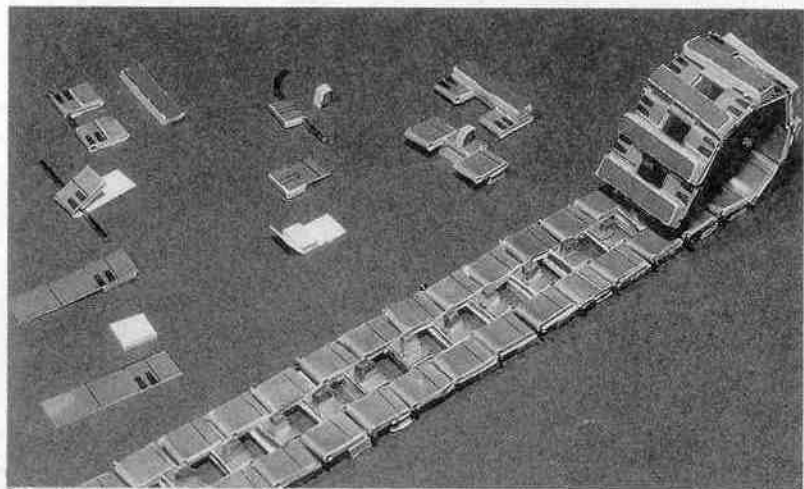
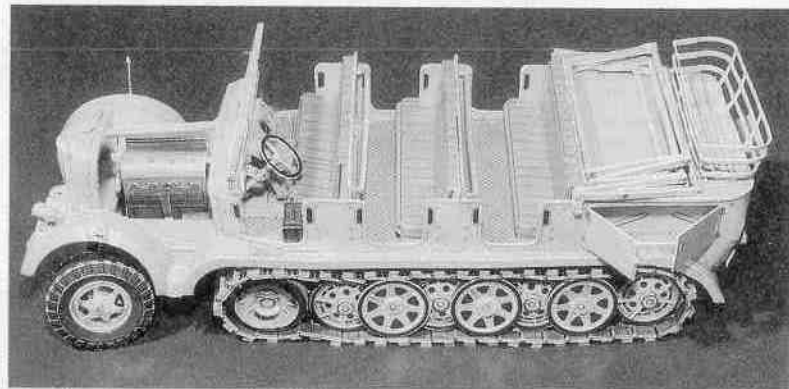
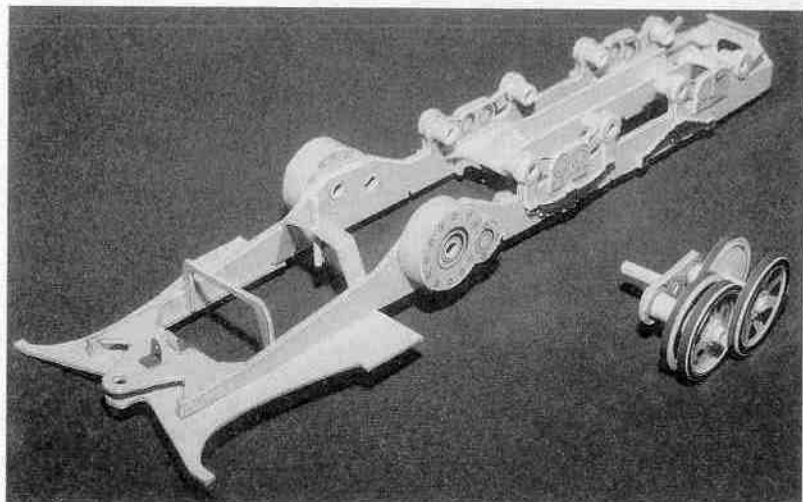
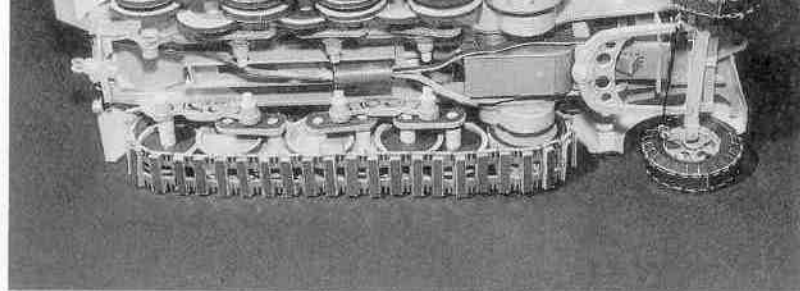
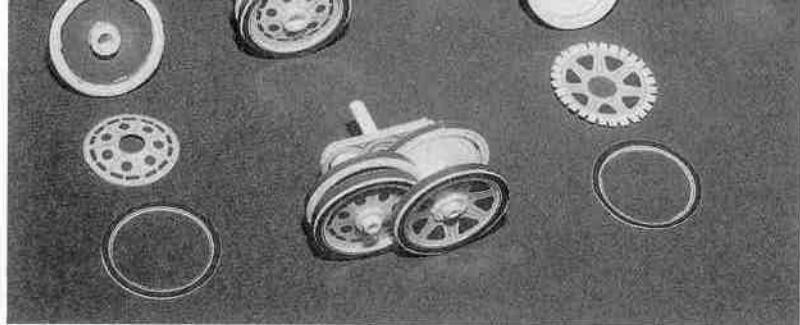

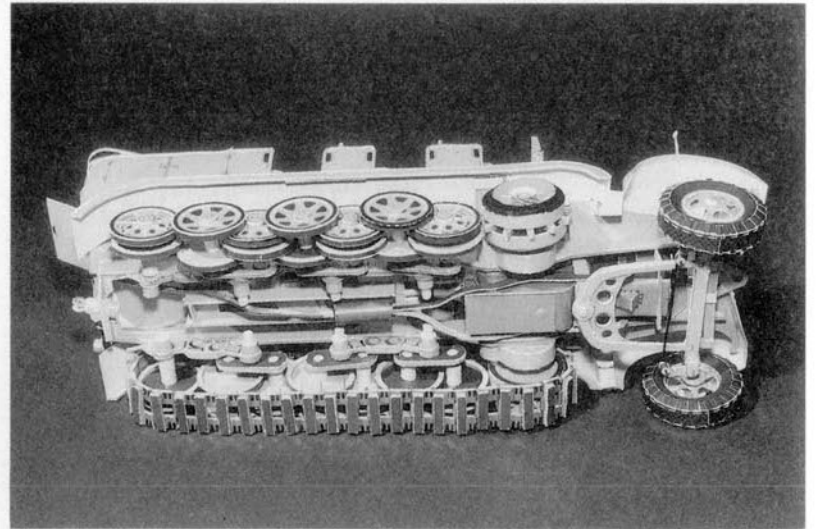
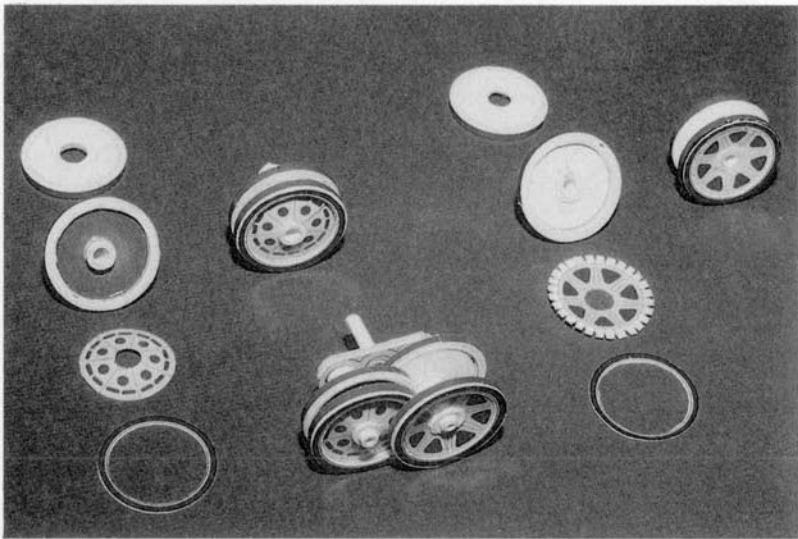
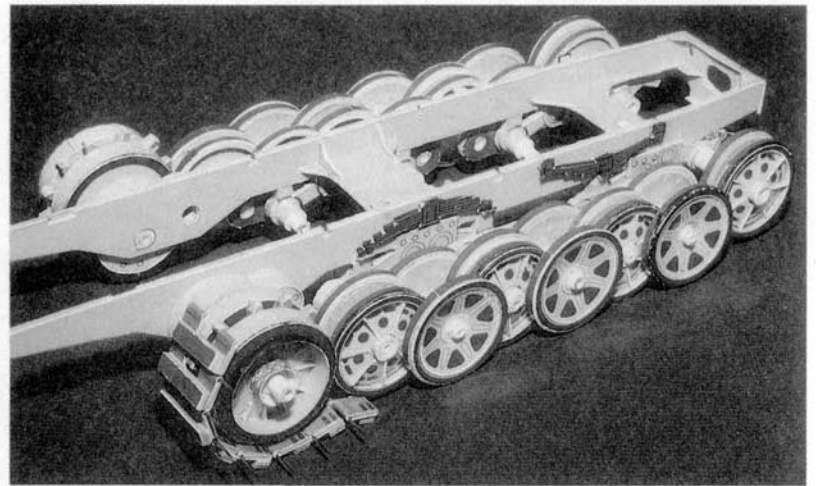
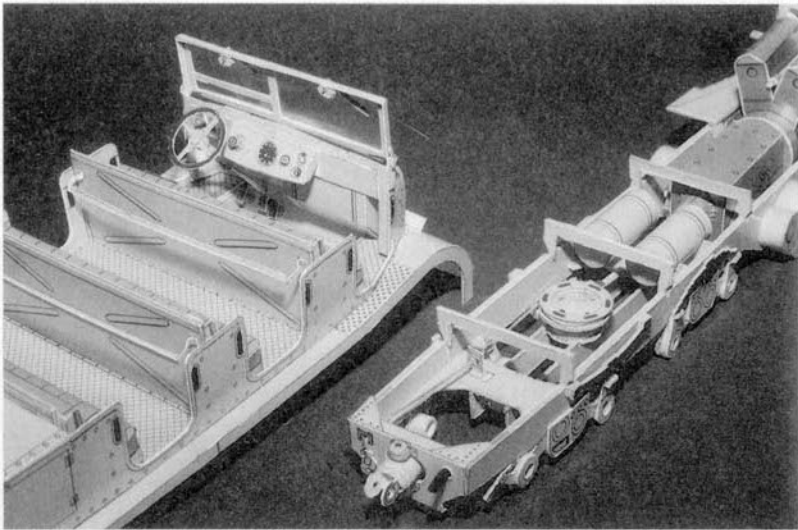

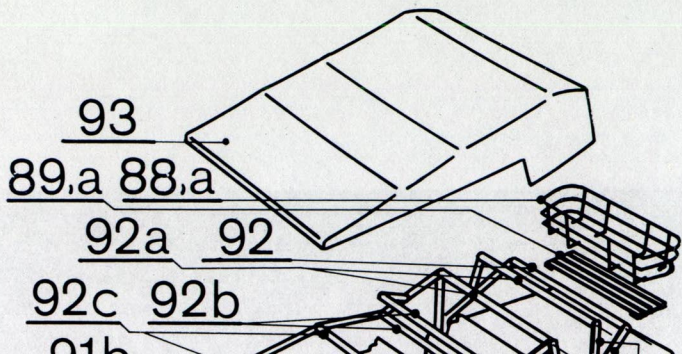
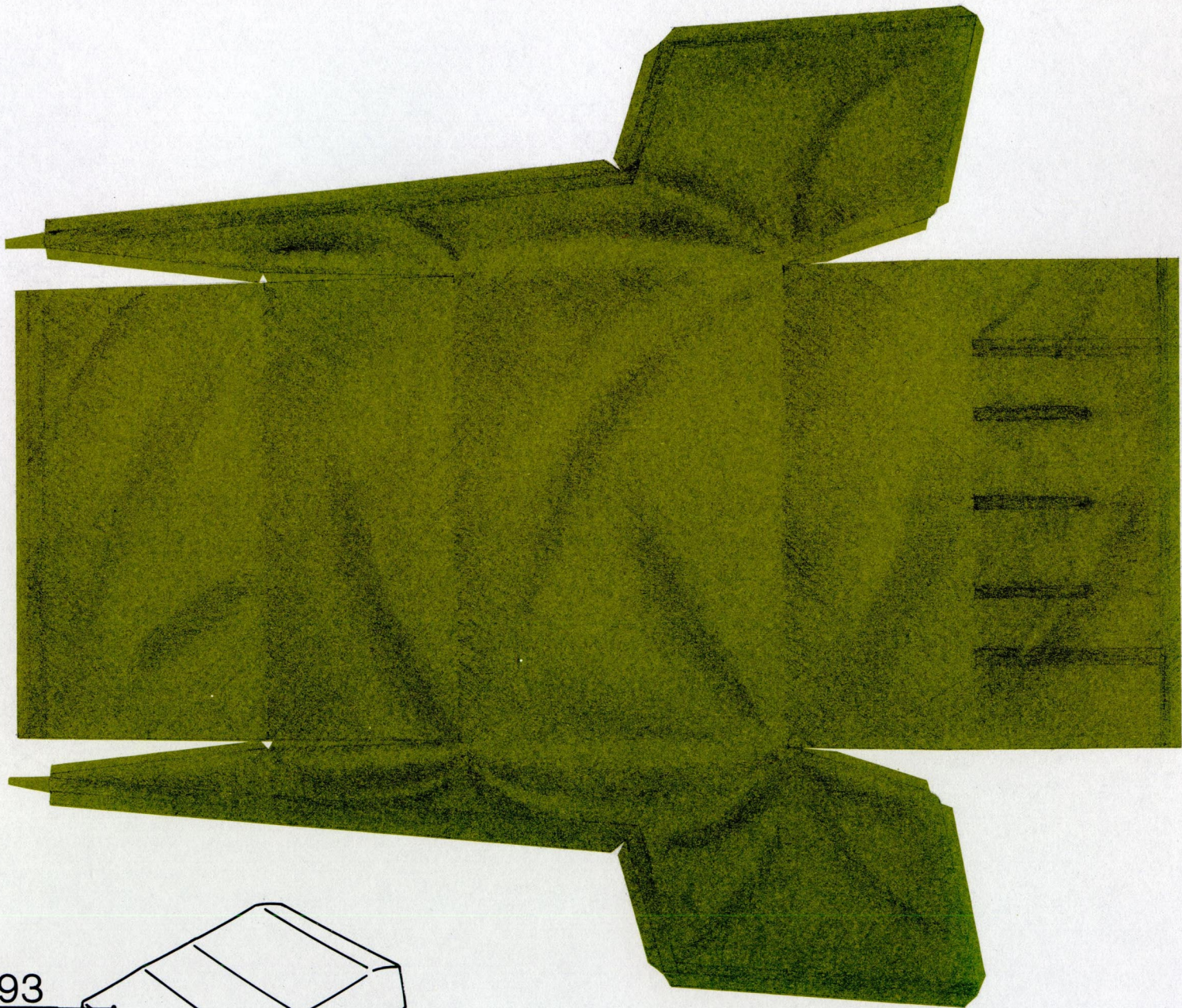

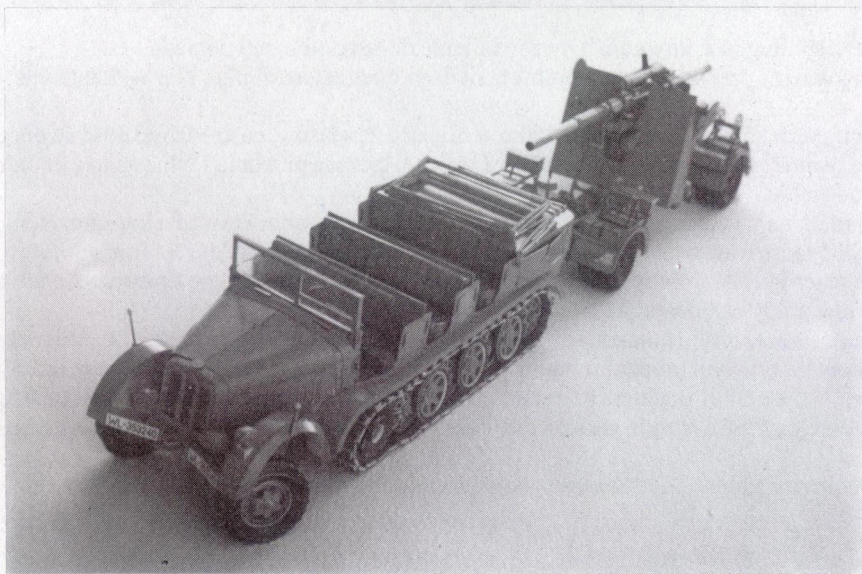
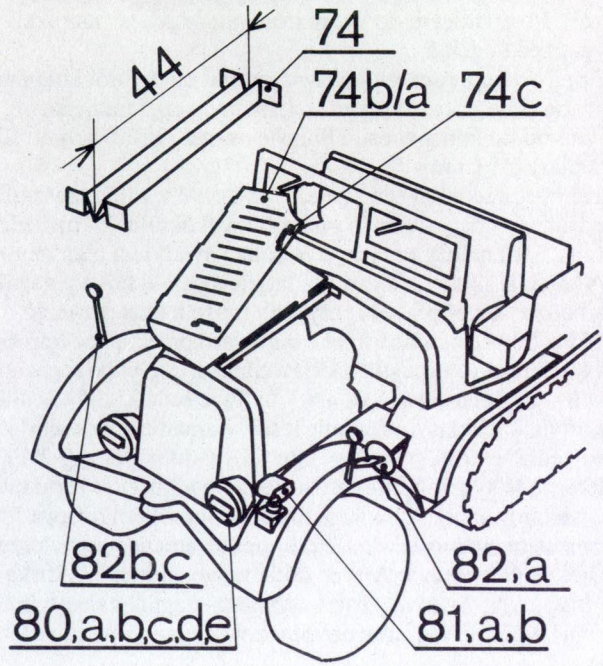
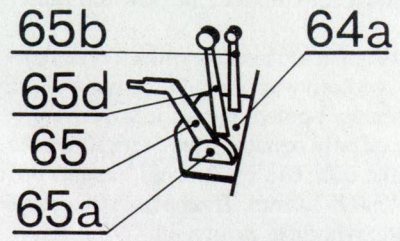
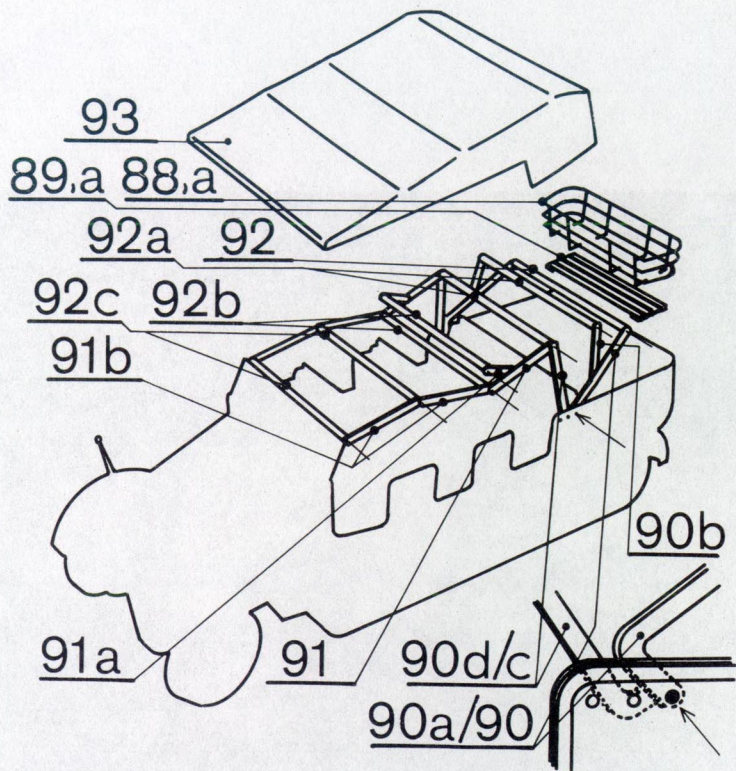



Model jest przeznaczony dla modelarzy doświadczonych. Jest to model efektowny, niezbyt skomplikowany i trudny. Staranne wykonanie kilkunastu kół czy prawie setki ogniów gąsienicy jest jednak pracochłonne i żmudne, co mniej wytrwałych może zniechęcić do dalszej pracy. Z tych względów do klejenia tego modelu nie powinni zabierać się modelarze początkujący.



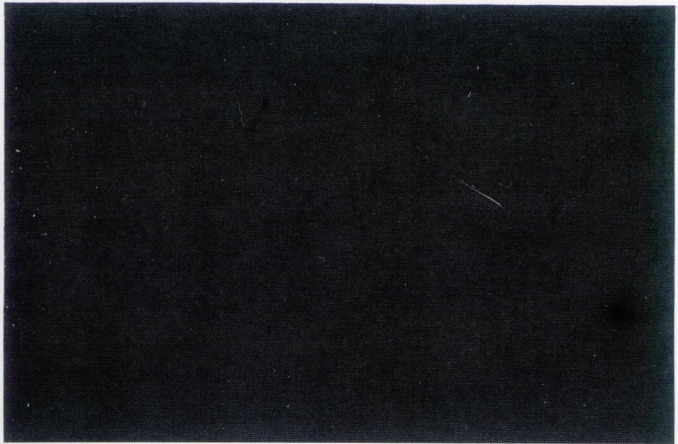

K.



REZERWA

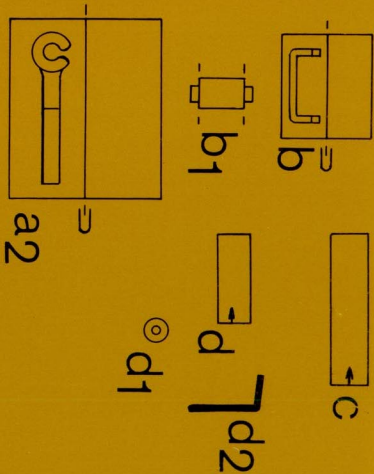
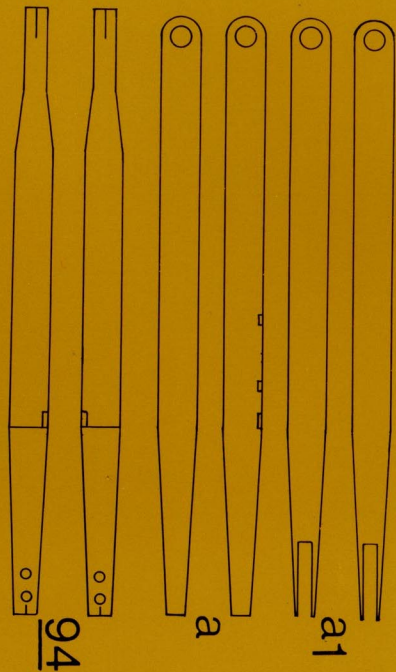
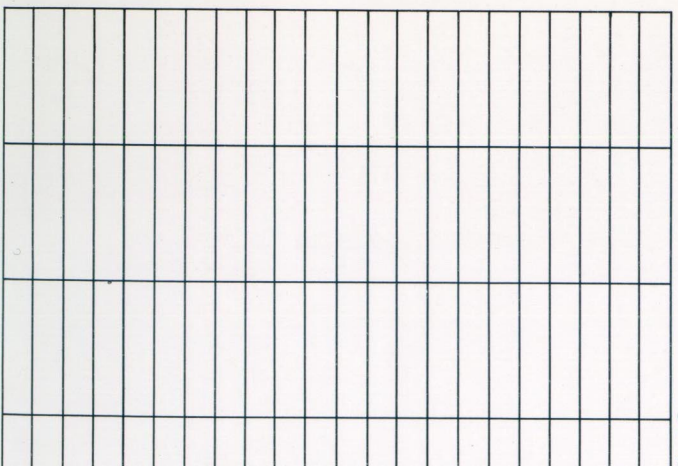
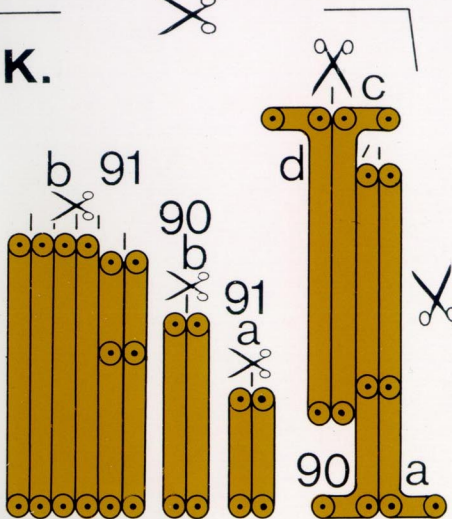

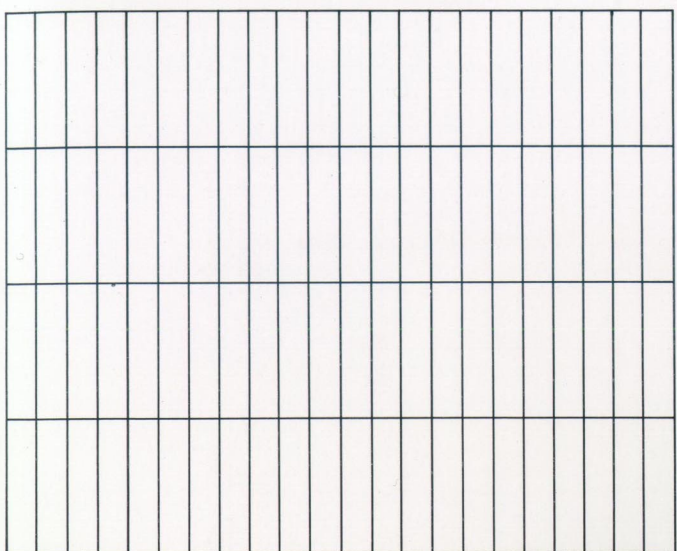

15

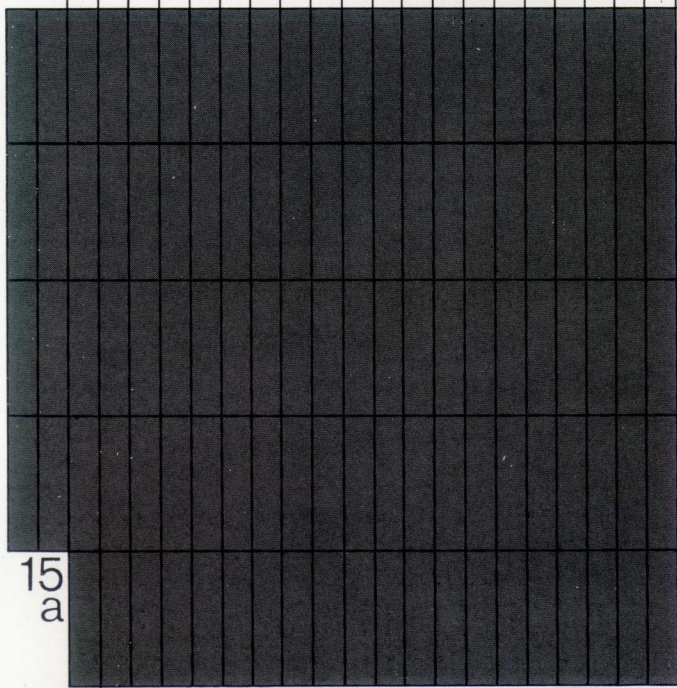

15
a

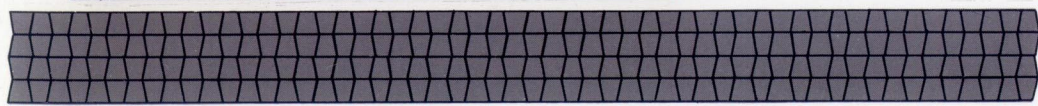

16



11



13

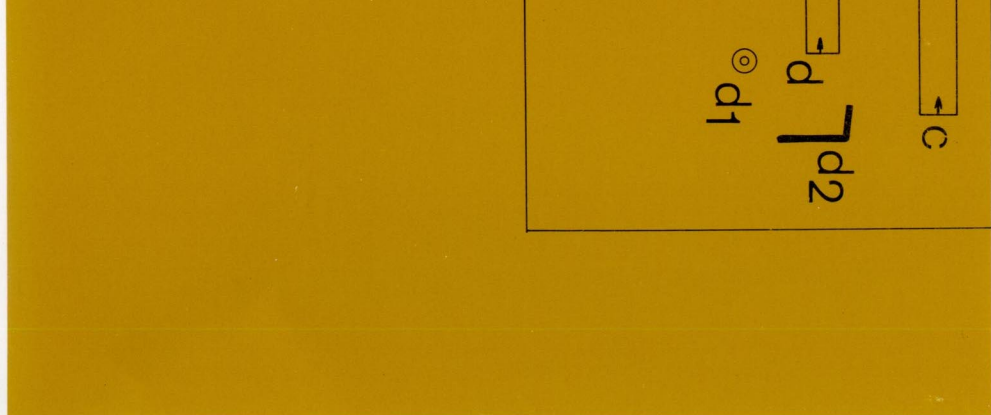

d_1
 d_2

c

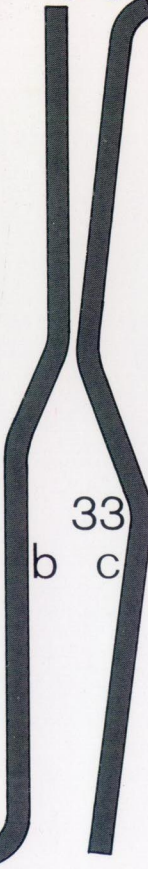
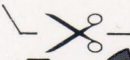

33

b

c

23b



29c

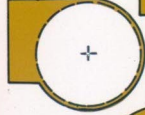

31

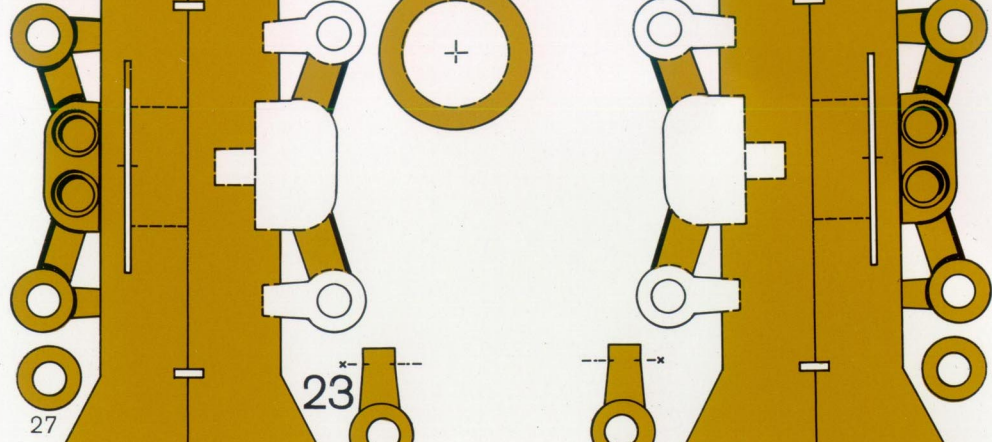
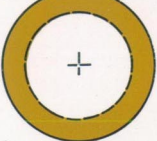

27

23



29 a



24



26

b

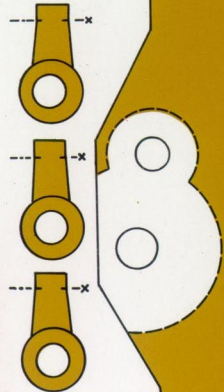

25

b

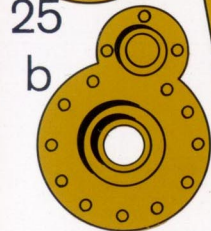

17 a

1a

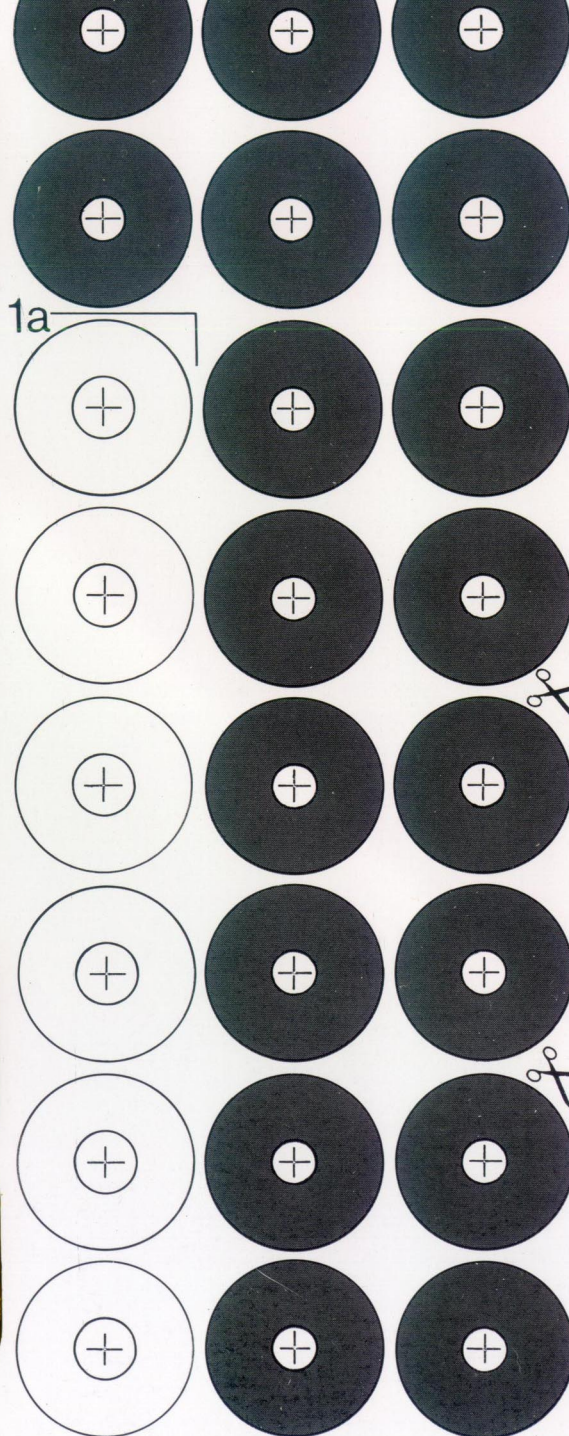
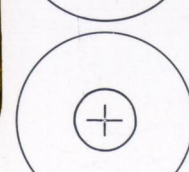
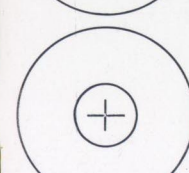
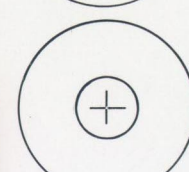
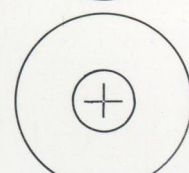
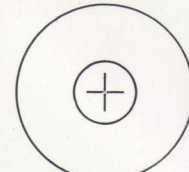

8b

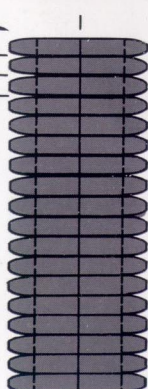
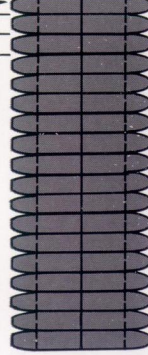

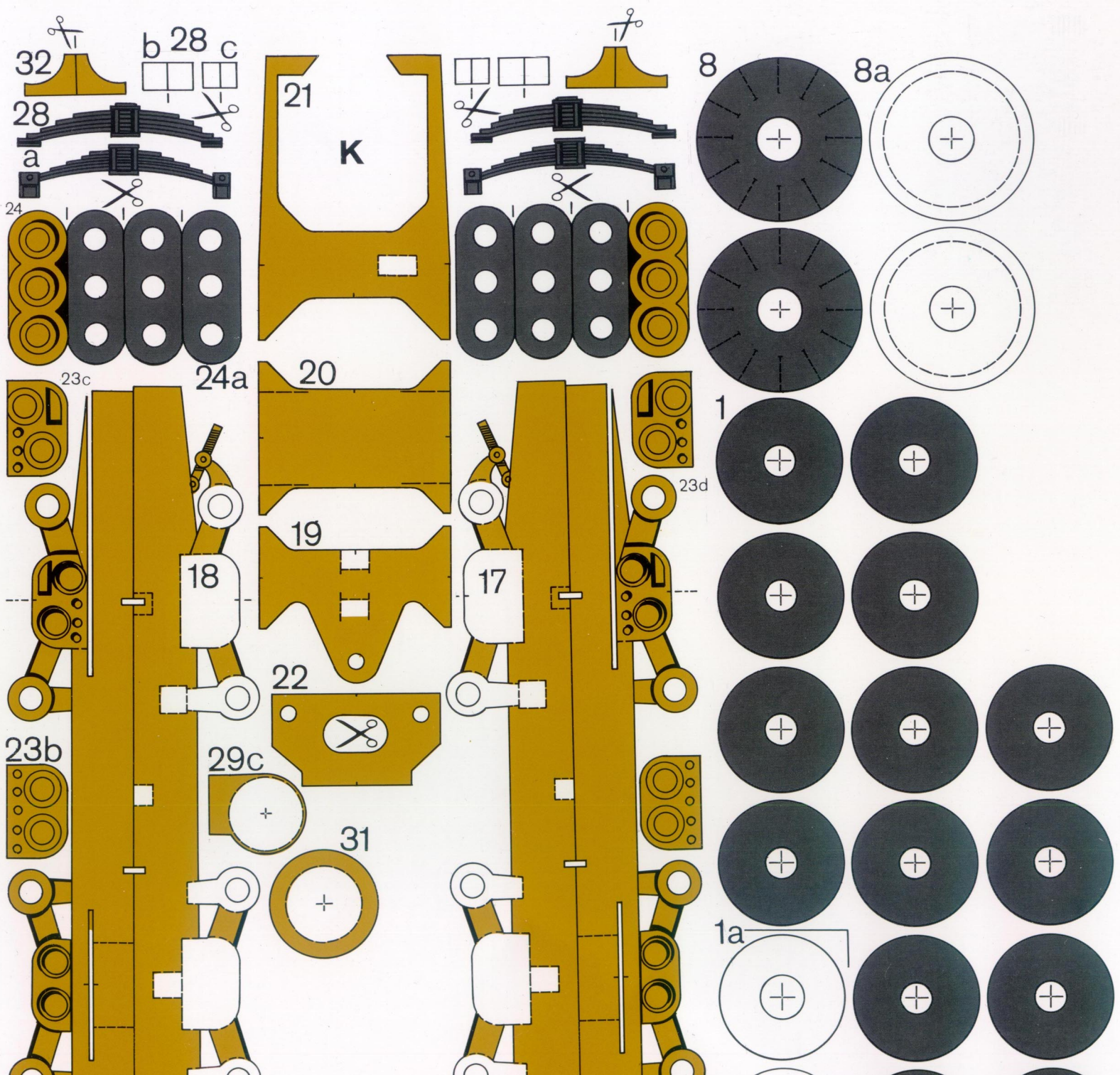

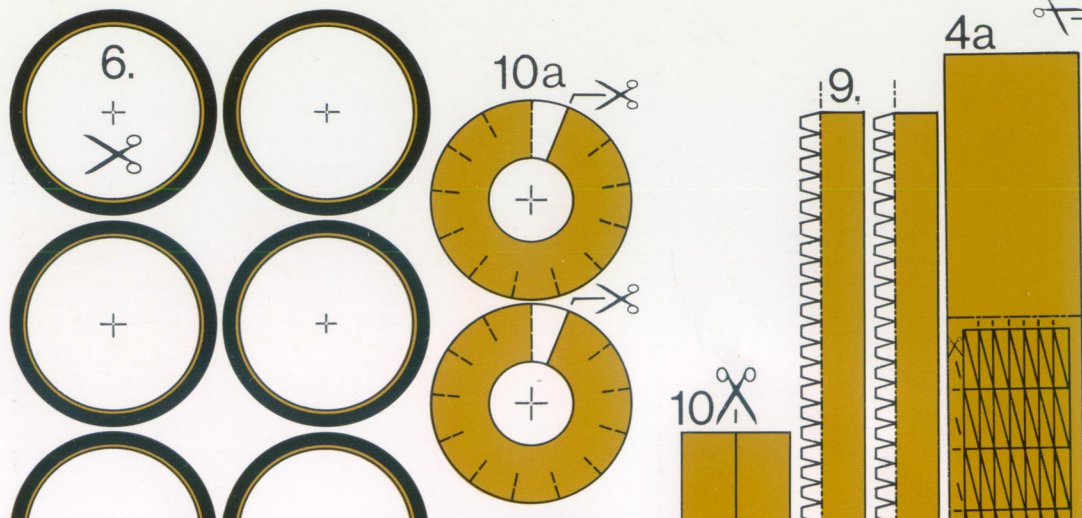
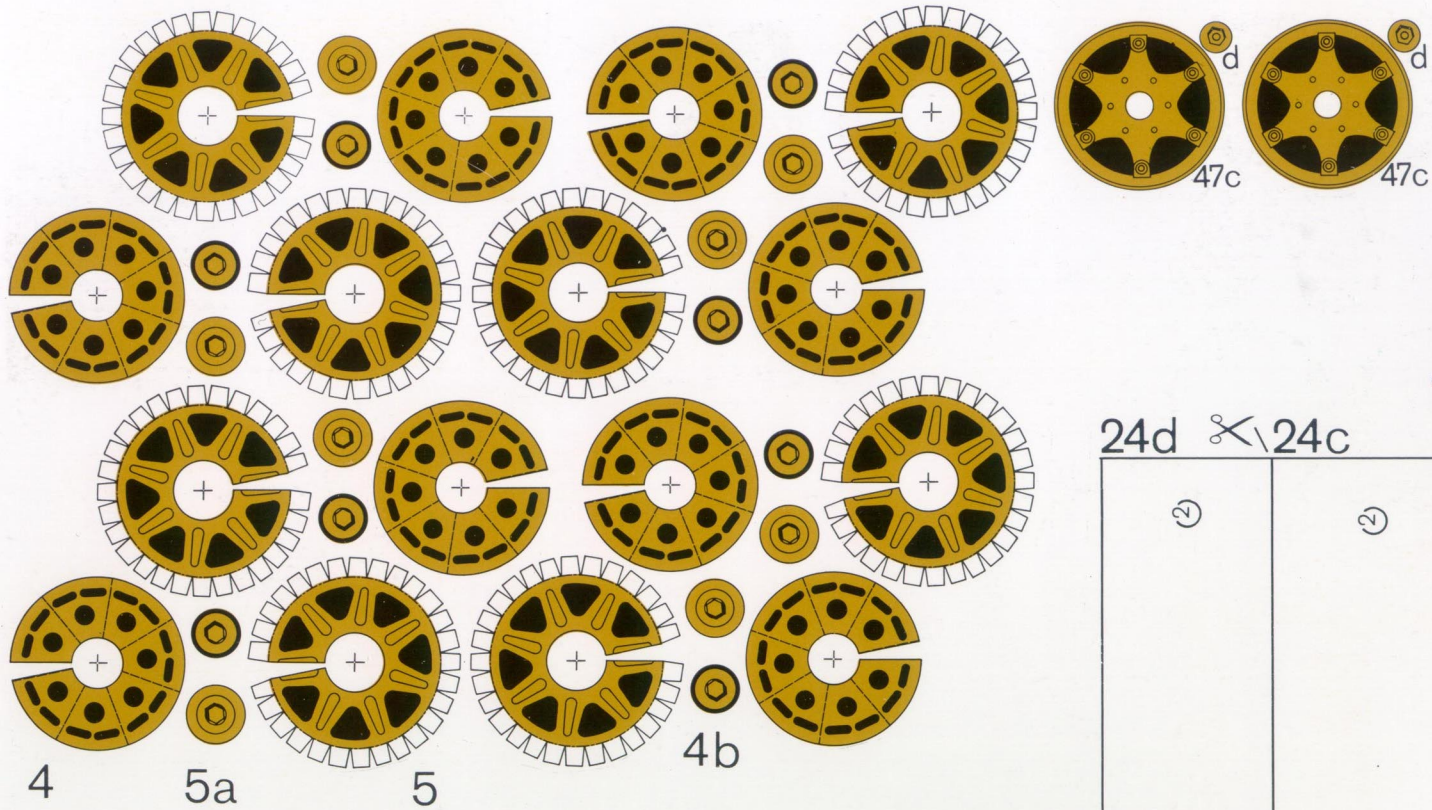

24d \times 24c



⑤

⑤

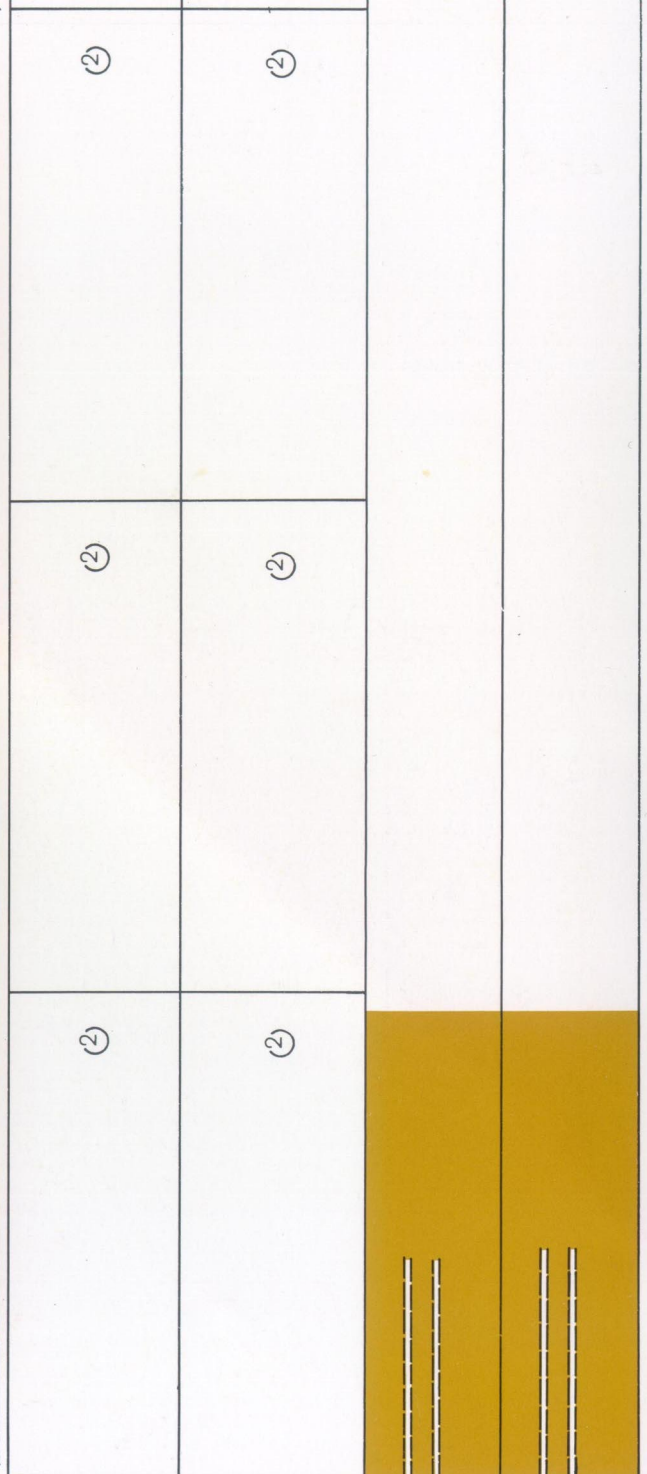
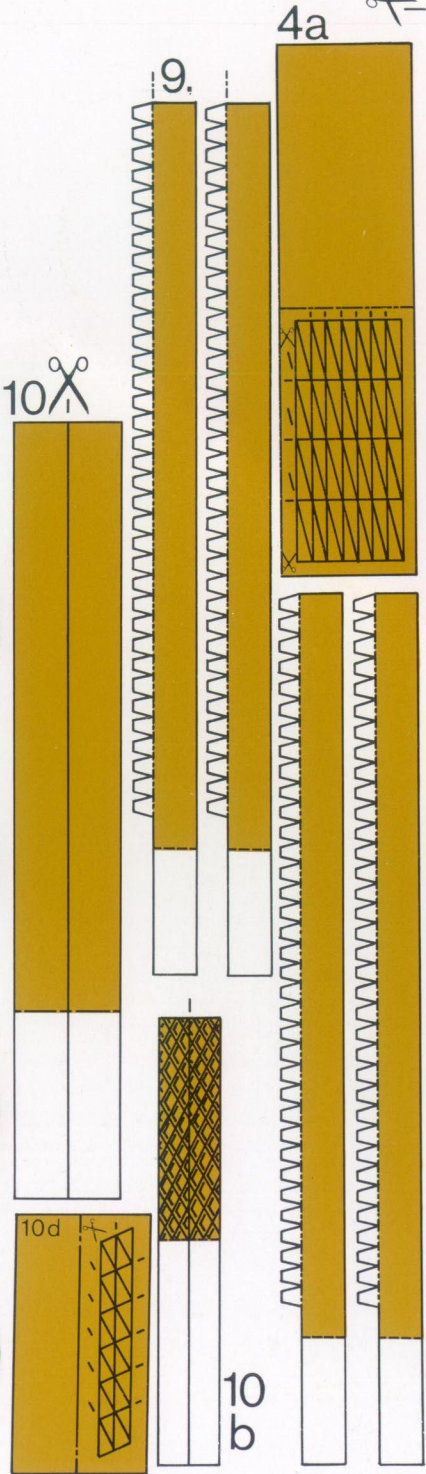
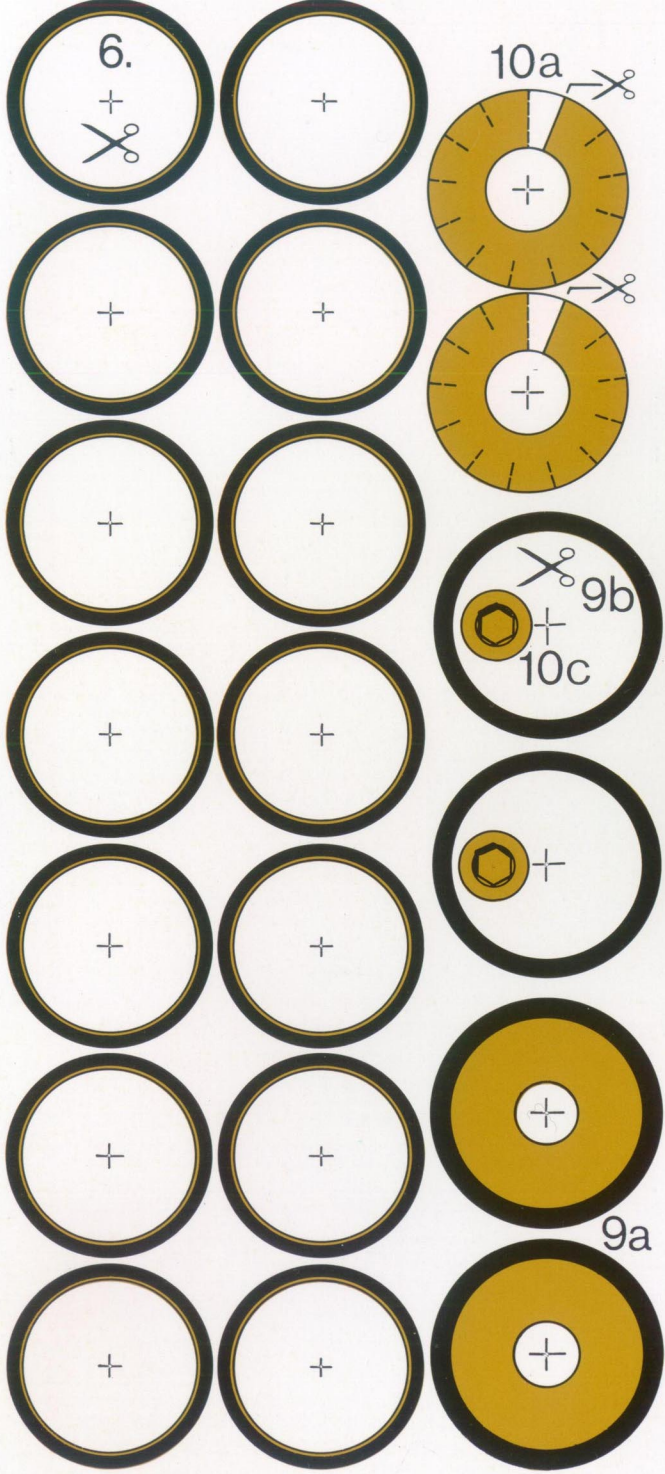

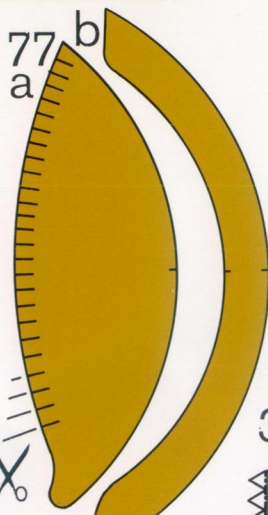
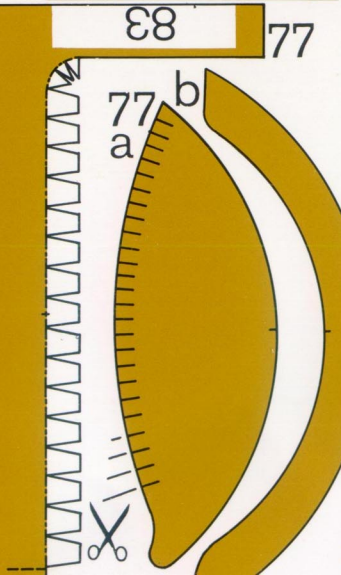
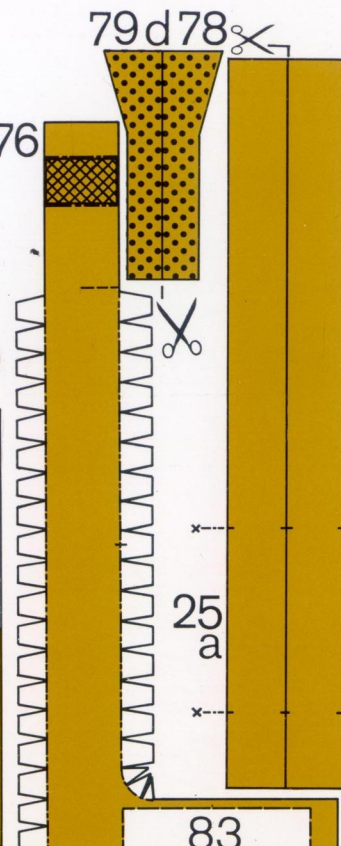
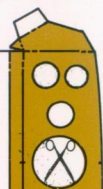
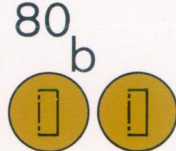
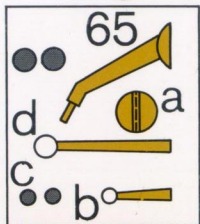
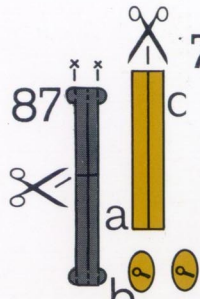
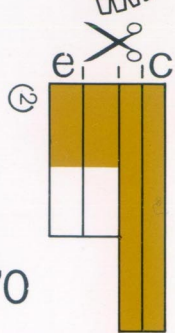
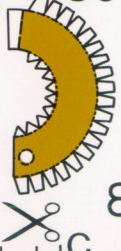
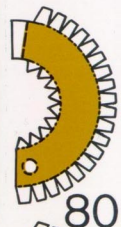
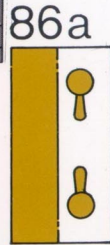
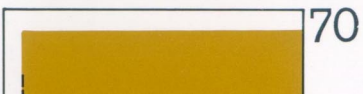
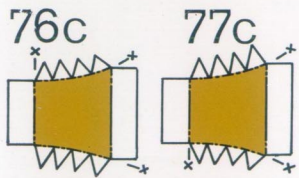
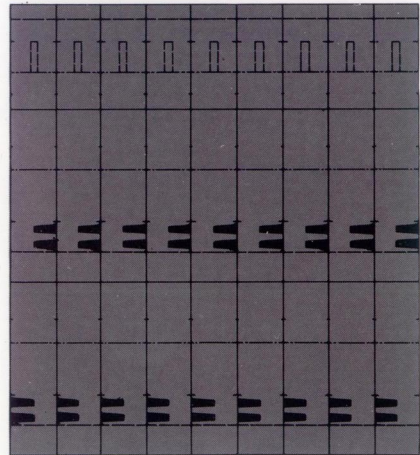
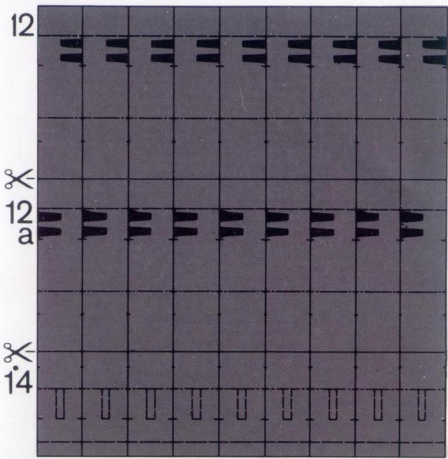

31a_30b

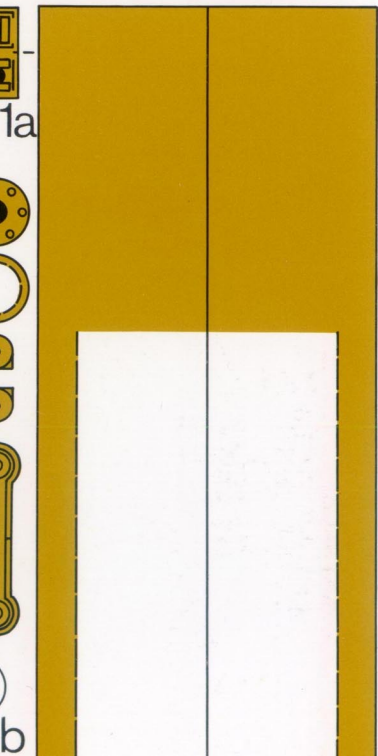
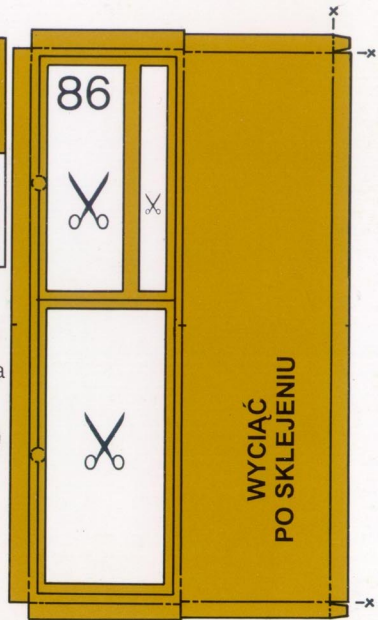
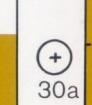
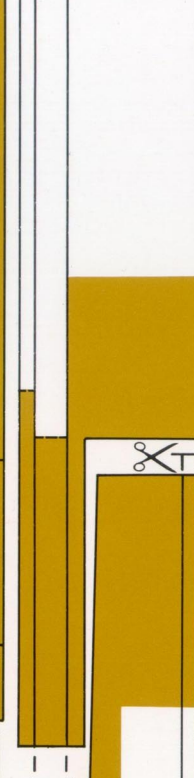

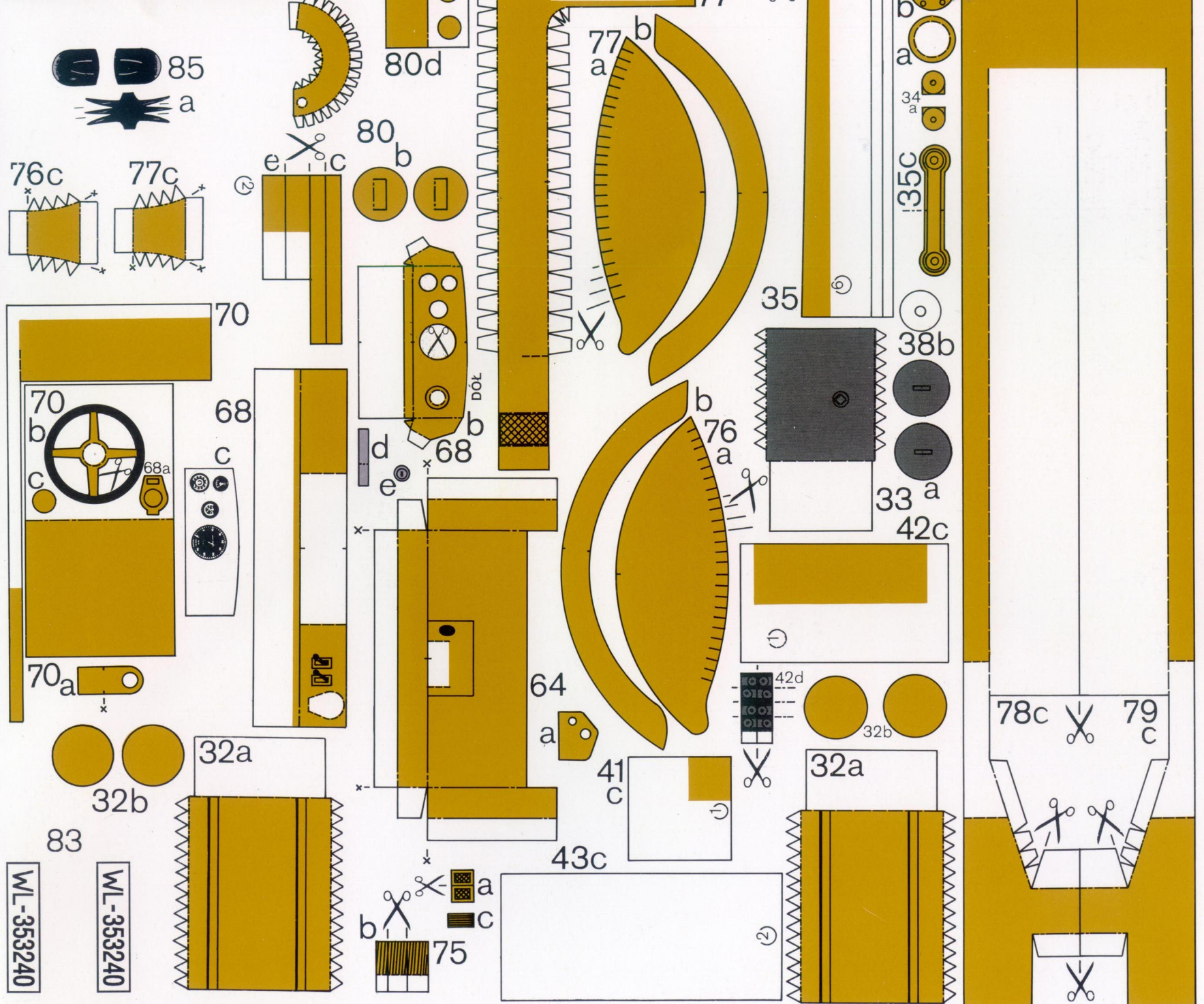

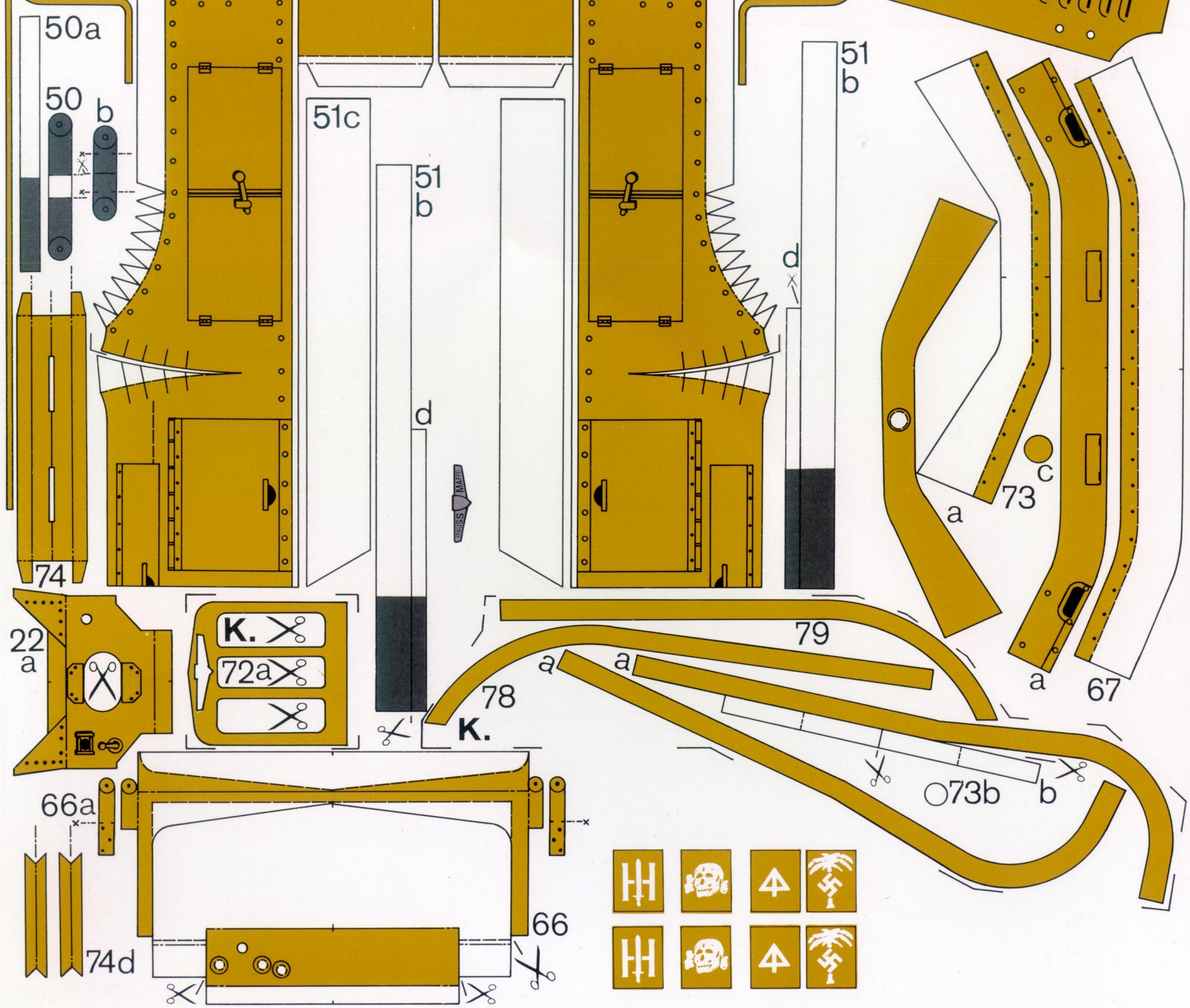

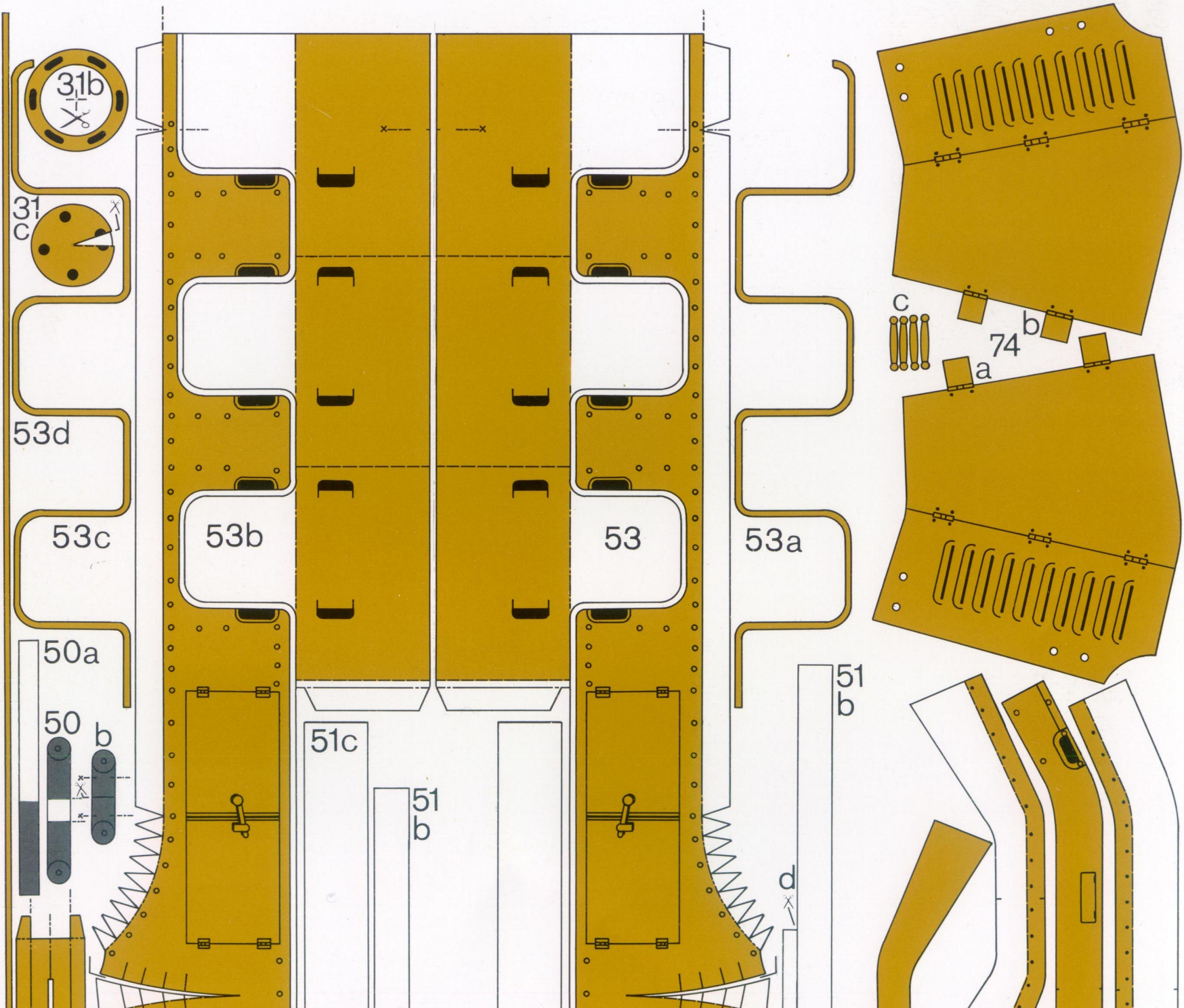

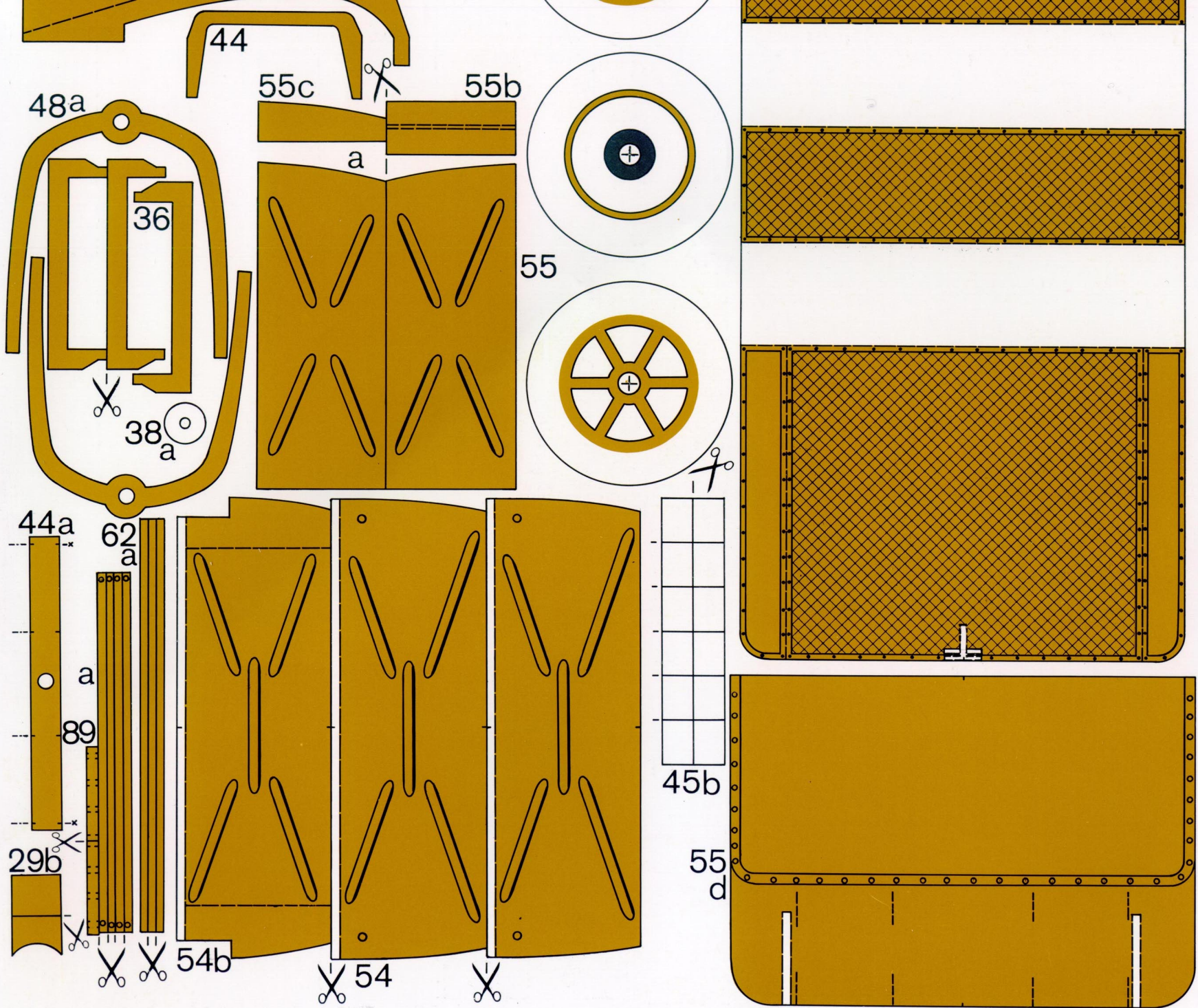

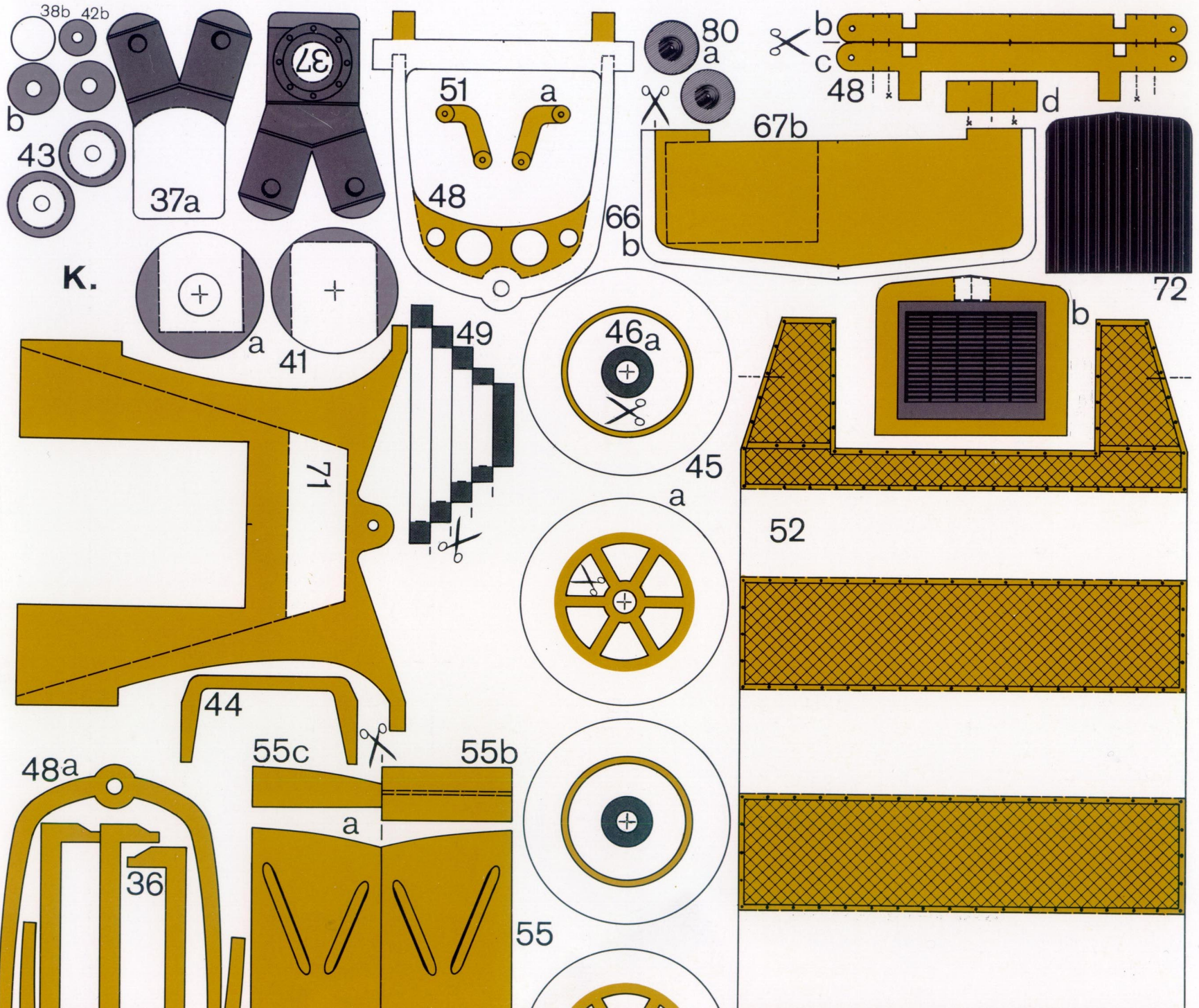

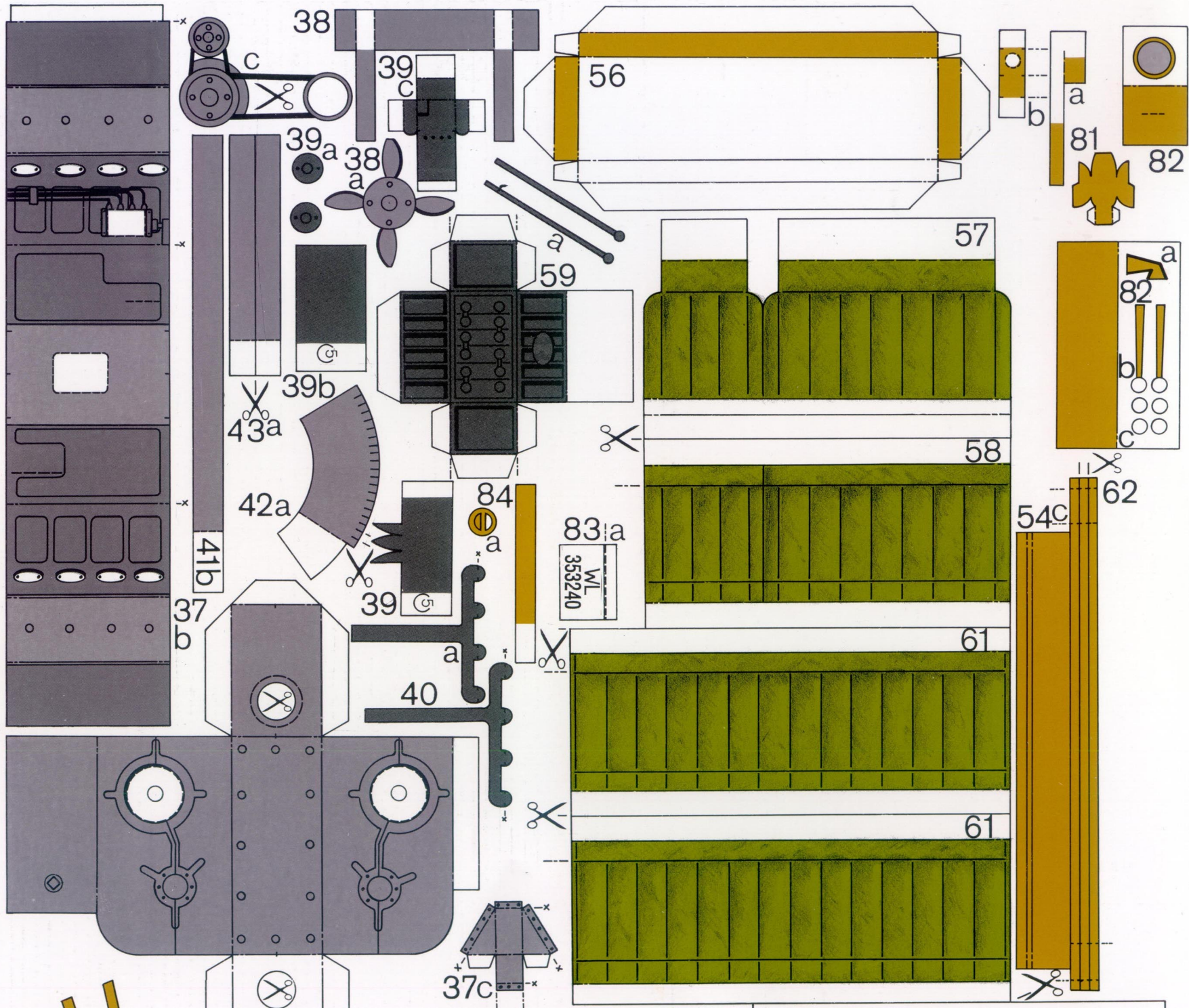

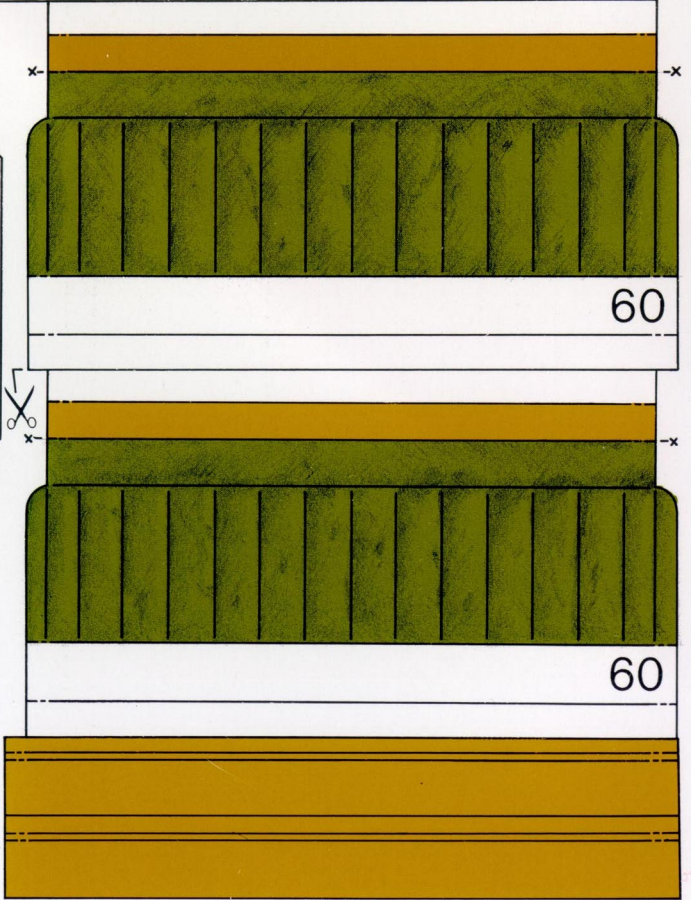
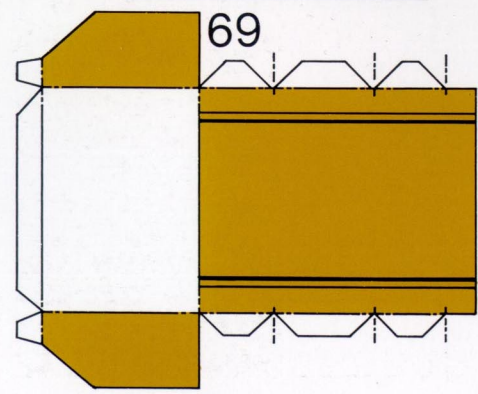
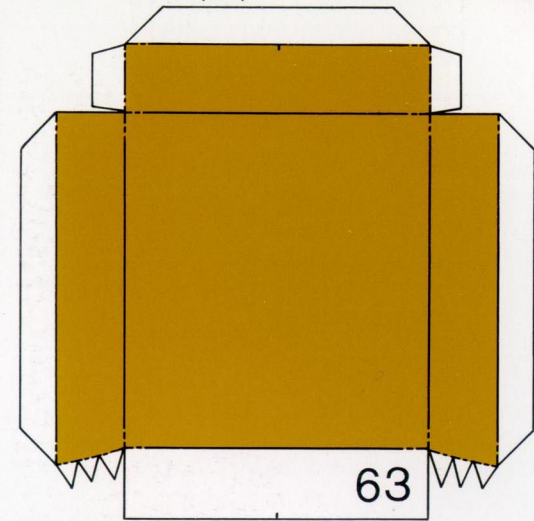
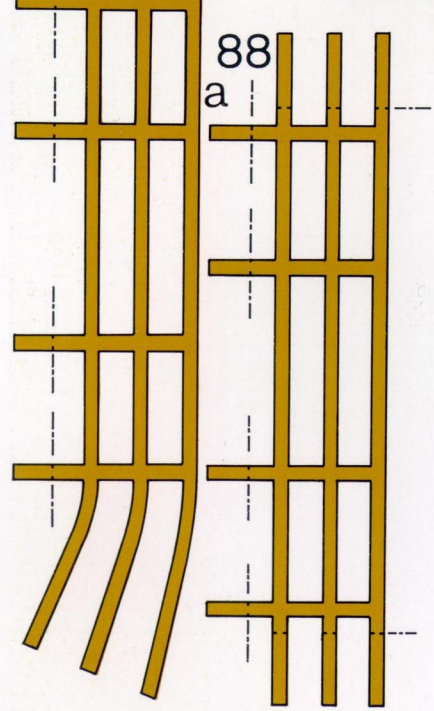
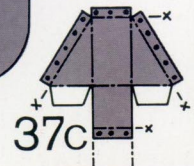
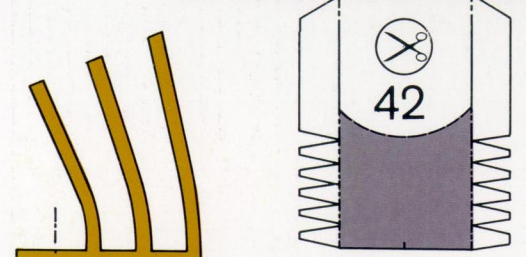
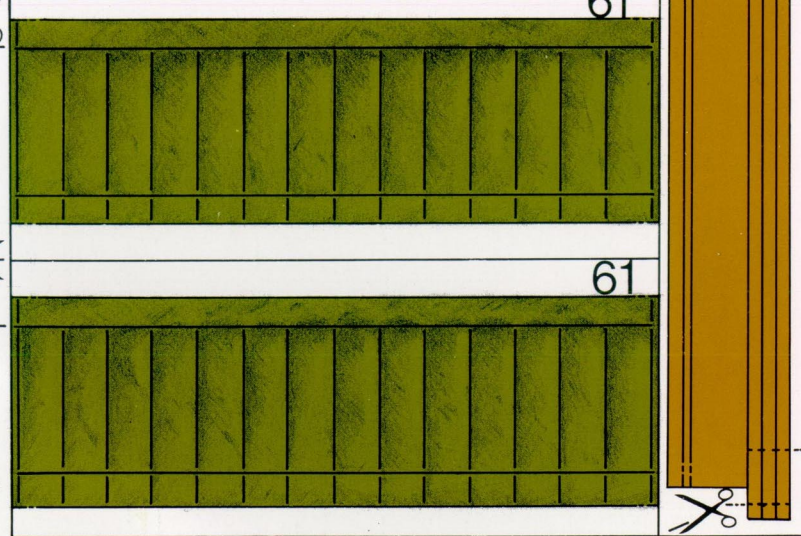
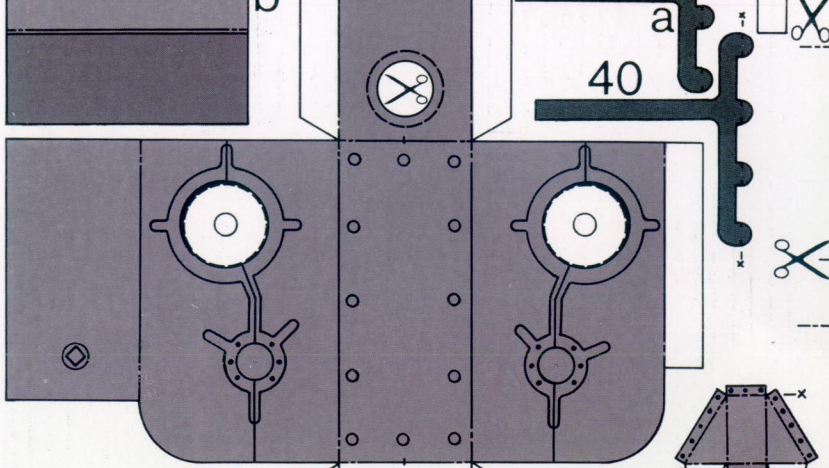

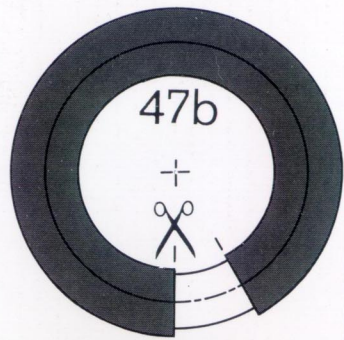

47b

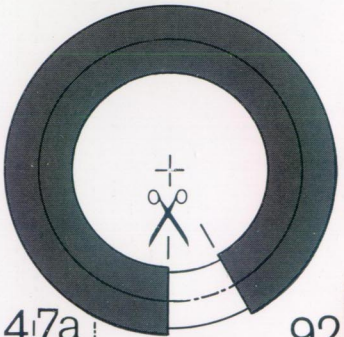
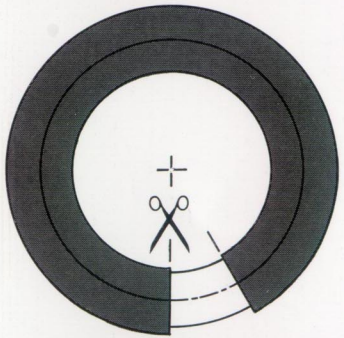
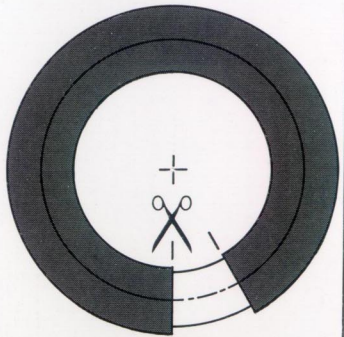

47a

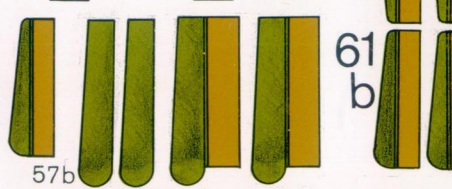
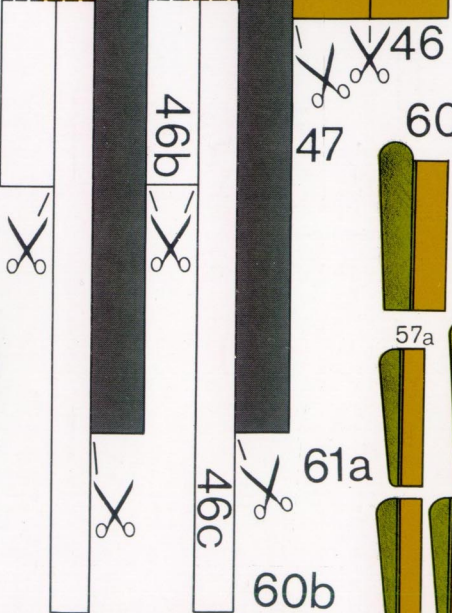
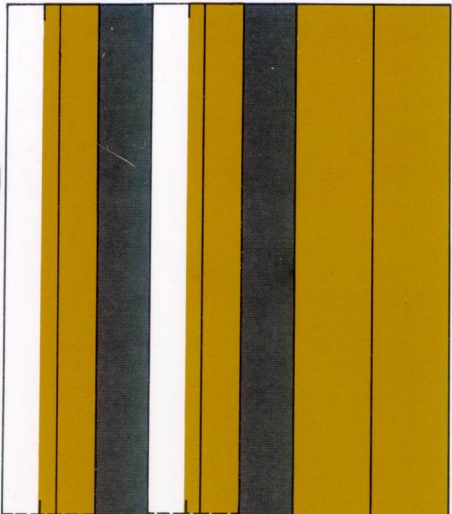

46b

46

47

60a

57a

61a

60b

61b

57b

92
C

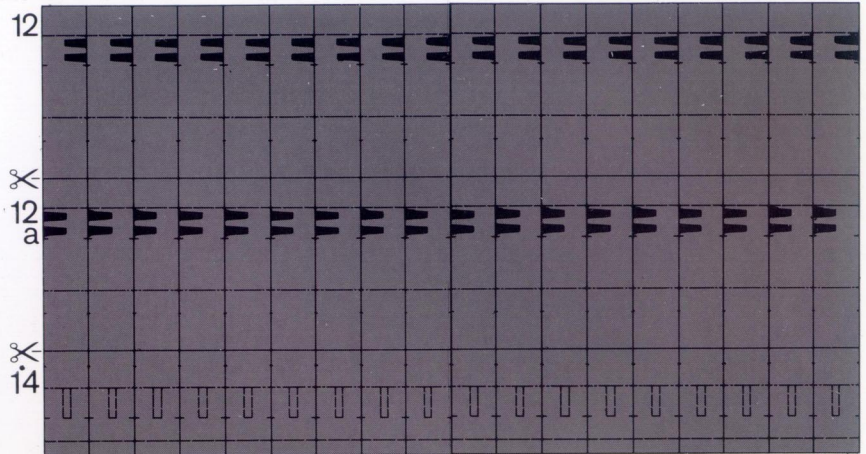

12
12
a

14

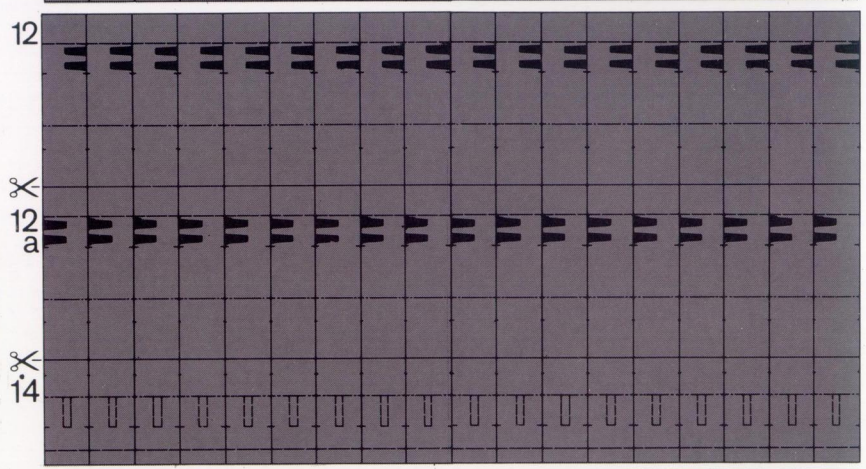

12

12
a

14

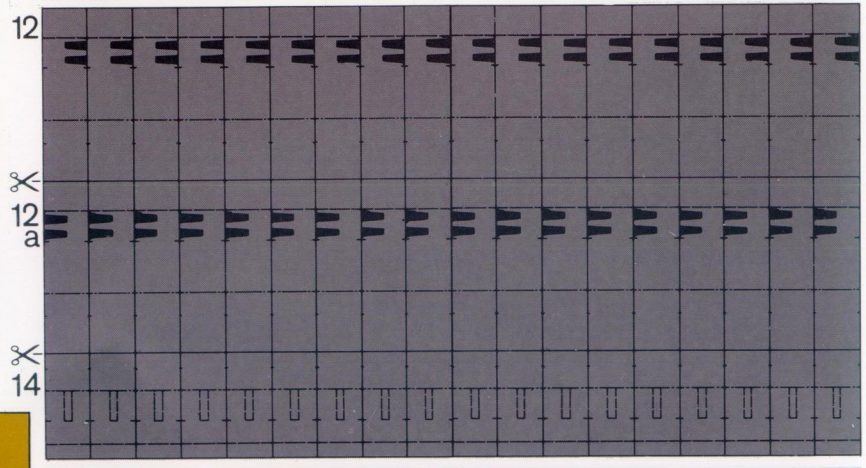

12

12
a

14



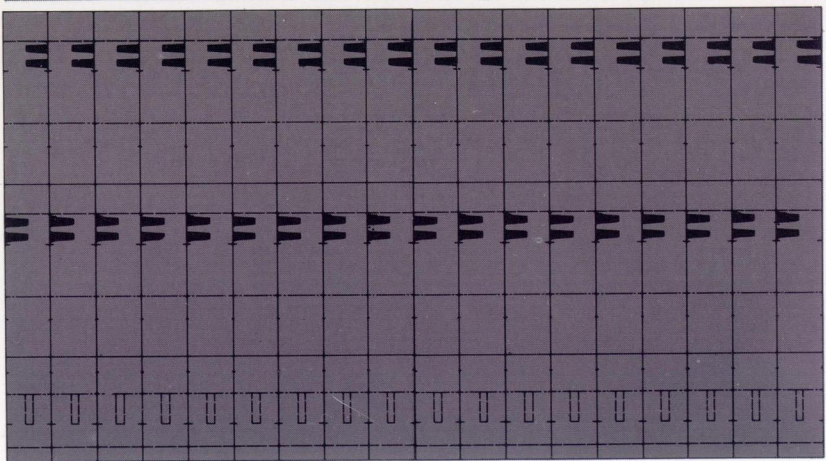
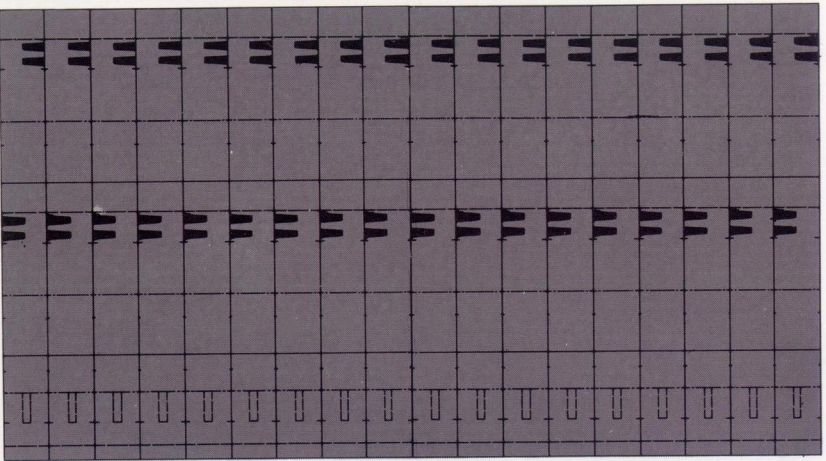
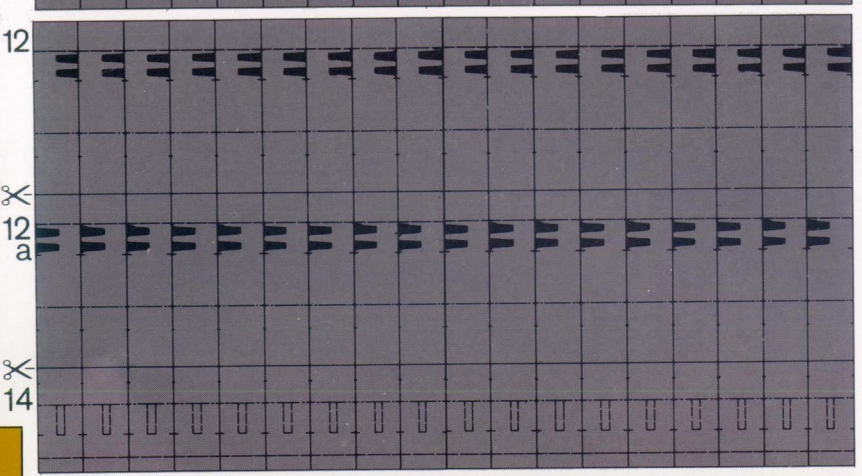
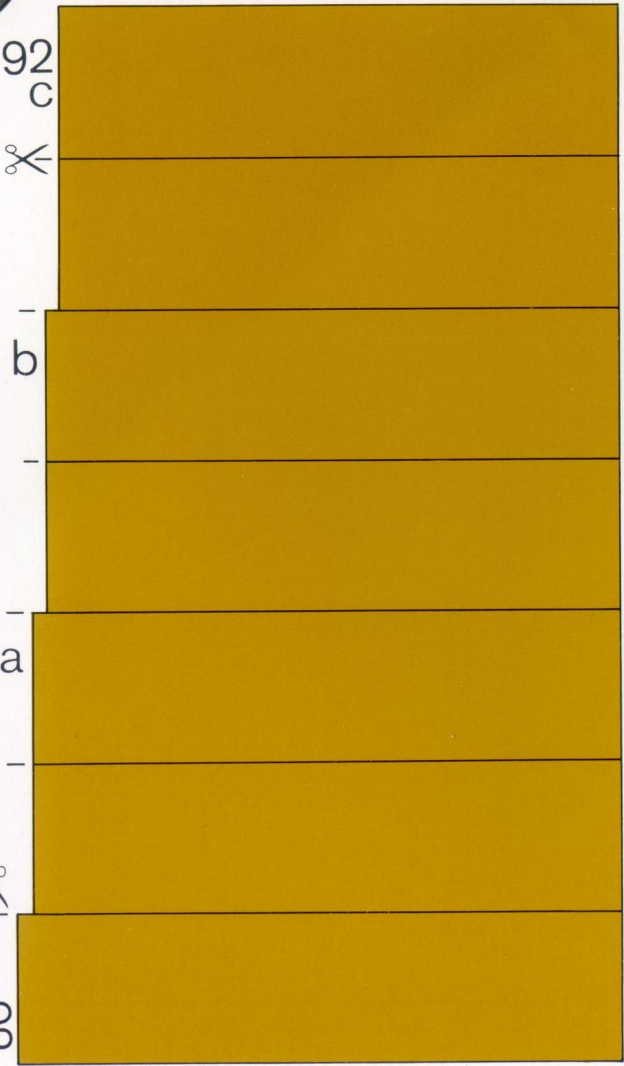
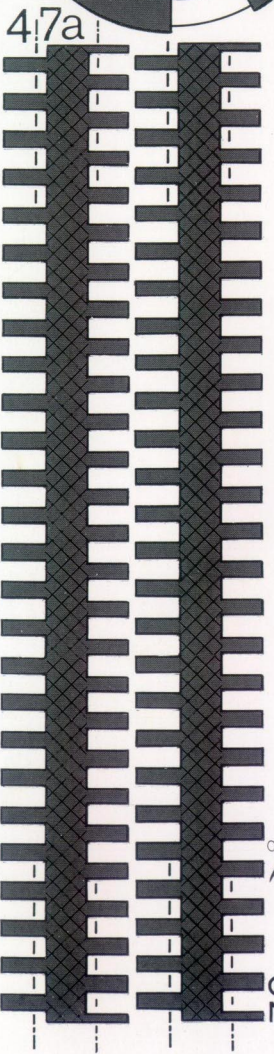
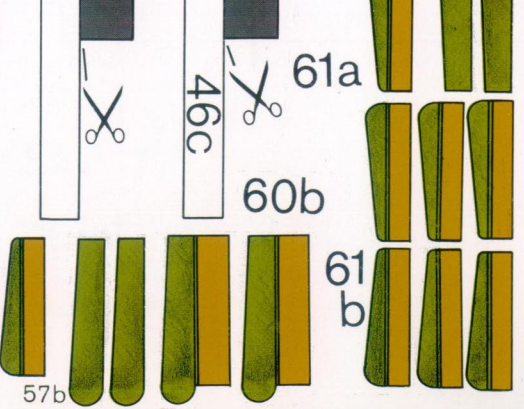
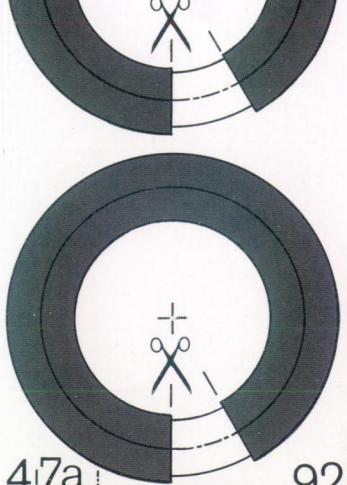

23 a

④



1

②

②



1

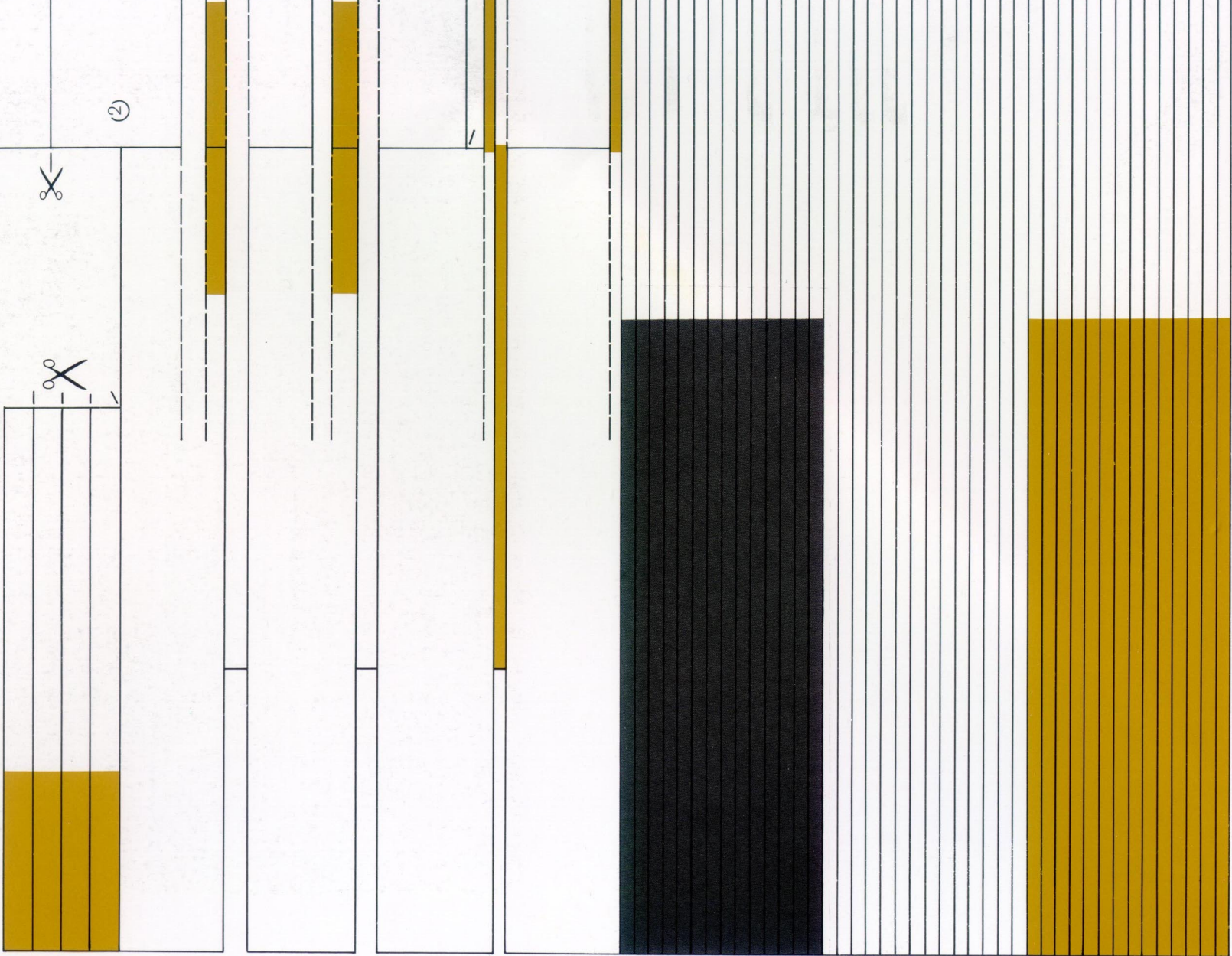

27a

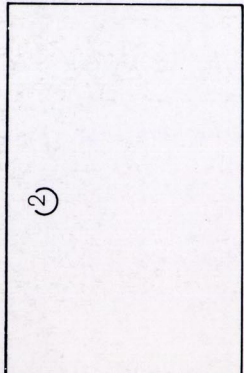

24
b

(2,5)

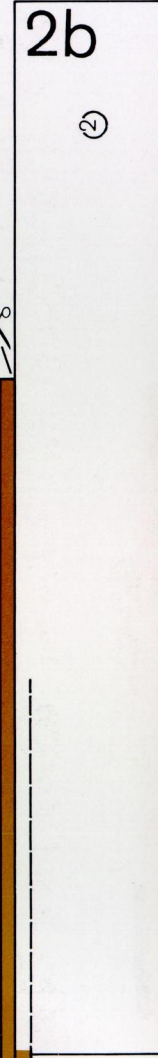
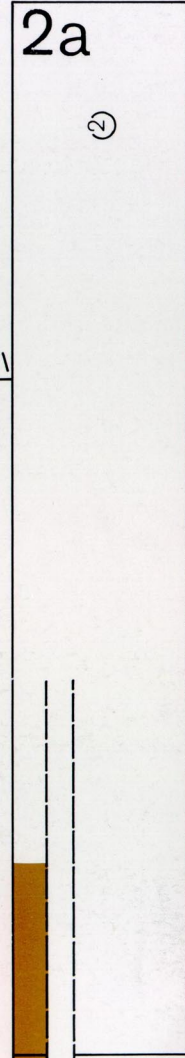
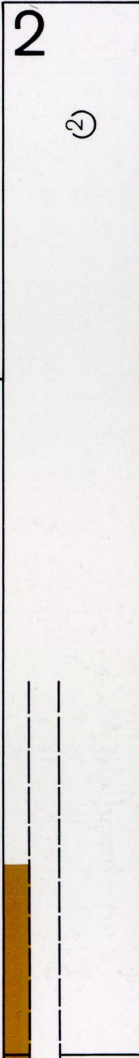
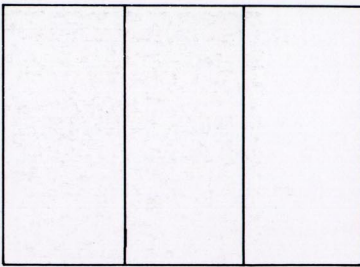

25c

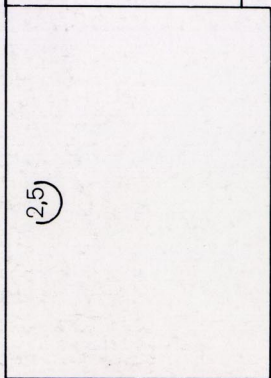

24c d

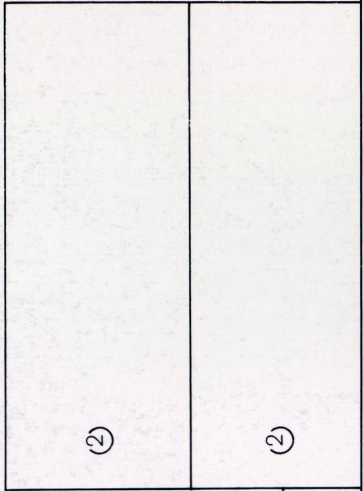

3b

3a

3

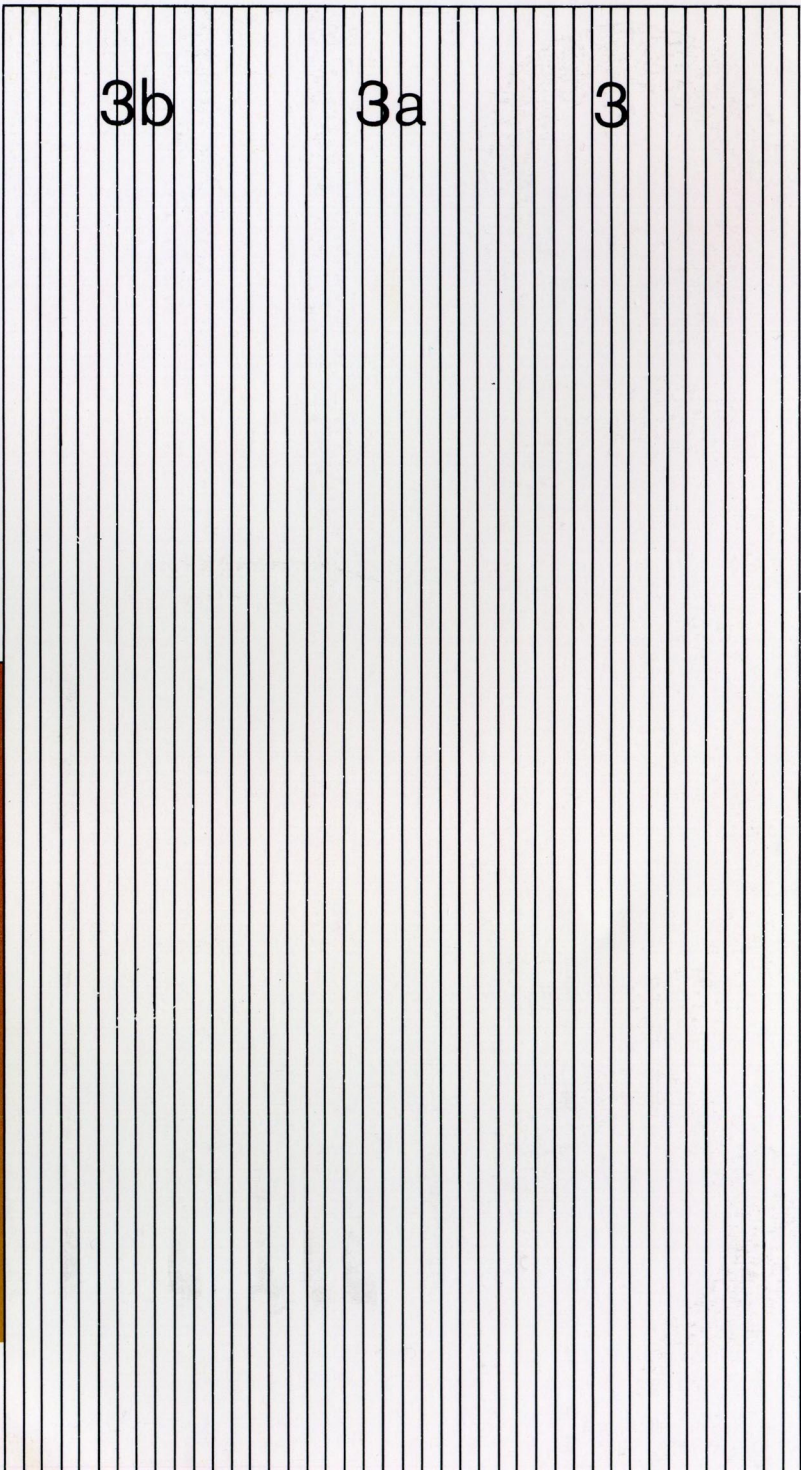

27a

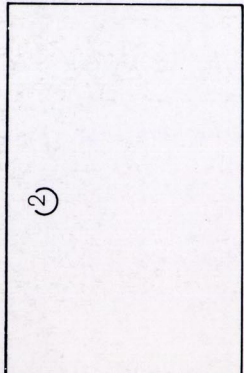

24
b

(2,5)

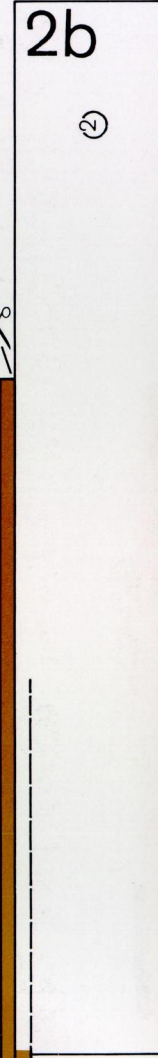
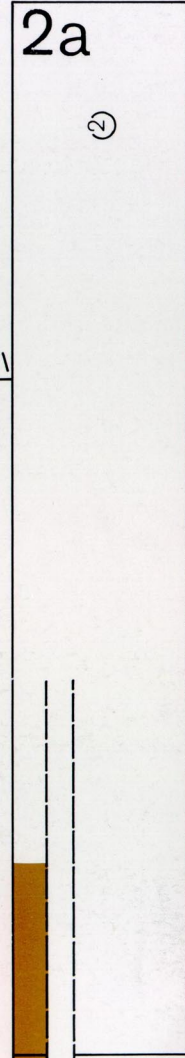
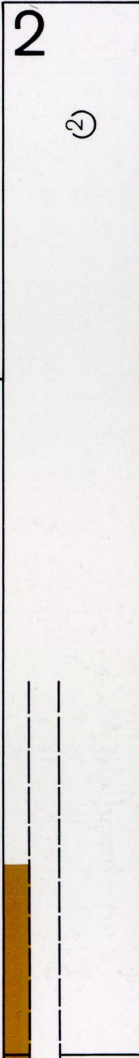
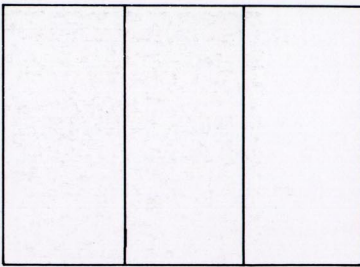

25c

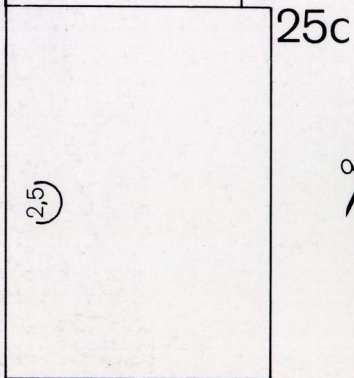

24c d

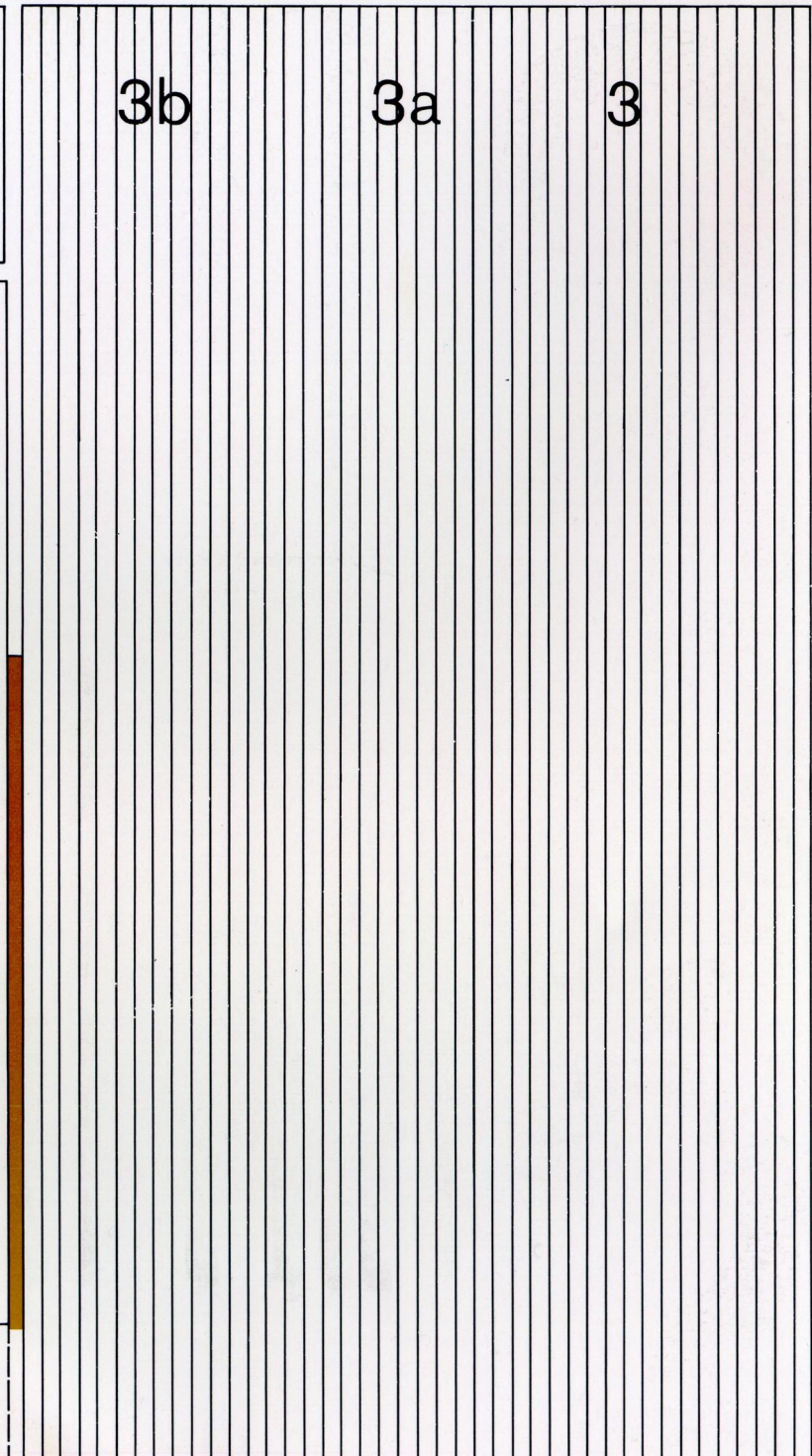
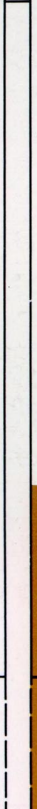
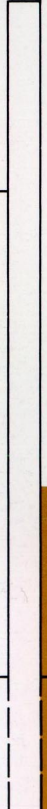
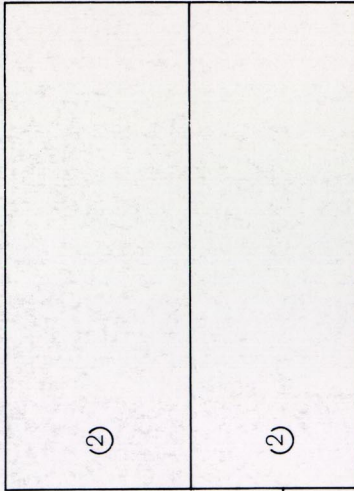

3b

3a

3