

БУМАЖНОЕ МОДЕЛИРОВАНИЕ

СЕРИЯ: ГРАЖДАНСКАЯ ТЕХНИКА

АВТОМОБИЛЬ

ГАЗ-51

СССР, 1947 г.



масштаб **1:25**

степень сложности

1

2

3



PAMA

THE FRAME

DER RAHMEN

RAMA

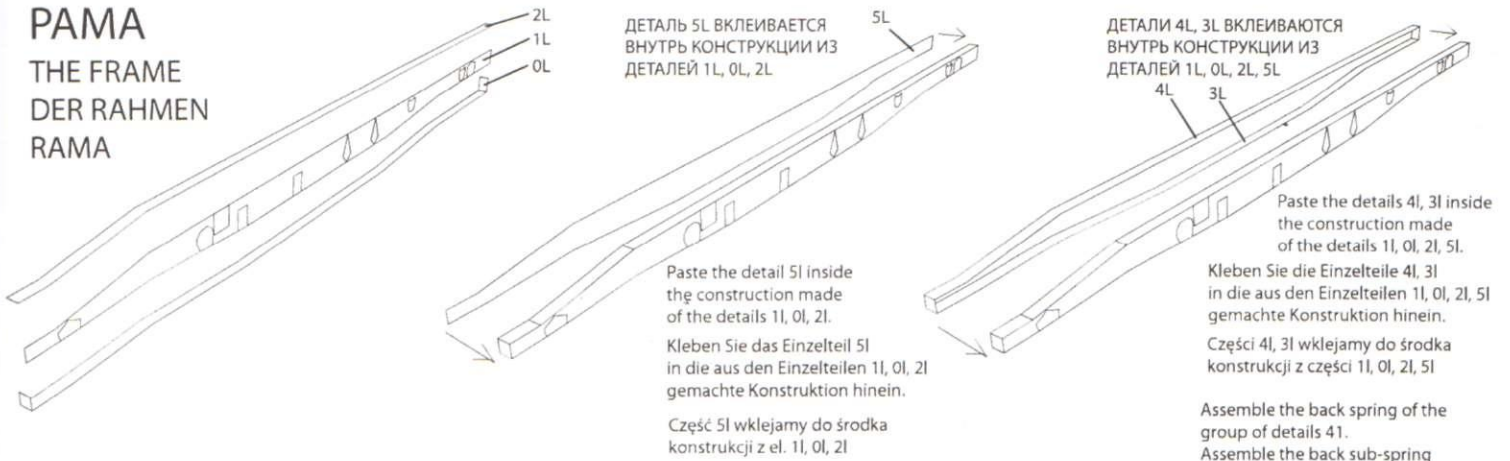

ПЕРЕДНЯЯ РЕССОРА СОБИРАЕТСЯ ИЗ ГРУППЫ ДЕТАЛЕЙ 42, СКЛЕЕННЫХ ПООЧЕРЕДНО

Assemble the front spring of the group of details 42, pasted alternately.

Sammeln Sie die Vorderfeder aus der Gruppe der abwechselnd geklebten Einzelteile 42.

Przedni resor składa się z elementów o oznaczeniu 42, sklejonych po kolei

ЗАДНЯЯ РЕССОРА СОБИРАЕТСЯ ИЗ ГРУППЫ ДЕТАЛЕЙ 41. ЗАДНЯЯ ПОДРЕССОРА СОБИРАЕТСЯ ИЗ ДЕТАЛЕЙ ГРУППЫ 43

Tylny resor montujemy z grupy części o oznaczeniu 41. Tylny podresor składa się z elementów o oznaczeniu 43

Assemble the back spring of the group of details 41.

Assemble the back sub-spring of the group of details 43.

Sammeln Sie die Hinterfeder aus der Gruppe der Einzelteile 41.

Sammeln Sie die Hintersubfeder aus der Gruppe der Einzelteile 43.

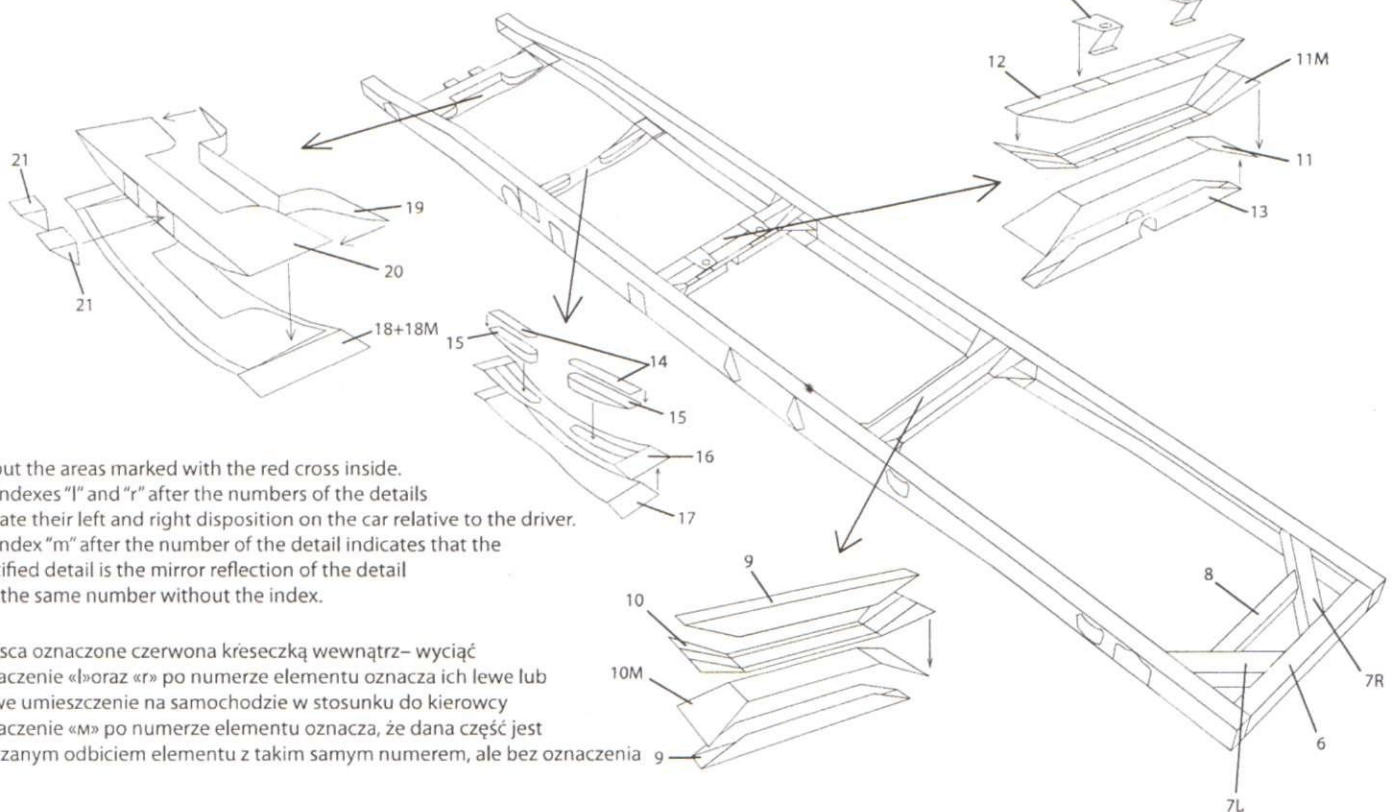
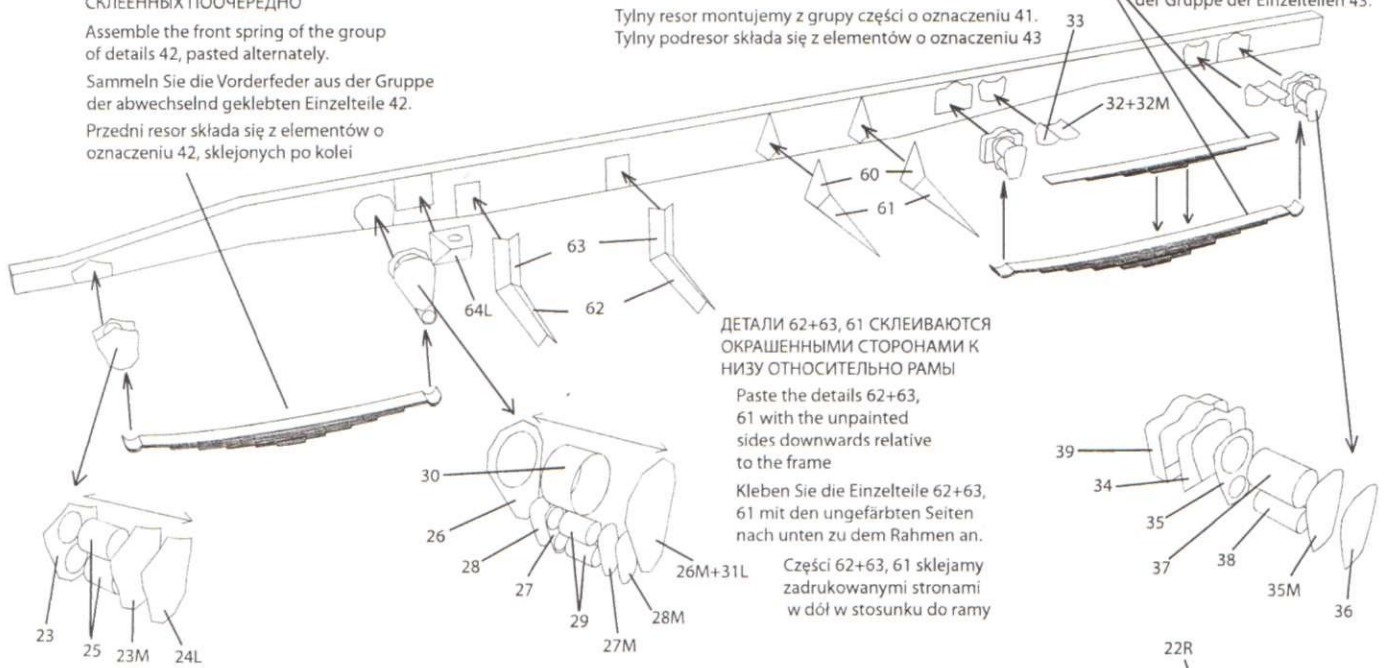

КУЗОВ

The body
Der Wagenkasten
Nadwozie

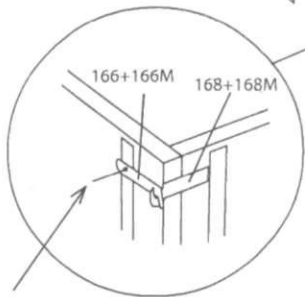
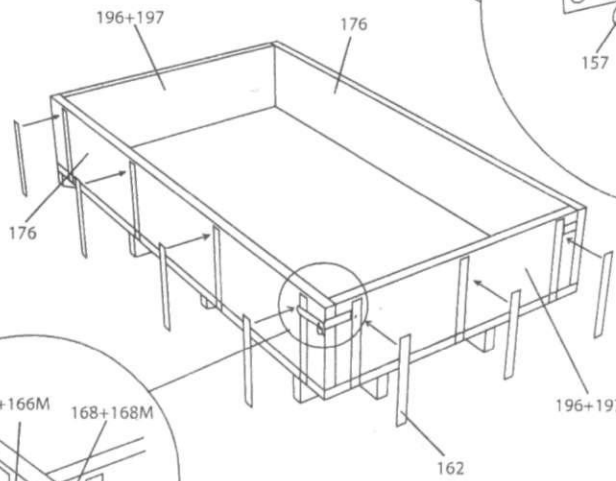
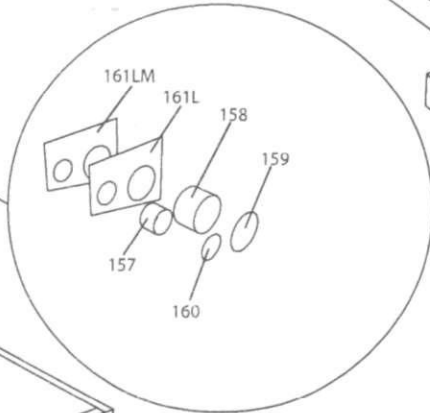
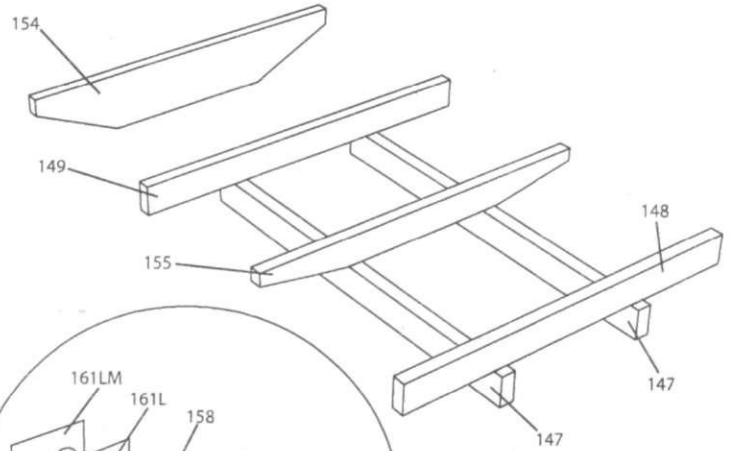
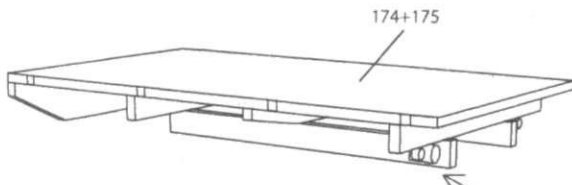

ПРОВОЛОКА
The wire
Der Draht
Drut

КАБИНА

The cab
Das Fahrerhaus
Kabina

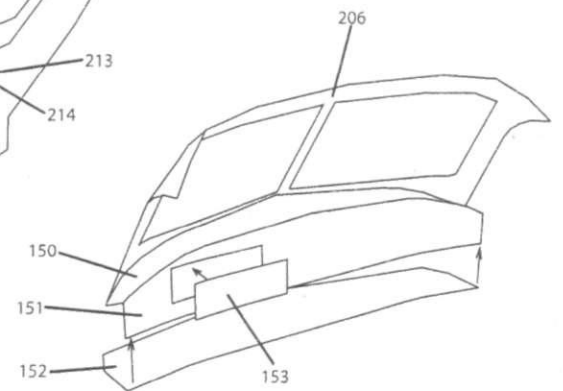
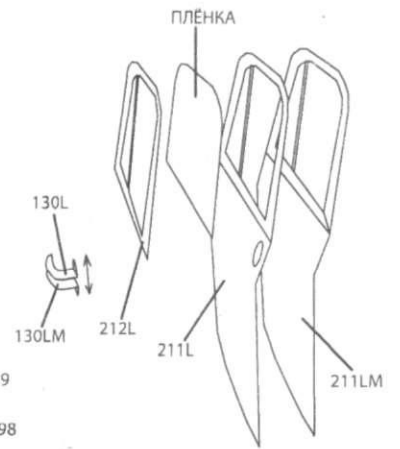
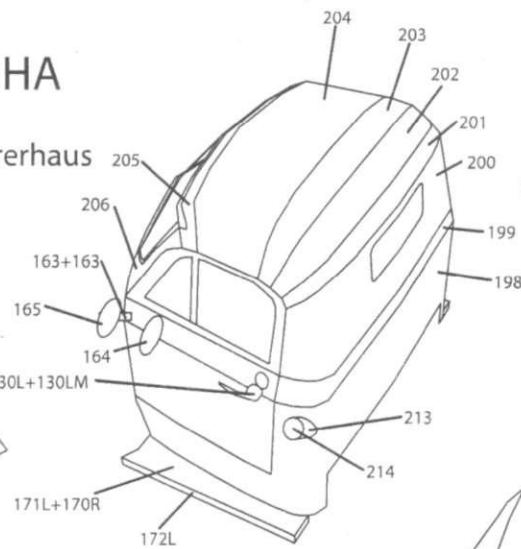
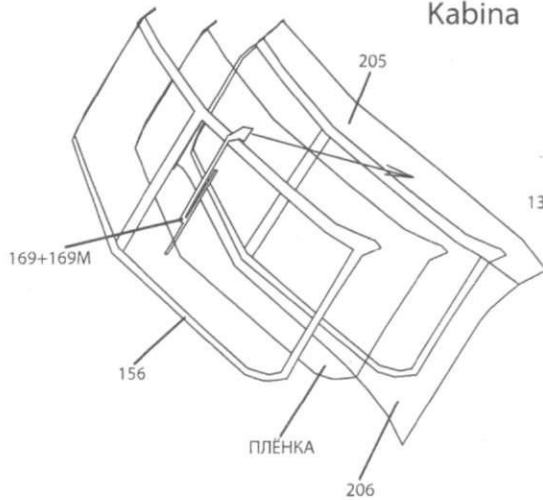

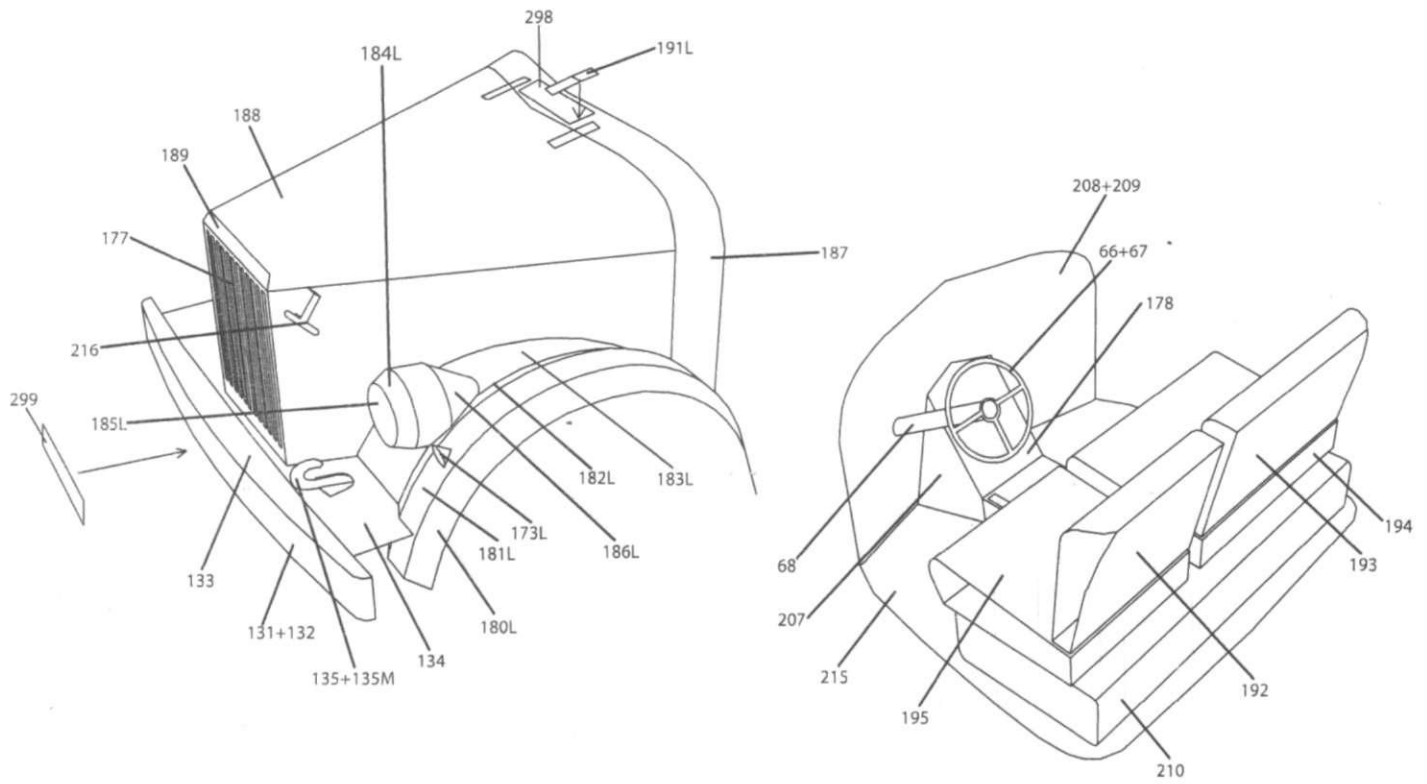

БЕНЗОБАК

The petrol tank
Der Benzintank
Zbiornik paliwa

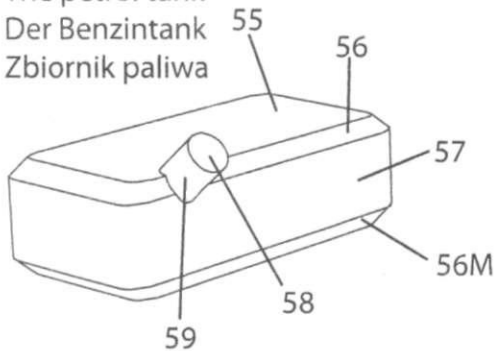

БЕНЗОБАК ПОСЛЕ СКЛЕИВАНИЯ ПОМЕЩАЕТСЯ НА ДЕТАЛИ РАМЫ ПОД НОМЕРАМИ 61

ЗАПАСНОЕ КОЛЕСО ПОМЕЩАЕТСЯ НА ДЕТАЛЬ РАМЫ ПОД НОМЕРОМ 65R. ЭТА ДЕТАЛЬ КЛЕИТСЯ ПО ПРАВОЙ (ОТ ВОДИТЕЛЯ) СТОРОНЕ РАМЫ

After the petrol tank is pasted, place it on the details of the frame under no. 61

Place the spare wheel on the detail of the frame under no. 65r. This detail should be glued on the right (relative to the driver) side of the frame

Setzen Sie den Benzintank nach dem Aufkleben auf die Einzelteile des Rahmens unter Nummer 61.

Setzen Sie das Sparrand auf das Einzelteil des Rahmens unter Nummer 65r. Kleben Sie dieses Einzelteil auf die rechte Seite (zu dem Fahrer) des Rahmens

Zbiornik paliwa po sklejeniu umieszczamy na ramie pod numerem 61

Kolo zapasowe umieszczamy na ramie pod numerem 65r. Ten element powinien znaleźć się po prawej (od kierowcy) stronie ramy

ЗАДНЕЕ КОЛЕСО

The back wheel
Das Hinterrad
Tylne koło

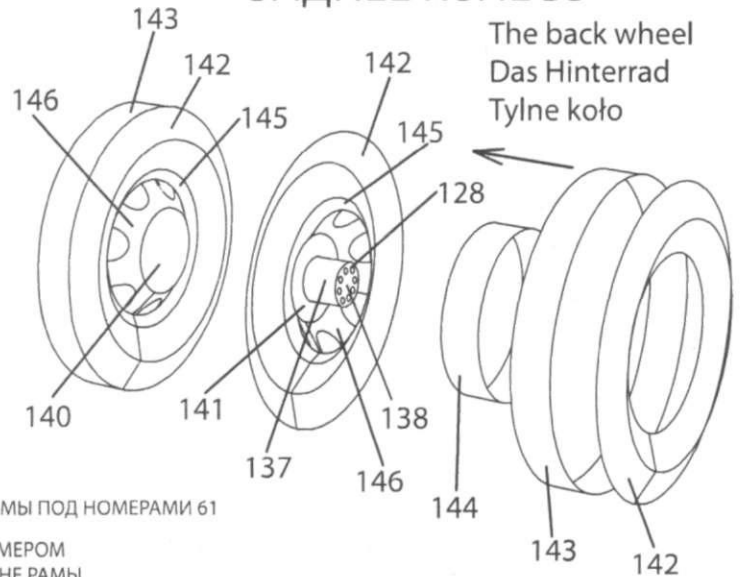

ЗАДНИЙ МОСТ

The back bridge
Die Hinterbrücke
Tylny most

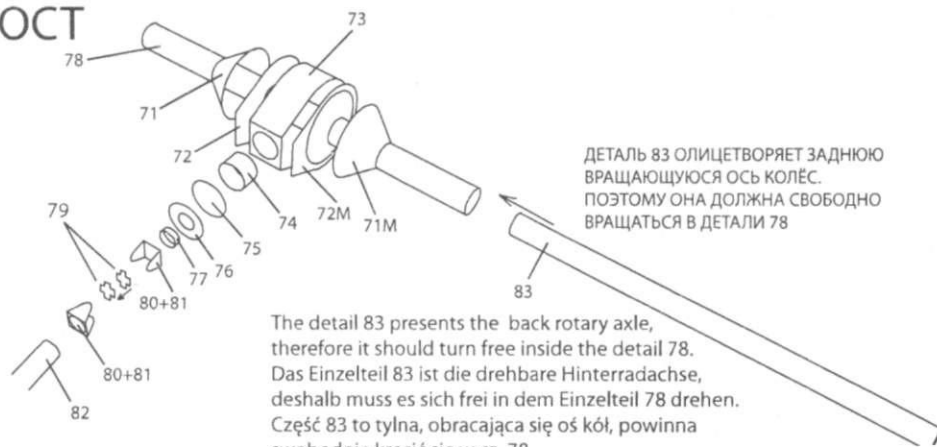

ДЕТАЛЬ 83 ОЛИЦЕТВОРЯЕТ ЗАДНИЮ ВРАЩАЮЩУЮСЯ ОСЬ КОЛЁС. ПОЭТОМУ ОНА ДОЛЖНА СВОБОДНО ВРАЩАТЬСЯ В ДЕТАЛИ 78

The detail 83 presents the back rotary axle, therefore it should turn free inside the detail 78.
Das Einzelteil 83 ist die drehbare Hinterradachse, deshalb muss es sich frei in dem Einzelteil 78 drehen.

Część 83 to tylna, obracająca się oś kół, powinna

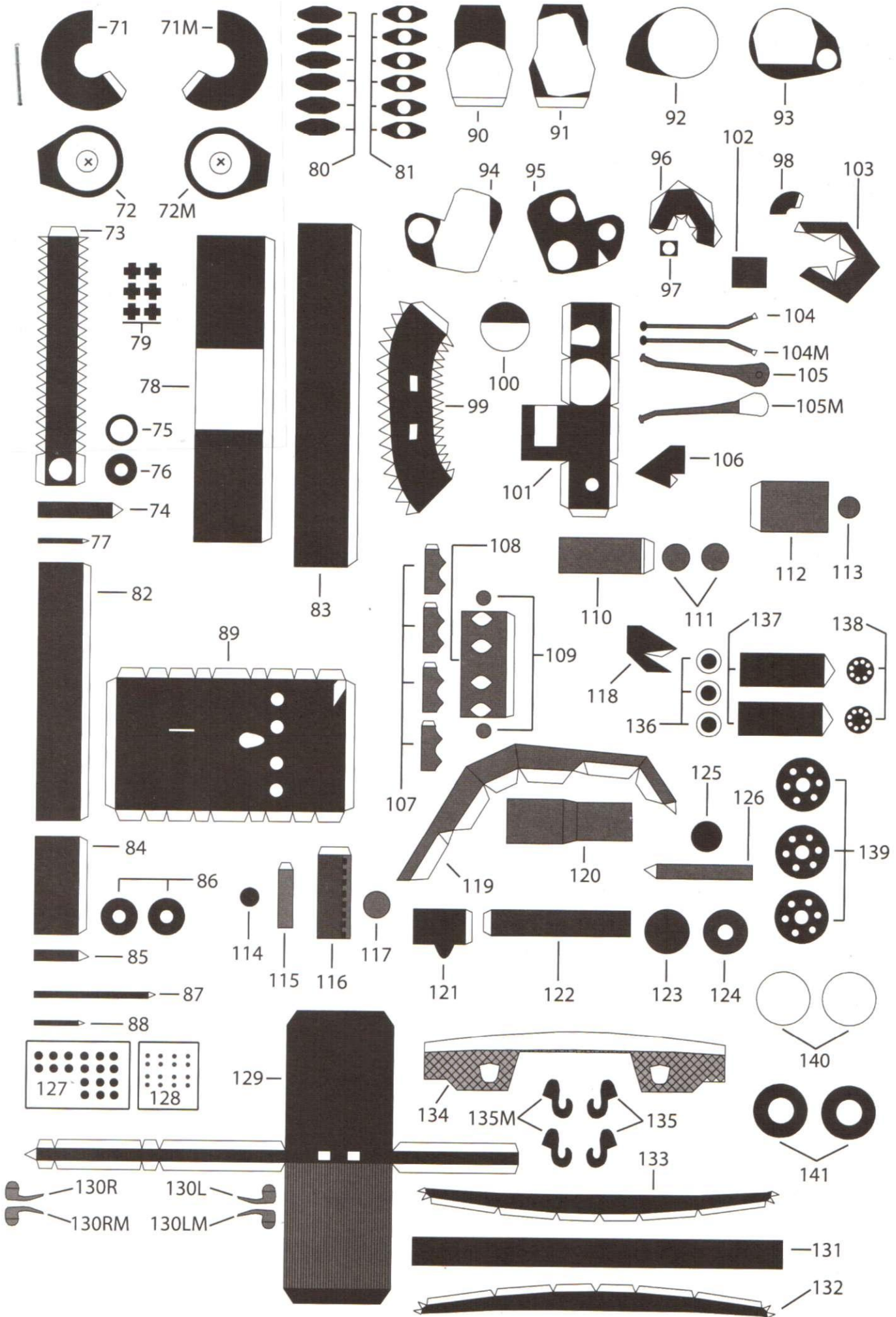

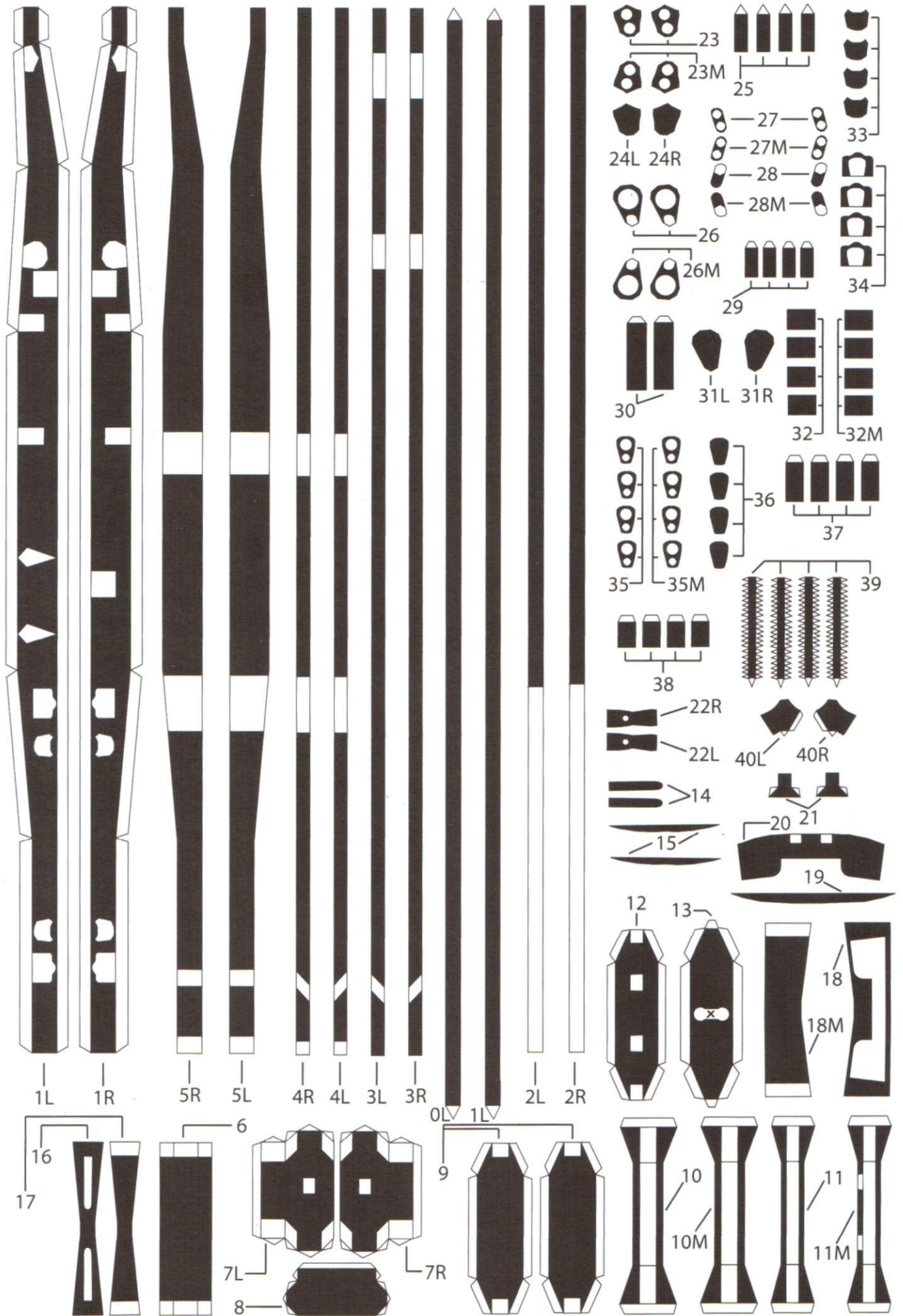

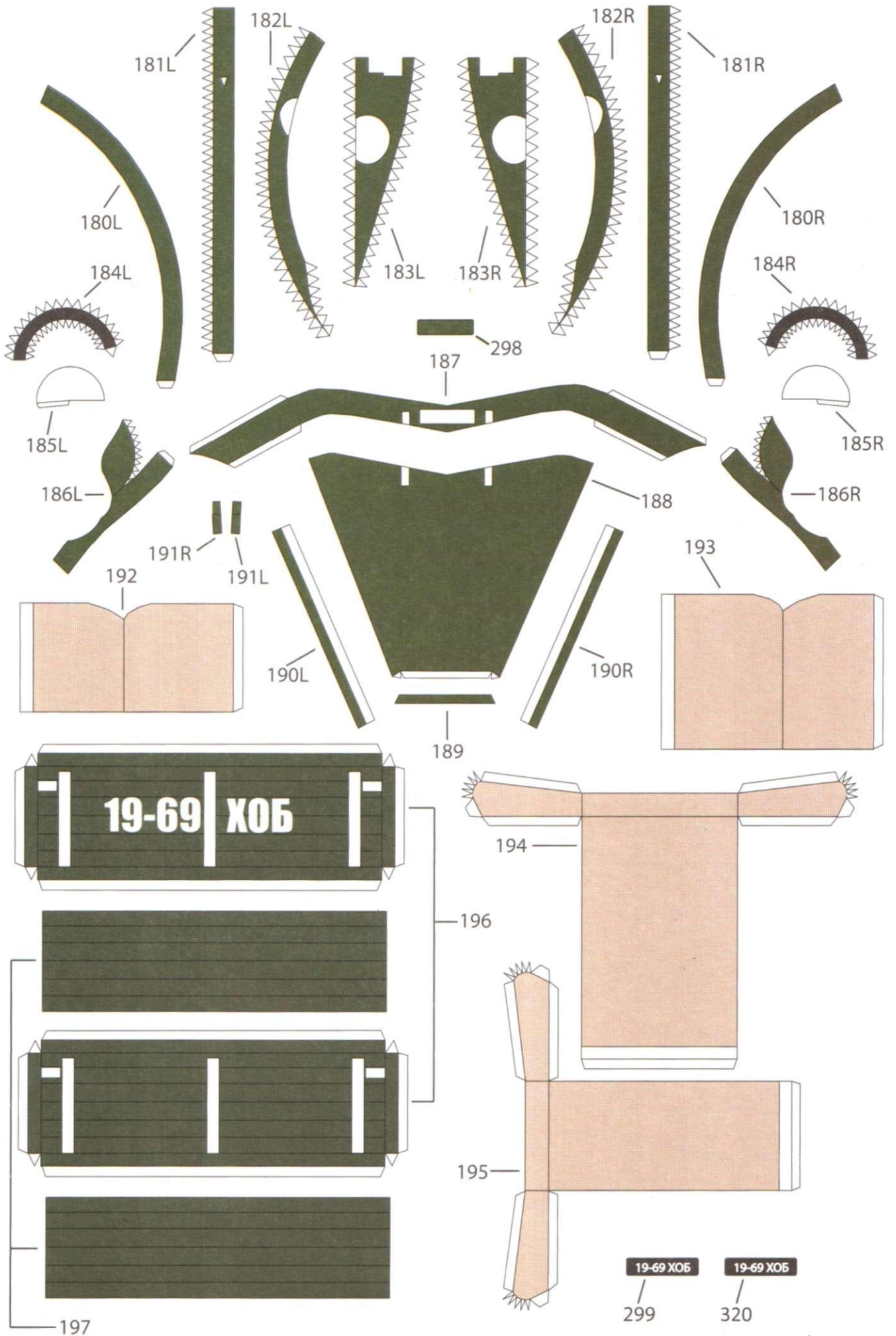

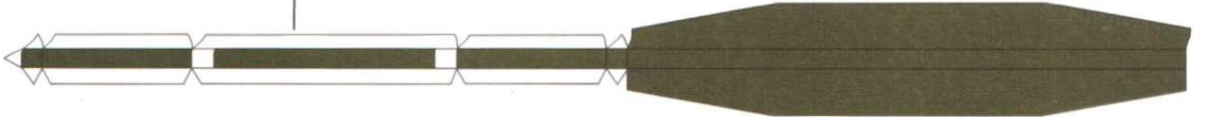
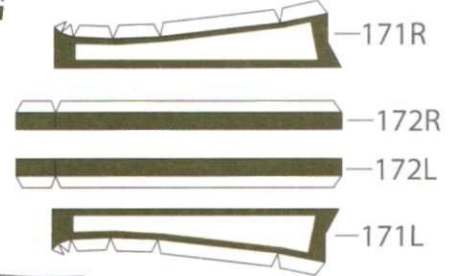
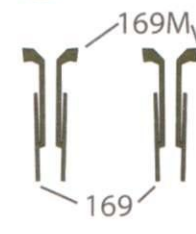
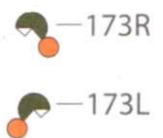
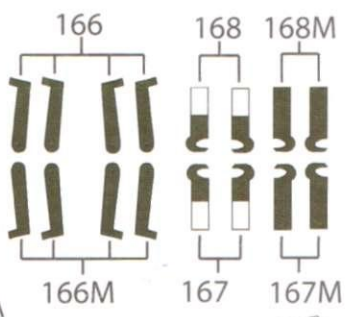
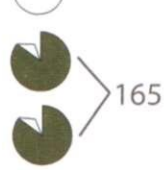
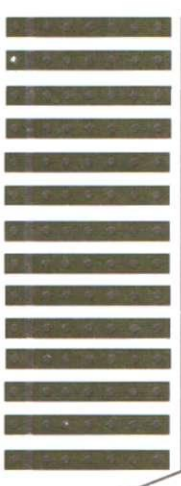
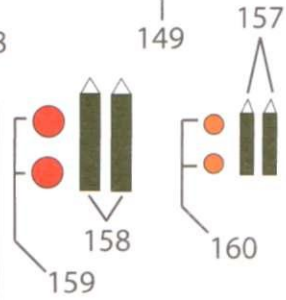
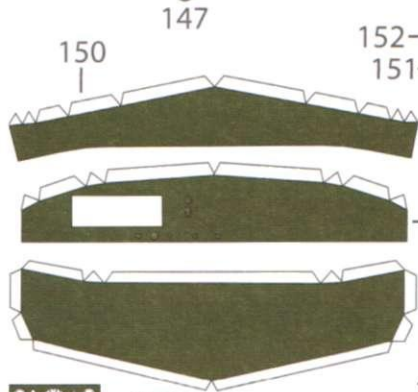
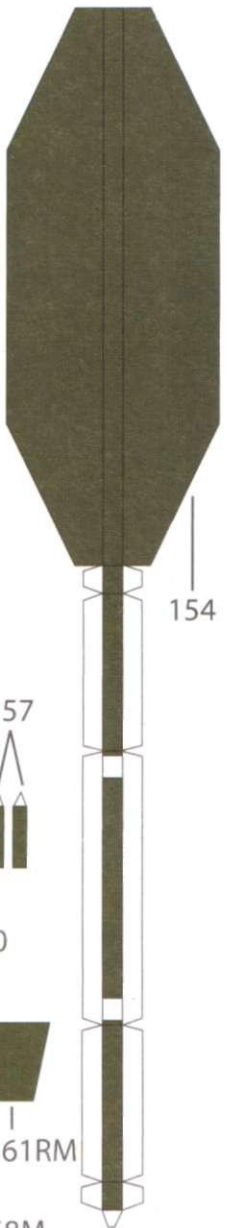
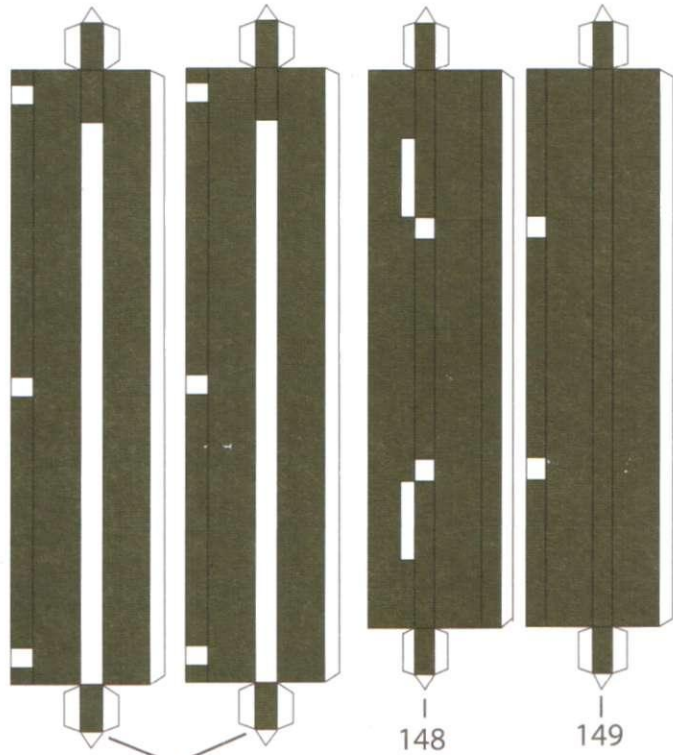
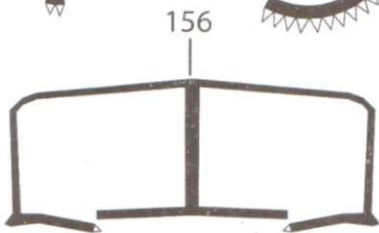
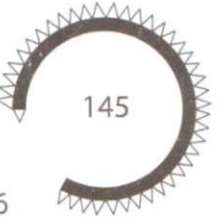
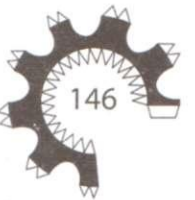
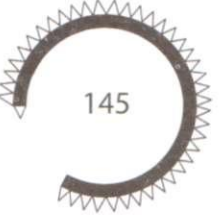
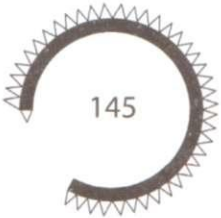
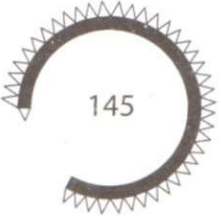
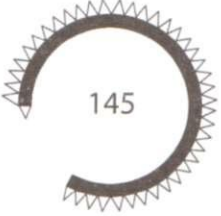
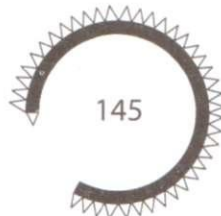

174

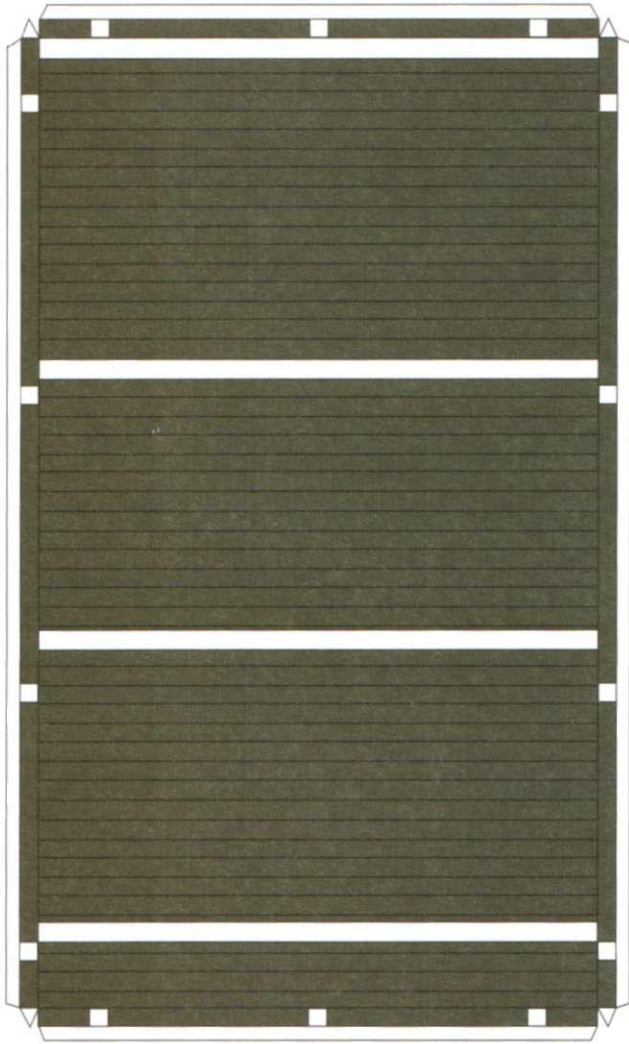

175

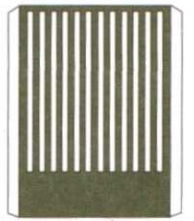
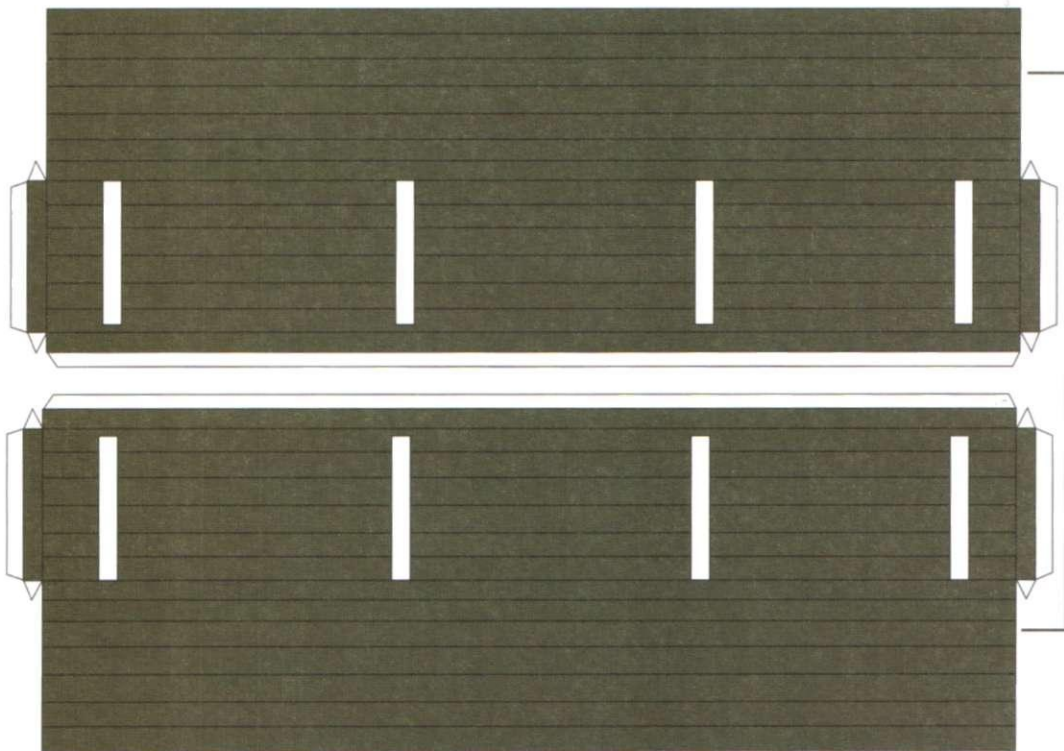

177

176

178

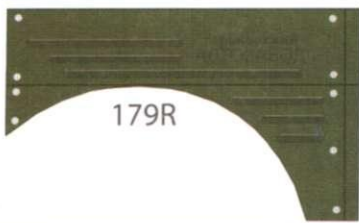

179R

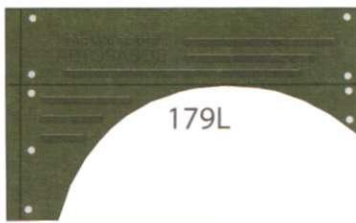

179L

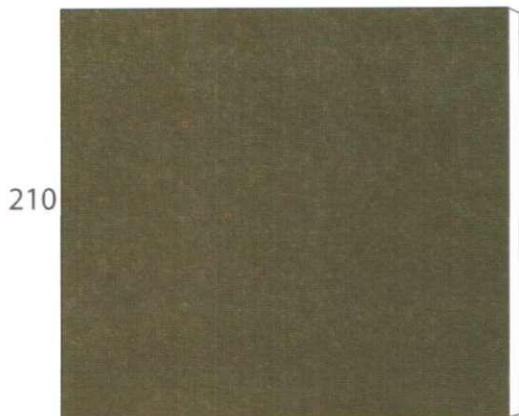
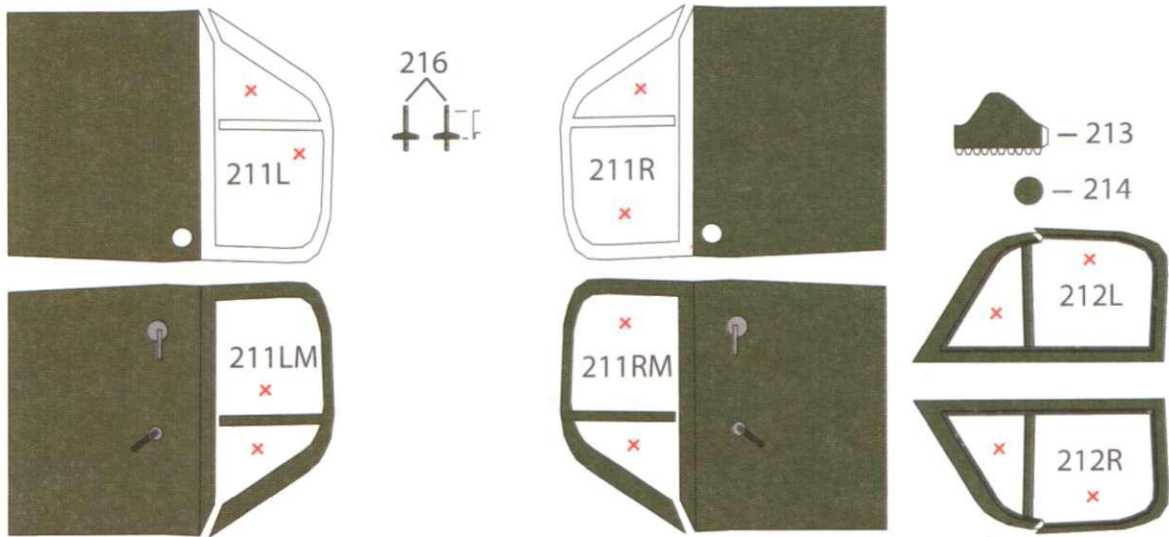
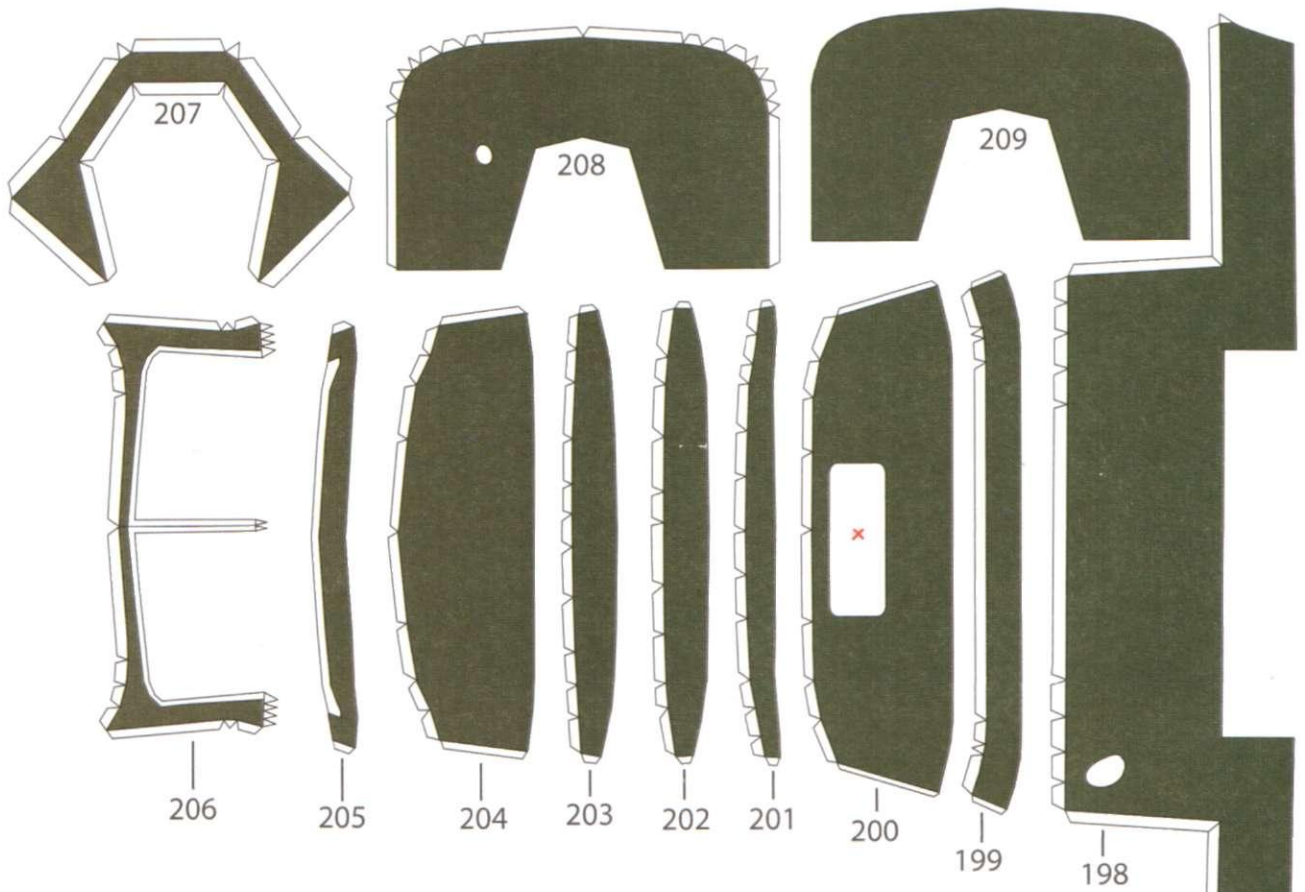

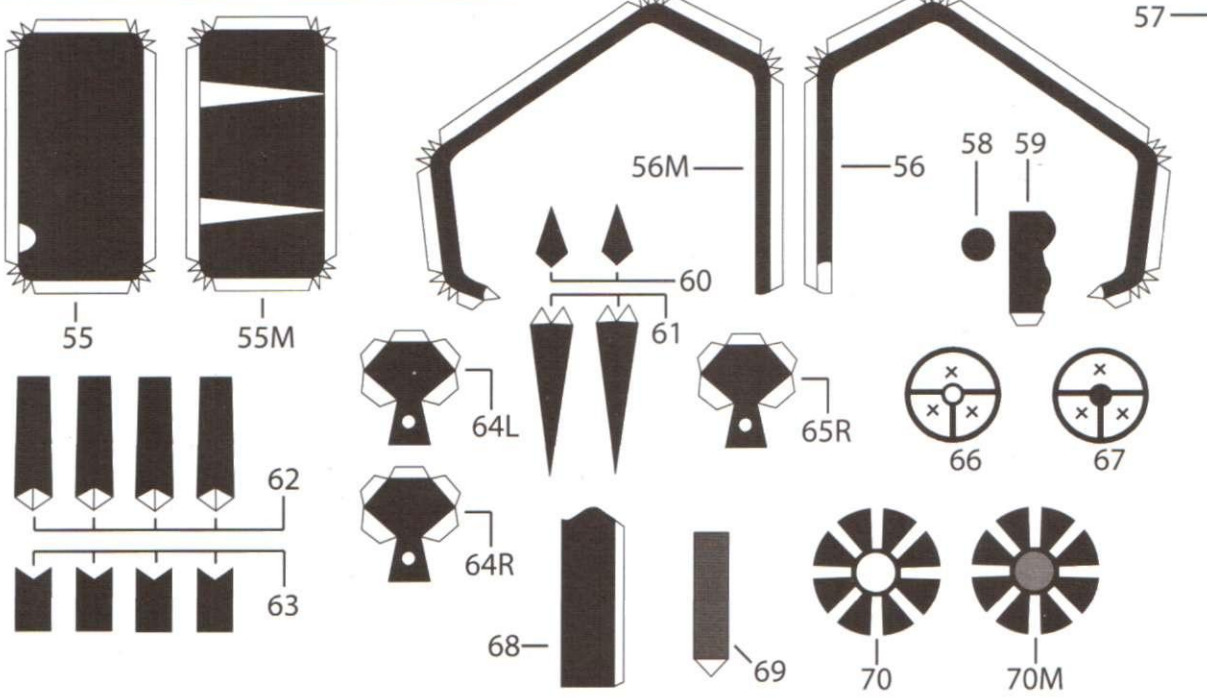
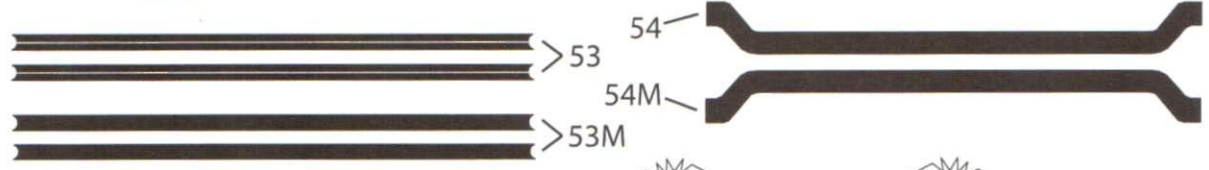
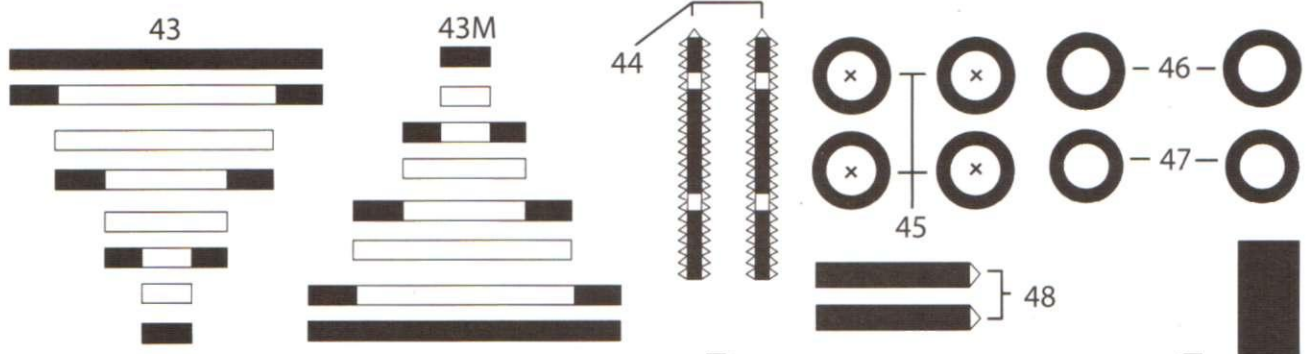
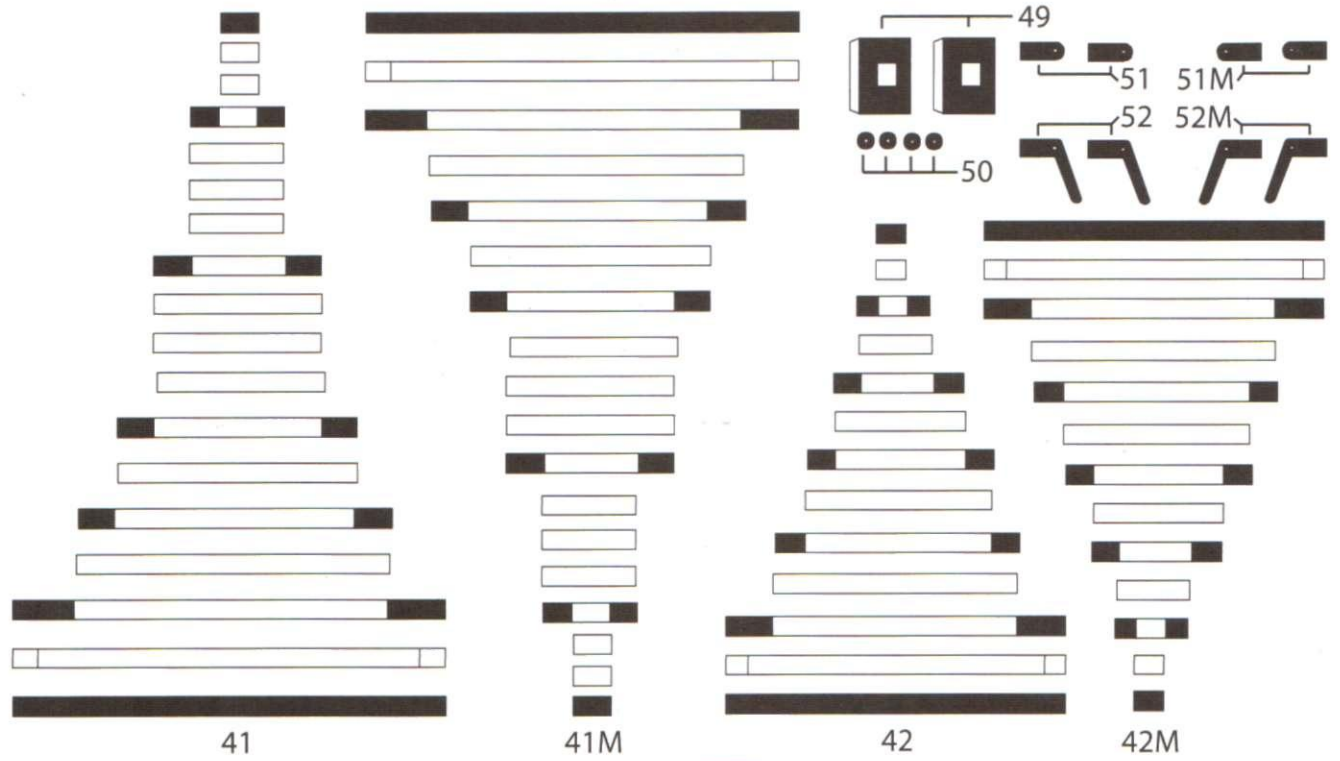

143

144

