

ALCAN

serie ORO

Design by Chema Alvarez

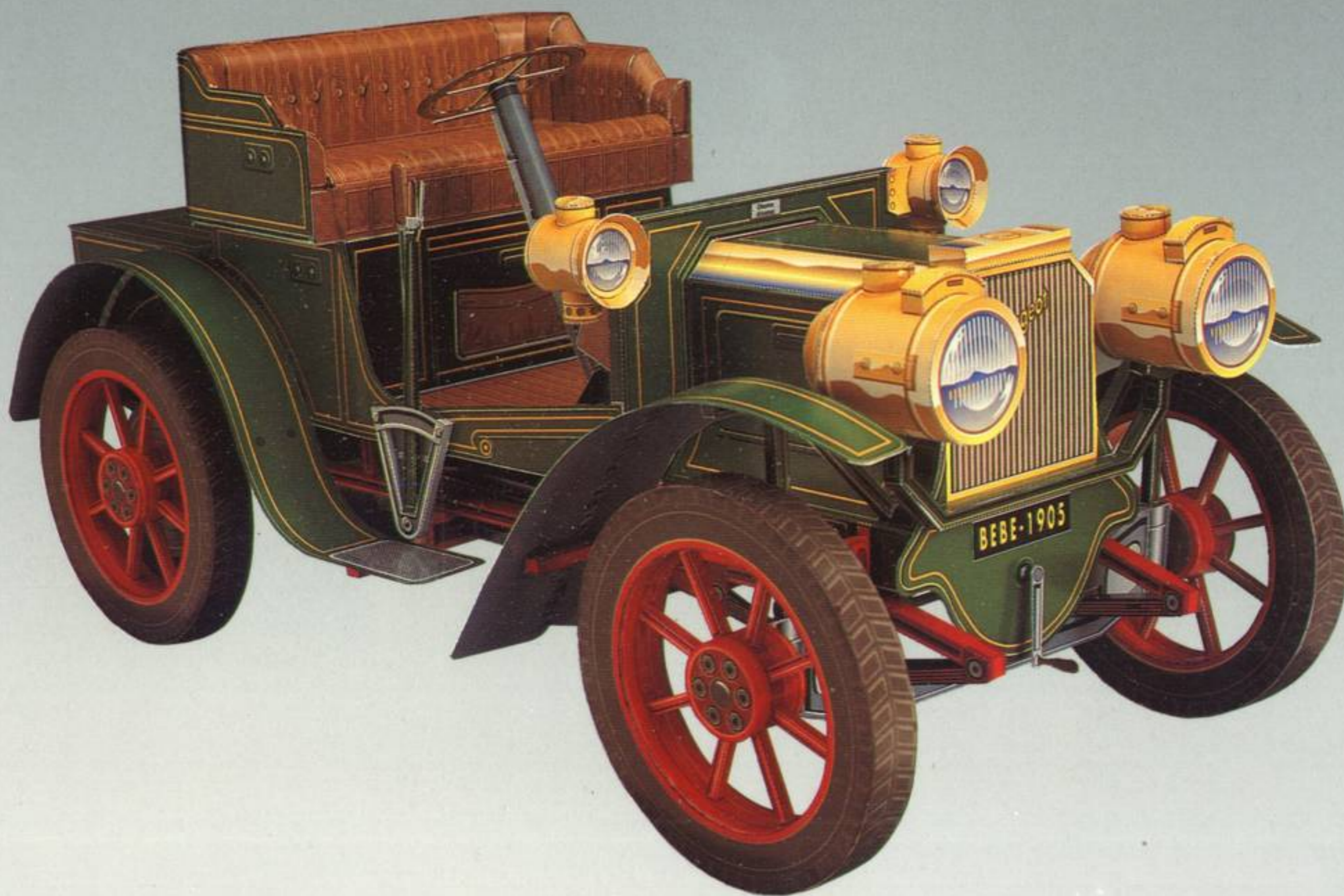

Peugeot

1905 BEBE

Contiene 202 piezas recortables

Contains 202 cutout pieces

Contient 202 pièces découpables

Enthält 202 ausschneid Teile

Contiene 202 pezzi ritagliabili

Contém 202 peças recortáveis

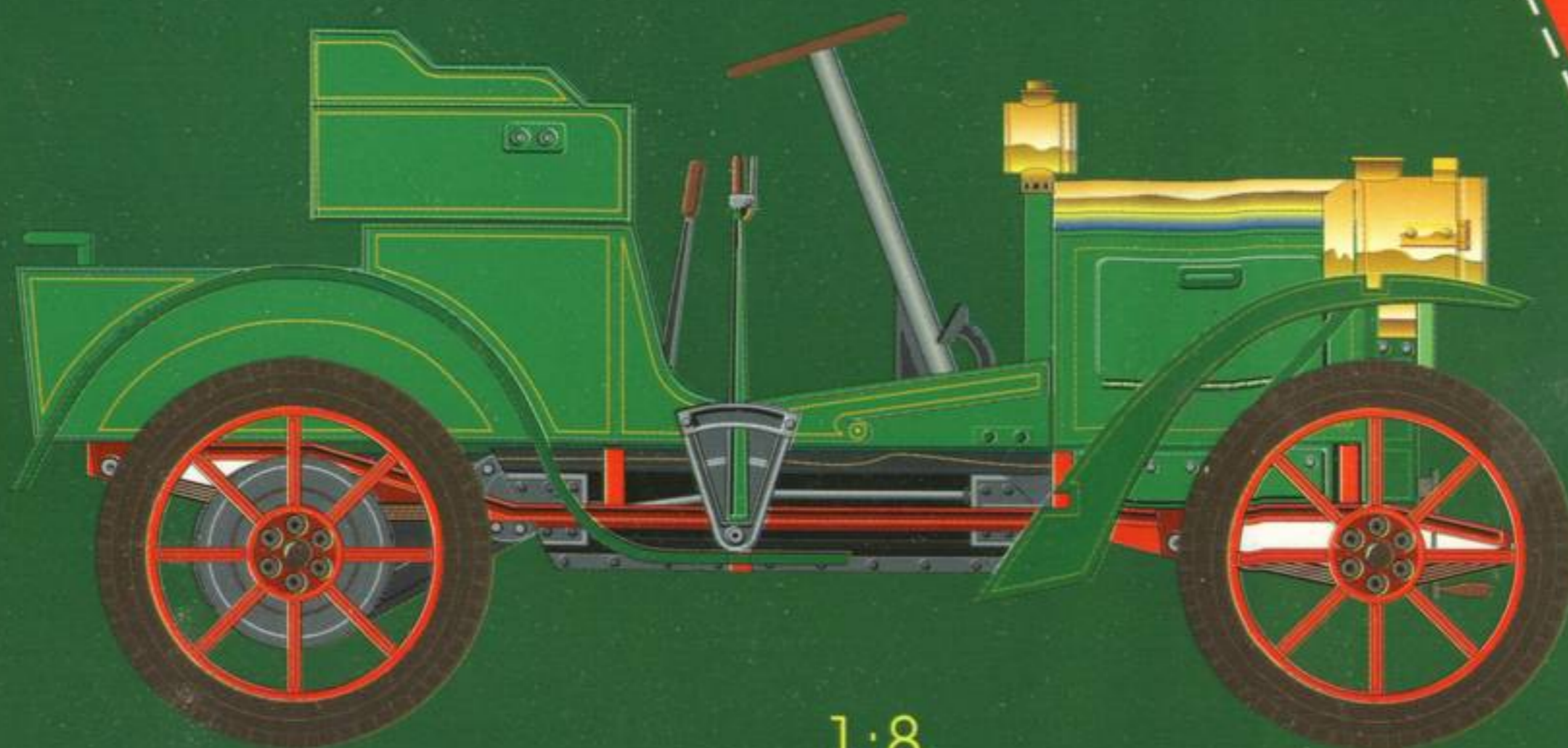

1:8

35 ctms.

Peugeot

BEBE

En 1903 la firma francesa Peugeot lanzó al mercado una serie de modelos denominados con el nombre de "Bebe", que pronto ganaron el agrado del público de principios de siglo, y llegaron a ser, uno de los coches más populares de la época.

Se trataba de un pequeño automóvil deportivo de dos plazas, con un motor de 6 HP. monocilíndrico encendido por ruptor y transmisión por cadena, que desarrollaba una velocidad de 40 Km/h.

Una de las principales innovaciones que presentaba este modelo, fué la incorporación de frenos a las cuatro ruedas.

El modelo que presentamos en este recortable corresponde al modelo de 1905.

Im Jahre 1903 brachte das französische Unternehmen Peugeot eine Serie neuer Modelle mit dem Namen "Bebe" auf den Markt. Diese gewann Anfang des Jahrhunderts sehr bald die Anerkennung der Bevölkerung und verwandelte sich in eines der populärsten Autos dieser Epoche.

Es handelte sich hier um ein kleines Automobil mit 2 Sitzen mit einem einzylindrischen 4-PS-Motor, der durch eine Zündunterbrecher gestartet wurde sowie über Kettenantrieb verfügte. Es wurde eine Geschwindigkeit von 40 km/h erreicht.

Einer der Hauptinnovationen, die dieses Modell darstellte, war die Eingliederung von Bremsen für die vier Räder.

Das Modell, das wir in diesem Bogen vorstellen, entspricht dem Modell von 1905.

In 1903, the French firm, Peugeot, launched a series of models by the name of "Bebe" which soon drew the attention of the public at the turn of the century, to such an extent that they became one of the most popular cars of the time.

It was a small two-seater sports automobile with a 6 h.p. single cylinder engine with contact breaker start and chain drive able to reach speeds of 40 km/h.

One of the main innovations of this model was the use of a four wheel breaking system.

This cut-out model is the 1905 version.

Nel 1093 la ditta francese Peugeot lanciò sul mercato una serie di modelli denominati col nome di "Bebe", che presto ha guadagnato il gradimento del pubblico del principio del secolo, ed è stata una delle macchine più popolari dell'epoca.

Si trattava di una piccola automobile sportiva da due posti, con un motore da 4HP monocilindrico acceso da rotore e trasmissione a catena, che sviluppava una velocità di 40 Km/h.

Una delle principale innovazione che presentava questo modello, era la incorporazione di freni nelle quattro ruote.

Il modello che presentiamo in questo ritagliabile corrisponde al modello del 1905.

En 1903, la société française Peugeot lança sur le marché une série de modèles dénommés "Bebe" qui rapidement plurent au publique du début du siècle et ils finirent par être une des voitures des plus populaires de l'époque.

Il s'agissait d'une petite voiture de sport de deux places avec un moteur de 4HP mono-cylindrique dont le démarrage s'effectuait par rupteur et transmission par chaîne, qui développait une vitesse de 40 Km/h.

Une des principales innovations que représentait ce modèle, c'était l'incorporation de freins aux quatre roues.

Le modèle que nous présentons dans cette maquette correspond au modèle de 1905.

Em 1903, a firma francesa Peugeot lançou ao mercado uma série de modelos denominados "Bebe", que rapidamente ganharam a apreciação do público de principios do século, chegando a ser um dos carros mais populares da época.

Tratava-se de um pequeno automóvel desportivo de dois lugares, com um motor monocilíndrico de 4 CV, ignição por ruptor e transmissão por cadeia, que desenvolvia uma velocidade de 40 Km/h.

Uma das principais novidades que este modelo apresentava era a incorporação de freios nas quatro rodas.

O modelo que apresentamos neste recortável corresponde ao modelo de 1905.

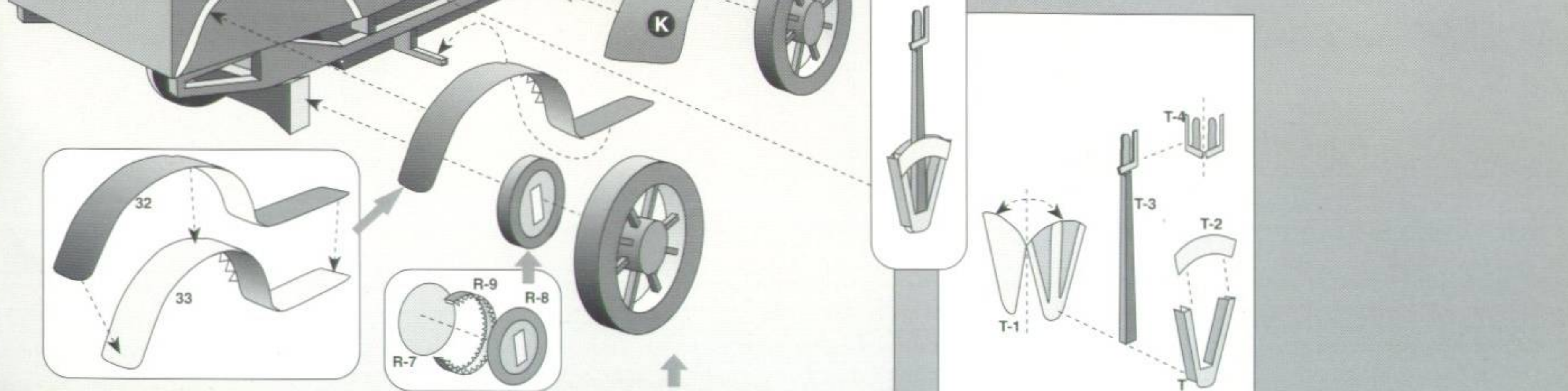
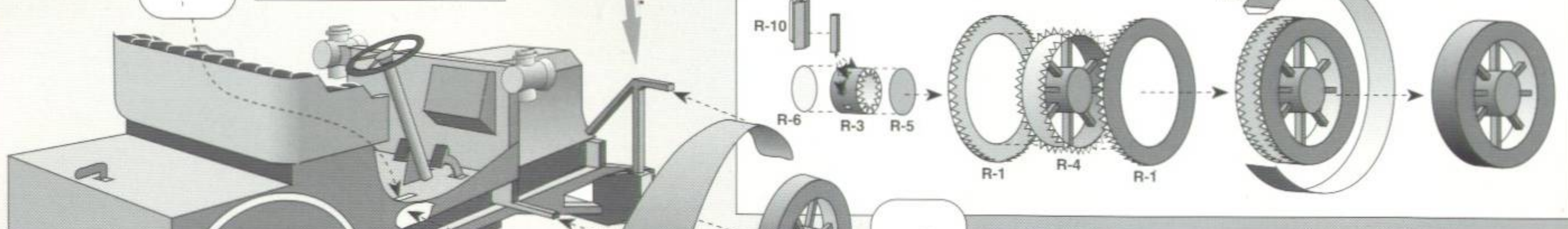
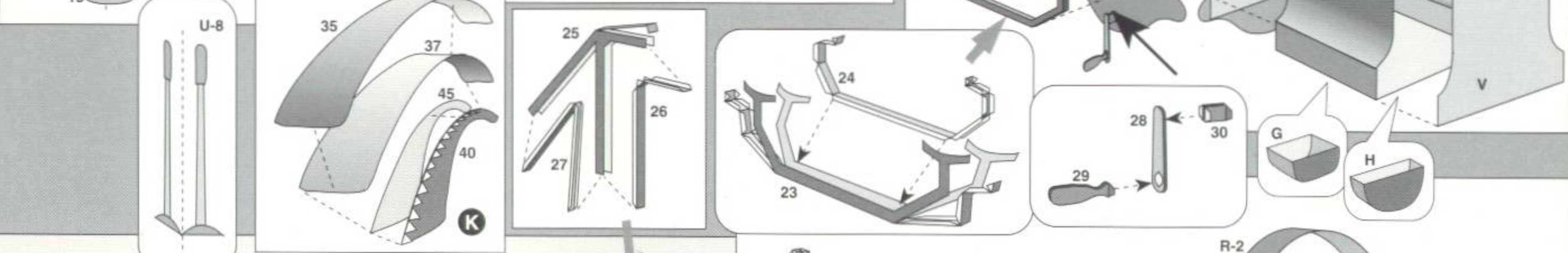
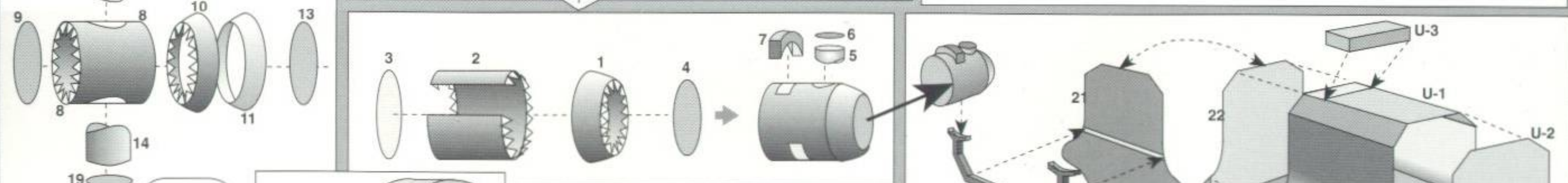
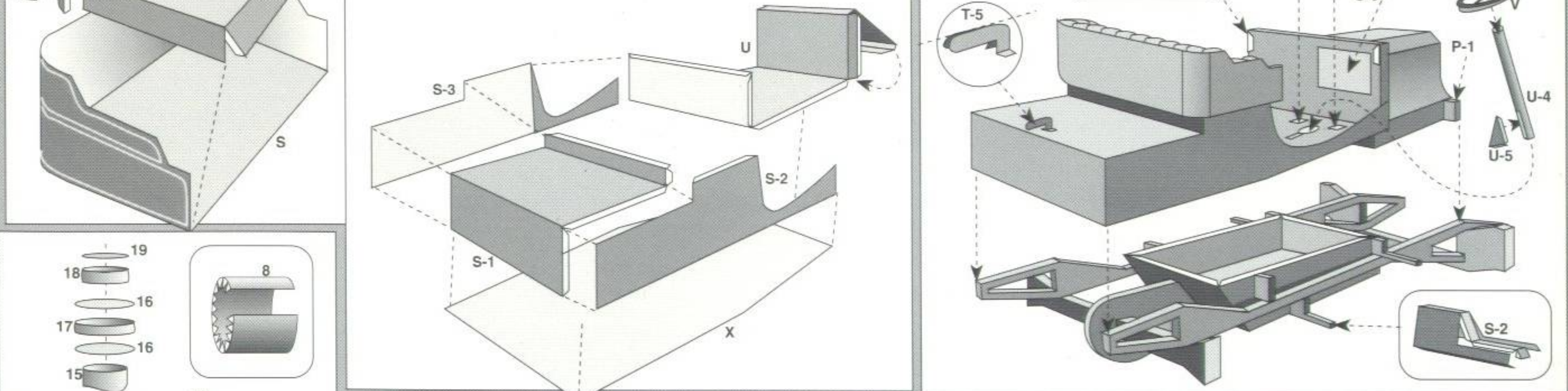
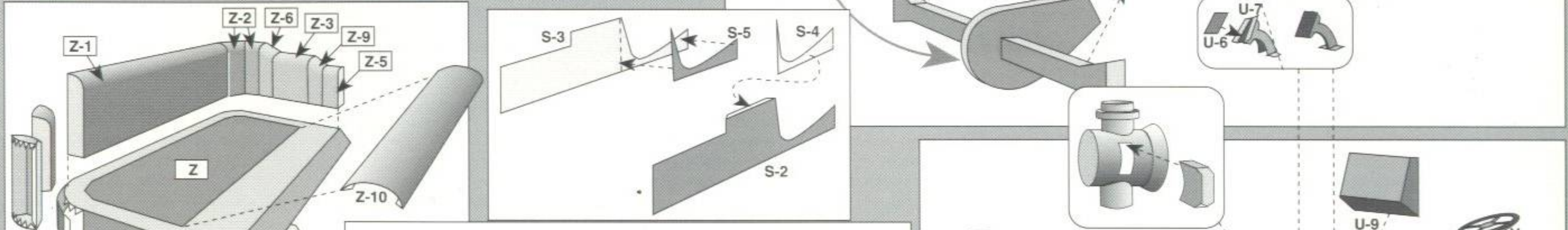
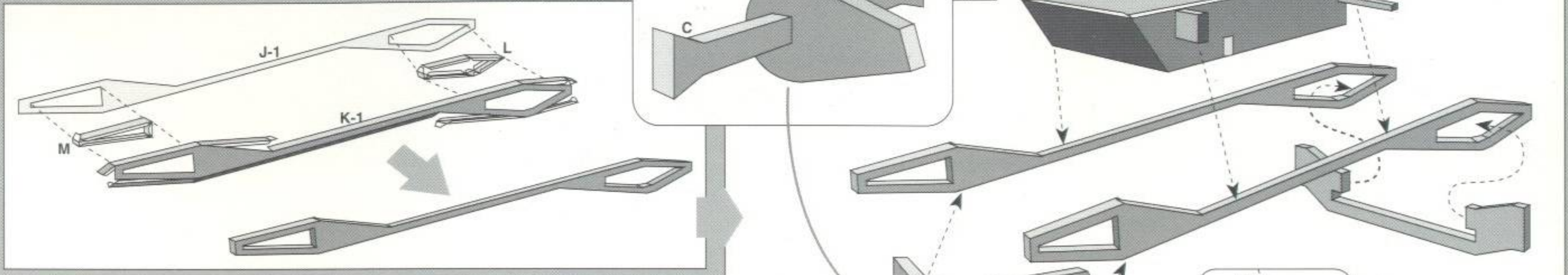
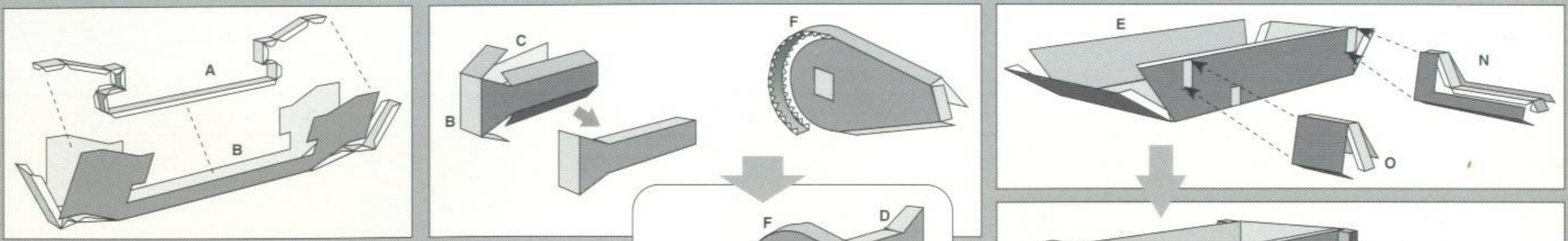

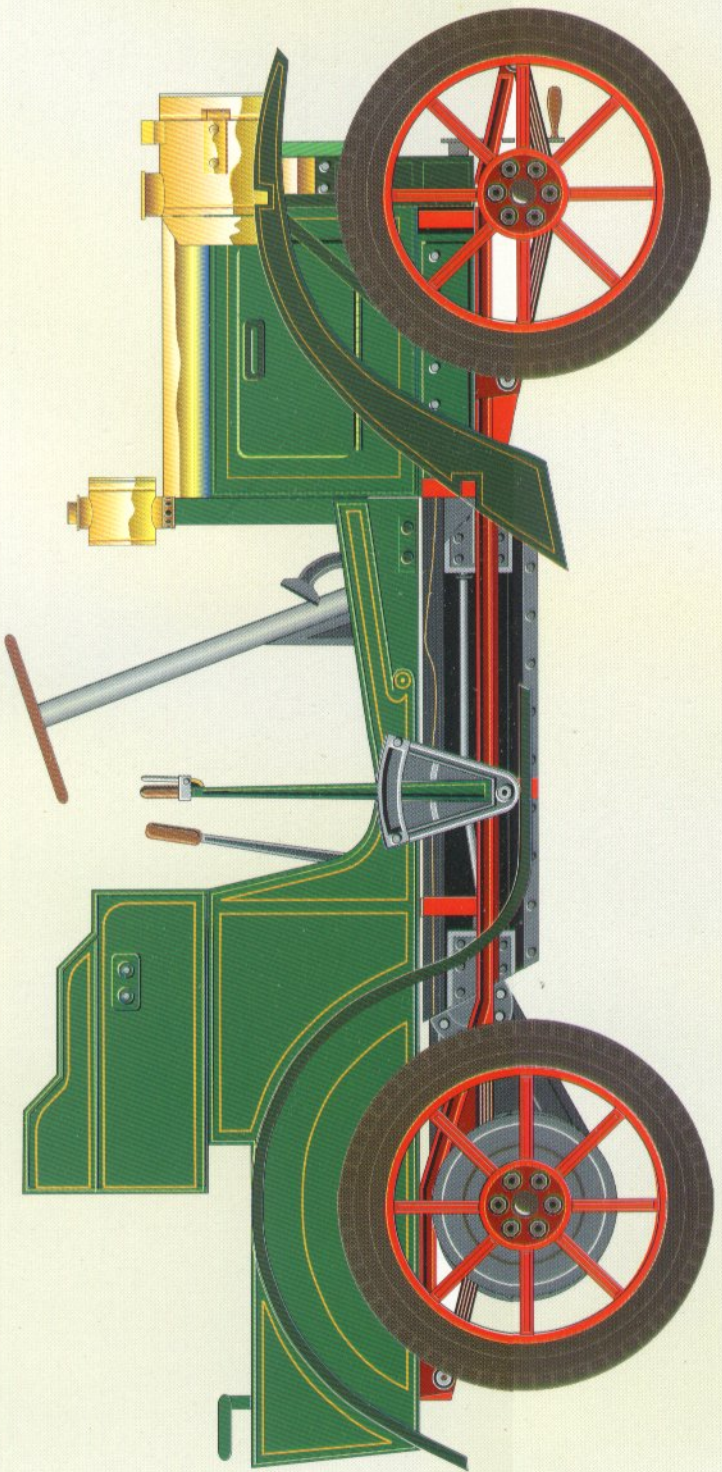

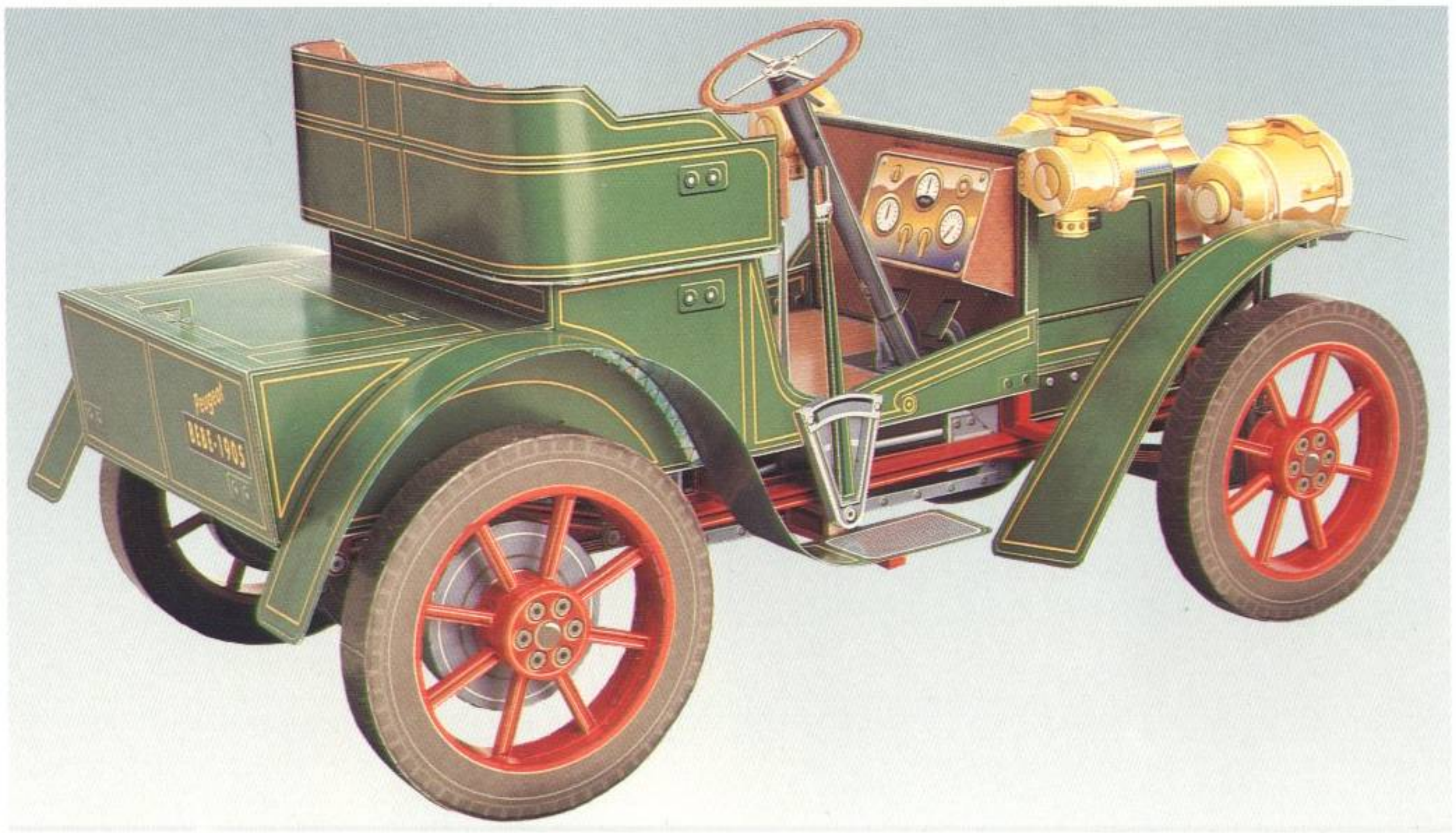

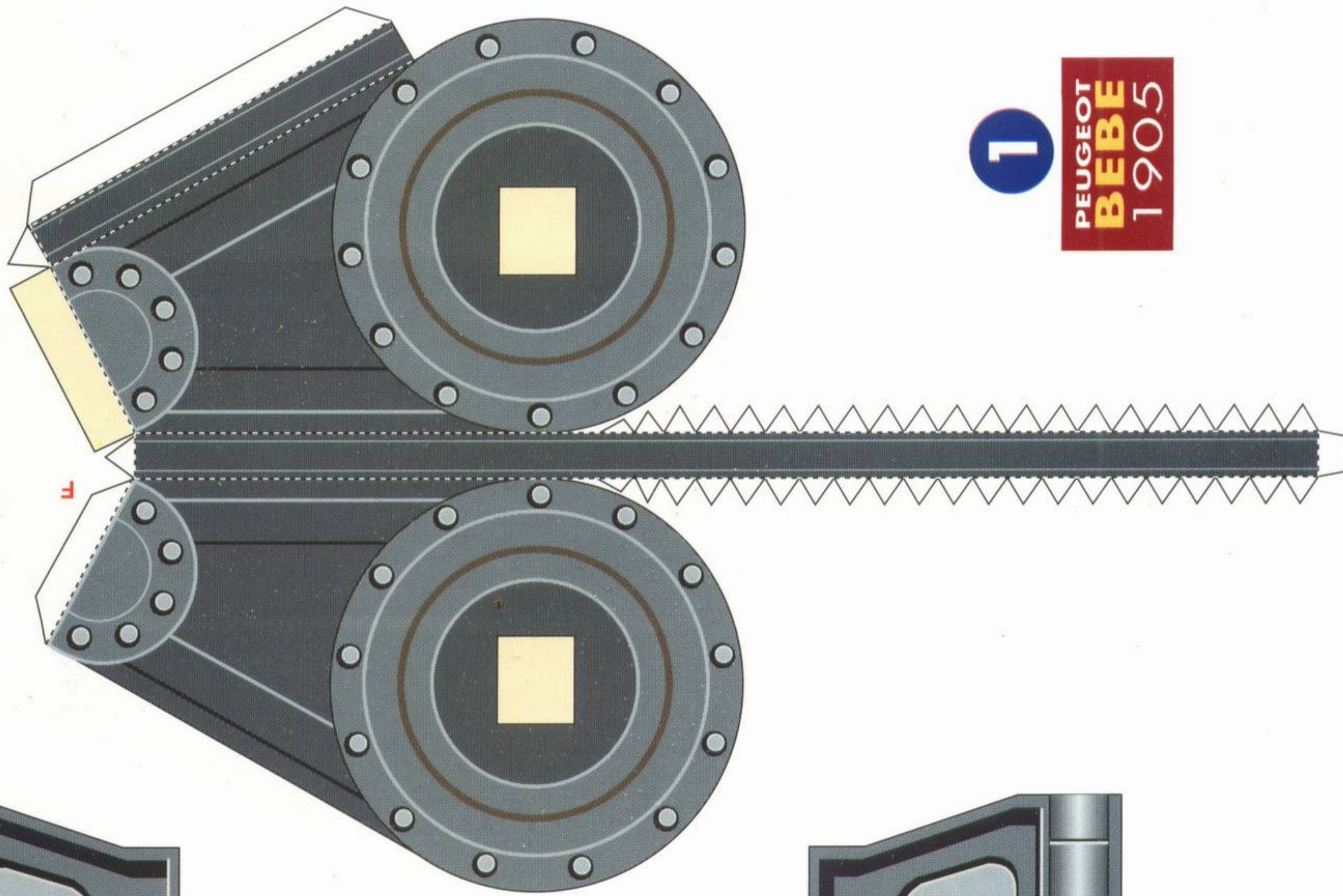
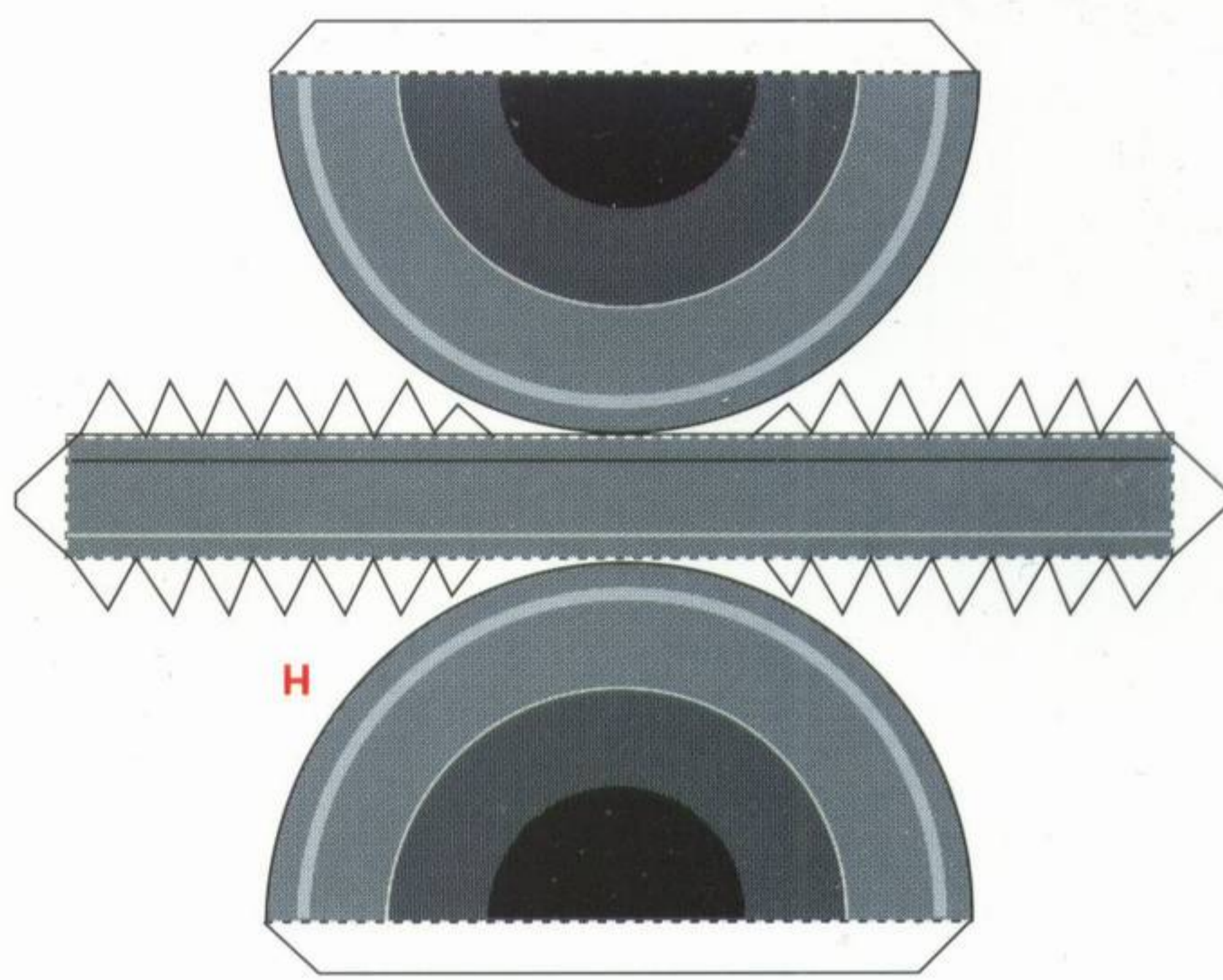
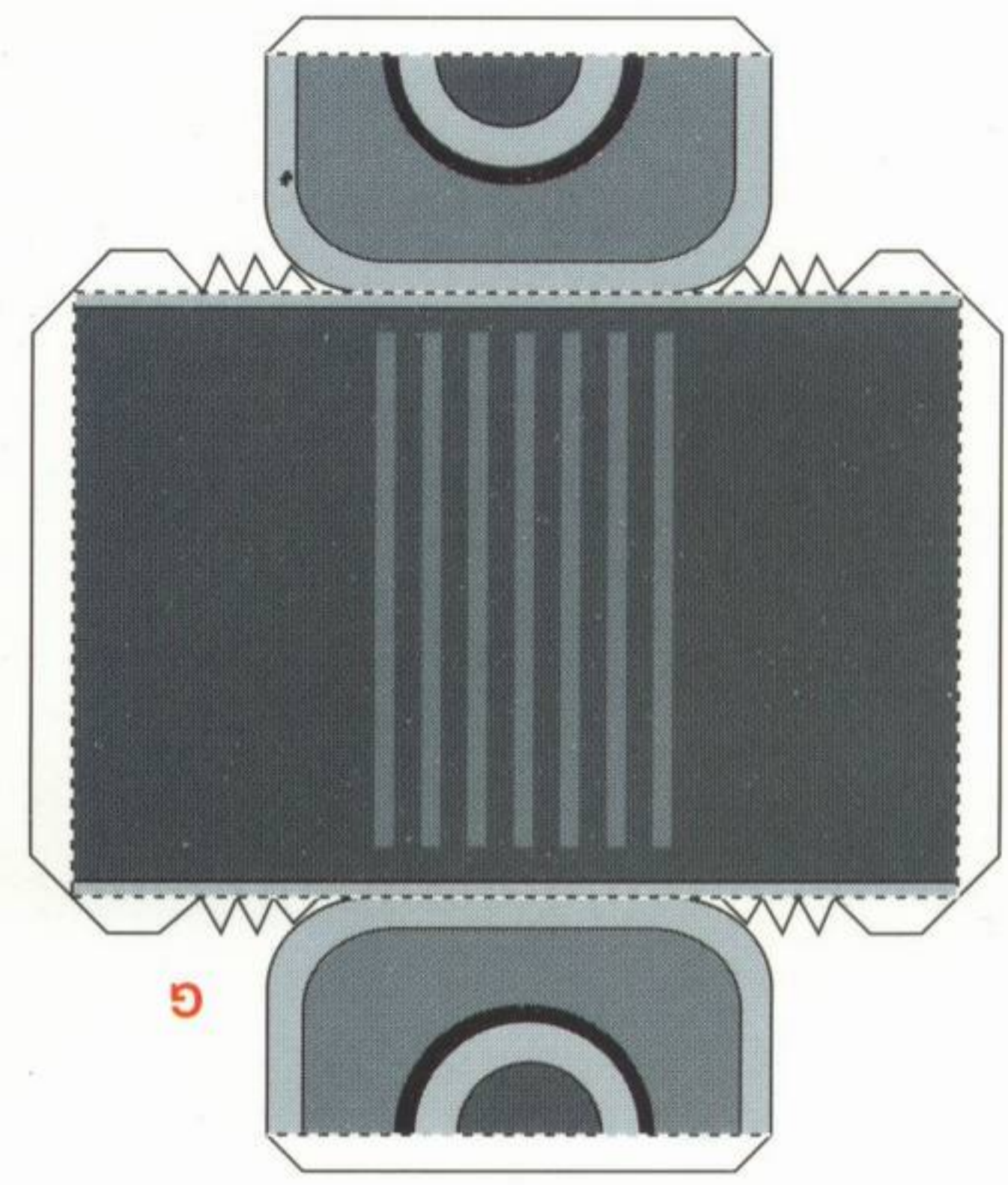
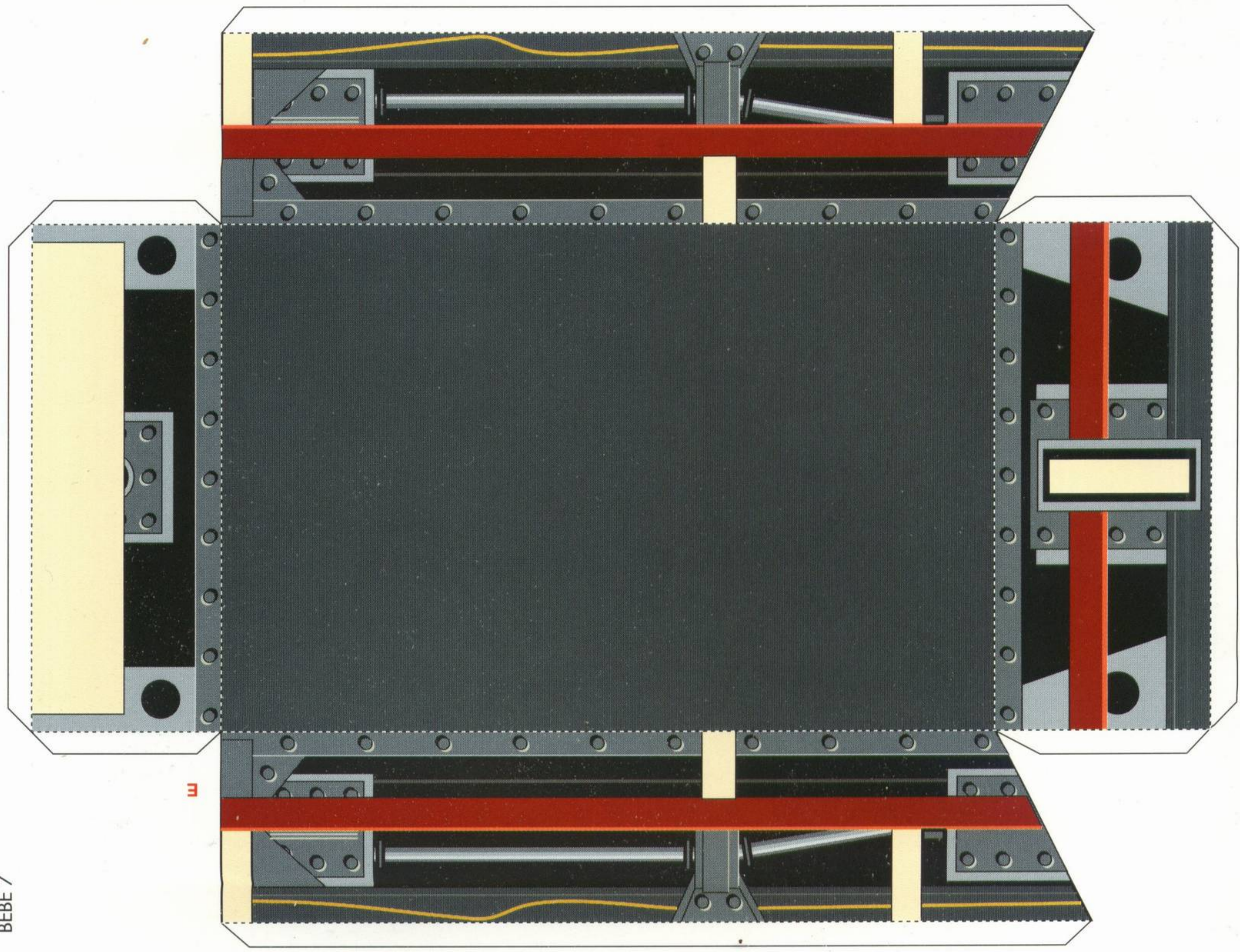

1
 PEUGEOT
BEBE
 1905

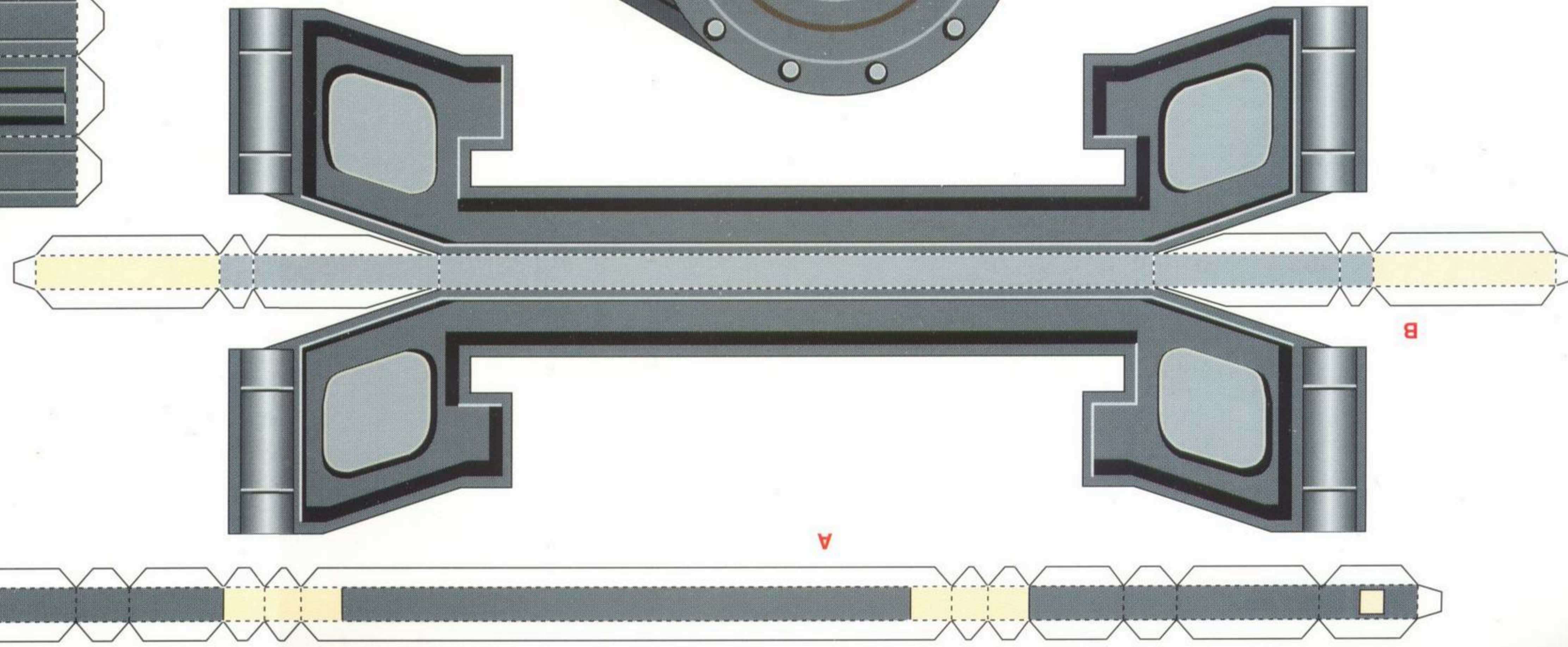
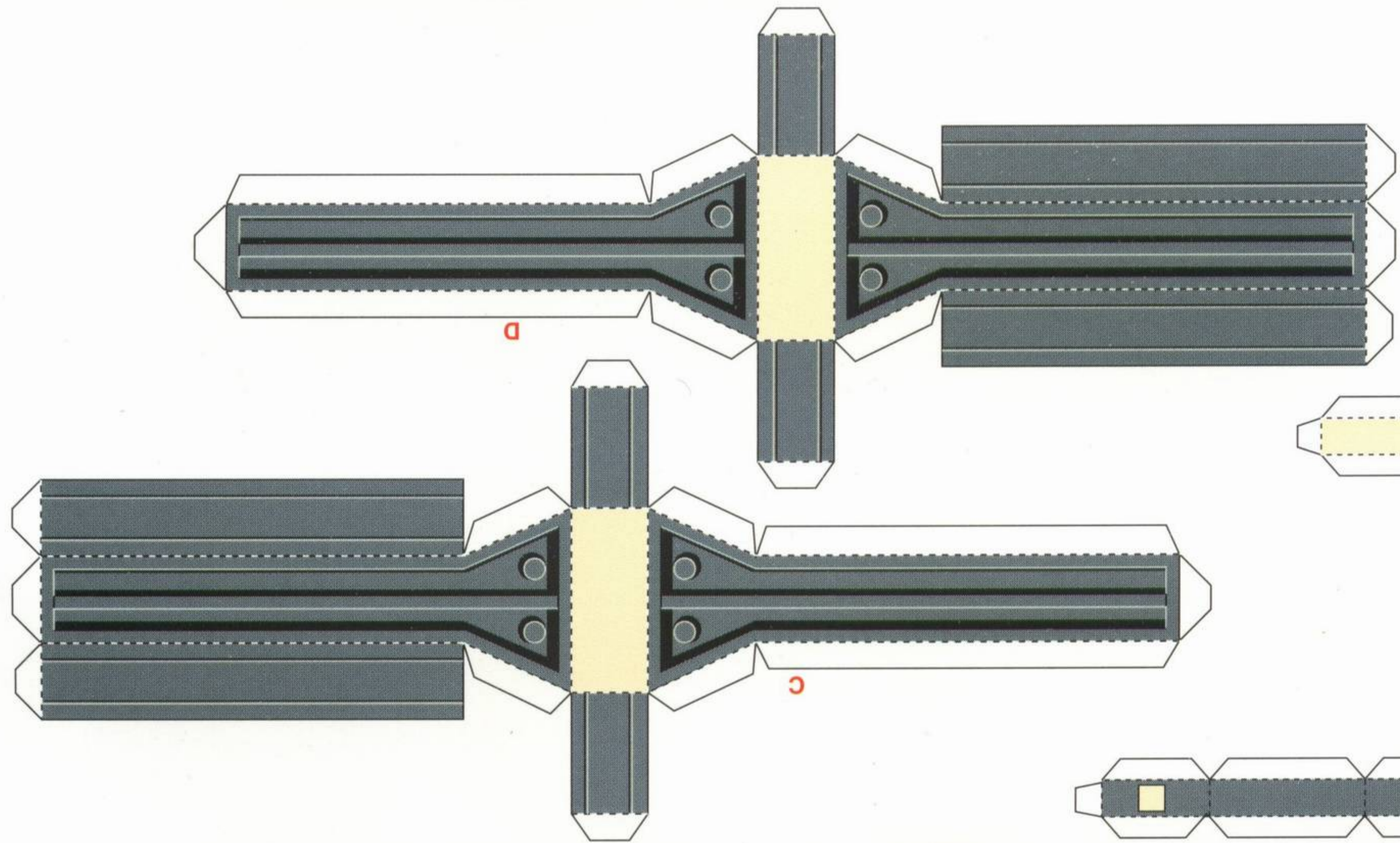

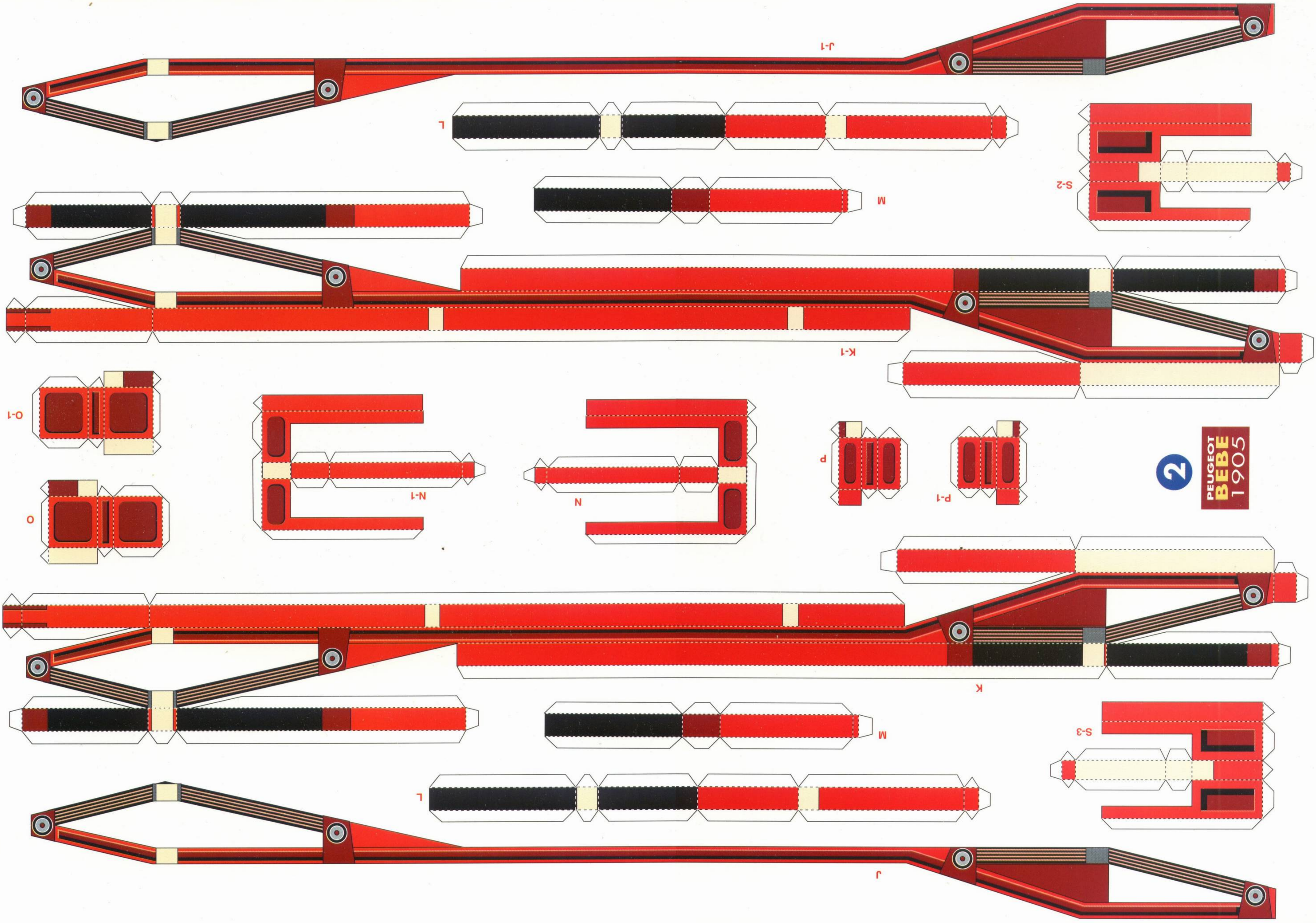

2

PEUGEOT
BEBÉ
1905

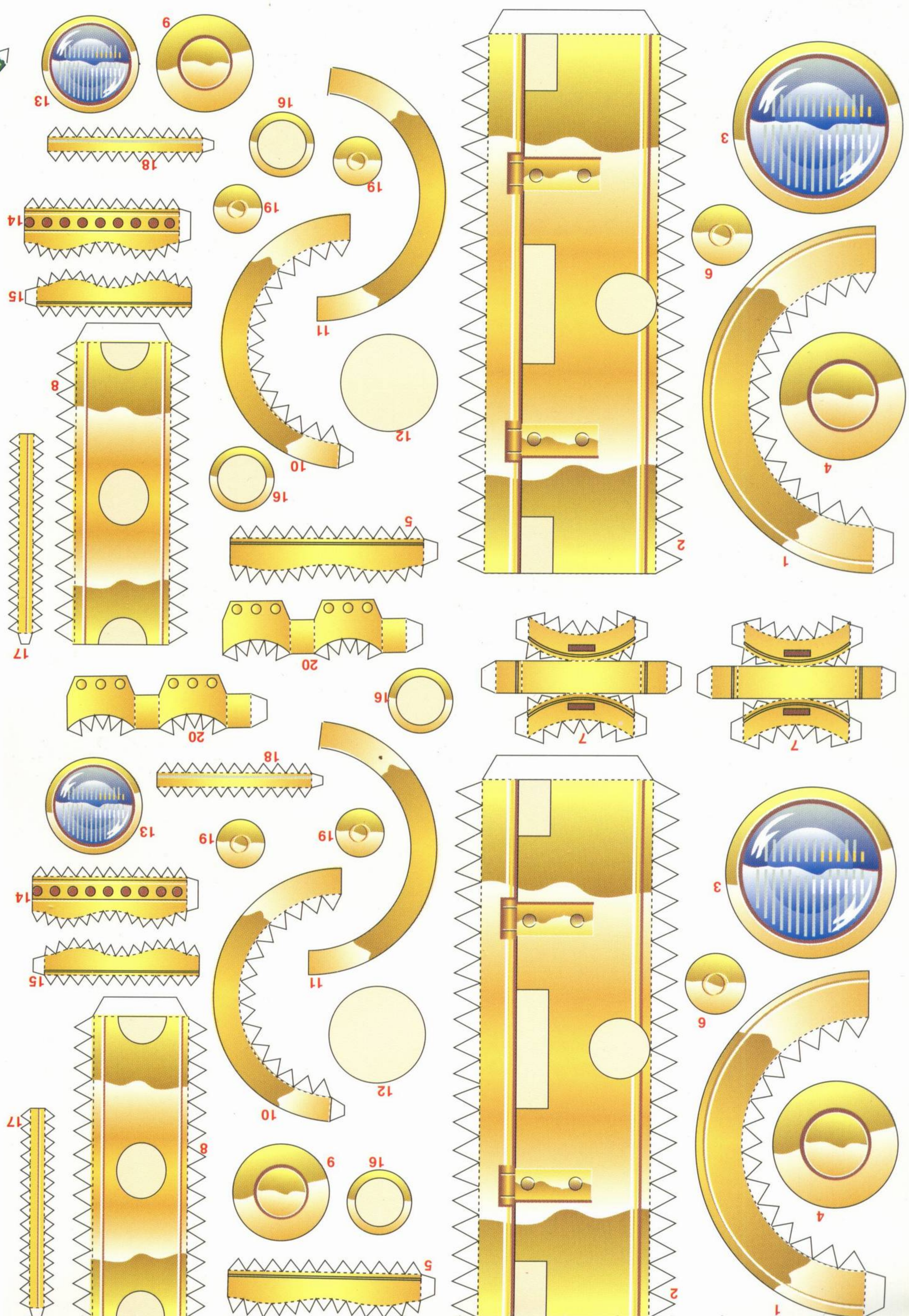
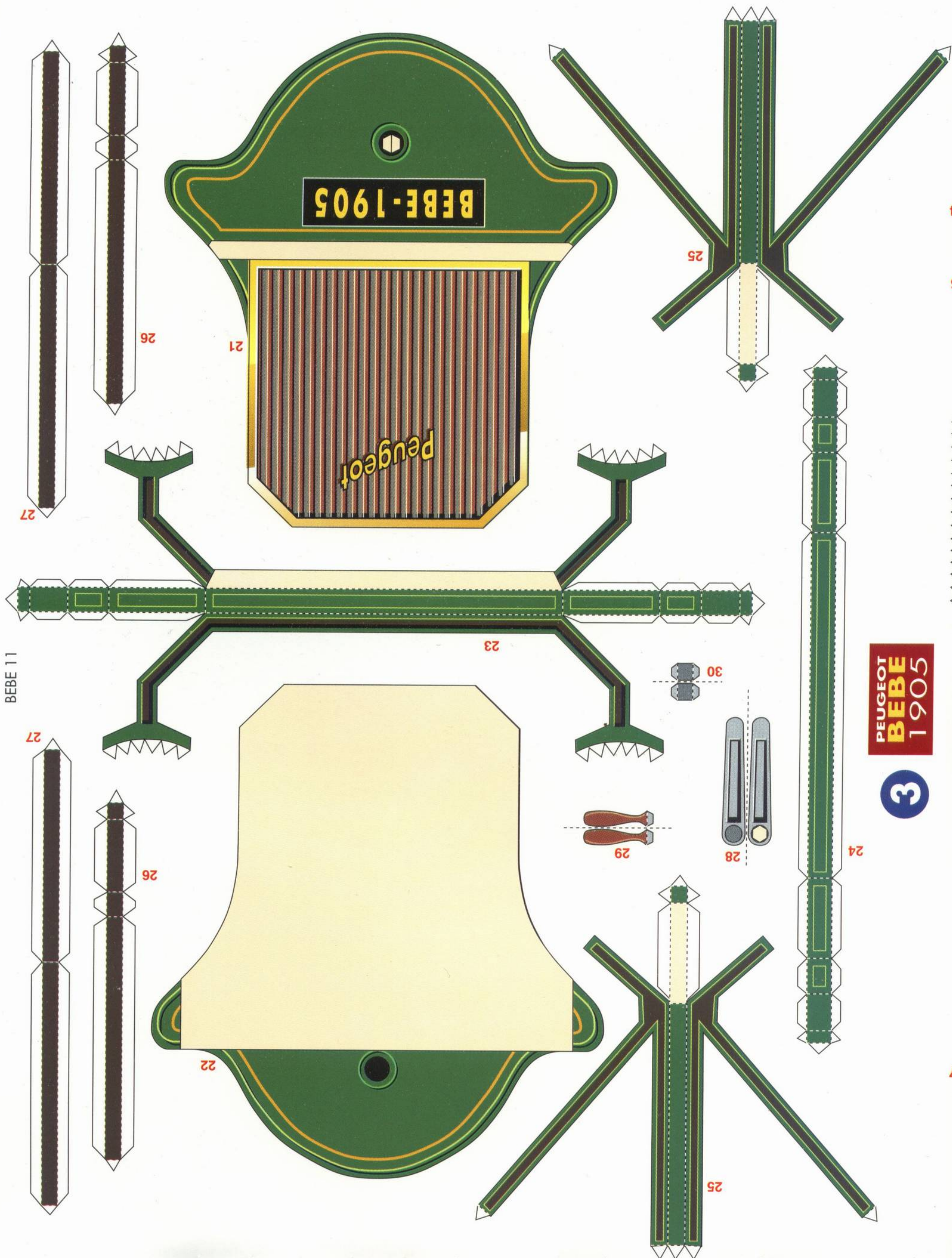

PEUGEOT
BEBE
1905

3

BEBE 11

PEUGEOT
BEBE
1905

4

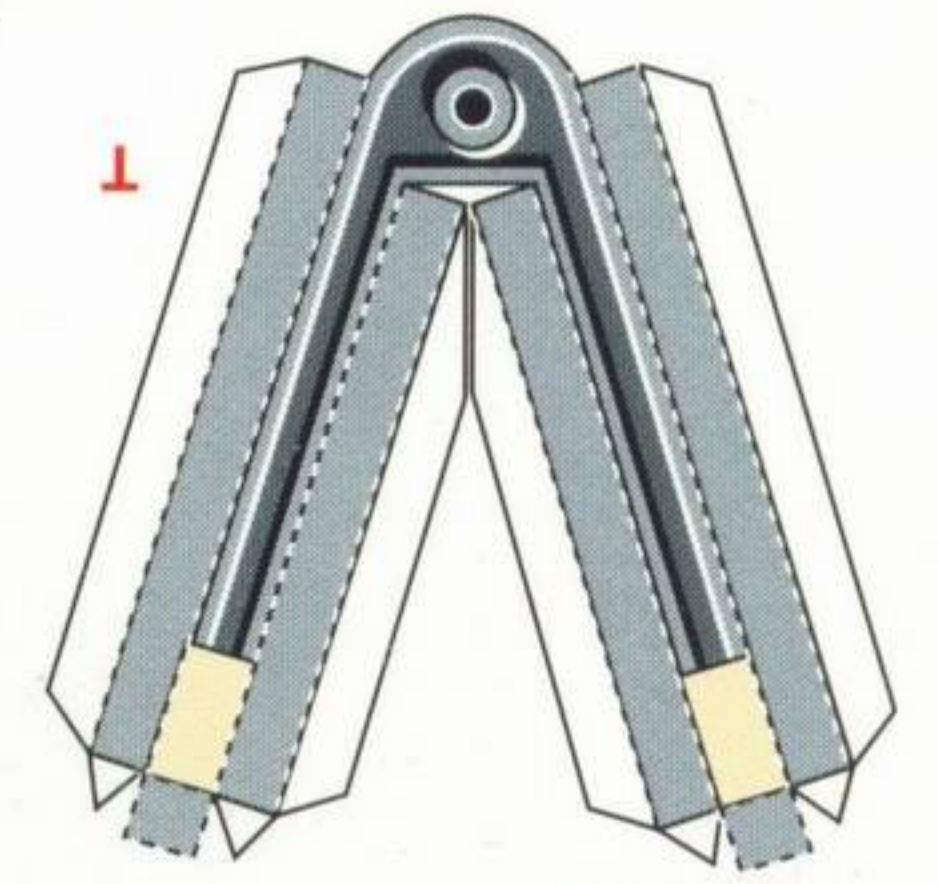
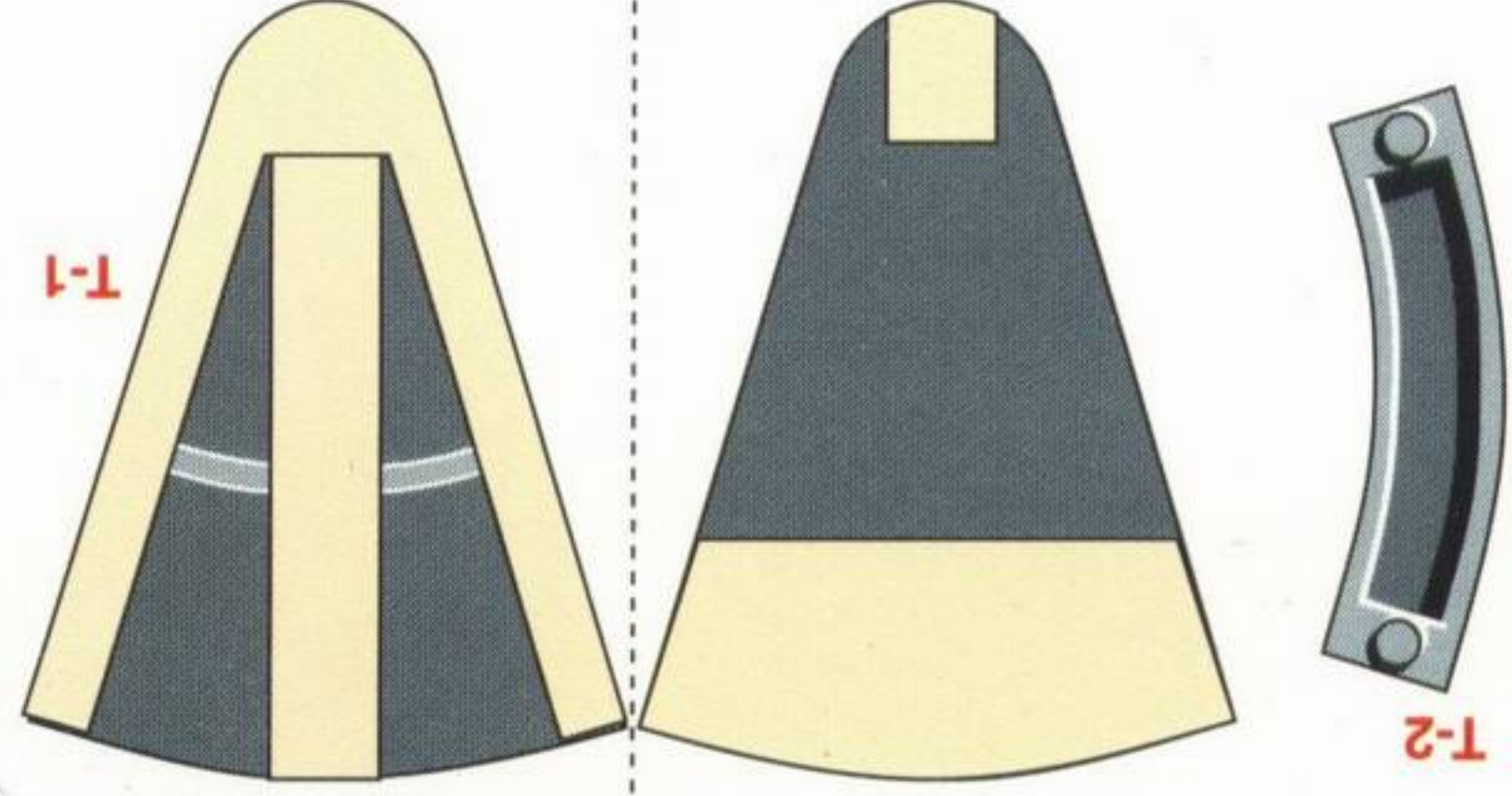

S-1

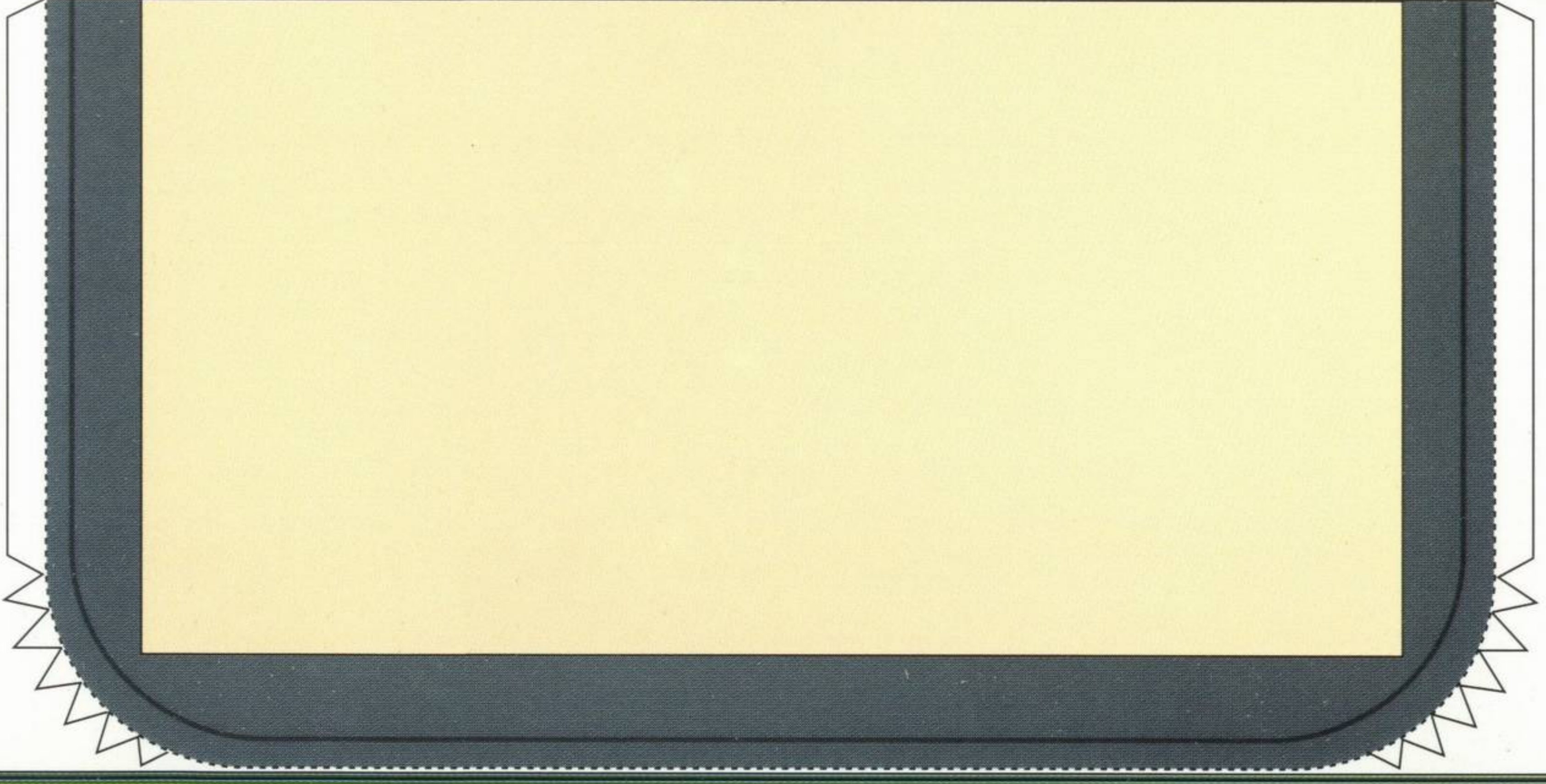
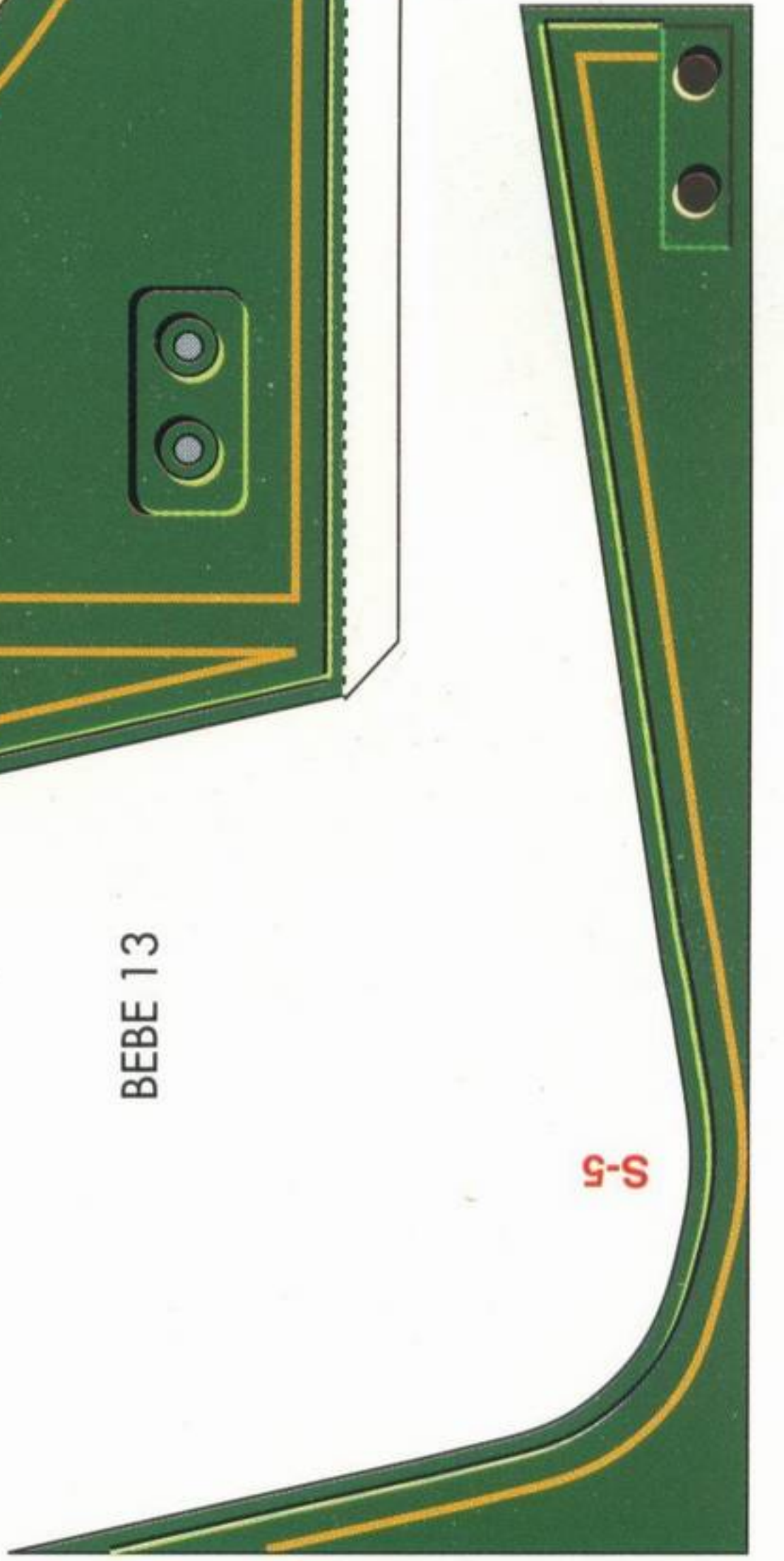
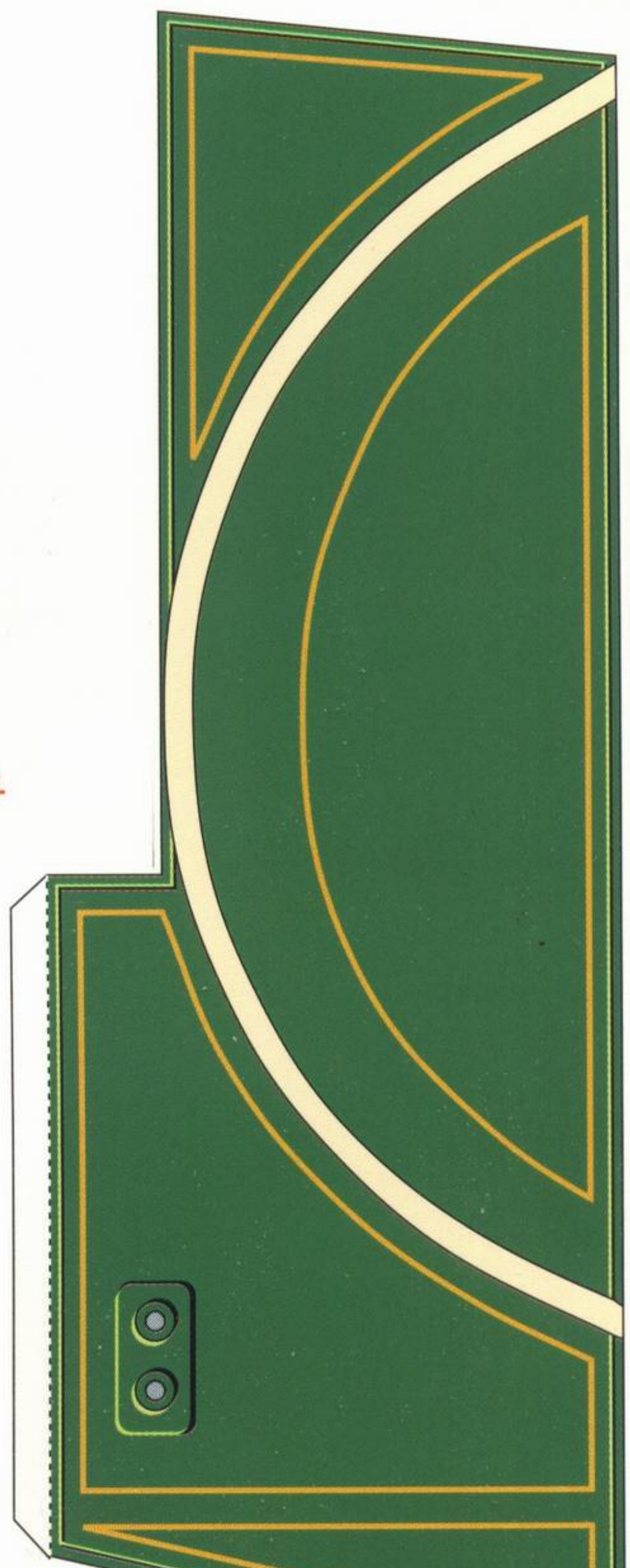
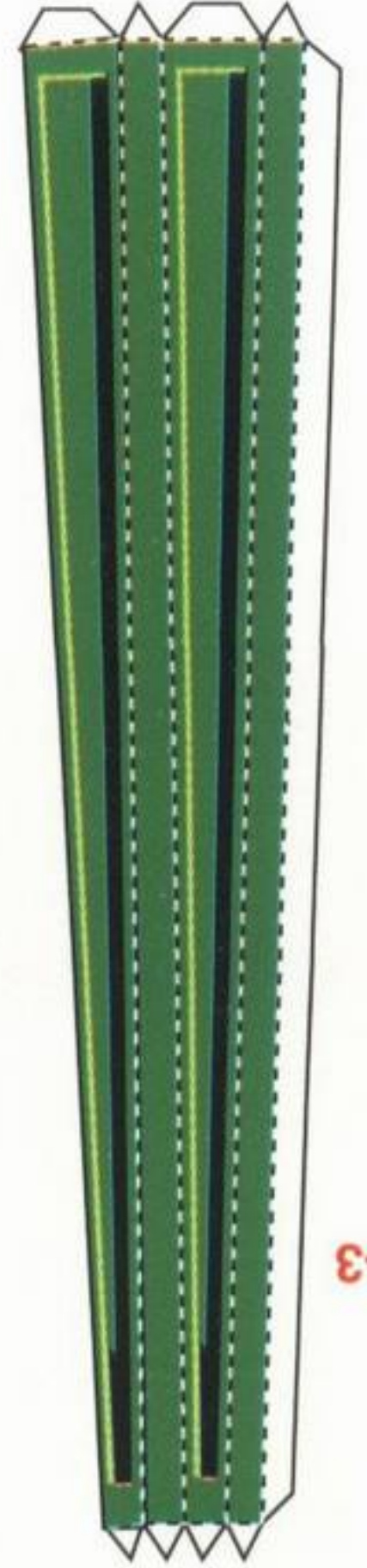
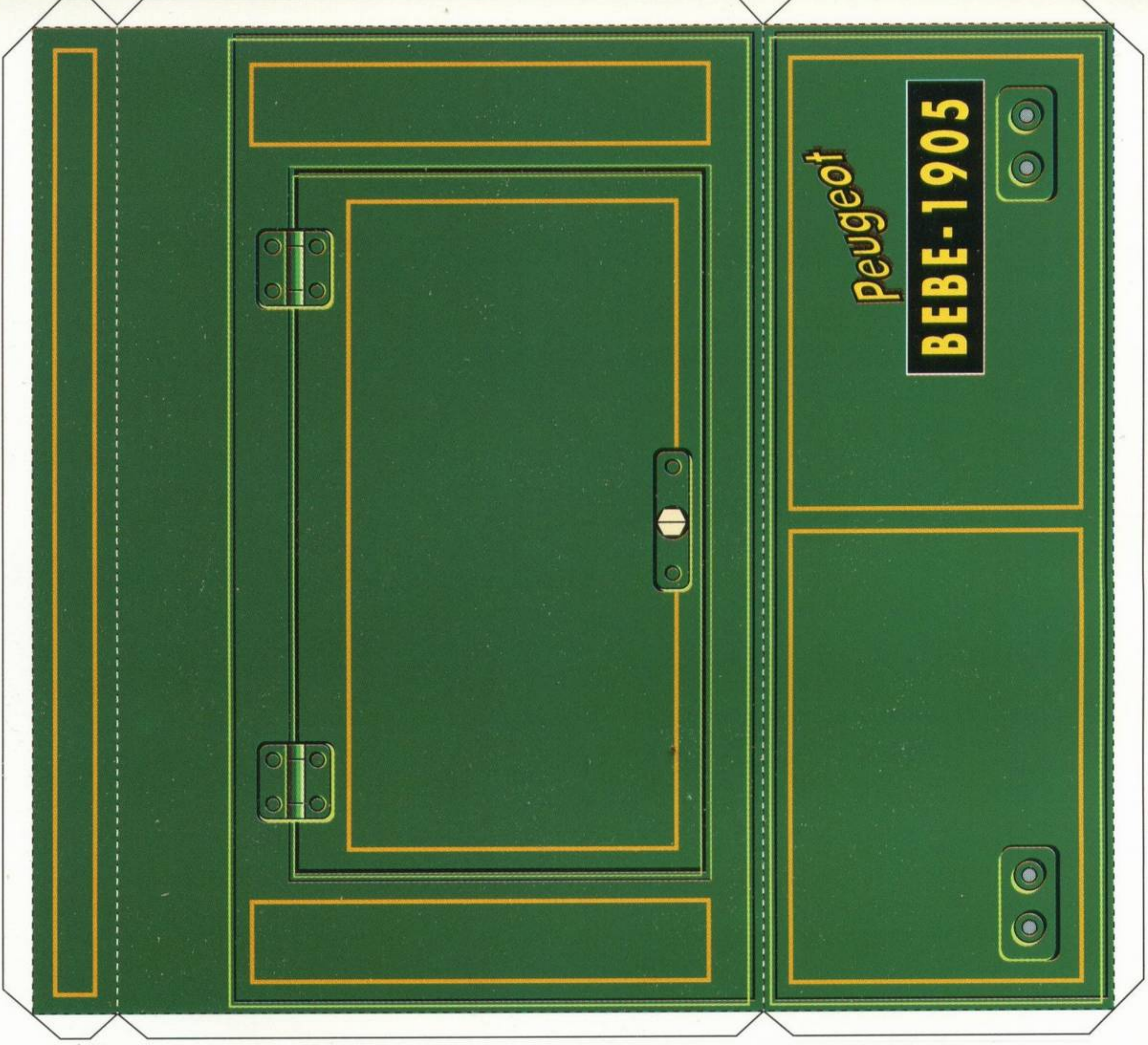

S-4

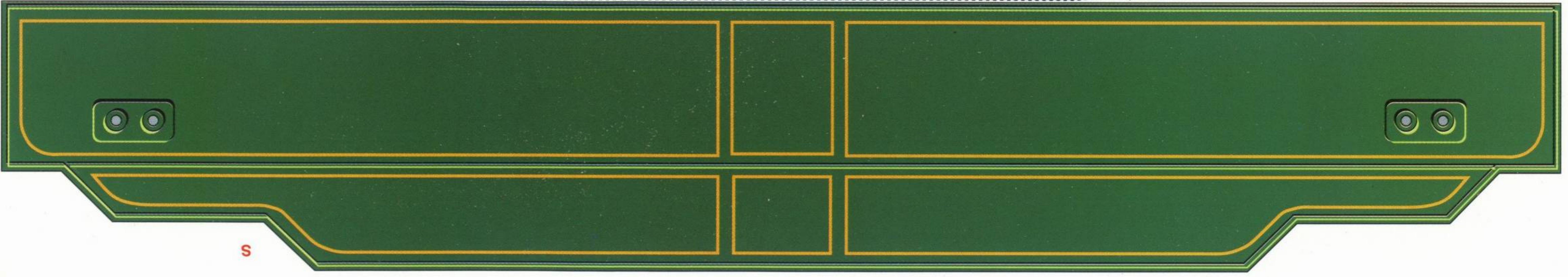
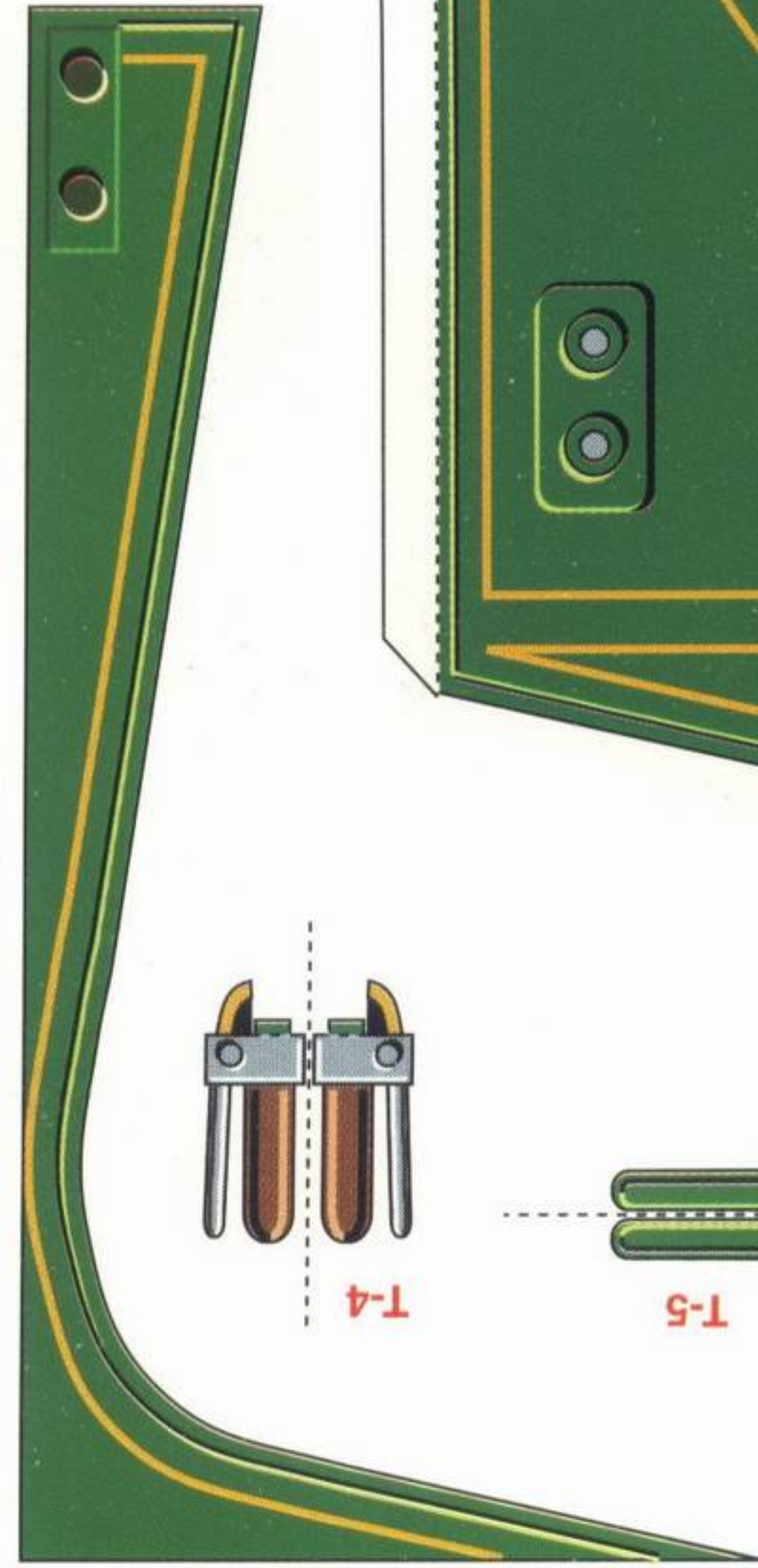

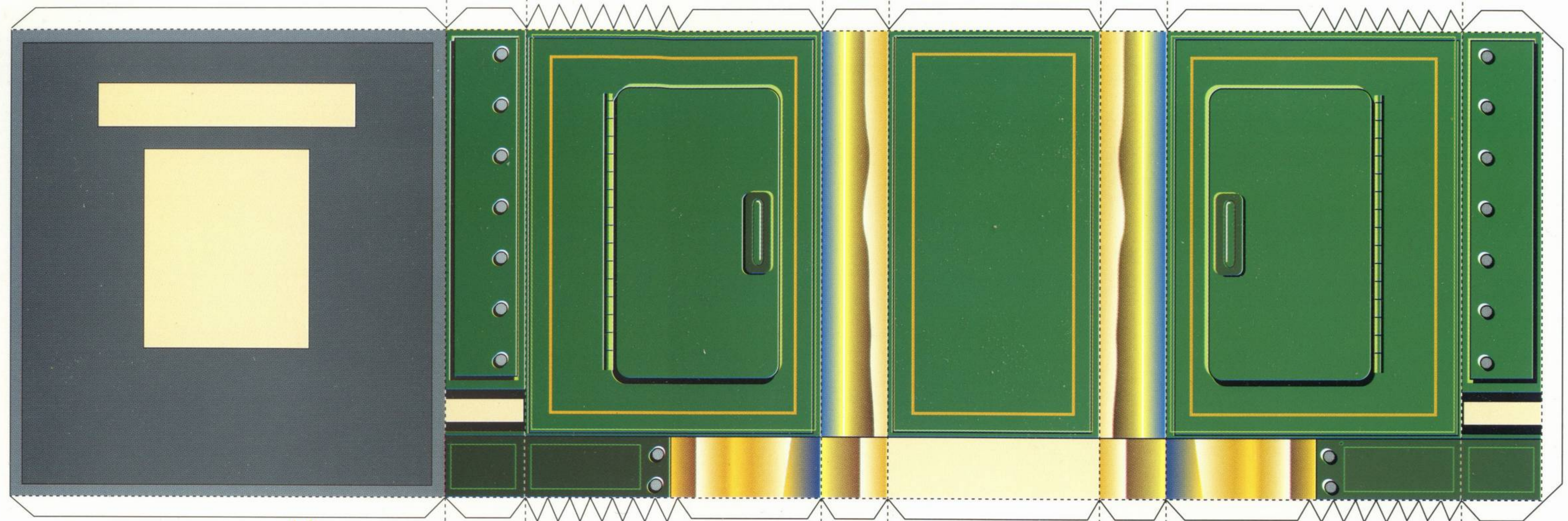

U-1

U-6

U-3

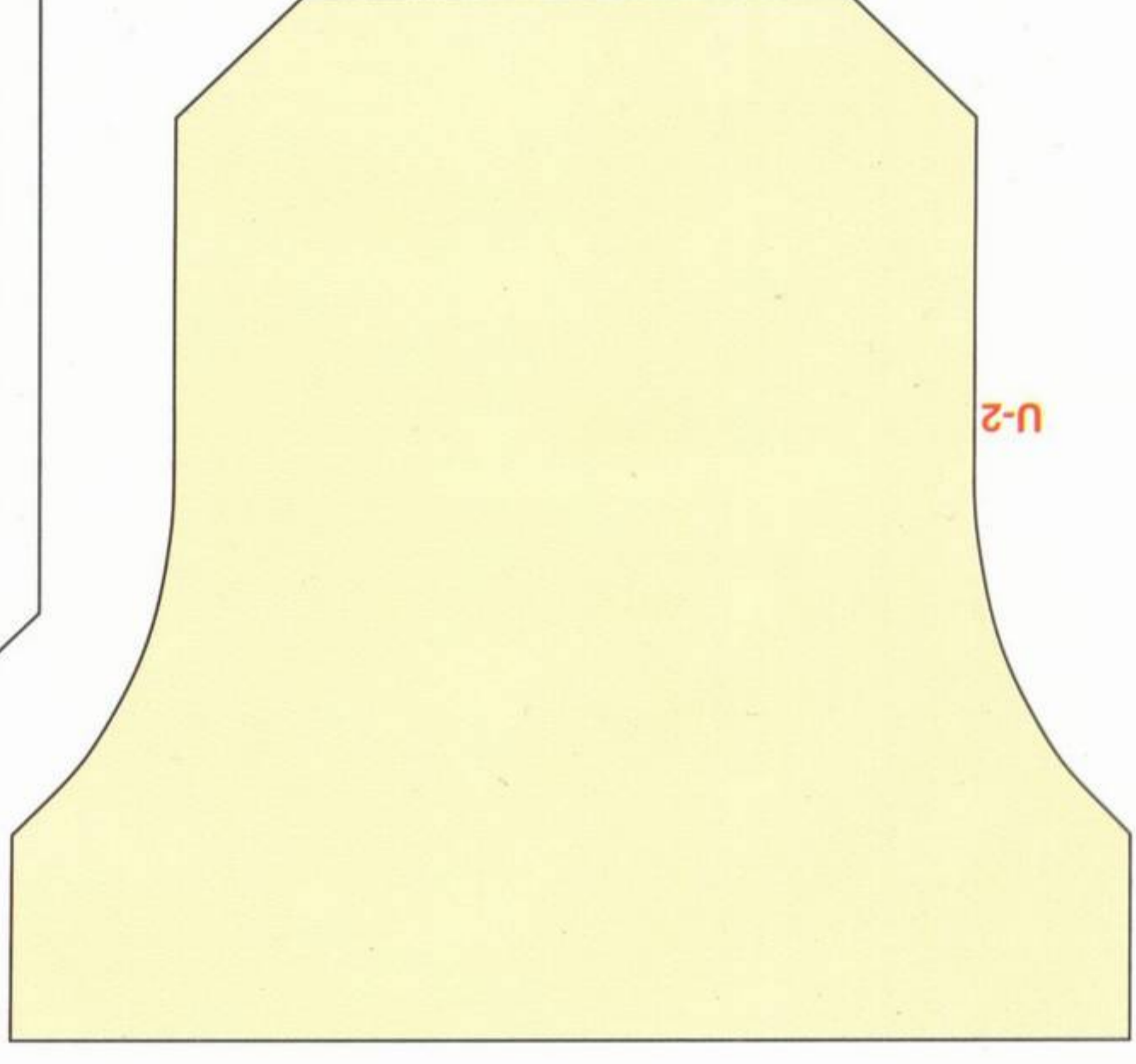
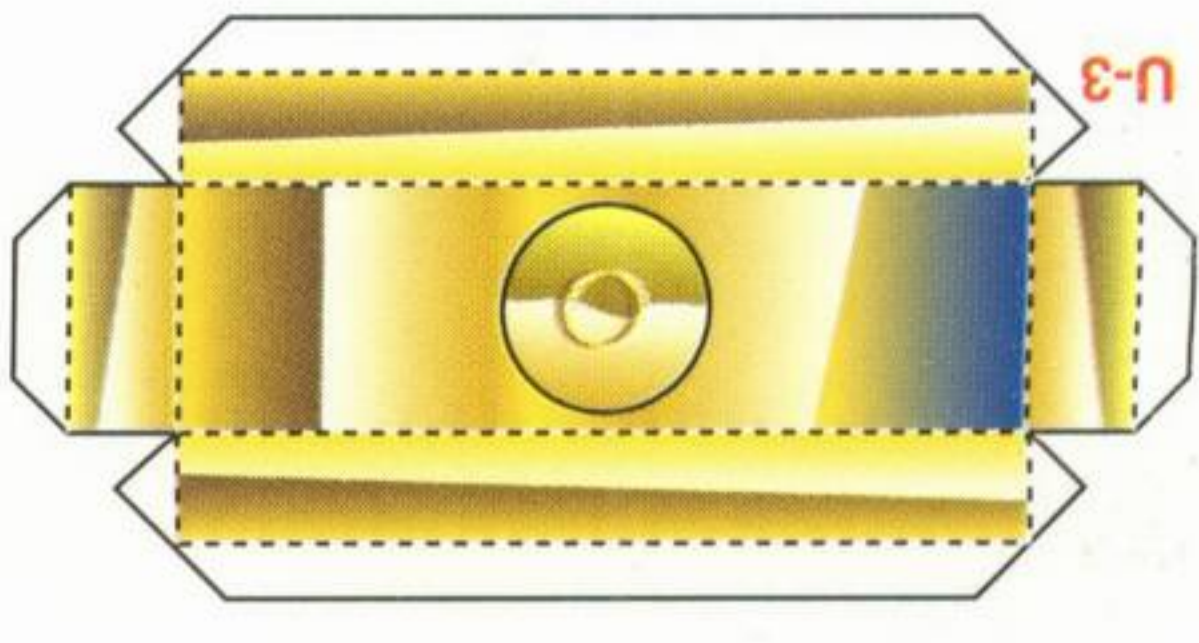

U-2



U-4

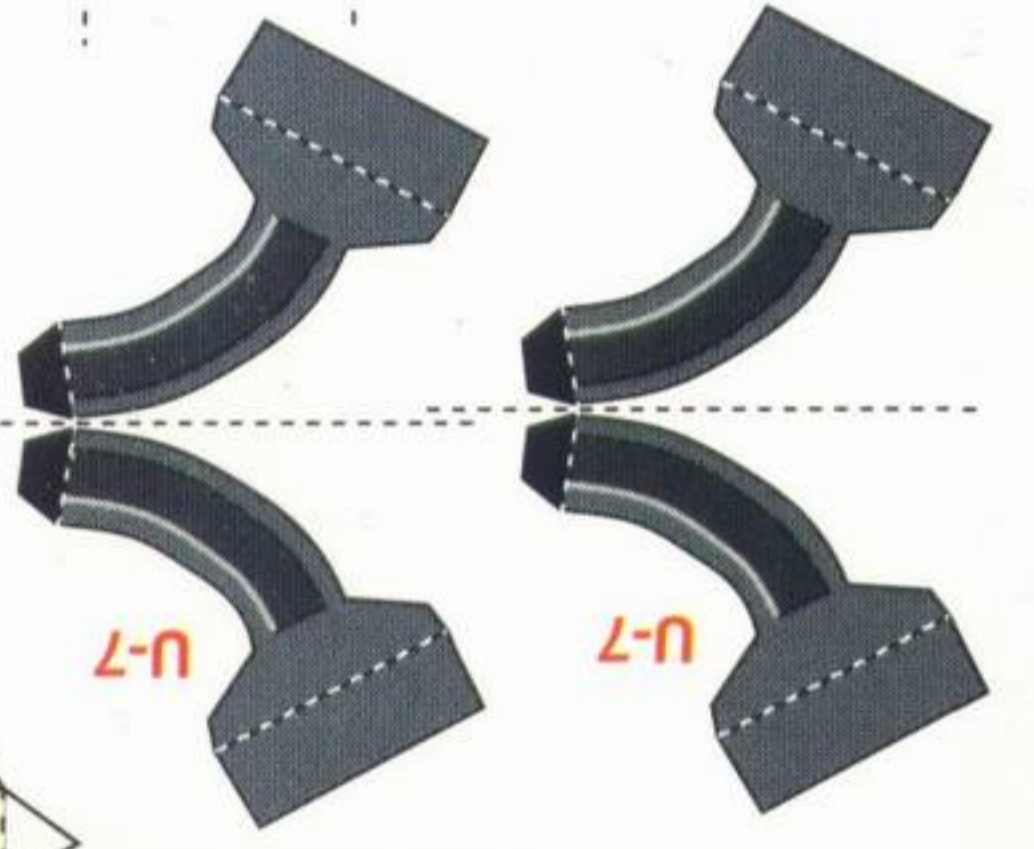

U-7

U-7



U-8



U-5



U-9

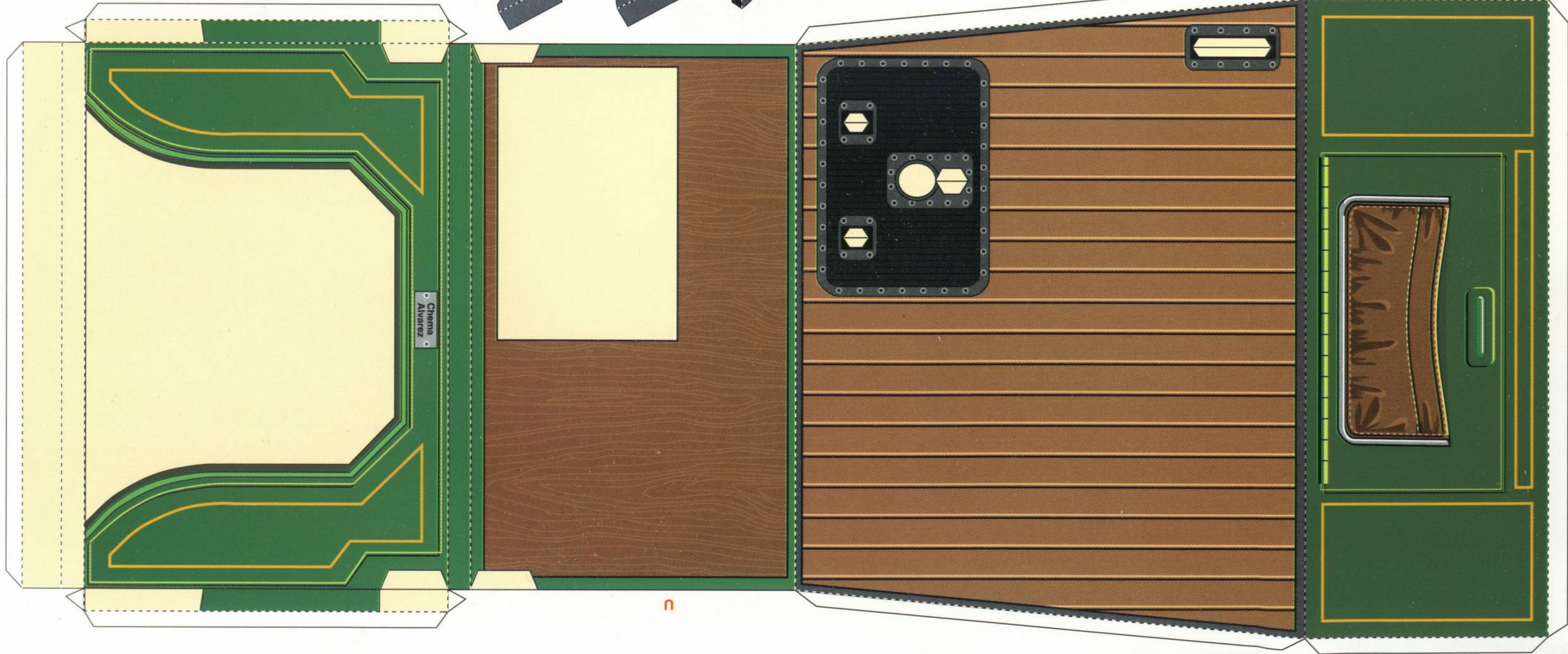

U

PEUGEOT
BEBE
1905

5

BEBE 15

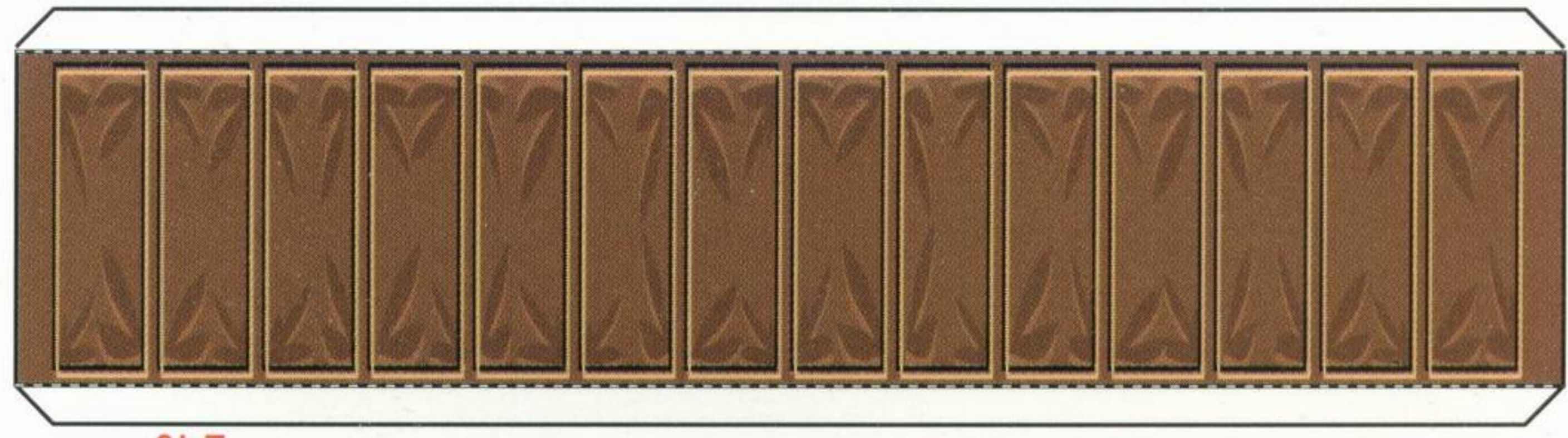
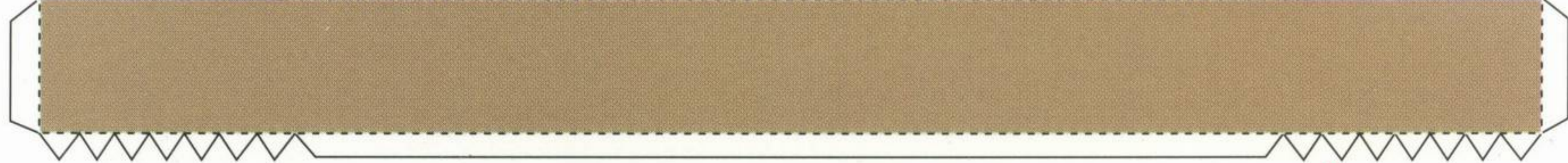
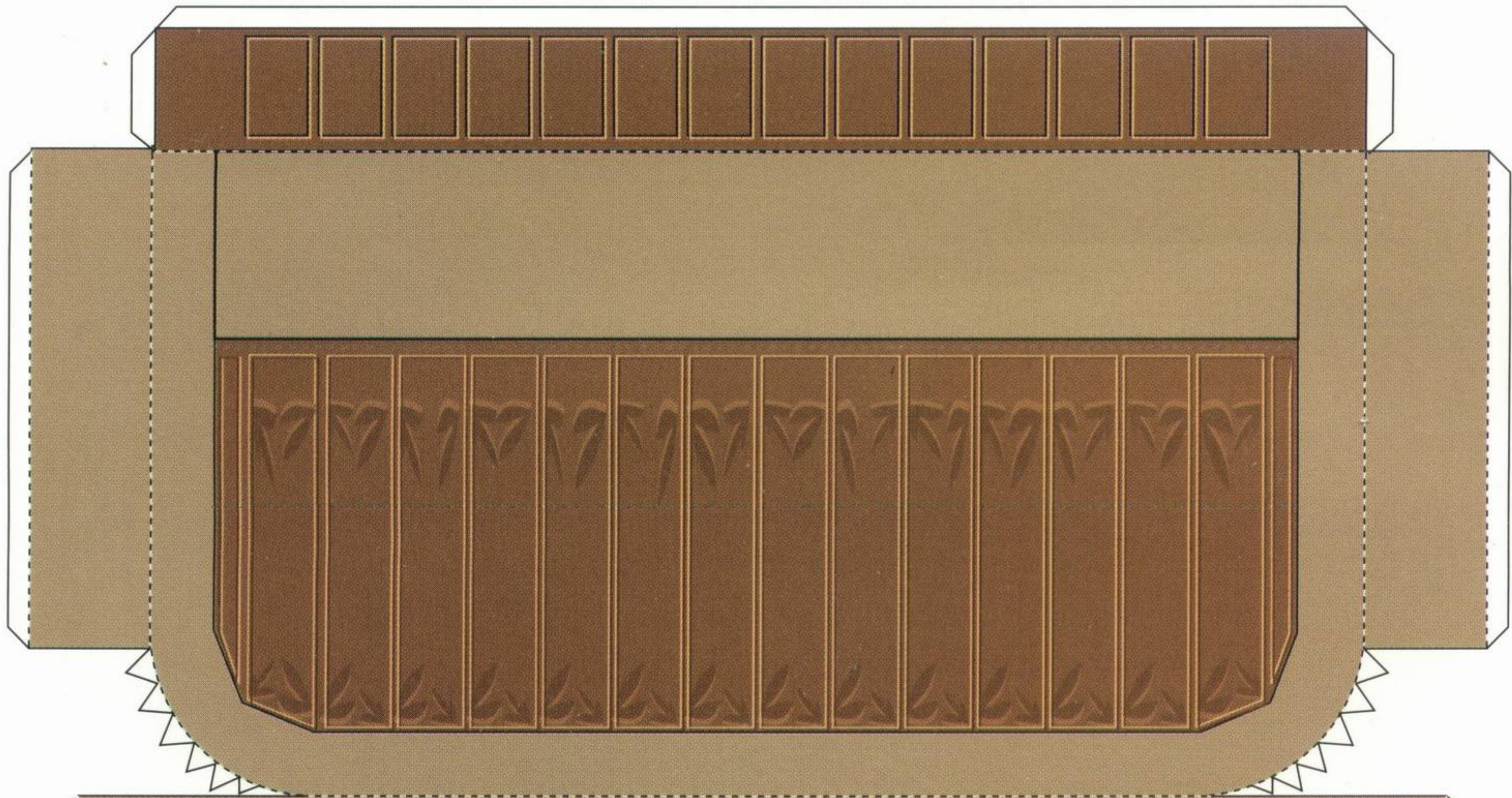

Z-10

Z

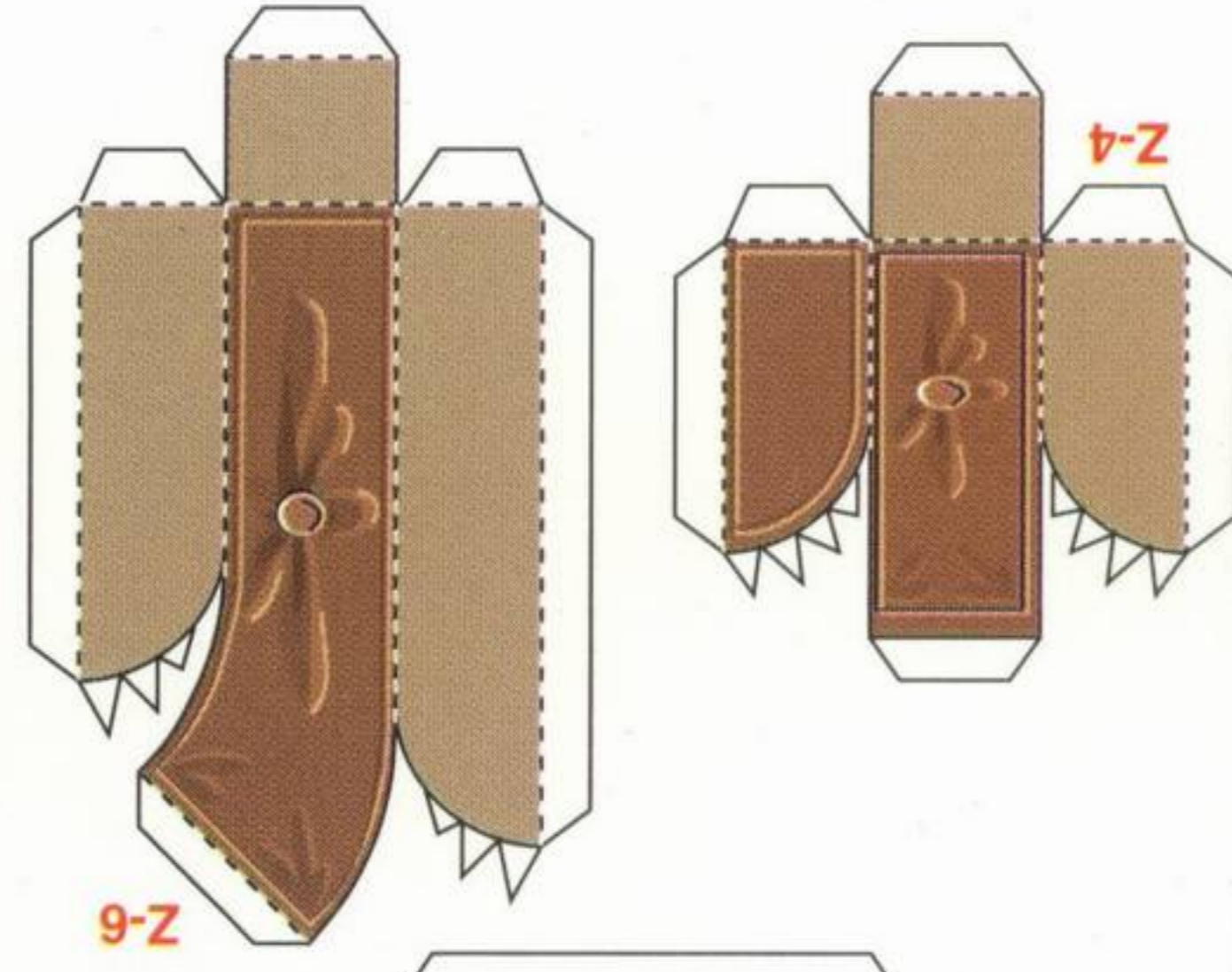

Z-6

Z-4

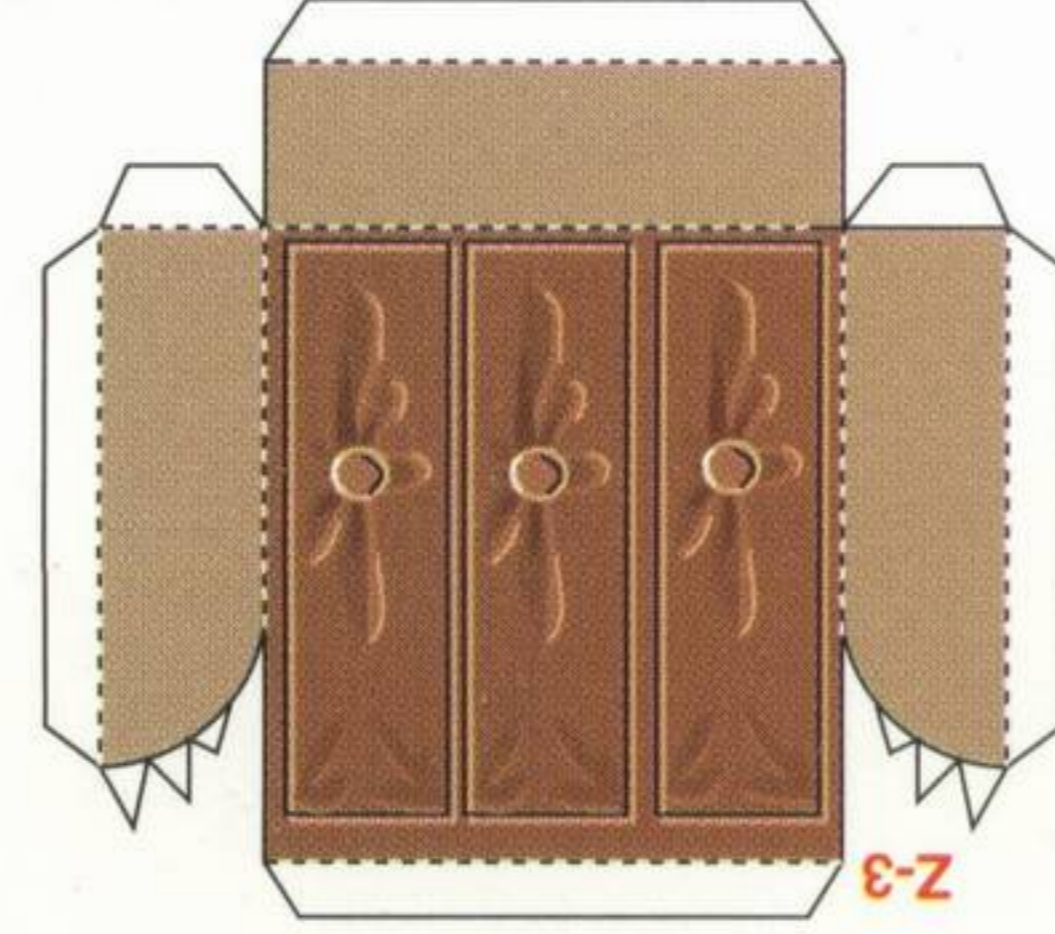

Z-3



Z-5



Z-3

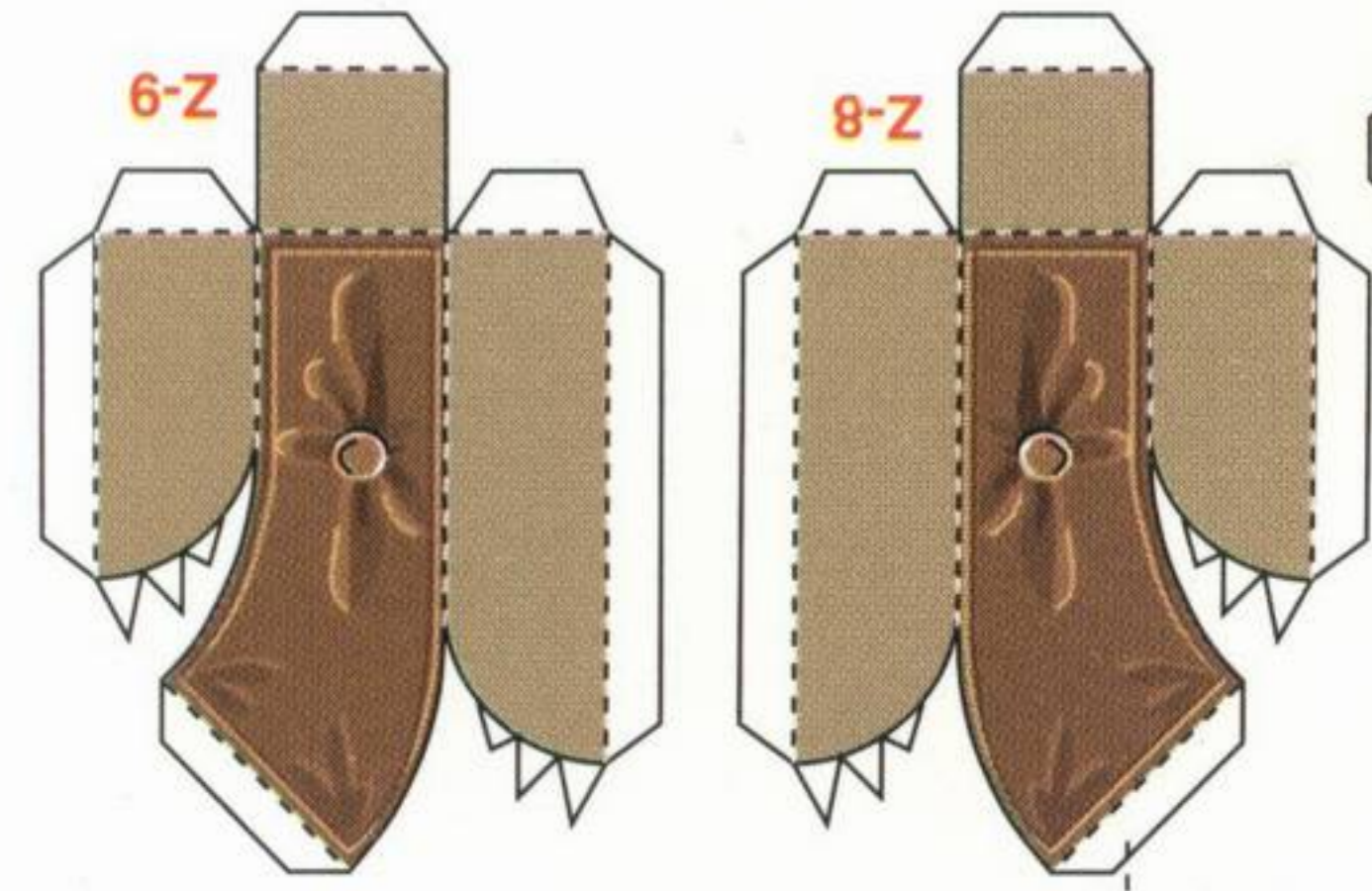

Z-9

Z-8

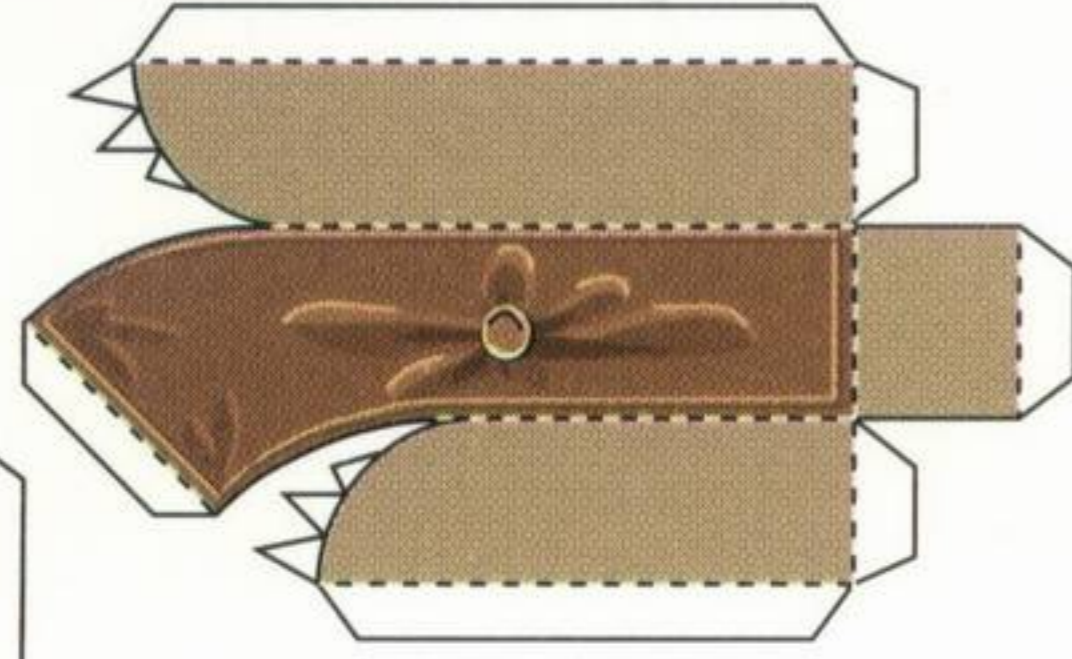

Z-7

PEUGEOT BEBE 1905

6

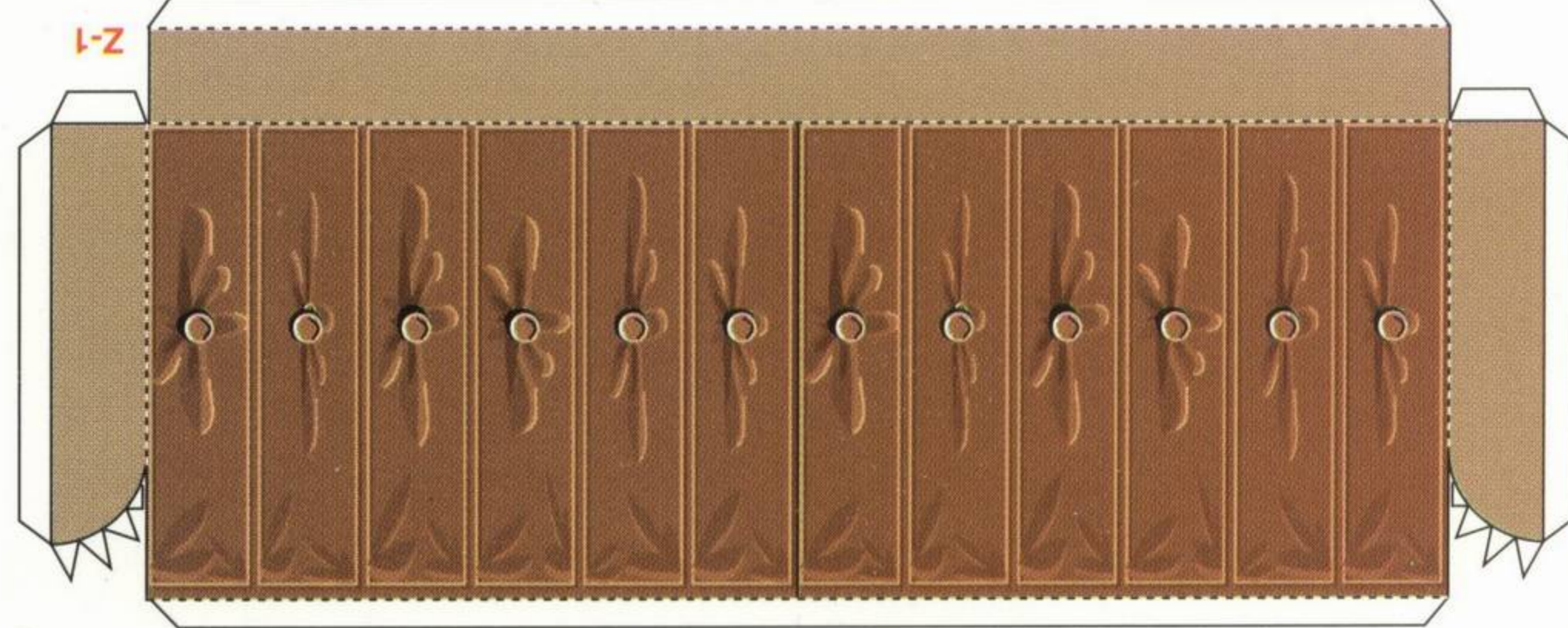

Z-1

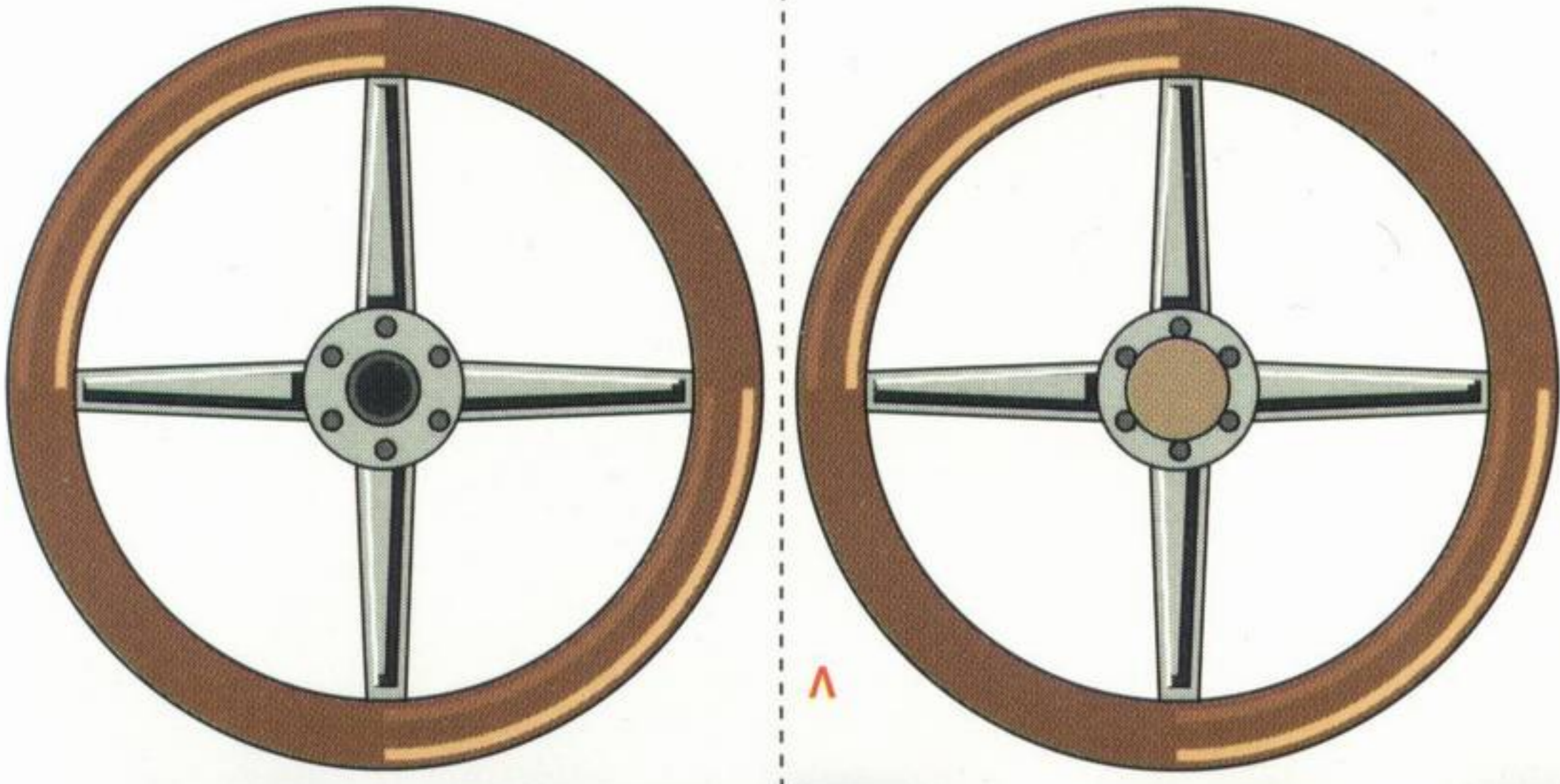

V

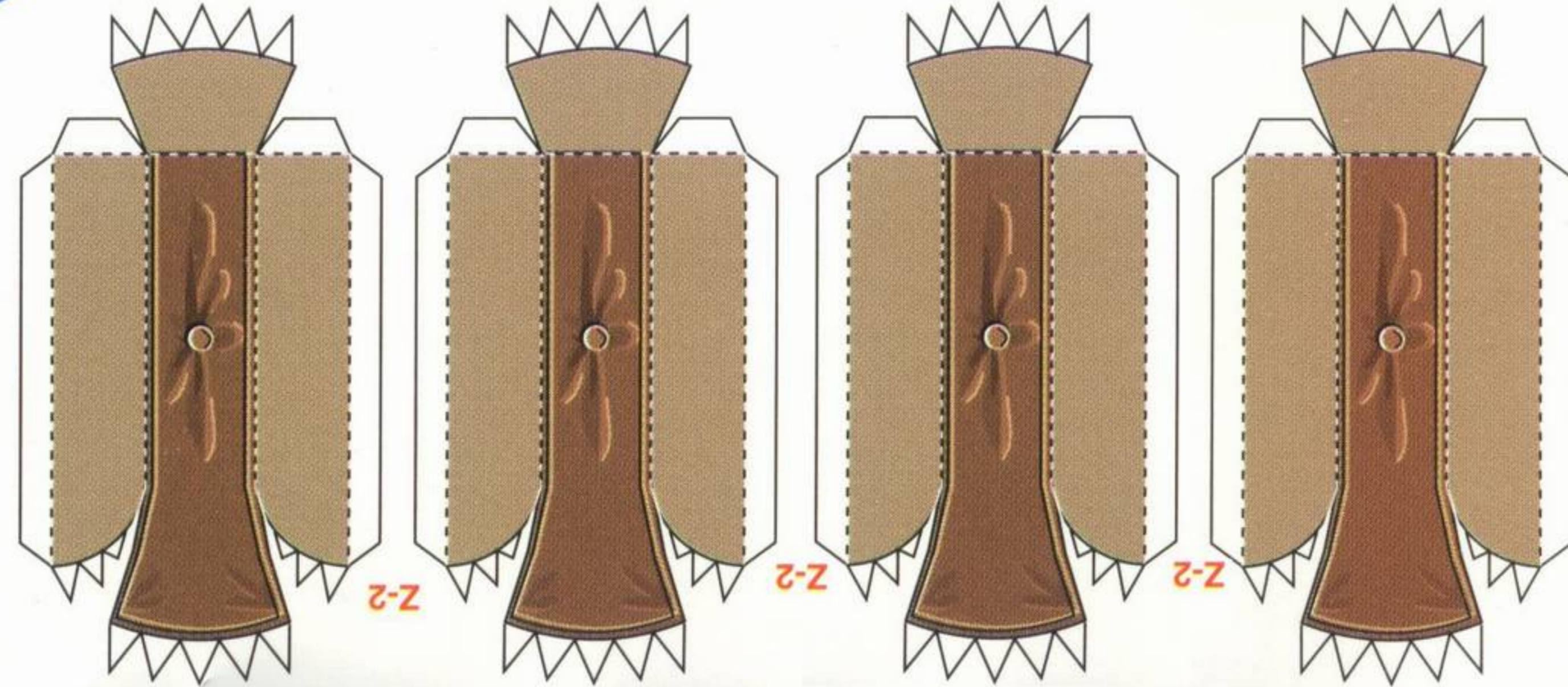

Z-2

Z-2

Z-2

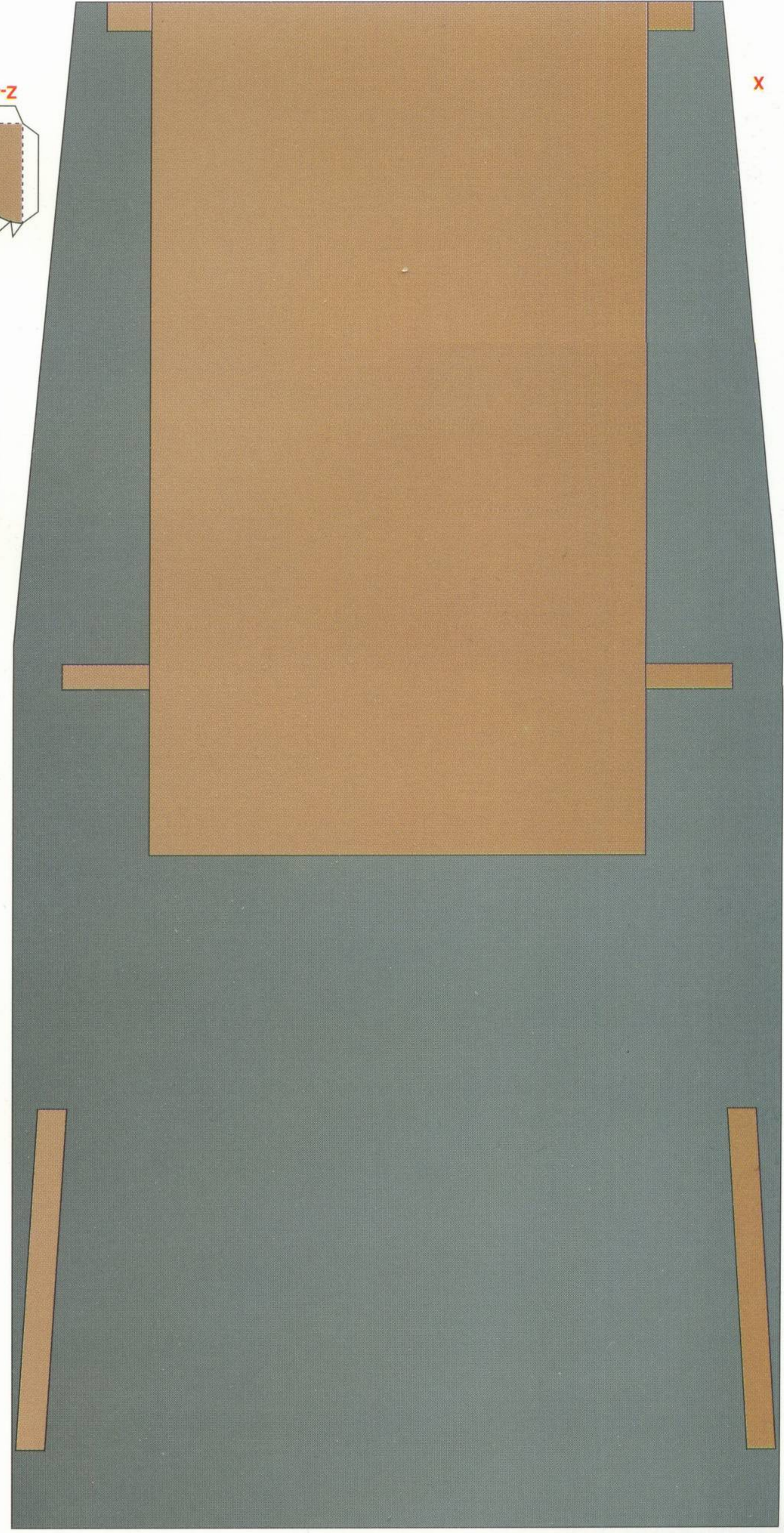

X

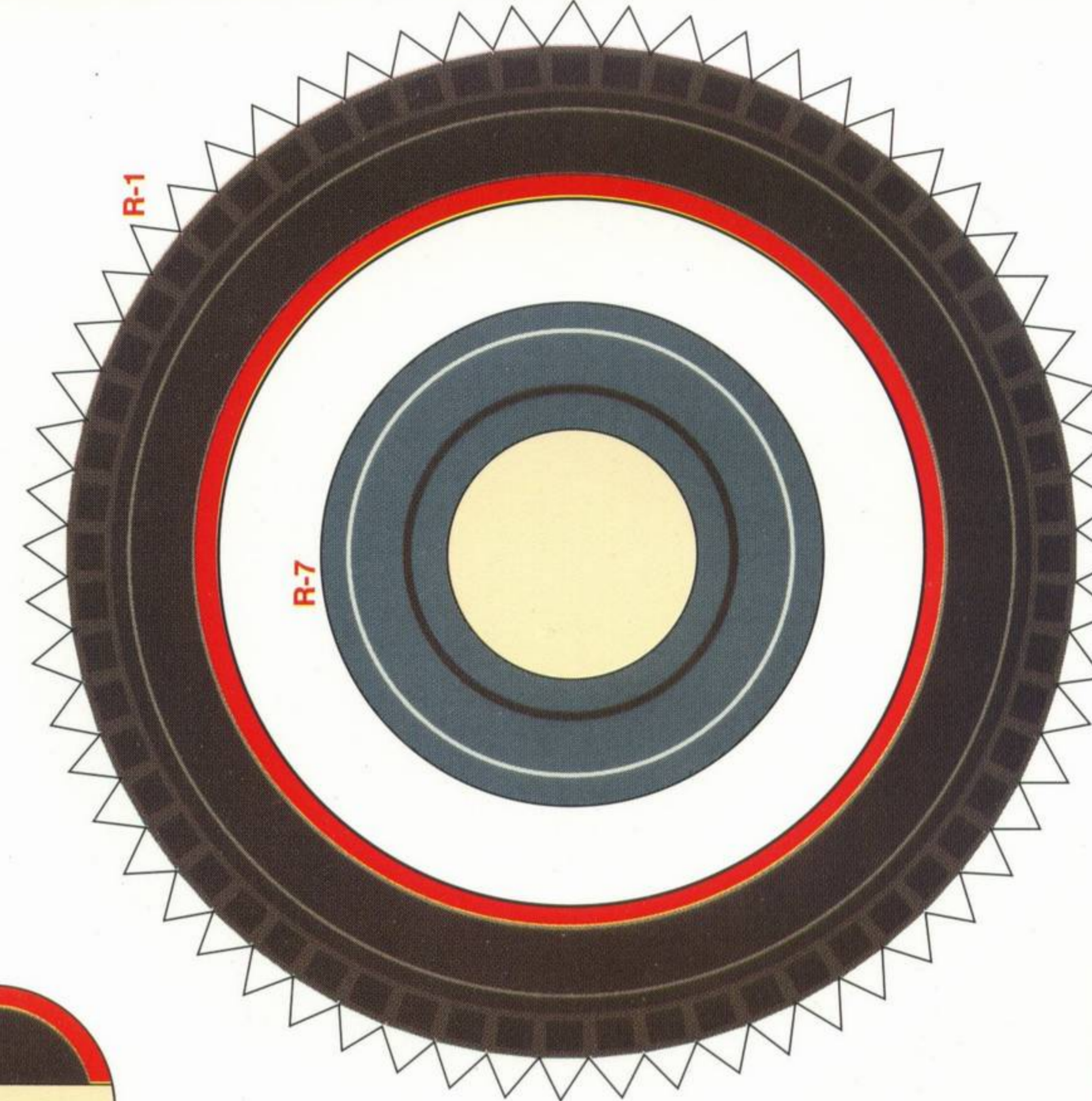
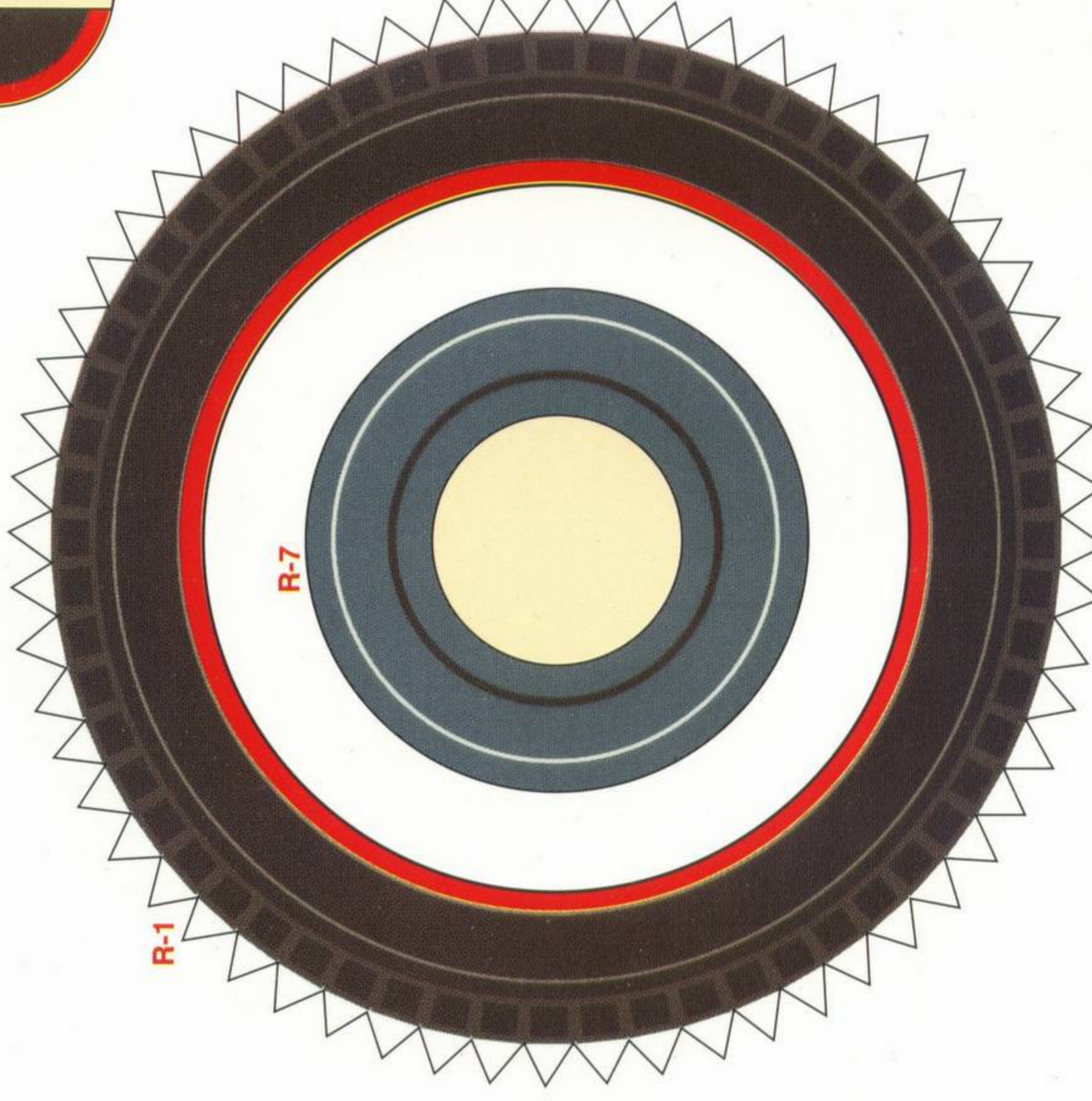
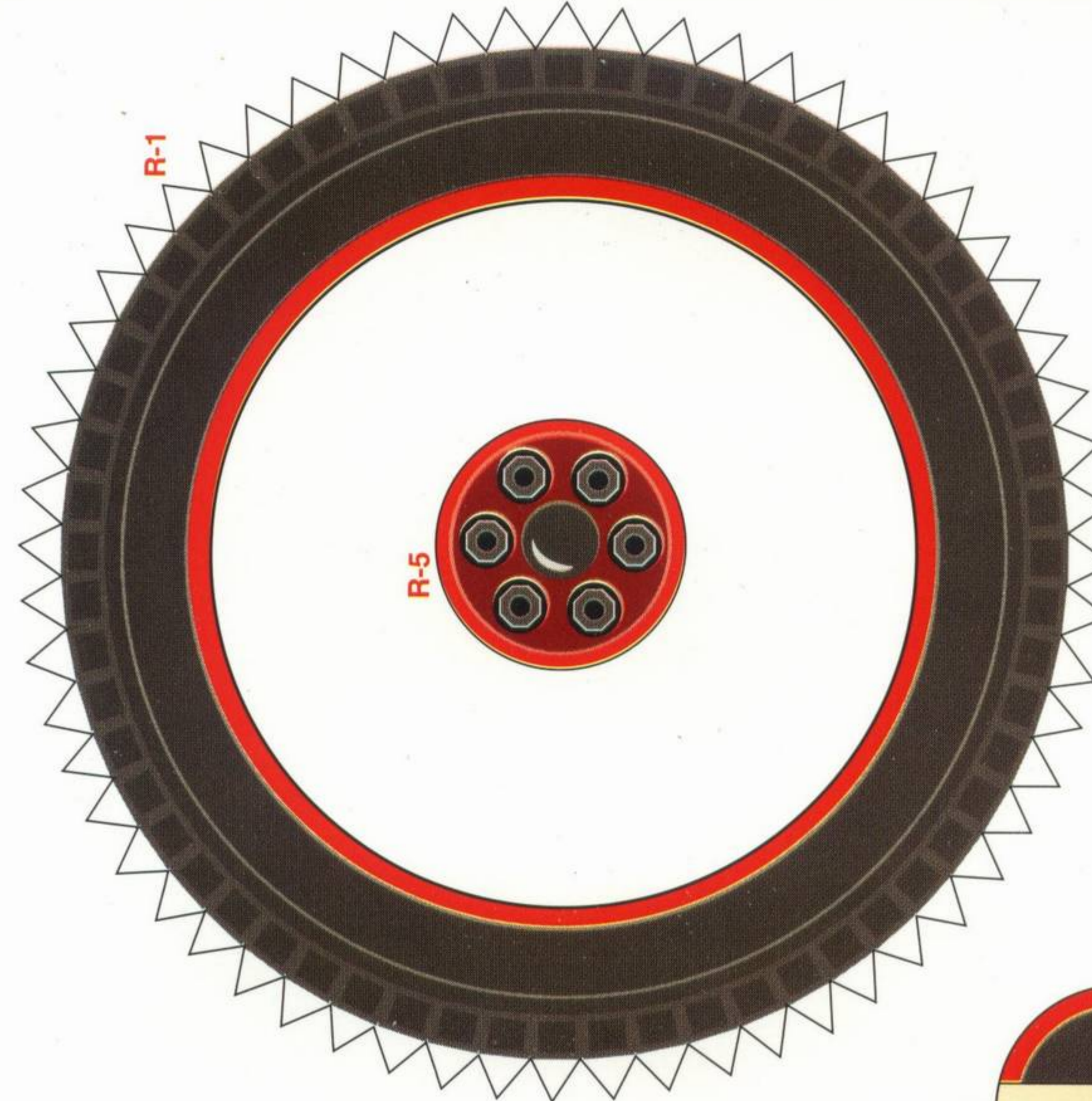
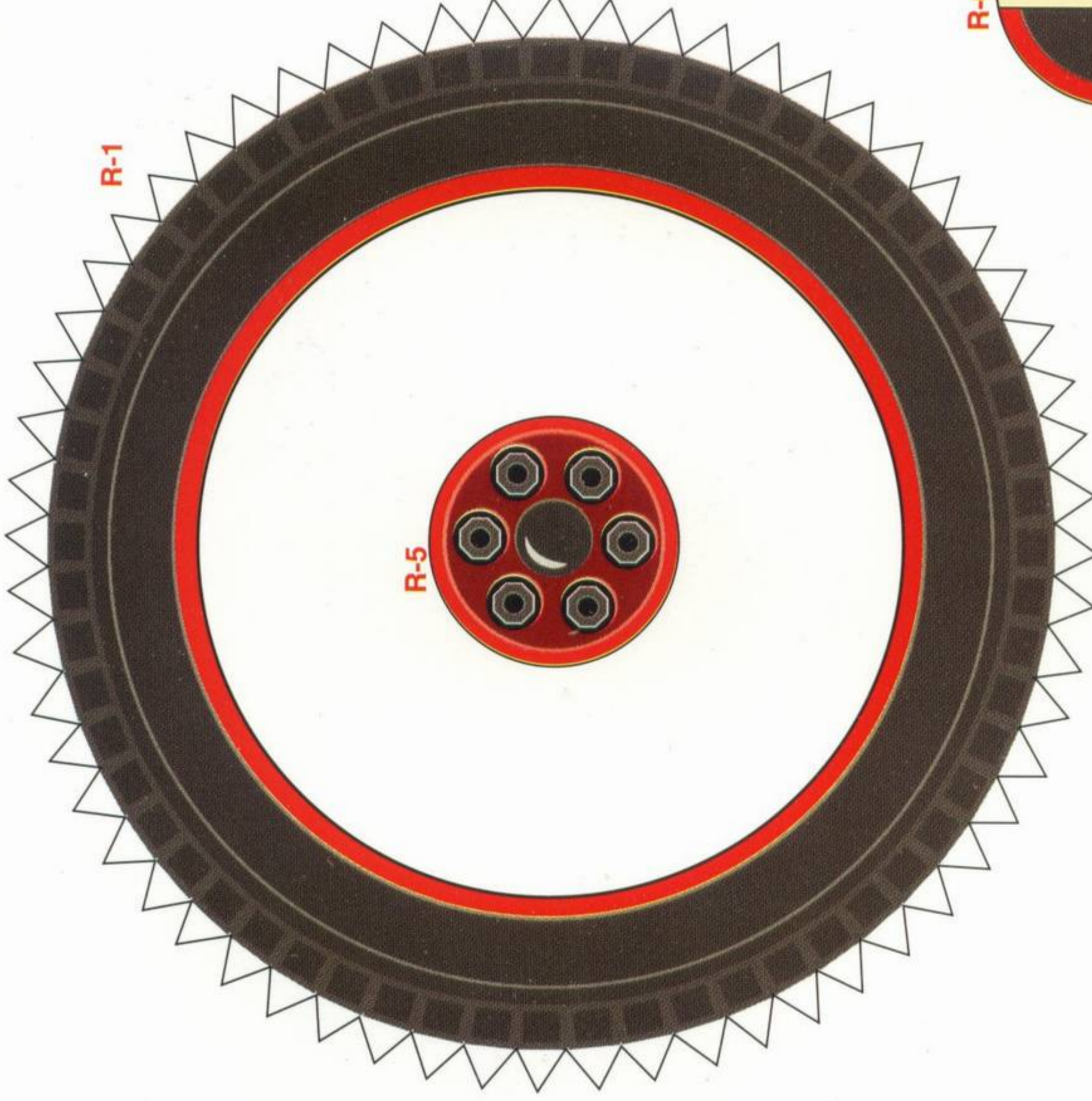
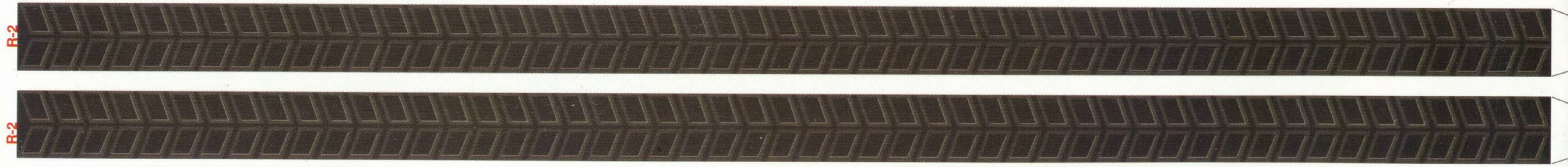

PEUGEOT
BEBE
1905

7

R-10

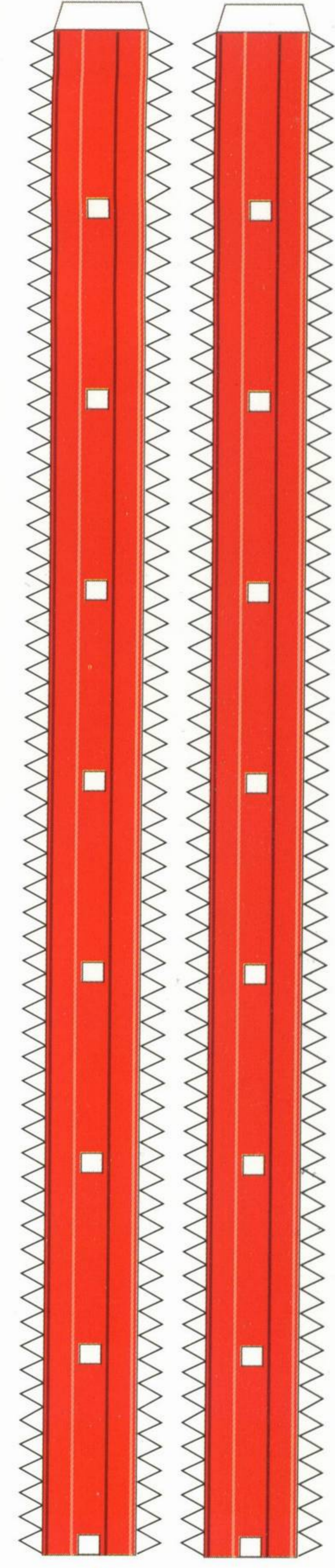
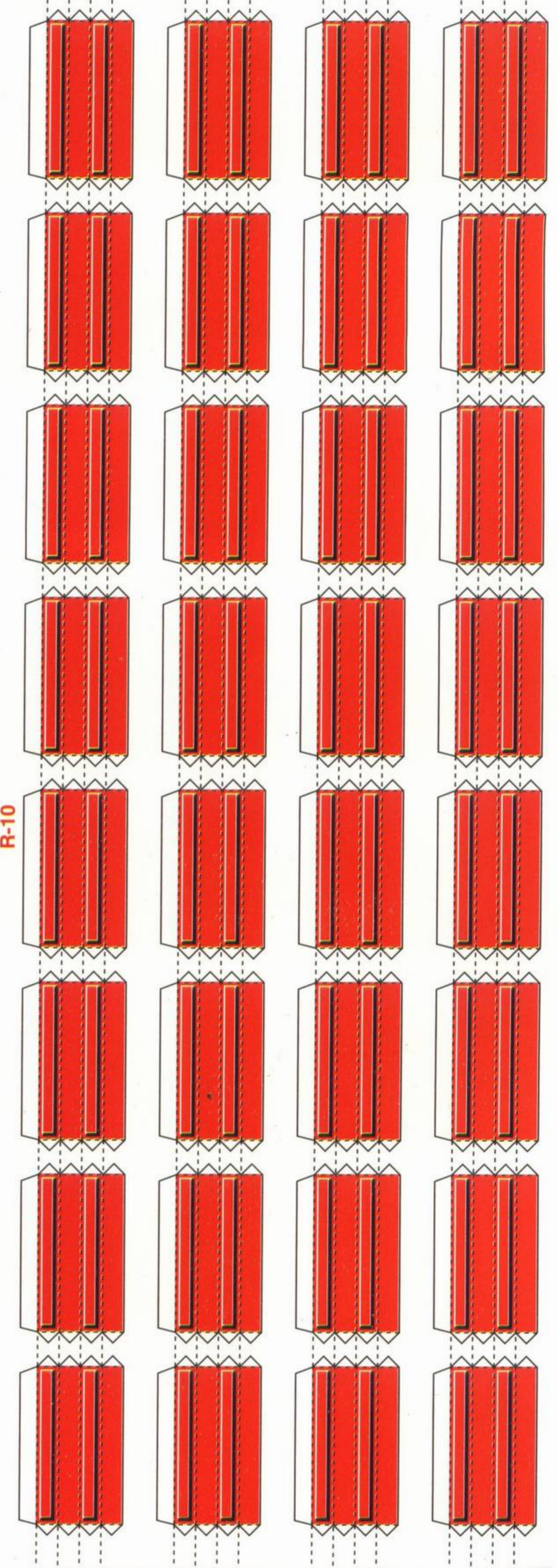

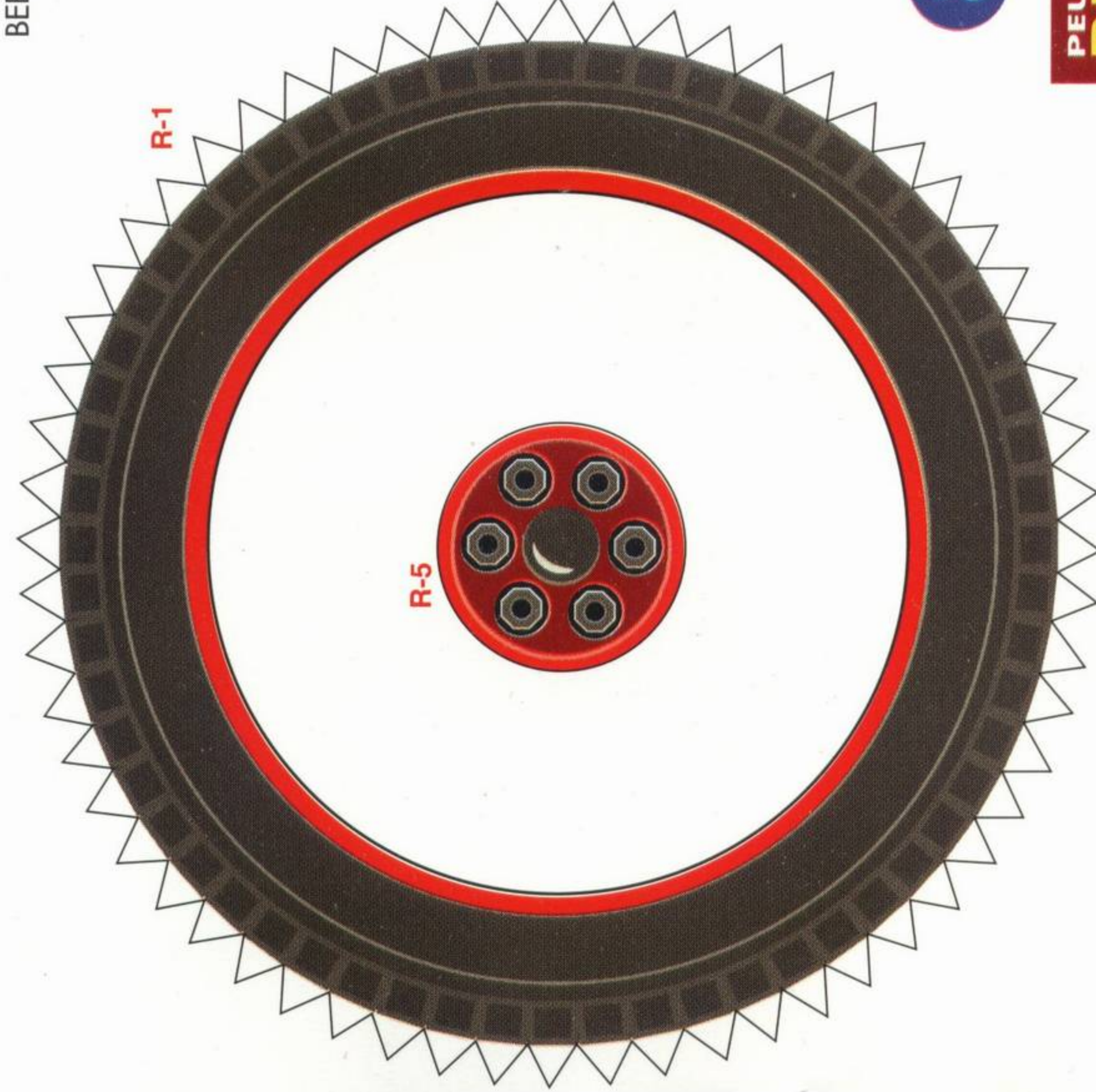
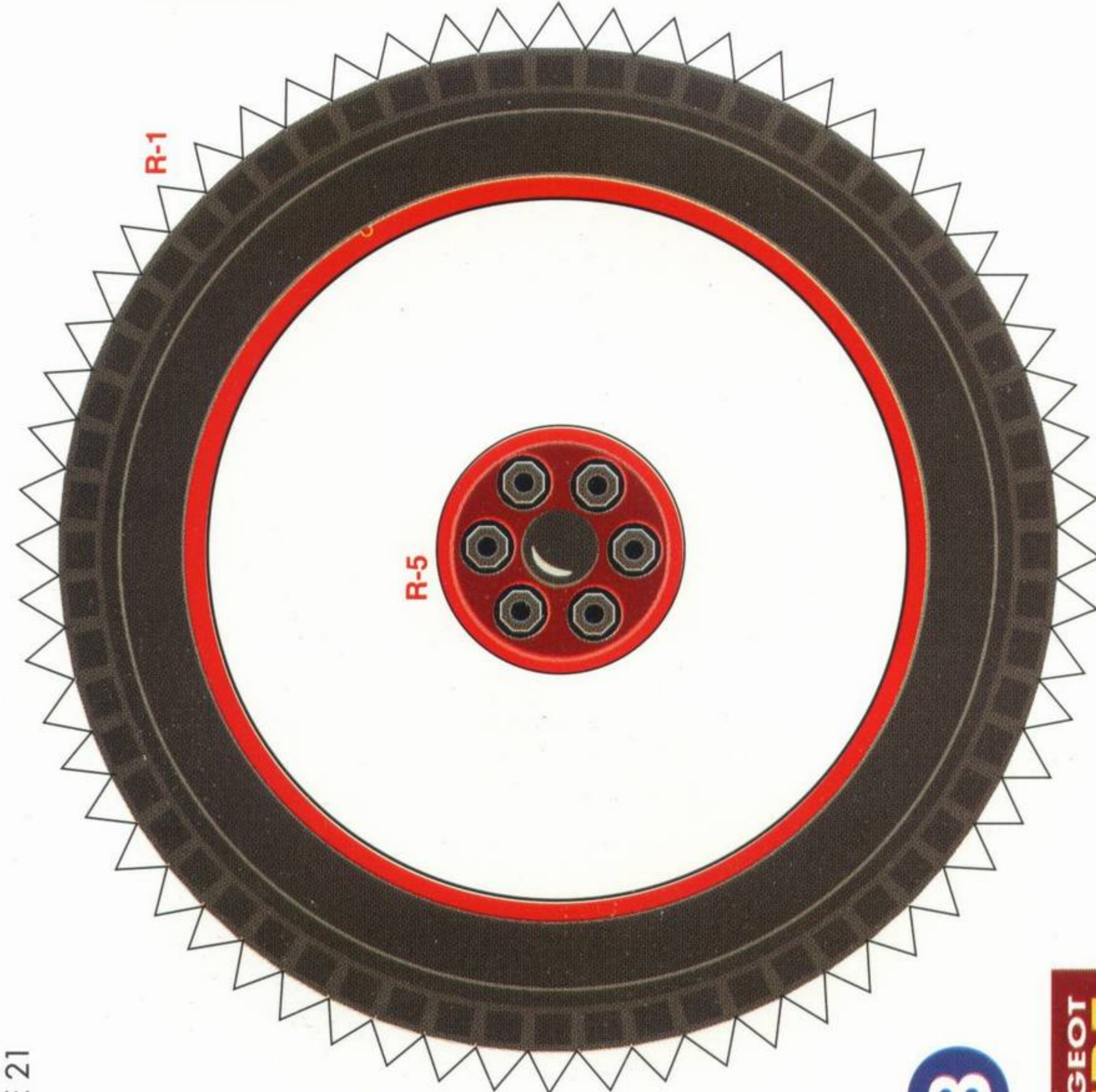

8

PEUGEOT
BEBE
1905

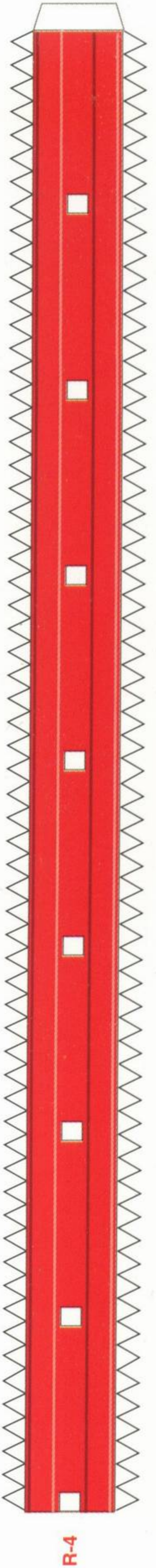
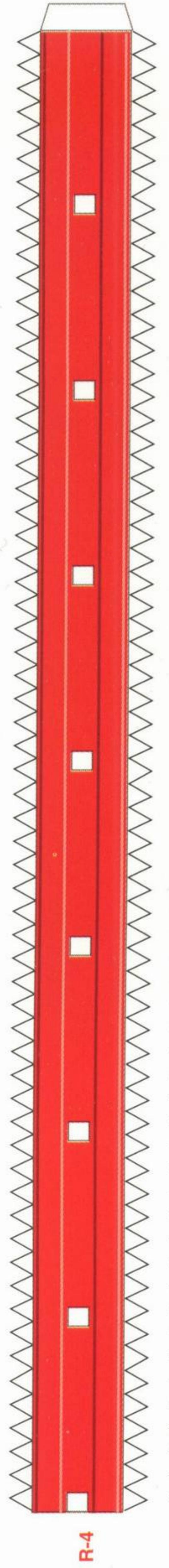
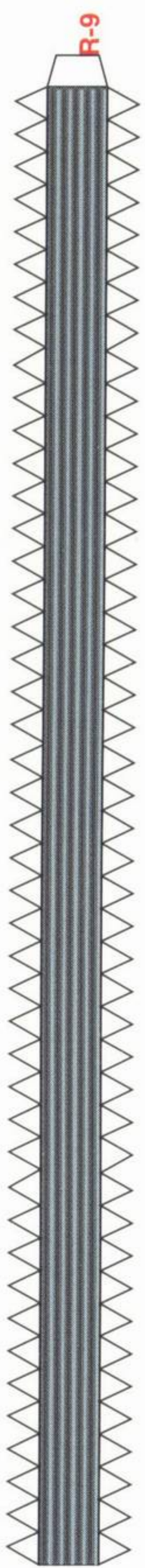
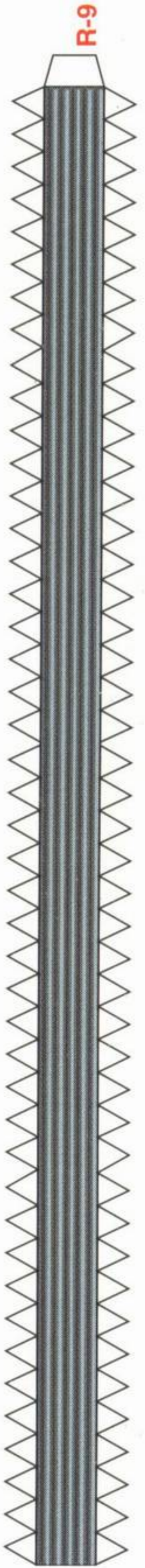
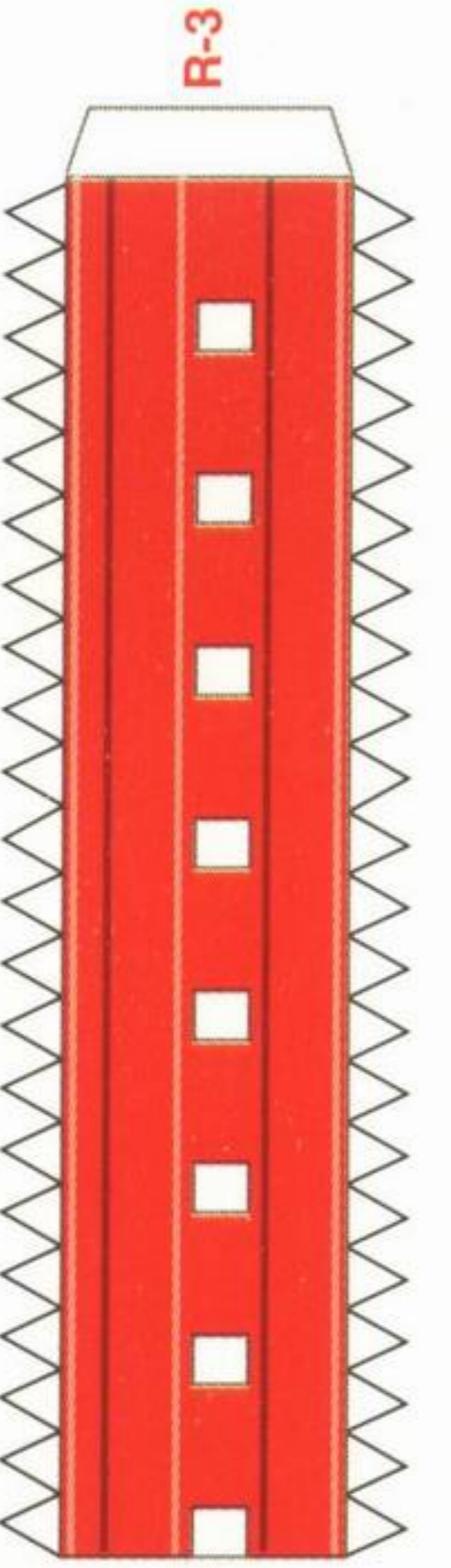
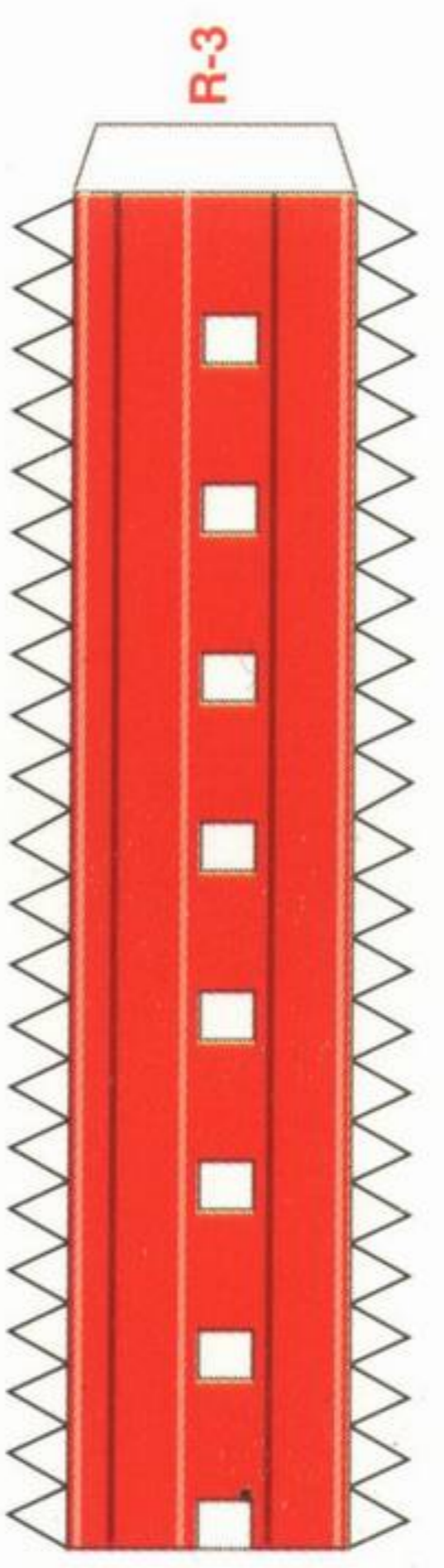
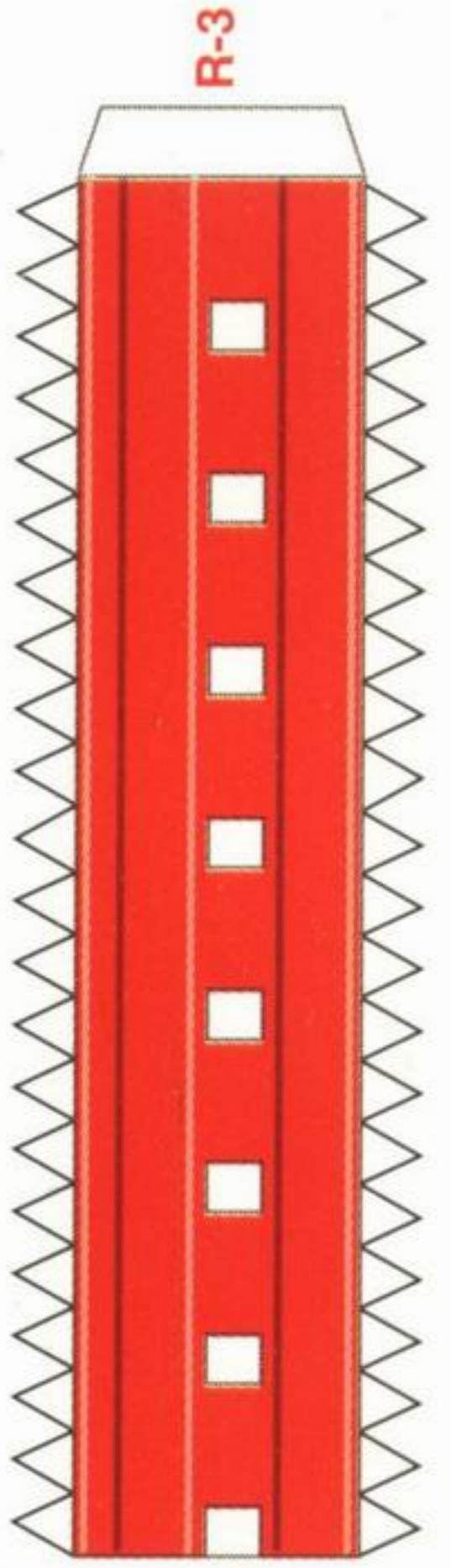
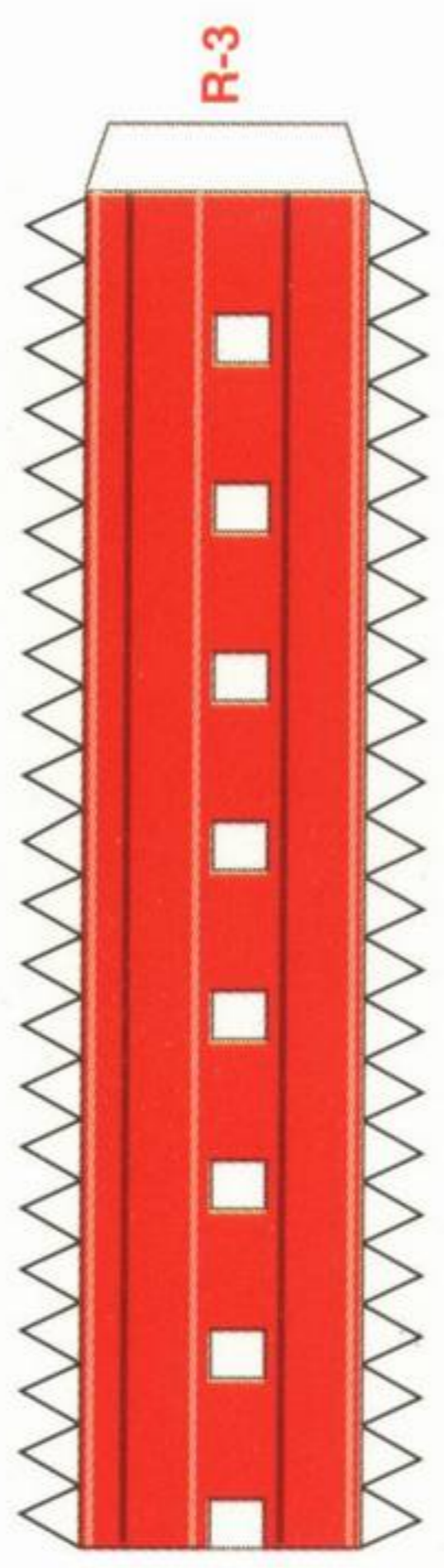
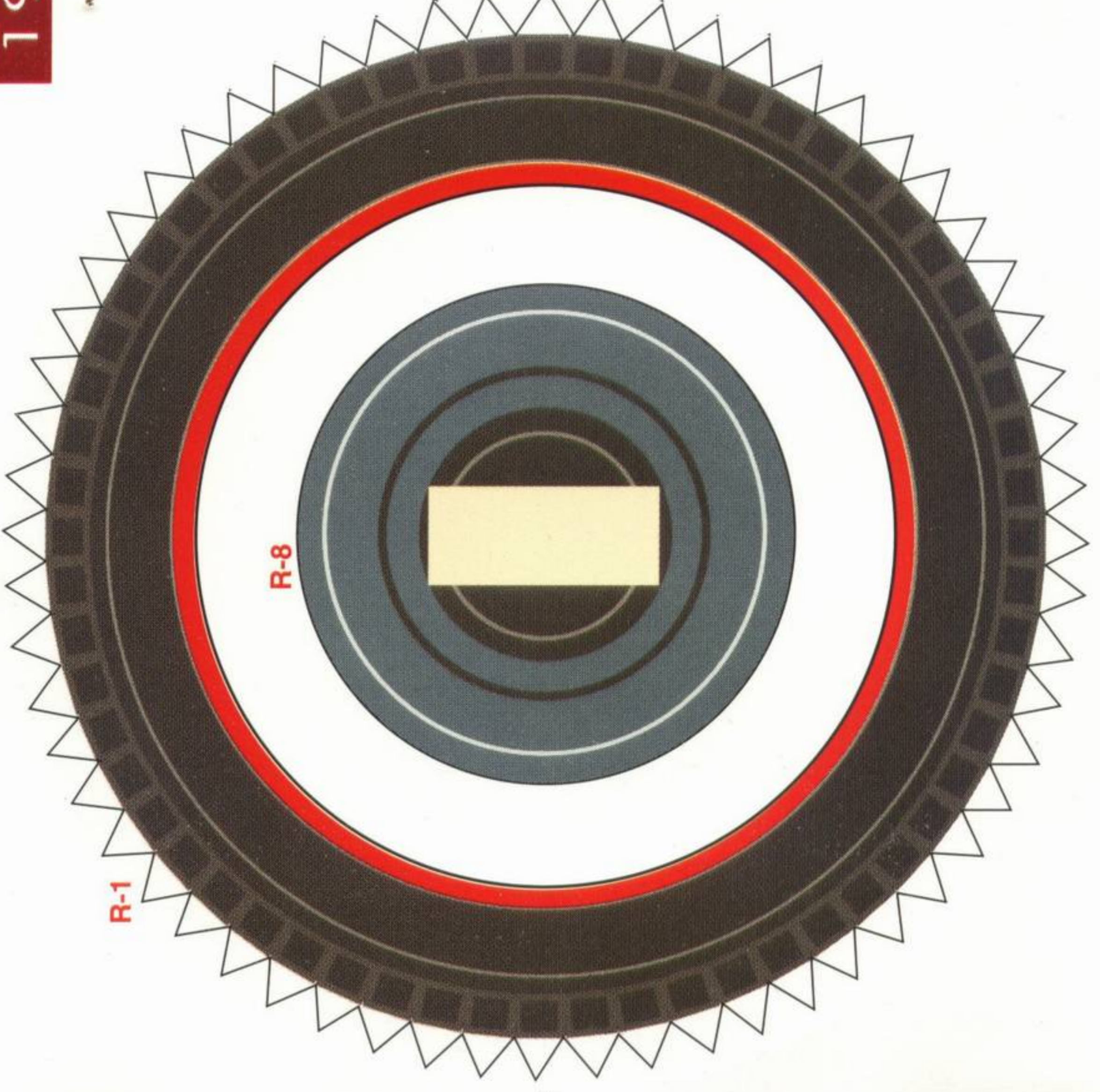
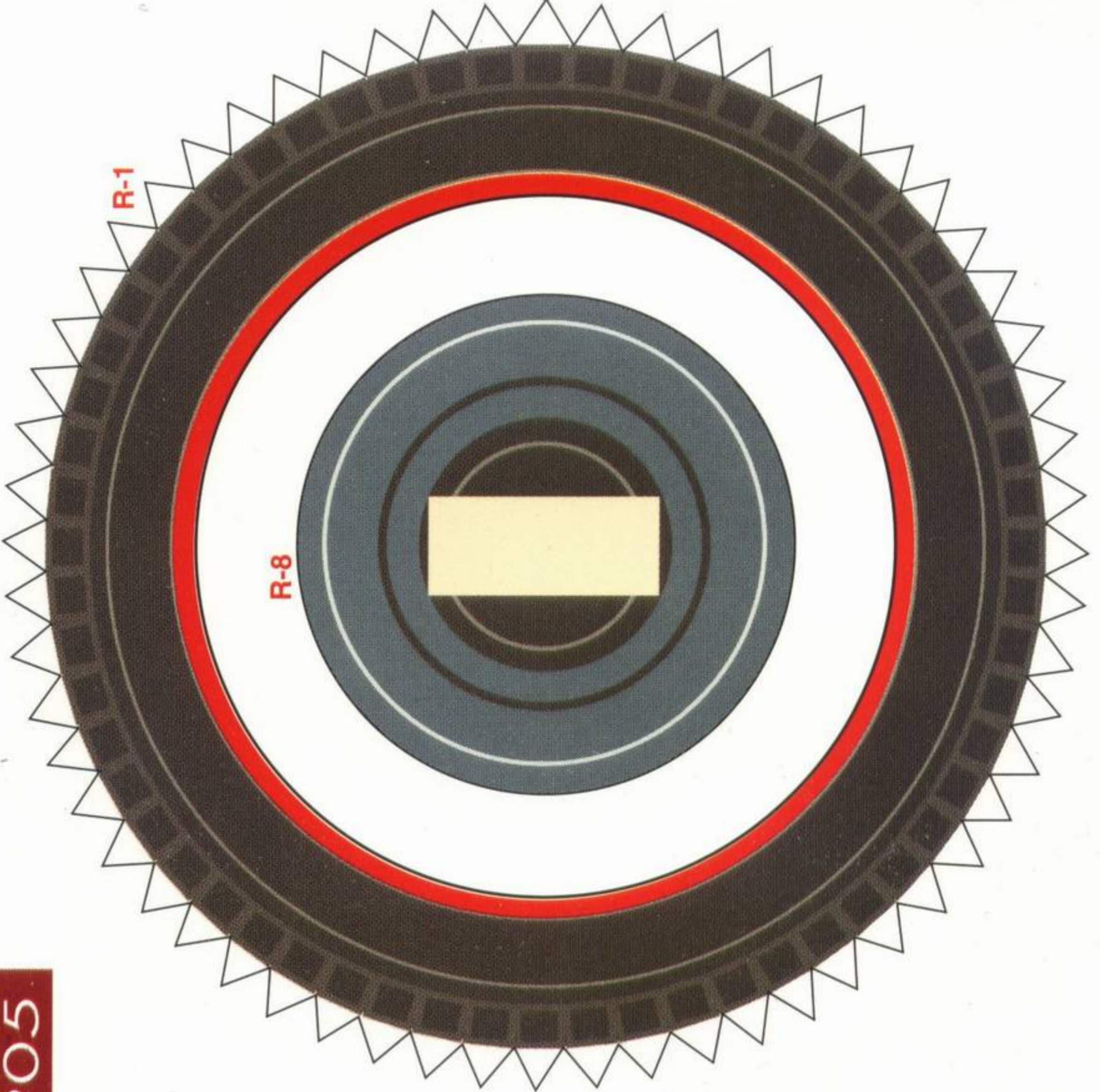

PEUGEOT
BEBE
1905

9

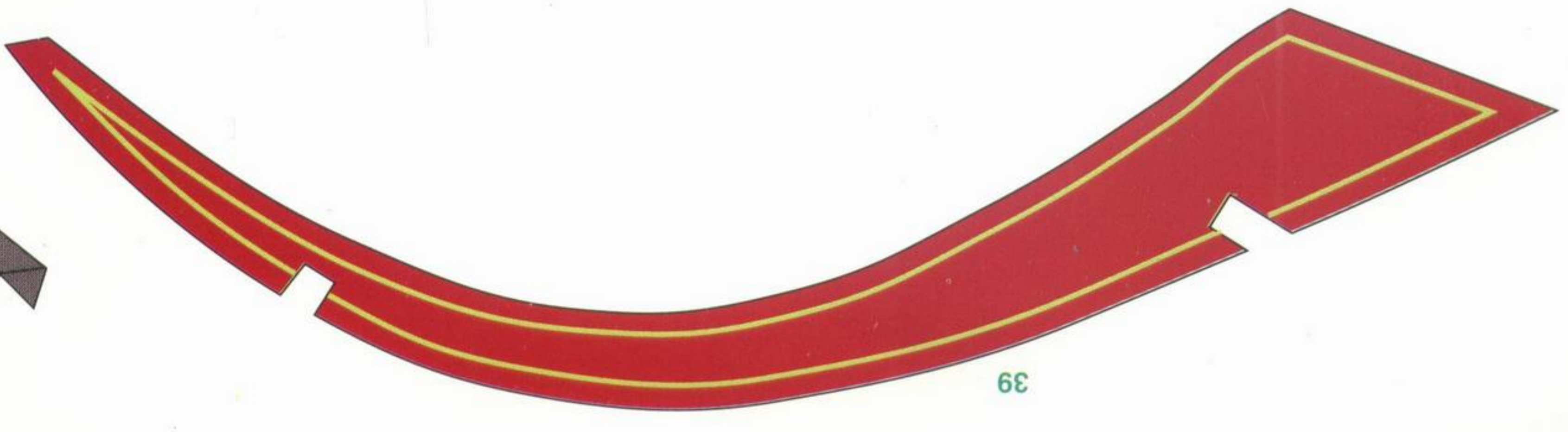
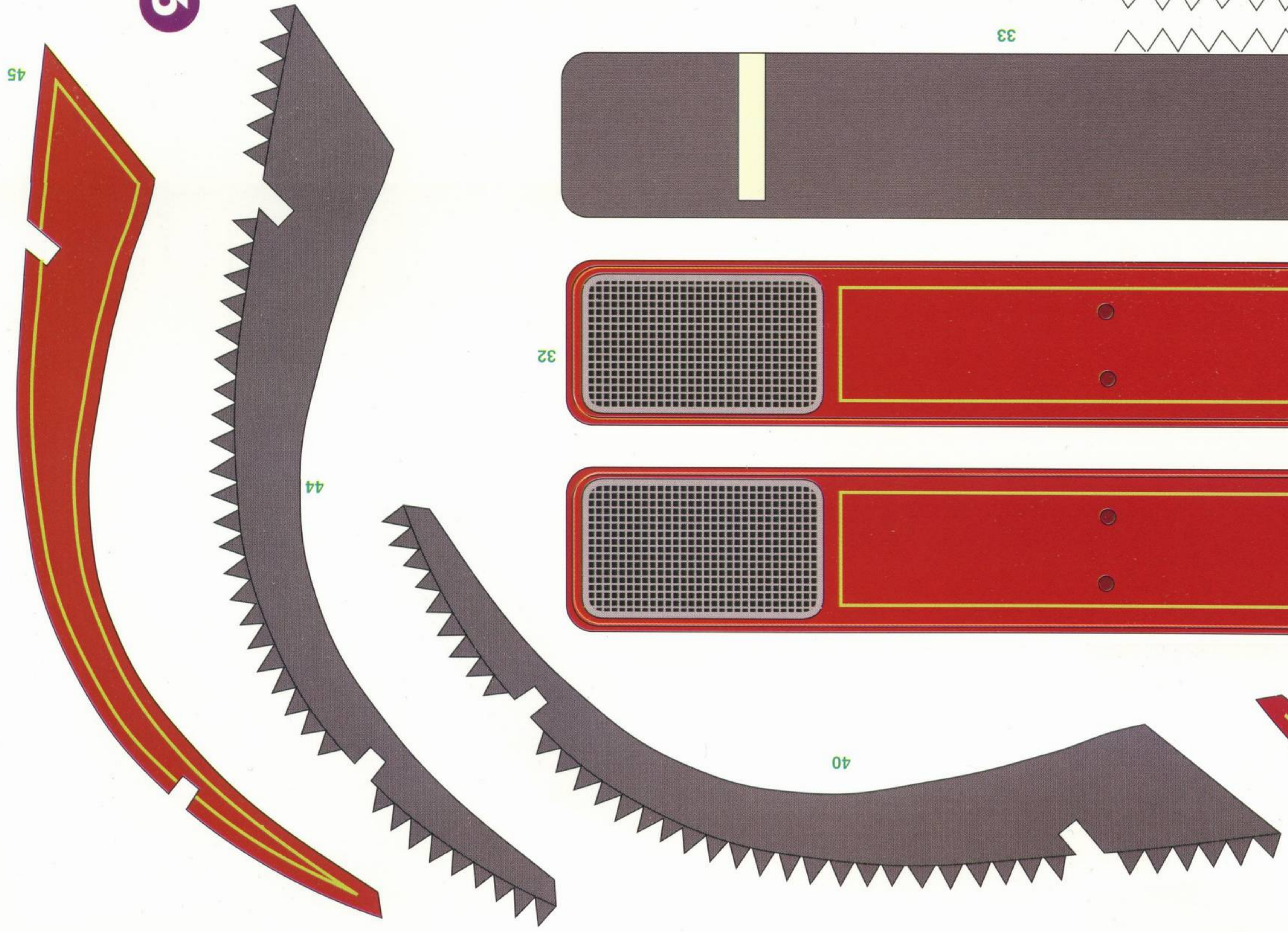
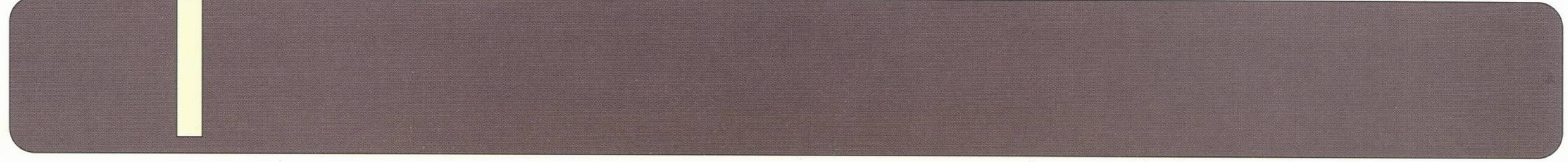
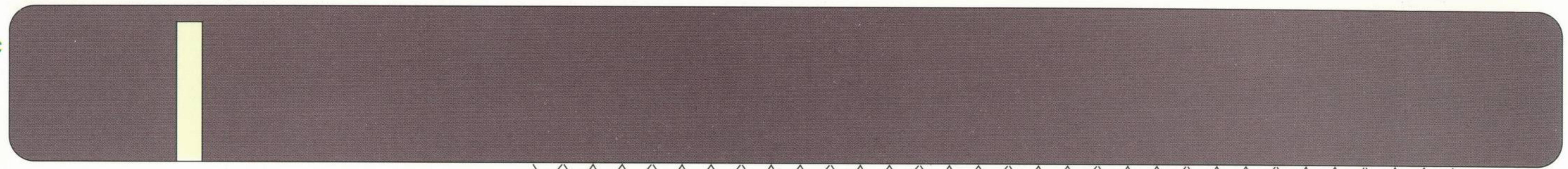
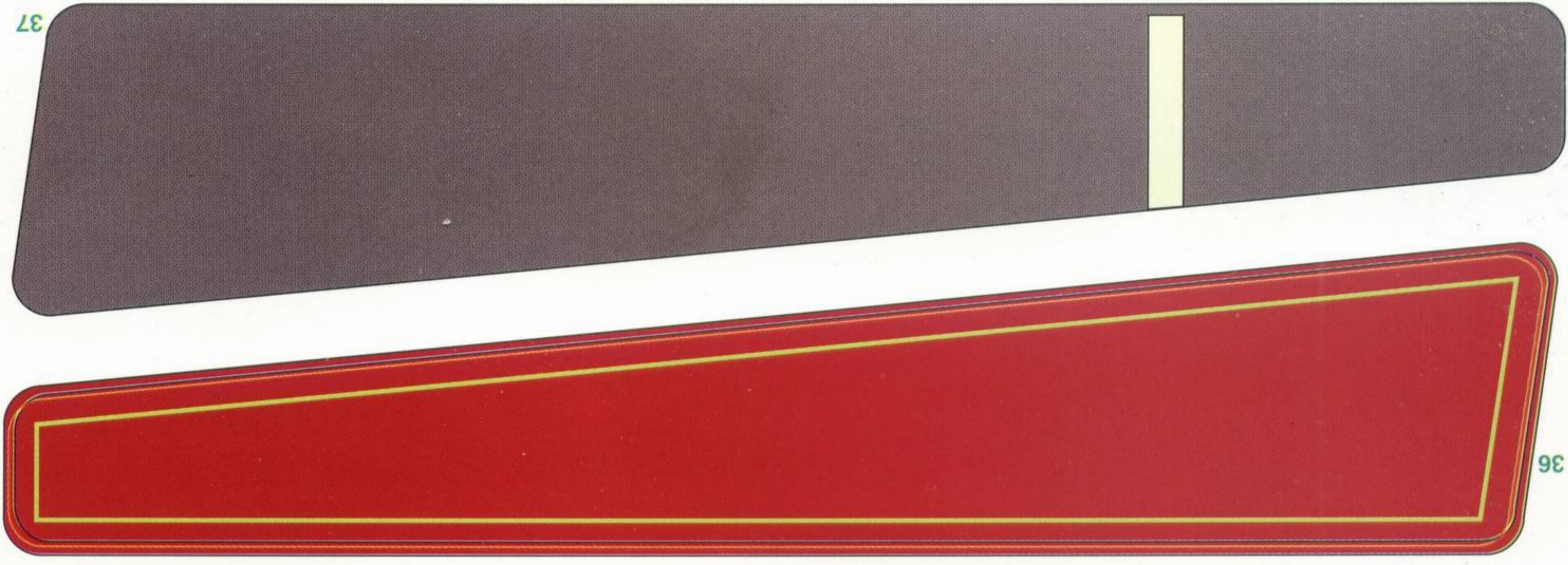
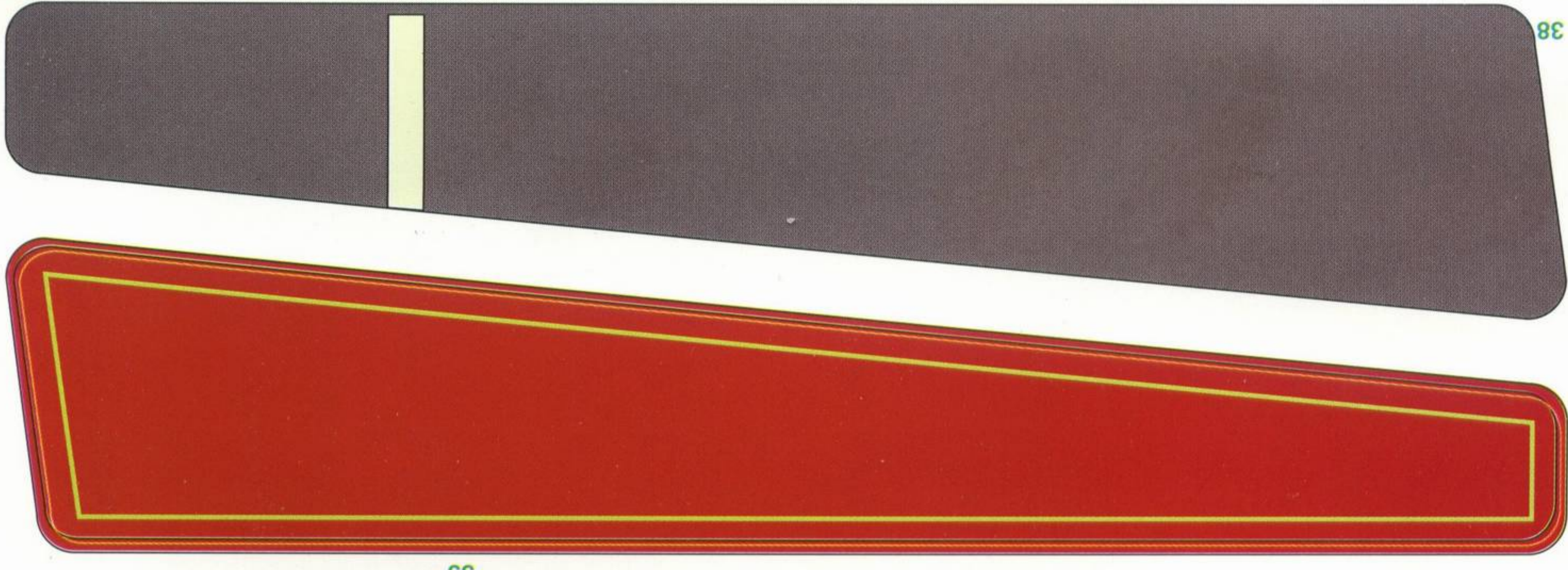

BEBE 23

45

35

38

37

36

34

33

32

31

40

39