

Racing Trucks

J&C-Alcan - Racing Team



Racing Trucks

Design by Alcan

1:24



MAQUETA
PAPEL / PAPER
SCALE MODEL

KIT
Recortable
Cutout
Découpable
Ausschneidbar
Ritagliabili
Recortável

Contiene 6 hojas/68 piezas
Contains 6 sheets/68 pieces
Contient 6 feuilles/68 pièces

Enthält 6 zubehörblätter/68 Teile
Contiene 6 fogli/68 pezzi
Contém 6 folhas/68 peças



c.a. gráfica



c.a. gráfica

ALCAN



ALCAN



c.a. gráfica



c.a. gráfica

ALCAN



ALCAN



ALCAN



J&C

J&C

J&C

J&C

RACING TRUCK



Racing Truck

1:24



Racing Truck

1:24

RACING TRUCK

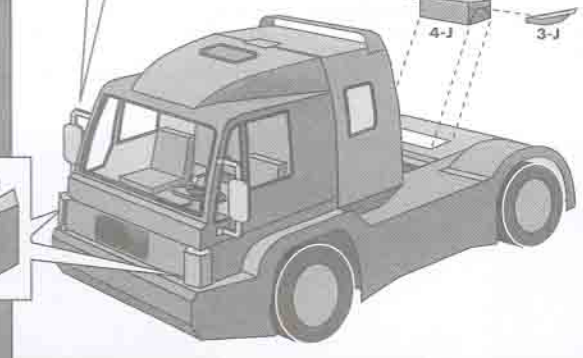
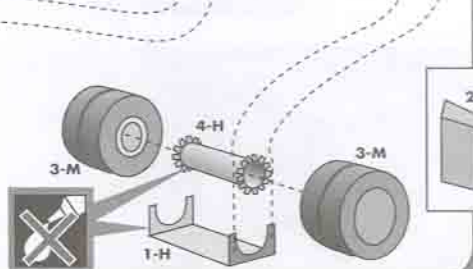
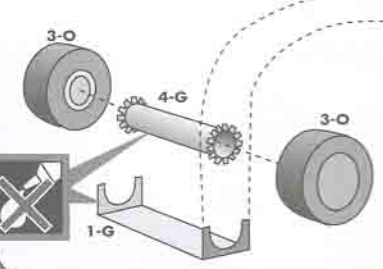
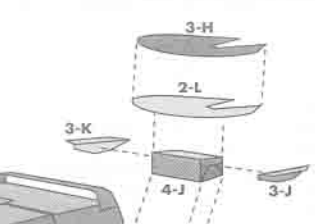
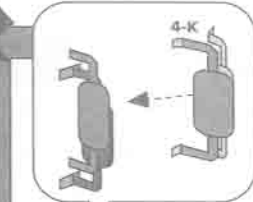
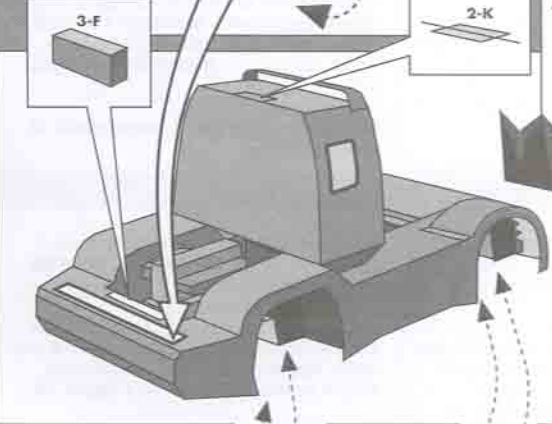
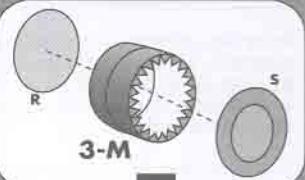
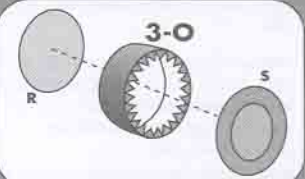
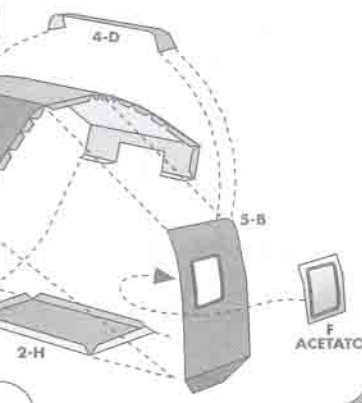
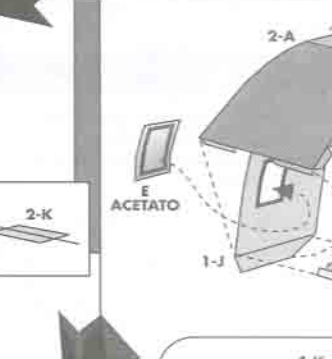
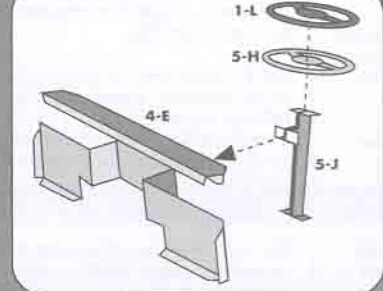
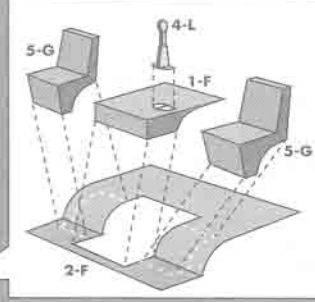
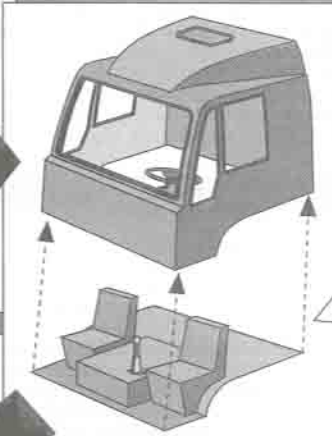
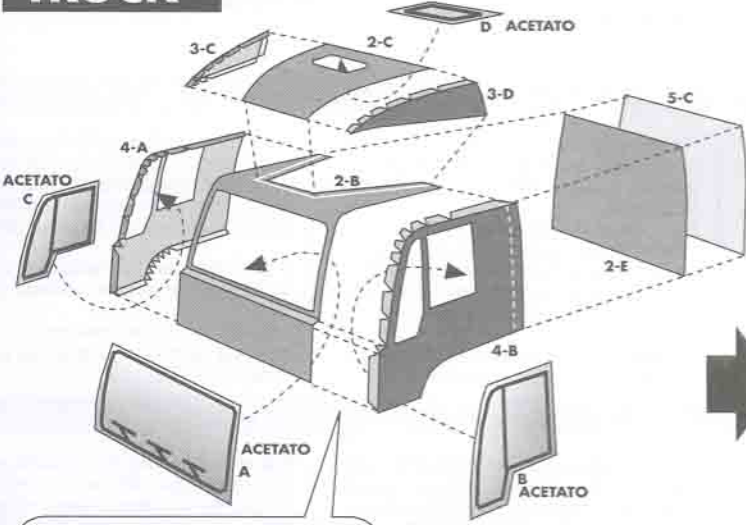
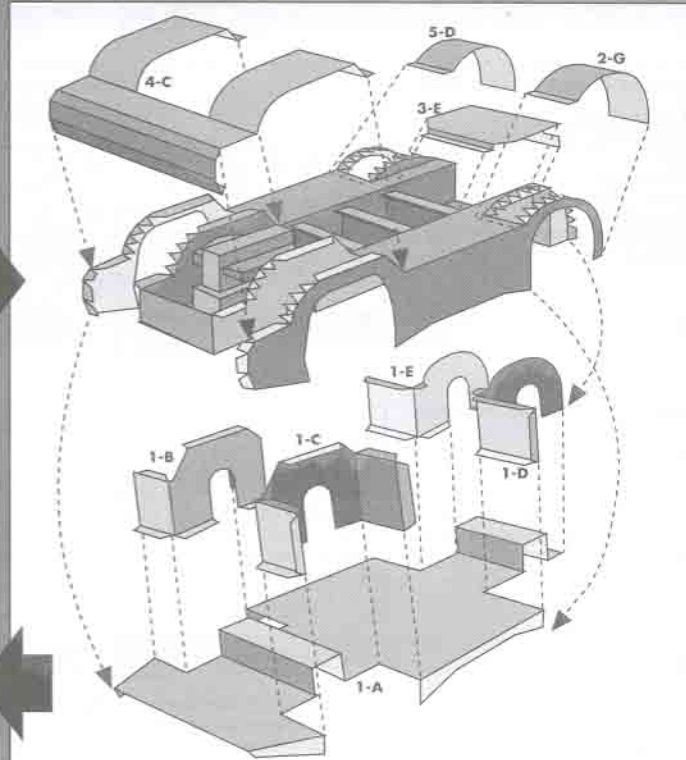
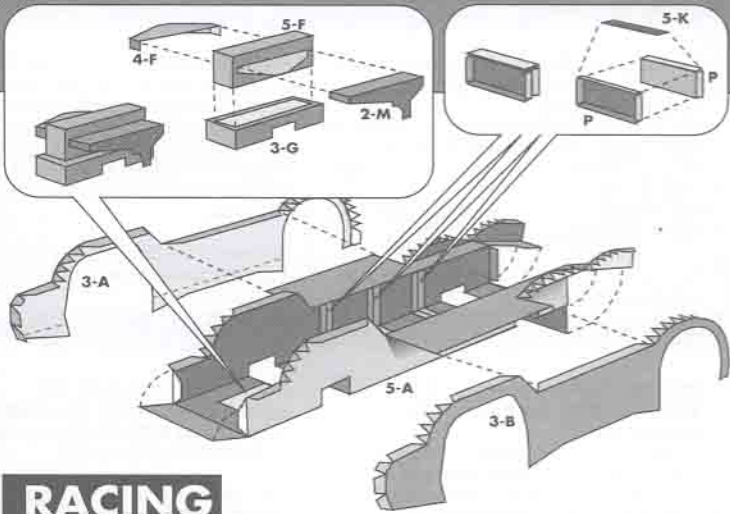

1 RACING TRUCK

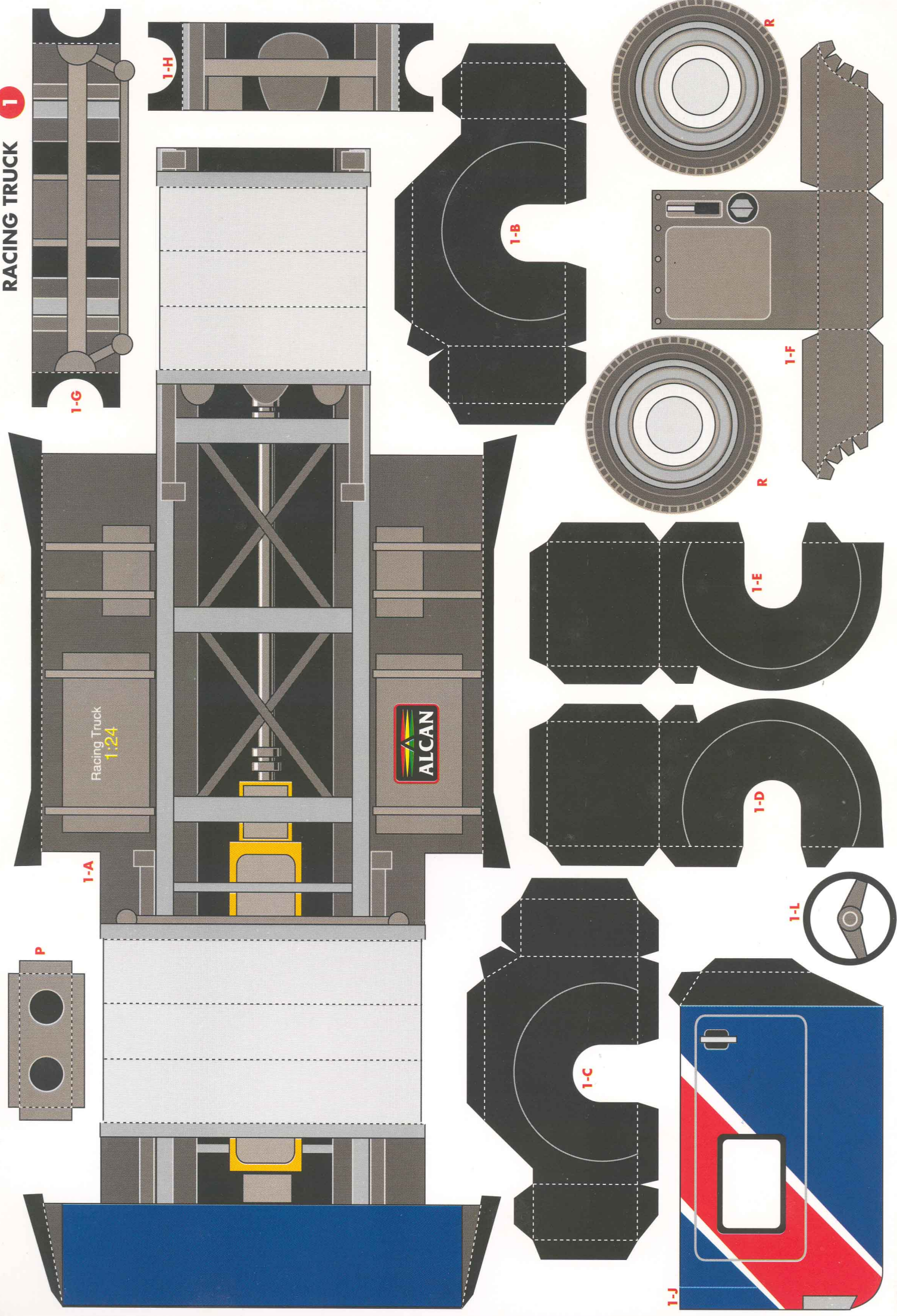

2
RACING TRUCK

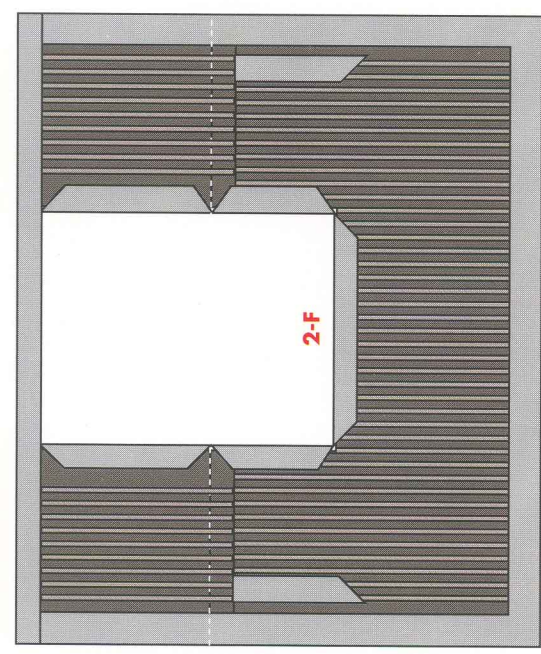

2-F

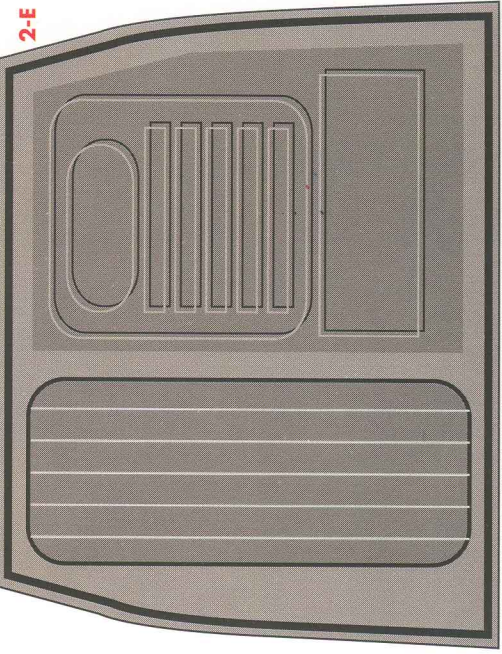
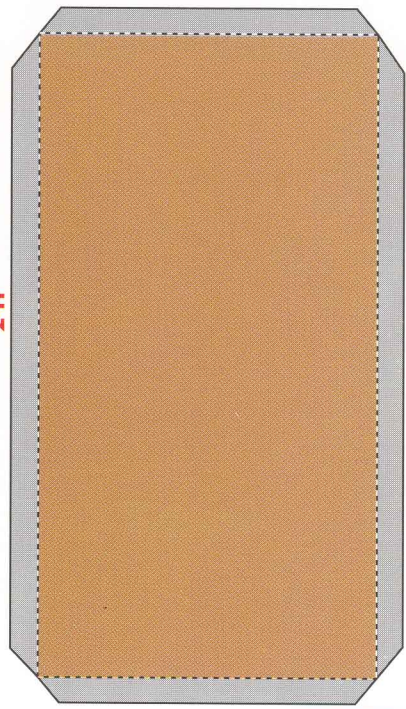

2-H

2-E



2-C

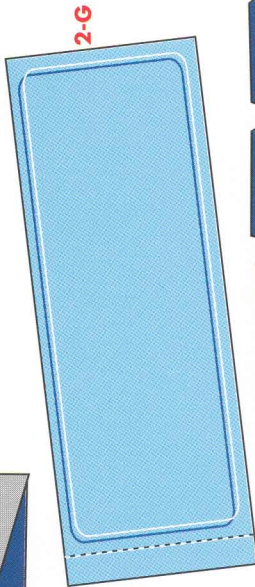

2-G

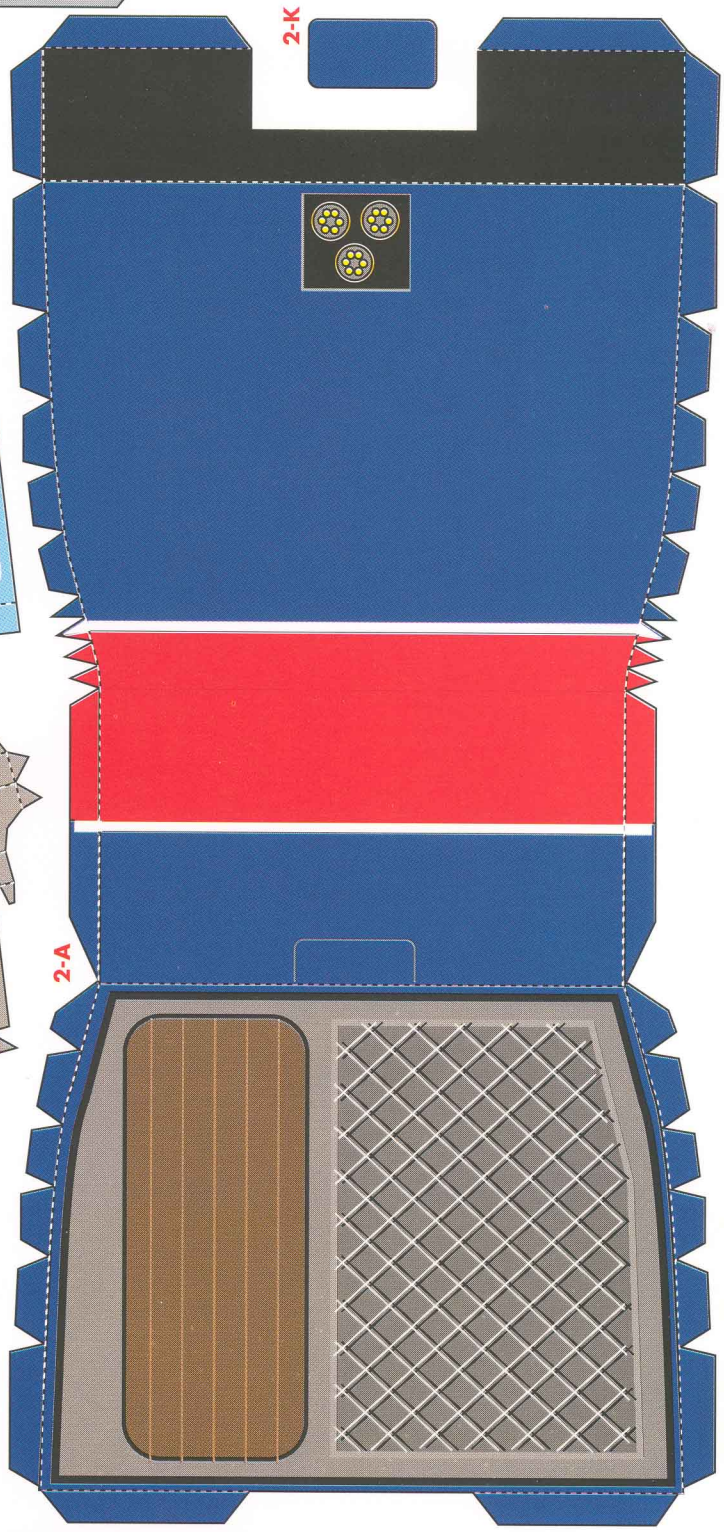

2-K

2-A

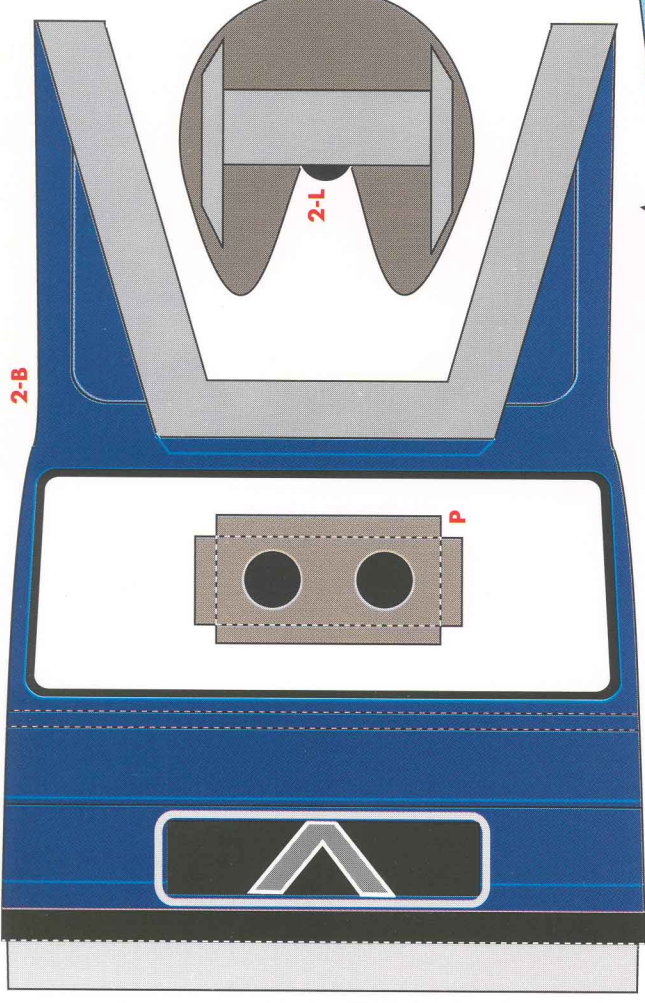

2-B

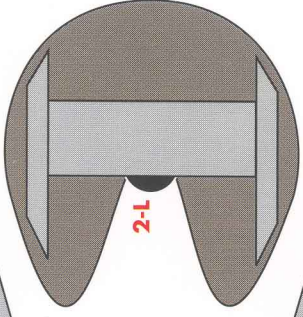

2-L

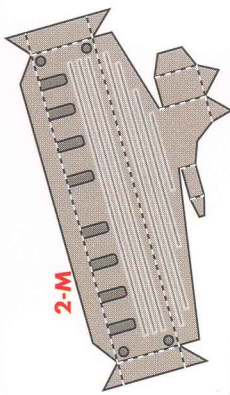

2-M

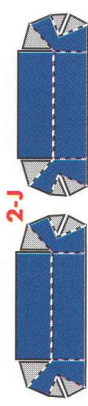

2-J

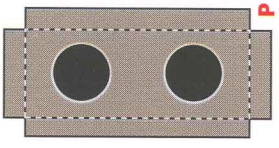

P

RACING TRUCK 3

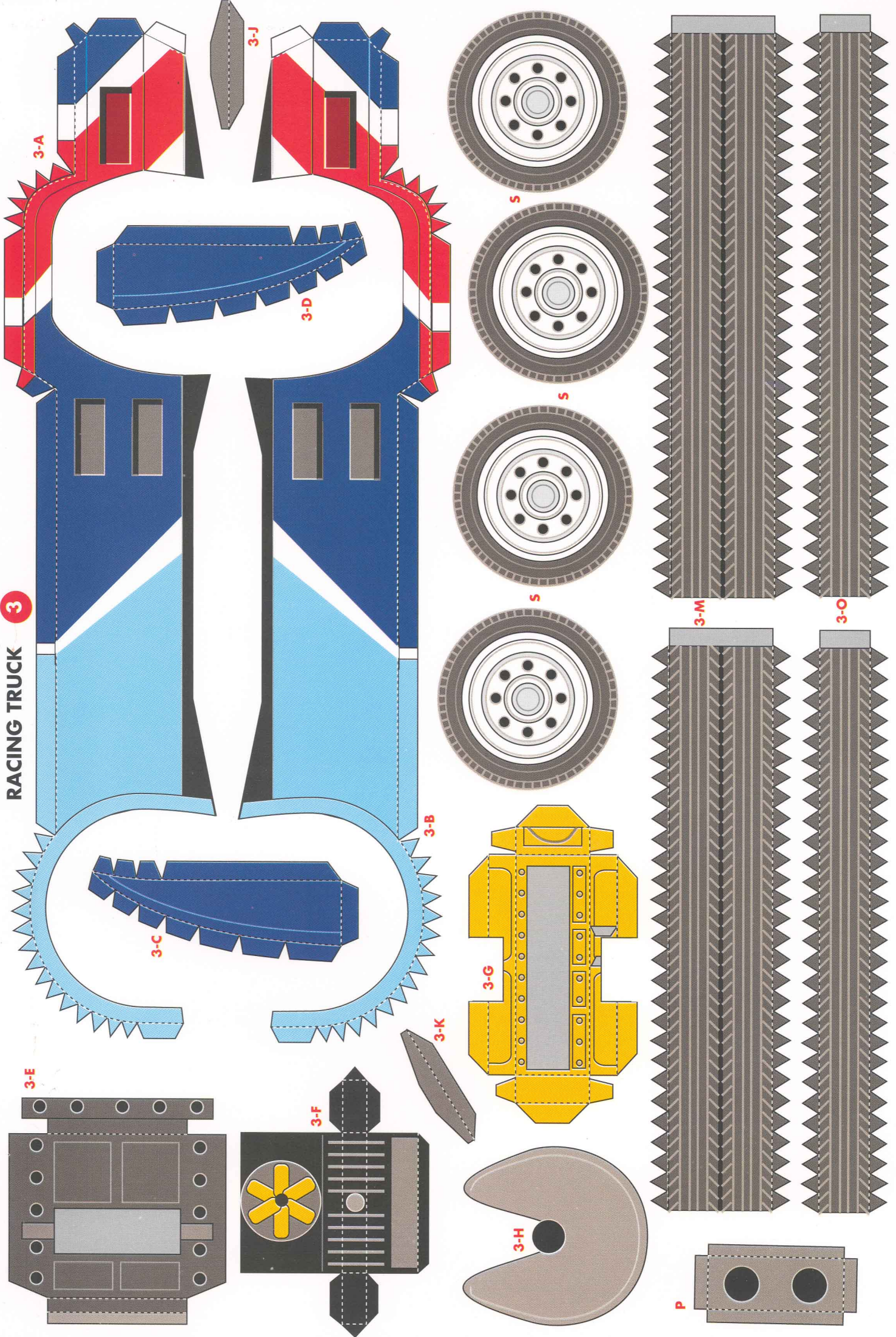

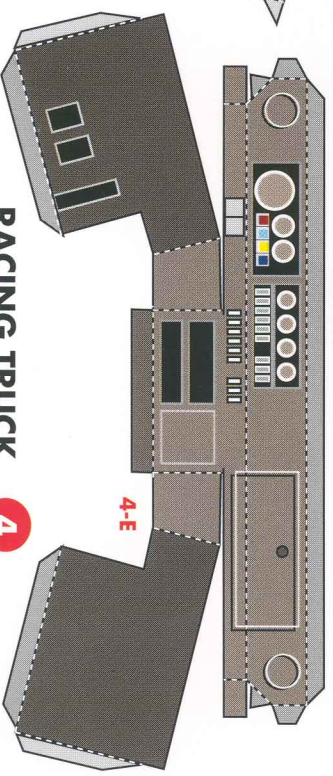
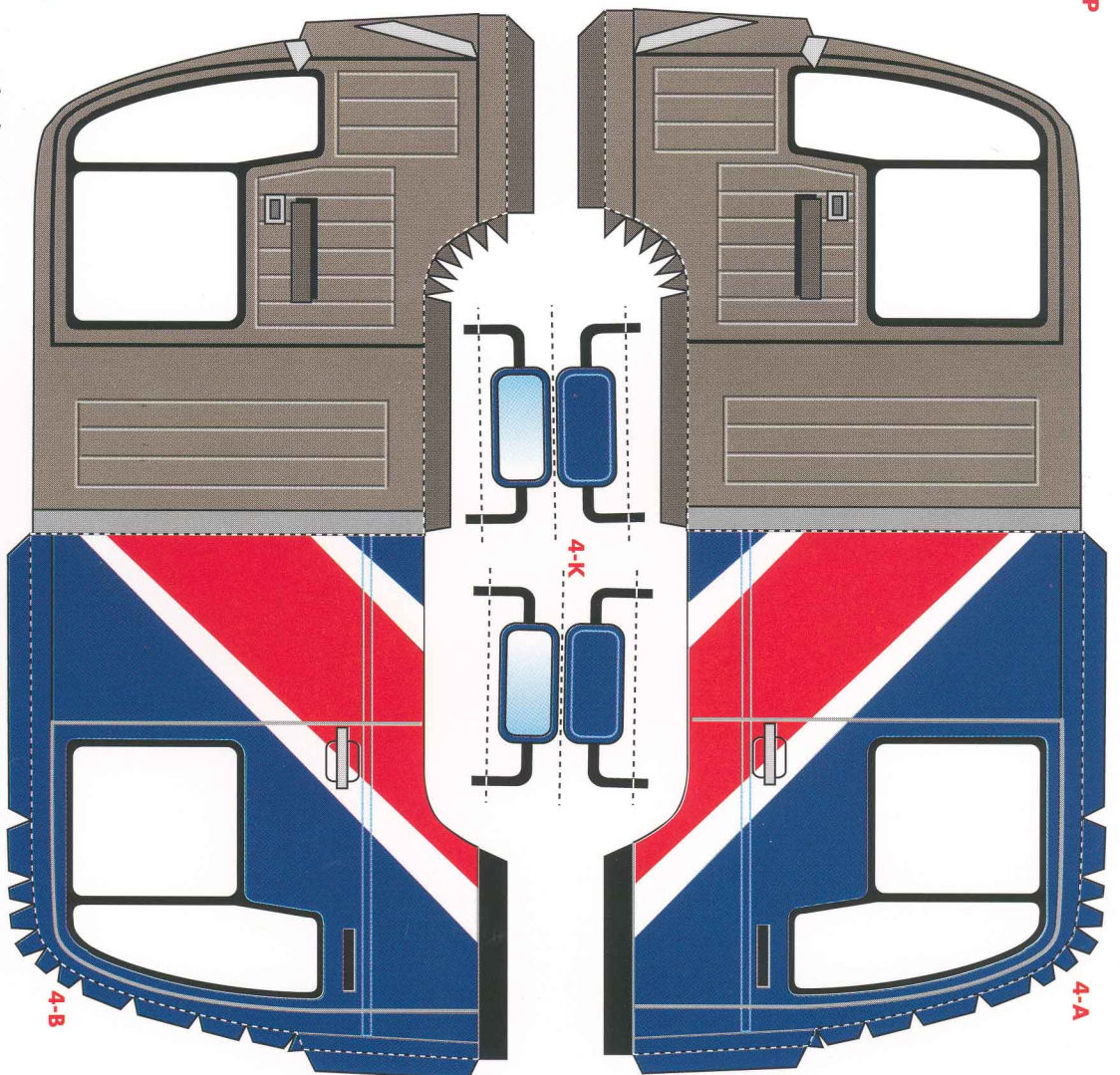
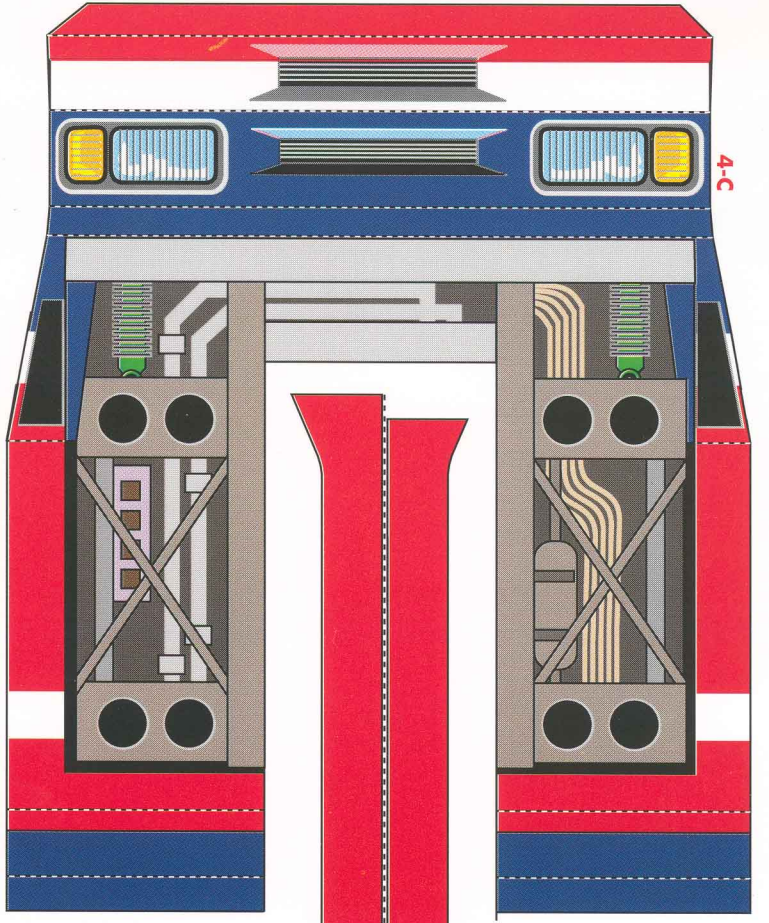
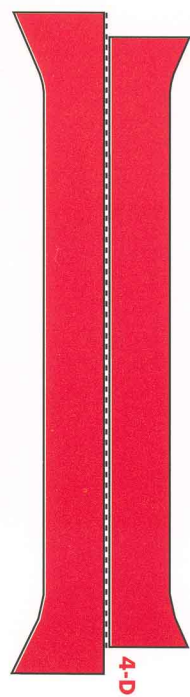
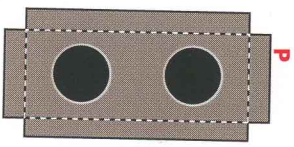
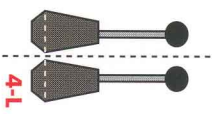
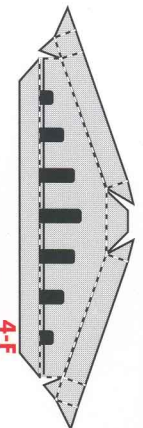
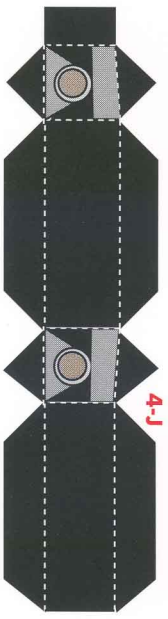
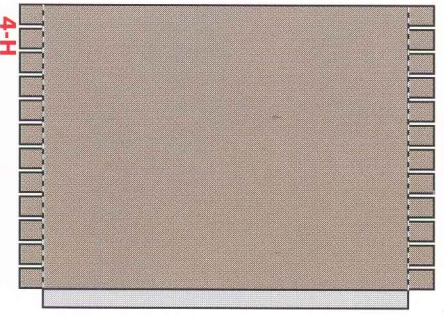
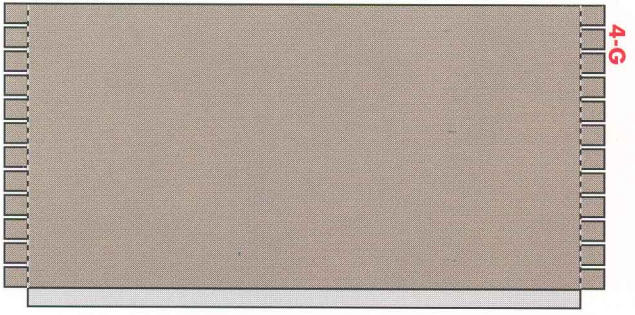
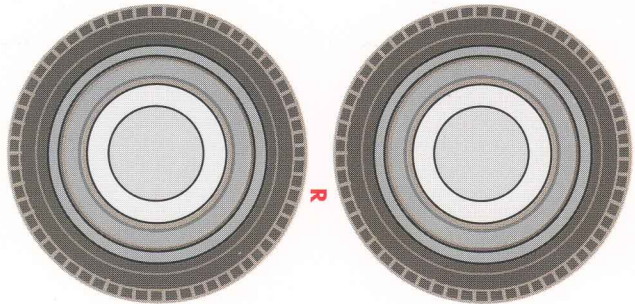

RACING TRUCK



5-C

RACING TRUCK

5

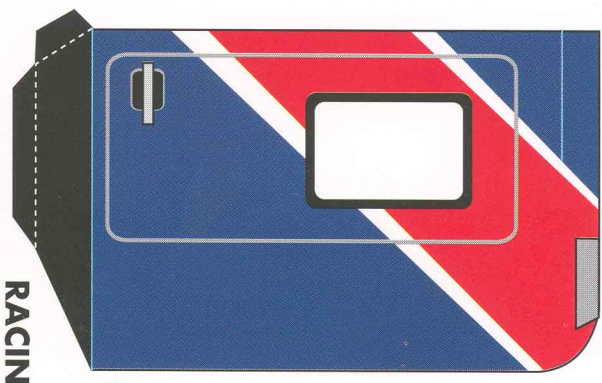

5-B

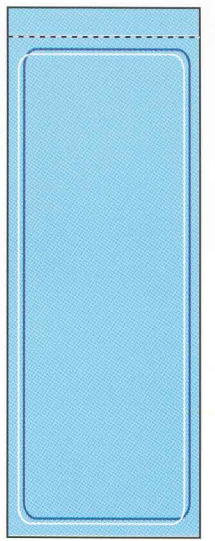

5-D

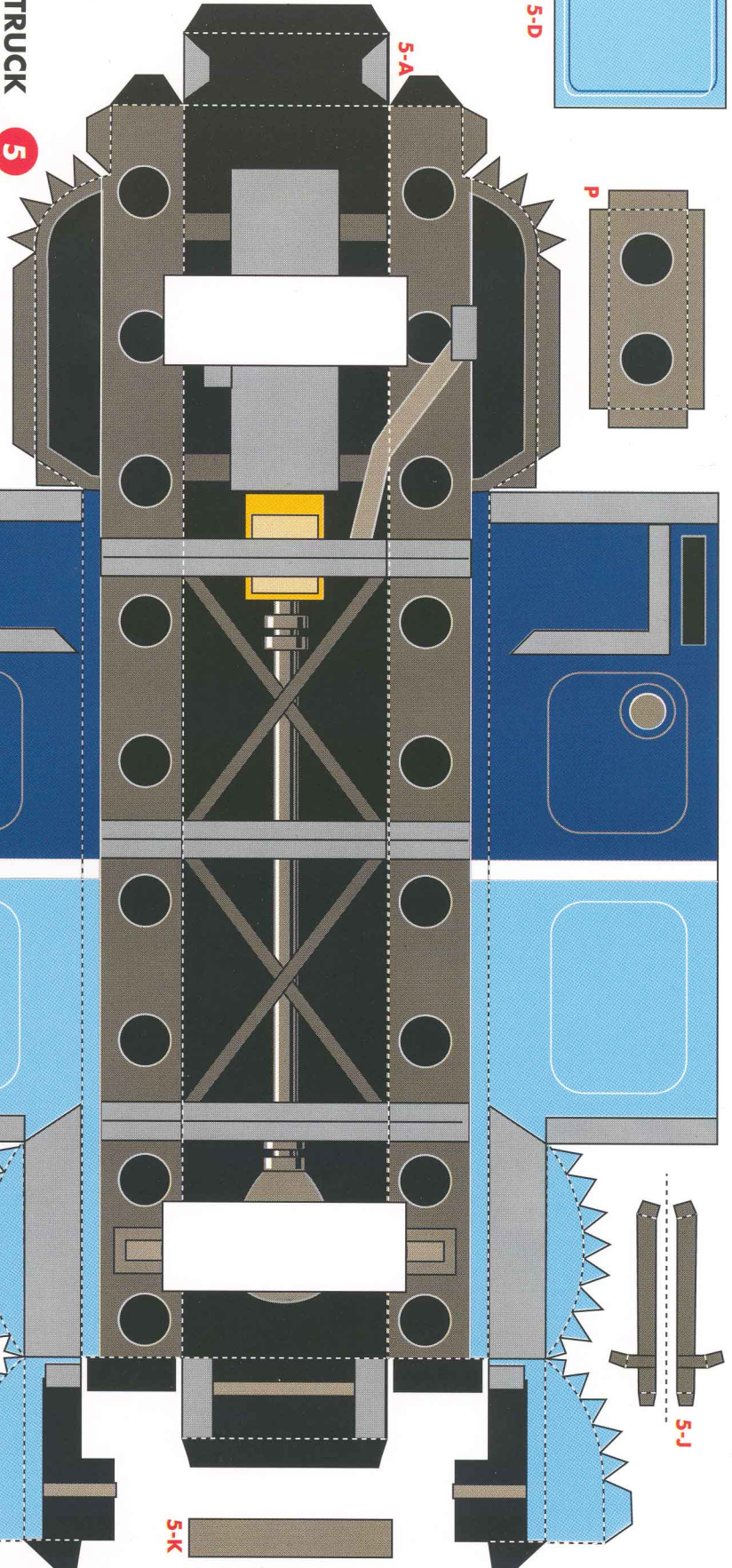

5-A

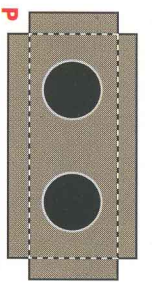

P

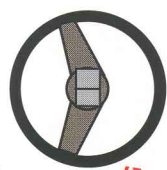

5-H

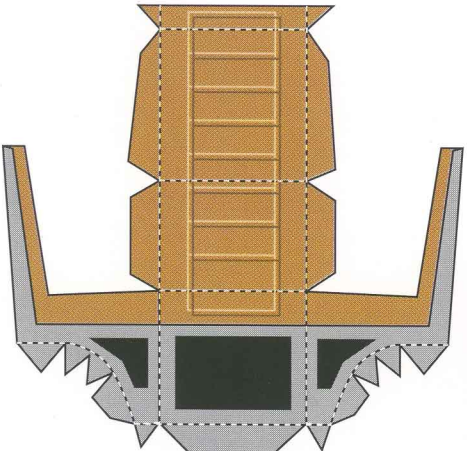

5-G

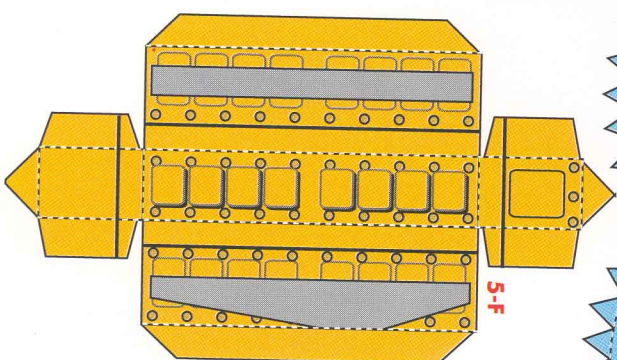
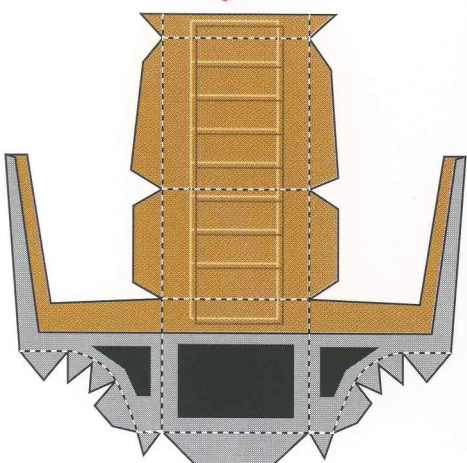

5-F



5-K

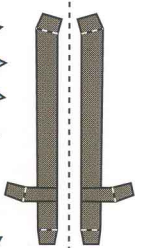

5-J

5-K

A

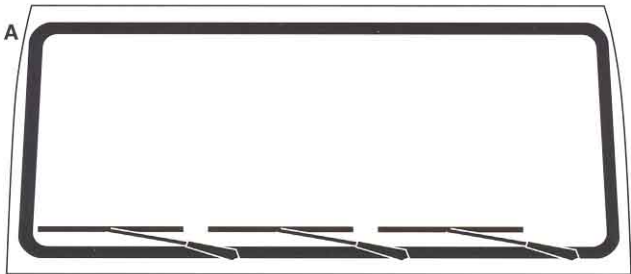

B

RACING TRUCK

C

E

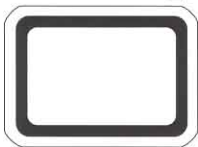

D



F

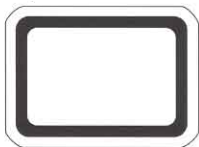

E**INSTRUCCIONES DE MONTAJE:**

Para contruir este recortable se necesita el siguiente material:

Unas tijeras.
Pegamento en tubo para papel.
Una regla.
Unas pinzas para piezas pequeñas.
Un punzón para marcar los pliegues.

Antes de comenzar a cortar y montar, localice y estudie detenidamente cada pieza siguiendo las instrucciones de montaje.

Utilice pegamento transparente universal incoloro líquido (multiuso para adultos o infantil para niños). Evite el uso de cola blanca para madera, barras adhesivas o pegamentos de contacto de color que puedan deteriorar o restar calidad al acabado final de su maqueta.

Le recomendamos realice este paso antes de cortar cada pieza de la lámina impresa:
Para un correcto doblado y encaje de las piezas, los pliegues deberán realizarse con una regla y un punzón siguiendo las líneas ----- según se indica en el dibujo (A).

Utilice pinzas para el manipulado de piezas pequeñas.

Para un mejor acabado de la maqueta, cada vez que termine una pieza o una serie de ellas, retoque todas las esquinas con un rotulador del mismo color (B). Para eliminar las huellas de dedos en el papel utilice polvos de talco.

Utilice el cartón interior como soporte final de su maqueta. (C)

GB**MOUNTING INSTRUCTIONS:**

To construct this cutout you require the following materials:

Nail Scissors.
A tube of paper glue.
A ruler.
Tweezers for small pieces.
A sharp point to mark the folds.

Before starting to cut out and make the model, locate and study carefully each piece, following through the instructions.

Use transparent, universal, colourless liquid glue (multipurpose for adults or non-toxic for children). Avoid using white glue on wood, adhesive sticks or coloured contact glue which may damage or spoil the quality of the final finish of your model.

It is advisable to perform this before cutting each part of the printed sheet.
In order that the pieces fit correctly you should fold them with a ruler and mark the dotted lines with the point ----- as shown in figure (A).

Use the tweezers to handle the small pieces.

For the best finish on the model, colour each join after completion with a felt-tip pen of the same colour. (B)

Use talcum powder to erase finger marks on the paper. Use the cardboard inside as a final base to fix your model. (C)

F**INSTRUCTIONS DE MONTAGE:**

Pour monter ce découpage, on a besoin du matériel suivant:

Des ciseaux.
Tube de colle à papier.
Une règle.
Une pince pour prendre les petites pièces.
Un pointeau pour marquer les plis.

Avant de commencer à découper et monter, situez et étudiez attentivement chaque pièce en suivant les instructions du montage.

Utilisez de la colle liquide incoloro transparente universelle (multi-usage pour adultes ou colle spéciale pour enfants). Evitez l'utilisation de colle blanche à bois, de bâtons de colle ou de colle contact de couleur qui peuvent détériorer ou amoindrir la qualité de la finition de votre maquette.

Nous vous recommandons d'effectuer cette étape avant de couper chaque pièce de la planche imprimée.
Pour doubler et encastrer correctement les pièces, les plis seront faits à l'aide d'une règle et d'un pointeau suivant les lignes - - - - - comme il est indiqué sur le dessin (A).
Utilisez une petite pince pour manipuler les petites pièces.

Pour une meilleure finition de la maquette, chaque fois que vous terminez une pièce ou plusieurs, retouchez tous les coins avec un feutre de la même couleur (B)

Pour éliminer les traces de doigts sur le papier, utilisez du talc. Utilisez le carton intérieur comme support définitif de votre maquette. (C)

D**MONTAGEINSTRUKTIONEN**

Zum Zusammenbauen dieses Ausschneidmodelles wird folgendes benötigt:

Scheren.
Papierkleber aus der Tube.
ein Lineal.
eine Pinzette für die Kleinen Teile.
ein Bastelmesser zur Markierung der Perforierung.

Vor Beginn des Ausschneidens und Zusammenbauens empfehlen wir Ihnen, jedes Teil zu suchen und sorgfältig unter Befolgung der Montageinstruktionen zu studieren.

Benutzen Sie farblosen, transparenten Flüssigklebstoff (Mehrzweckklebstoff für Erwachsene oder Kinder). Vermeiden Sie den Gebrauch von Weißem Leim für Holz, Klebstiften oder Farbkontaktklebern, die die Qualität des Finishings Ihres Modelles verschlechtern oder Schädigen könnten.

Wir empfehlen Ihnen, diesen Schritt vor dem Jeweiligen Ausschneiden der Gedruckten Lamelle durchzuführen. Für eine korrekte Faltung und Einfügung der Teile, sollten die Perforationen den Linien folgend mit einem Lineal und einem Bastelmesser behandelt werden, so wie es in der Zeichnung A aufgezeigt ist.

Benutzen Sie zur Handhabung von kleinen Teilen Pinzetten.

Für eine bessere Fertigstellung des Modelles sollten Sie nach Anbringung jedes Teiles oder, nach mehreren Teilen alle Ecken mit einem Filzstift derselben Farbe nachbessern (B).

Um Fingeardrücke auf dem Papier zu Vermeiden, benutzen Sie, bitte, Talcum Puder. Benutzen Sie den Inneren Karton als Unterlage für Ihr Modell. (C)

I**ISTRUZIONI DI MONTAGGIO**

Per costruire questo ritagliabile bisogna il seguente materiale:

Forbice.
Colla in tubo per carta.
Una regola.
Pinze per i pezzi piccoli.
Un punzone per marcare i piegamenti.

Prima di incominciare a tagliare ed a montare, localizzate e studiate sostantemente ogni pezzi seguendo le istruzione di montaggio.

Utilizzare colla trasparente universale incoloro liquida (multiuso per adulti o tipo per bambini). evitare l'uso di colla bianca per legno, adesivi o colle di contatto colorate che possano deteriorare o diminuire la qualità del risultato finale del vostro modellino.

Raccomandiamo realizzare questo passaggio prima di tagliare i pezzi dalla tavola prestampata.
Per una corretta piegatura ed inserimento dei pezzi, i pieghi dovranno essere realizzati con una regola e un punzone seguendo le linee.....secondo il disegno (A).

Utilizzare pinze per il manipolato di pezzi piccoli.

Per una migliore finizione dal modellino, ogni volta quasi finisce un pezzo o una loro serie, ritoccare i spigoli con un pennarello dello stesso colore. (B).

Per eliminare le impronte delle dita sulla carta utilizzare talco. Utilizzare il cartone interiore come sopporto finale del modellino. (C)

P**INSTRUÇÕES DE MONTAGEM**

Para construir este recortável é preciso o seguinte material:

Tesouras.
Cola em tubo, para papel.
Uma régua.
Pinças para peças pequenas.
Um buril para marcar as dobras.

Antes de começar a cortar e montar, localize e estude com atencao cada peça, seguindo as instruções de montagem.

Utilize cola transparente universal incoloro líquida (multi-uso para adultos ou infantil para crianças). Evite o uso de cola branca para madeira, barras adhesivas ou colas de contacto de cor que possam deteriorar ou reduzir a qualidade do acabamento final da sua maqueta.

Recomendamos-lhe realizar este passo antes de cortar cada peça da lâmina impressa.
Para dobrar e encaixar correctamente as peças, as dobras devem fazer-se com uma régua e um buril, seguindo a linha pontilhada, assim como indicado na Figura. (A).

Use pinças para trabalhar com as peças pequenas.

Para uma melhor acabamento da maqueta, ao terminar uma peça ou uma série delas, retoque os cantos com uma caneta de feltro da mesma cor. (B)

Para eliminar as impressões dos dedos no papel use talco. Utilize o cartão interior como suporto final da maqueta. (C)

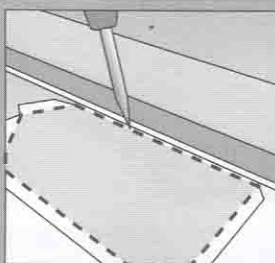
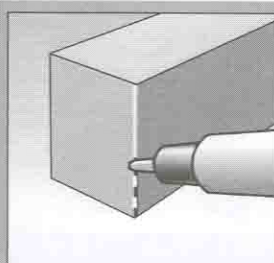
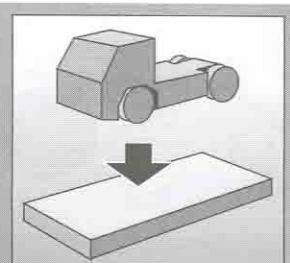
**(A)****(B)****(C)**