

STUKA

JUNKERS
JU 87 B

KARTONOWE
mini ABC 10'99
ISSN 1428 - 4628



DŁUGOŚĆ MODELU 57 cm
ROZPIĘTOŚĆ MODELU 45 cm
WYSOKOŚĆ MODELU 17 cm

skala 1:24

STOPIEŃ TRUDNOŚCI

1

2

3

GPM

<http://www.gpm.pl>

NR KAT. 240

SERIA "€"

Rys.3

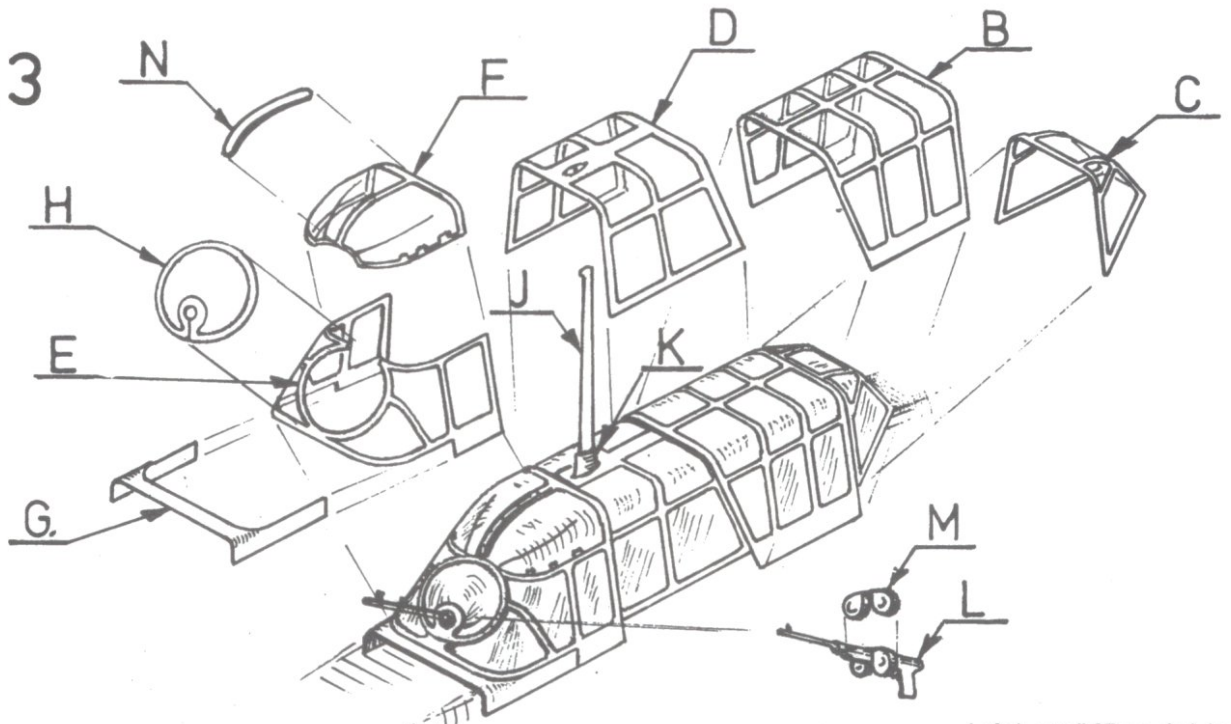

Lufę k-mu dł.37mm, śr.1,1mm
wykonać we własnym zakresie

Rys.2

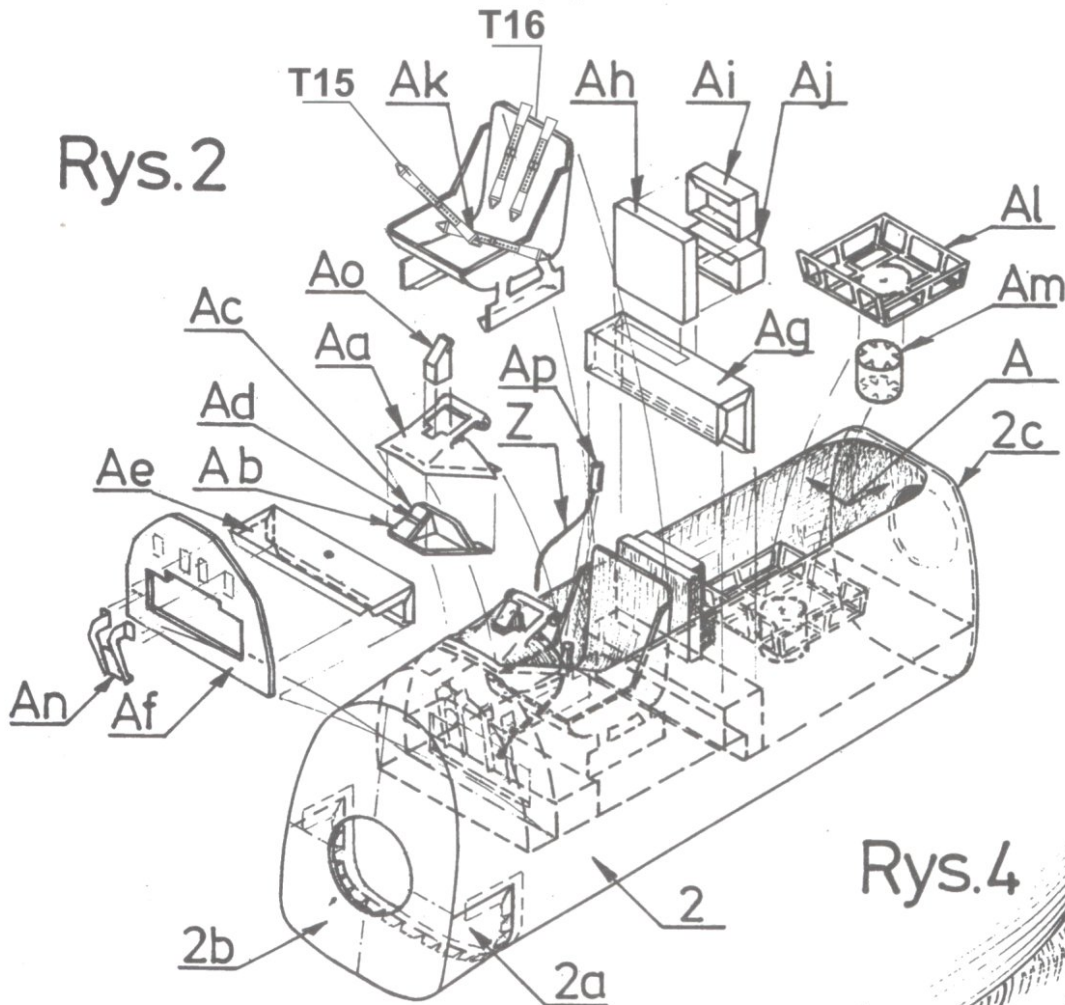

Rys.6

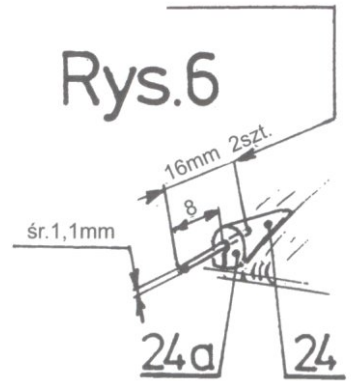

Rys.4

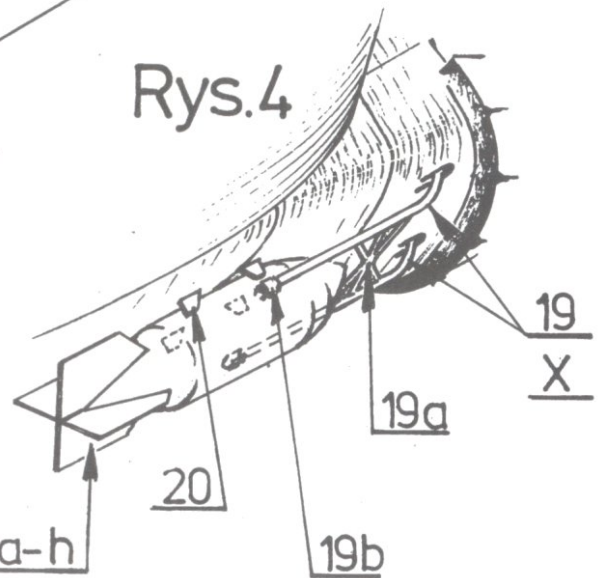

Rys.5

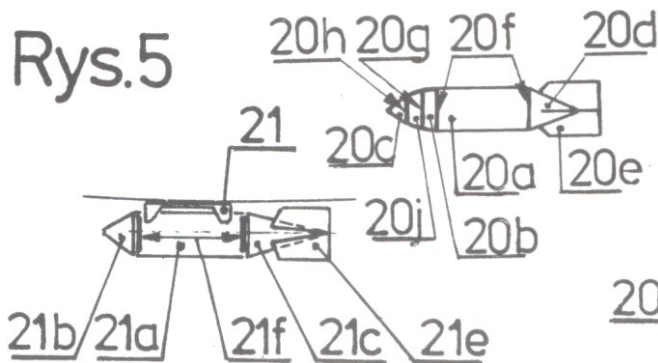

Rys.1

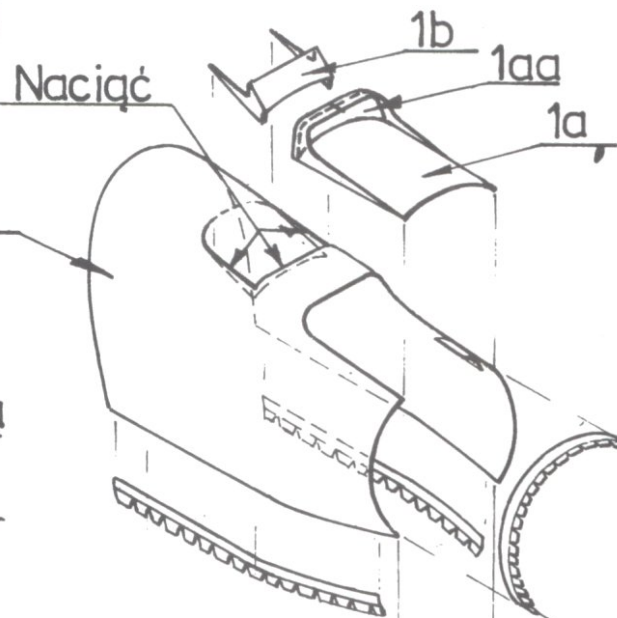

Rys.8

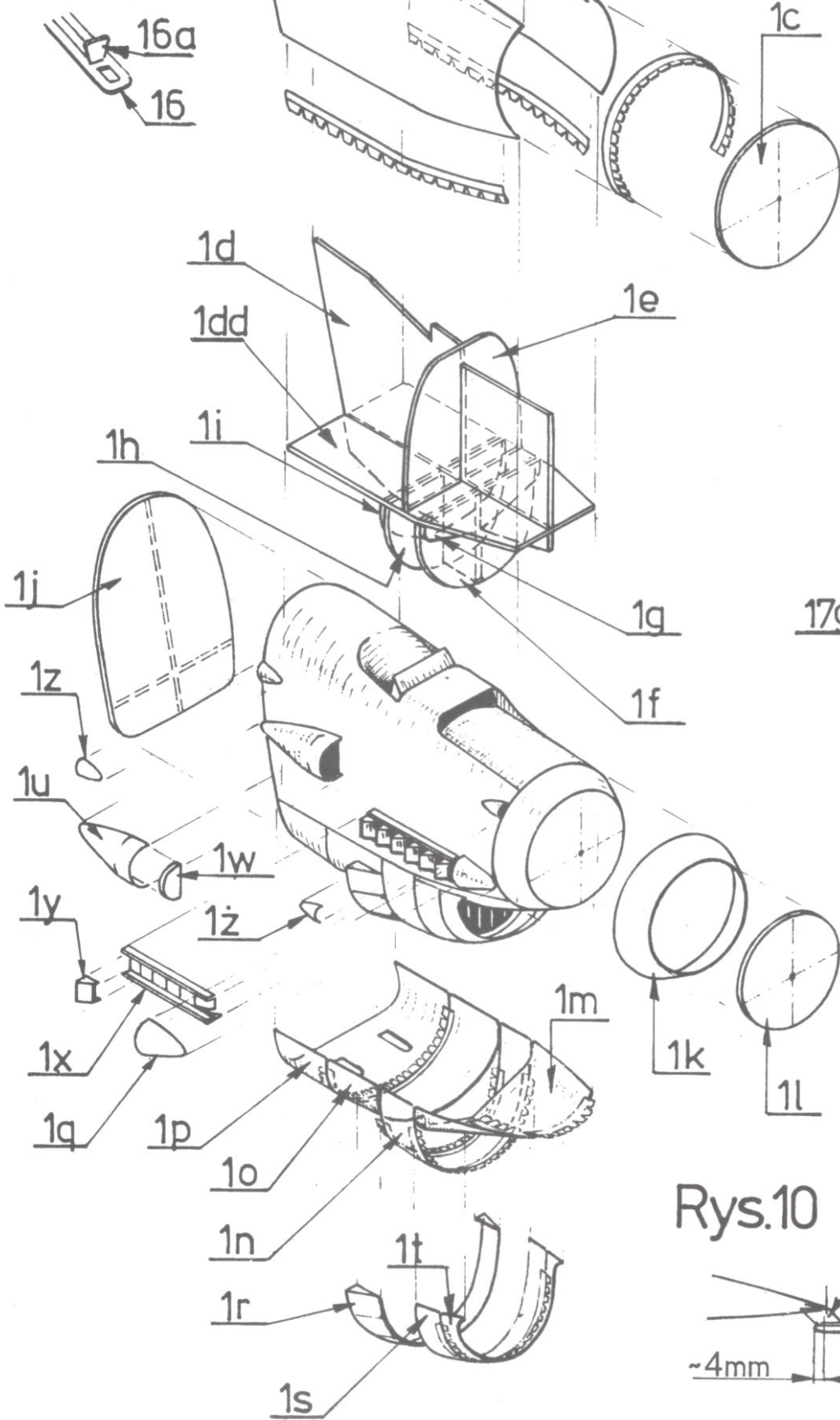

Rys.7

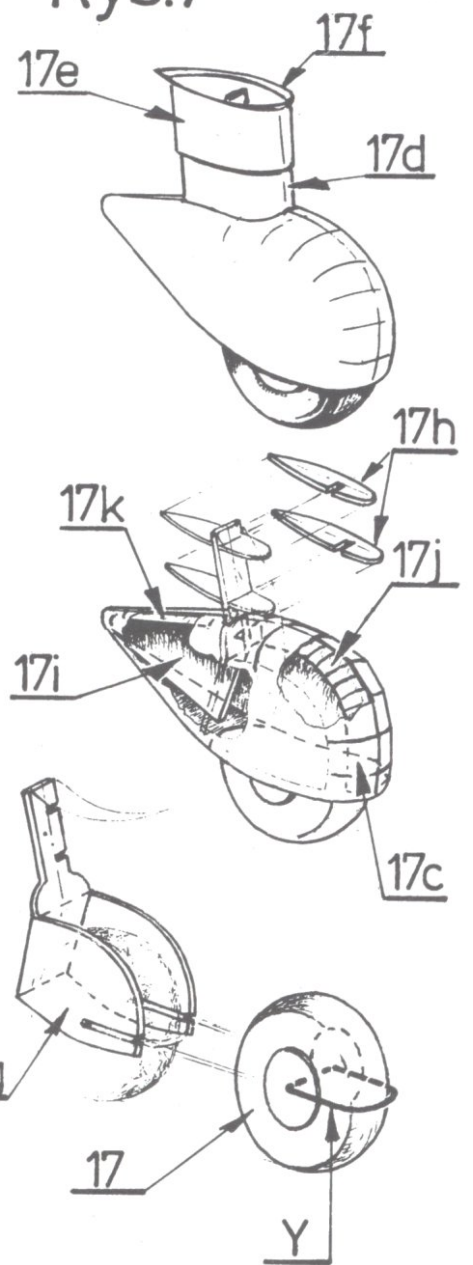

Rys.9

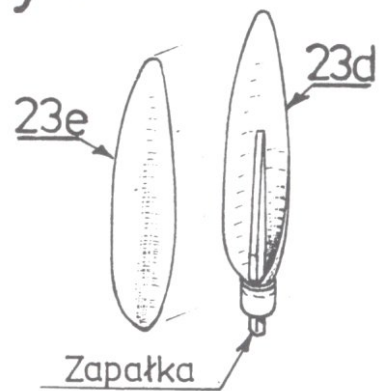

Rys.10

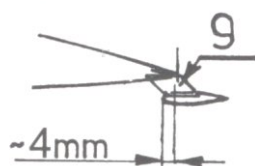

Rys.11

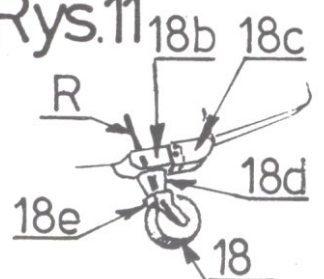

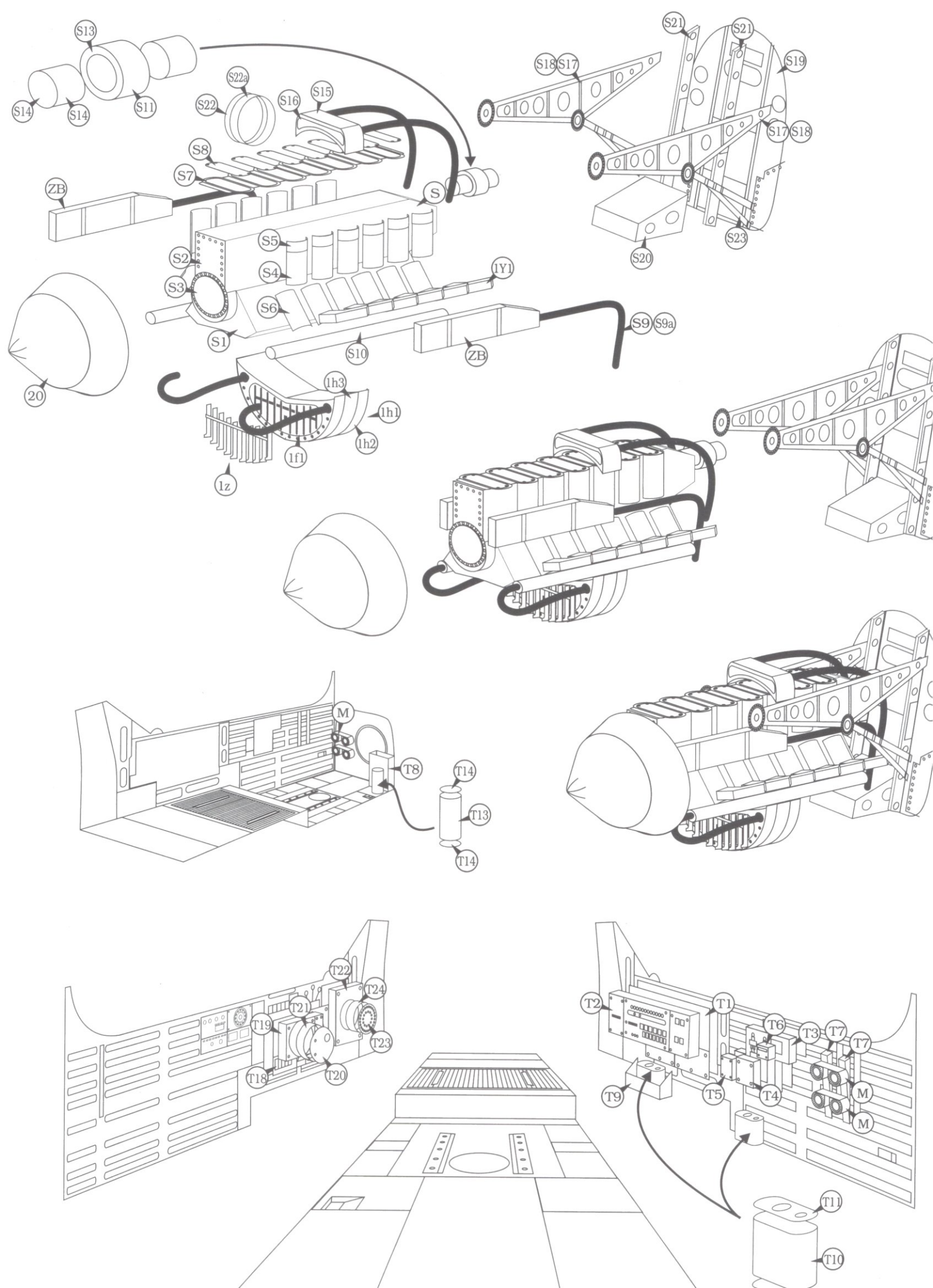

- modelarzowi który już budował modele z kartonu;
- model budowany metodą "wręga do wręgi" wymaga aby sąsiadujące wręgi tzn. 1j-2b, 2c-3a, 3b-4a, 4b-5c, były po wycięciu doszlifowane razem na papierze ściernym,
- krawędzie części po wycięciu z arkusza należy zamalować odpowiednio dobranym kolorem,
- do klejenia używać kleju "Butapren" lub "Falco",
- odpowiednie części na arkuszu 5 należy podkleić tekturą, grubość tektury dopasować w zależności od elementów,
- wszelkie niedokładności malujemy odpowiednio dobranym kolorem,
- po sklejeniu można model polakierować w celu zabezpieczenia.

Model możemy zbudować z odkrytym lub zakrytym silnikiem. Wybór należy do modelarza. W wersji z silnikiem zakrytym części o numeracji od cz. S do cz. S23 oraz cz. ZB i 1y1 są zbędne.

Budowę modelu (w wersji z silnikiem zakrytym) rozpoczynamy od segmentu cz. 1p, 1 i cz. 1b; 1aa; 1a oraz szkieletu cz. 1, które należy przykleić przed montażem. Następnie

Następnie wykonujemy kolejny segment a2 wg rysunku 2 oraz rysunku dodatkowego. Wyposażenie kabiny i kabinę montujemy później. Pozostałe segmenty 3 i 4 wykonać należy wg rys. zestawieniowego, wzmacnić dźwigarami i żebrami wg rys. 10, przyklejając lotki i klapy cz. 9; 10; 11; i przykleić elementy 12; 13; 14; 15; (cz. 12 zwinąć w rurkę lub wykonać z drutu). Podwozie cz. 17 wykonać wg rys. 7 z odpowiednich elementów i podkleić skrzydłami. Koło ogonowe cz. 18 wykonać wg rys. 11. Zaczep bomby cz. 19 i cz. 20; 21 wykonać wg rys. 4 i 5 jednak przykleić je dopiero po zakończeniu całości modelu. Następnie przyklejamy do modelu kabiny (osłony) i wyposażenie wg rys. dodatkowych. Kołpak i śmigła wykonujemy z cz. 23 wg rys. 9 i rys. zestawieniowego, pamiętając o włożeniu szpilki o ile ma być obracany. Pozostałe części tzn. 22 i 24 przyklejamy wg rys. 6 i rys. zestawieniowego. Po sklejeniu modelu wykonujemy antenę z nici.

Wszelkie niedokładności malujemy farbą.

Model możemy wyposażyć w makietę silnika, bez osłaniających go pokryw. Makietę silnika wykonujemy zgodnie z rysunkami montażowymi.

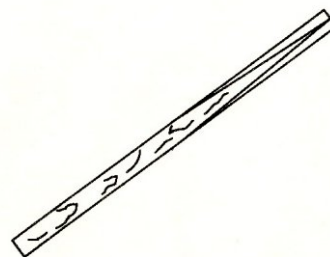
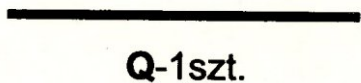

Wykonać z cienkiej listewki - 3szt.

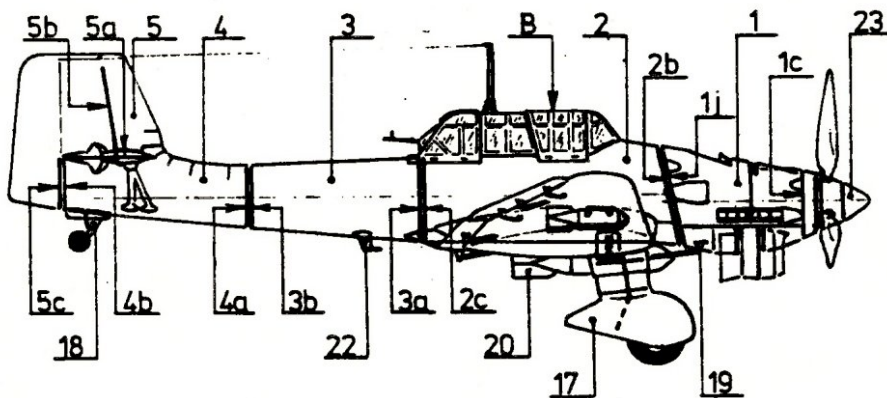
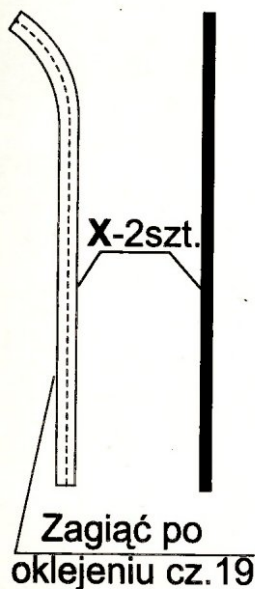
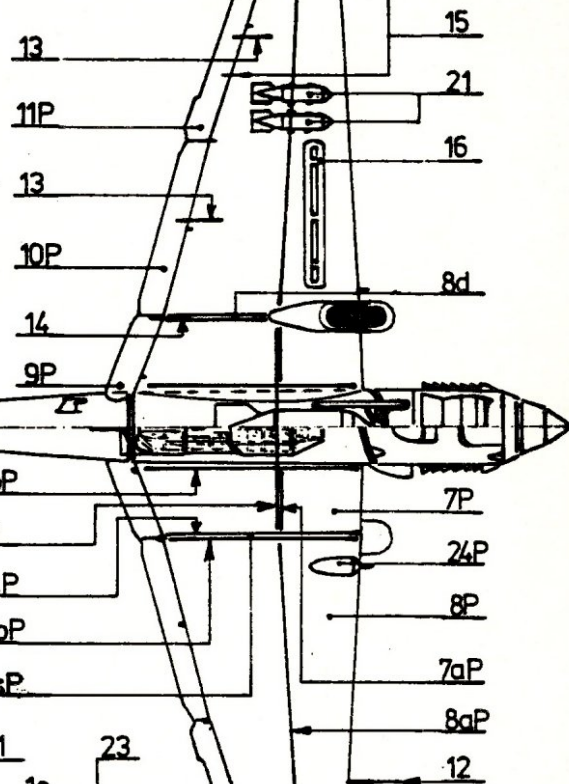
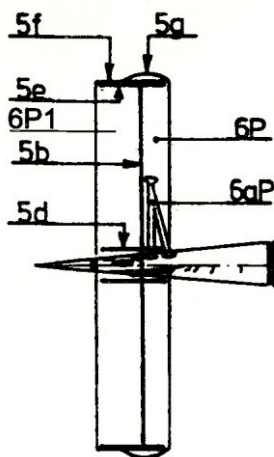
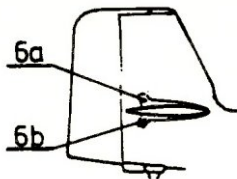
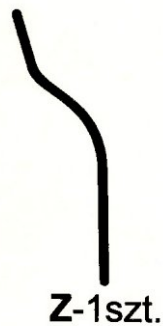
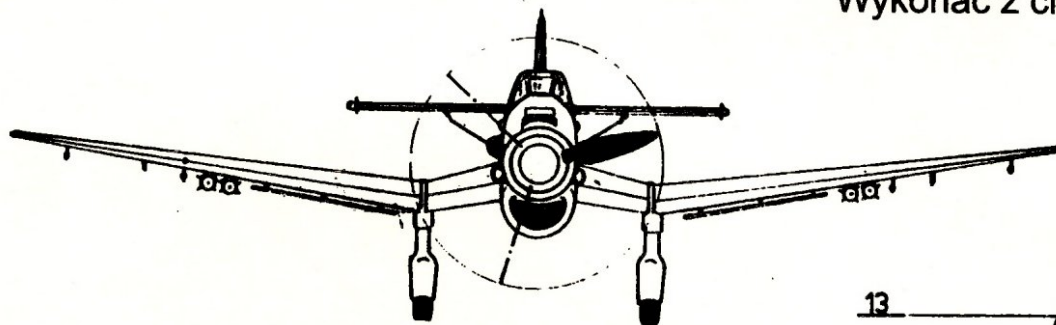



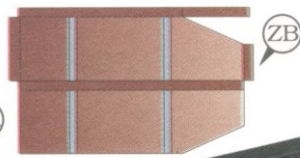
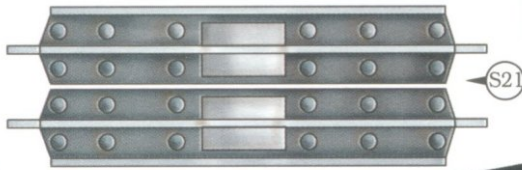
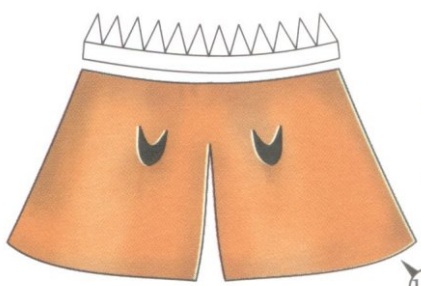

8L

