

# F-14A „BLACK TOMCAT”

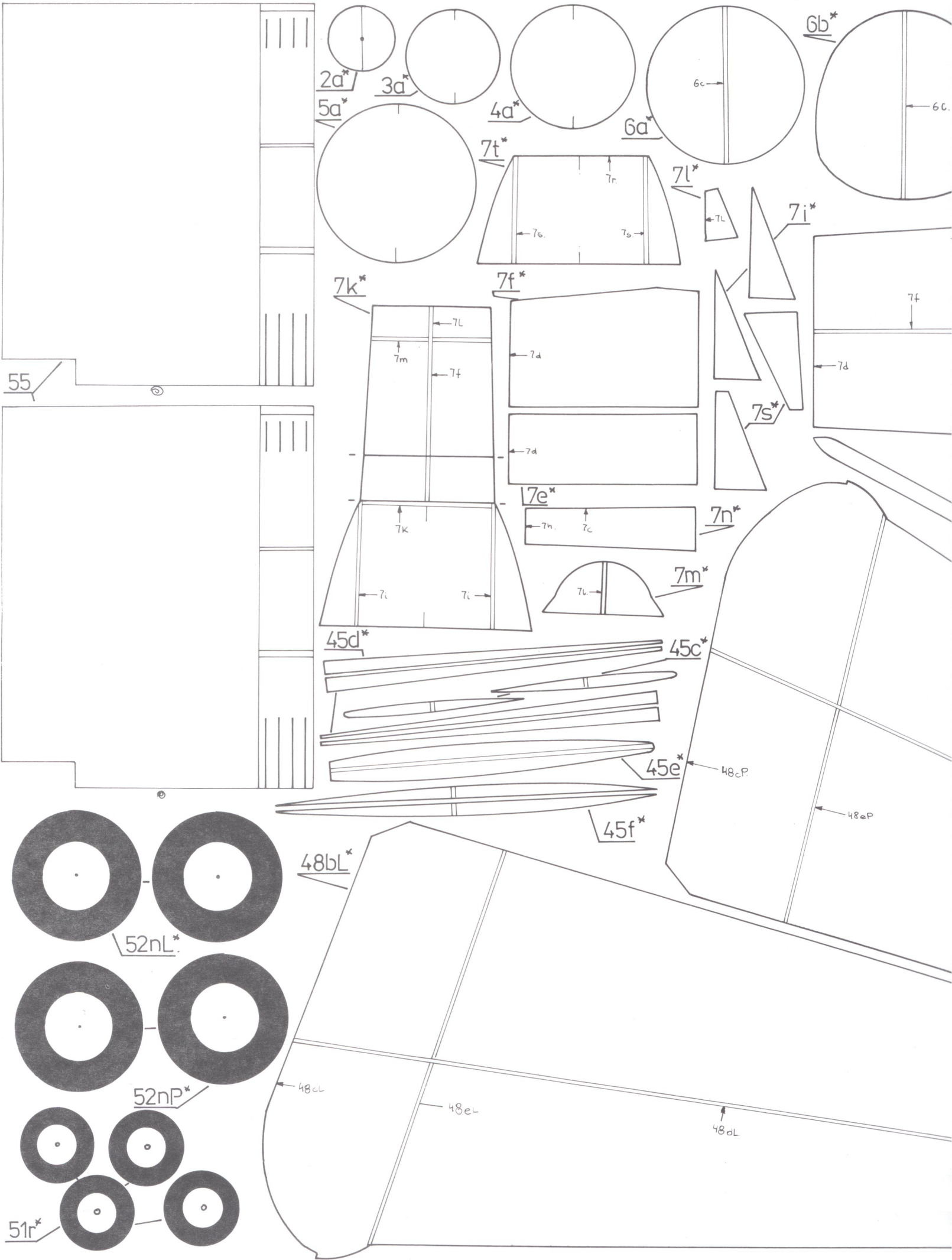

**Fly Model**®  
**Nr 121**  
ISSN 1233-9423  
WYDANIE I

MODEL  
KARTONOWY  
**1:33**



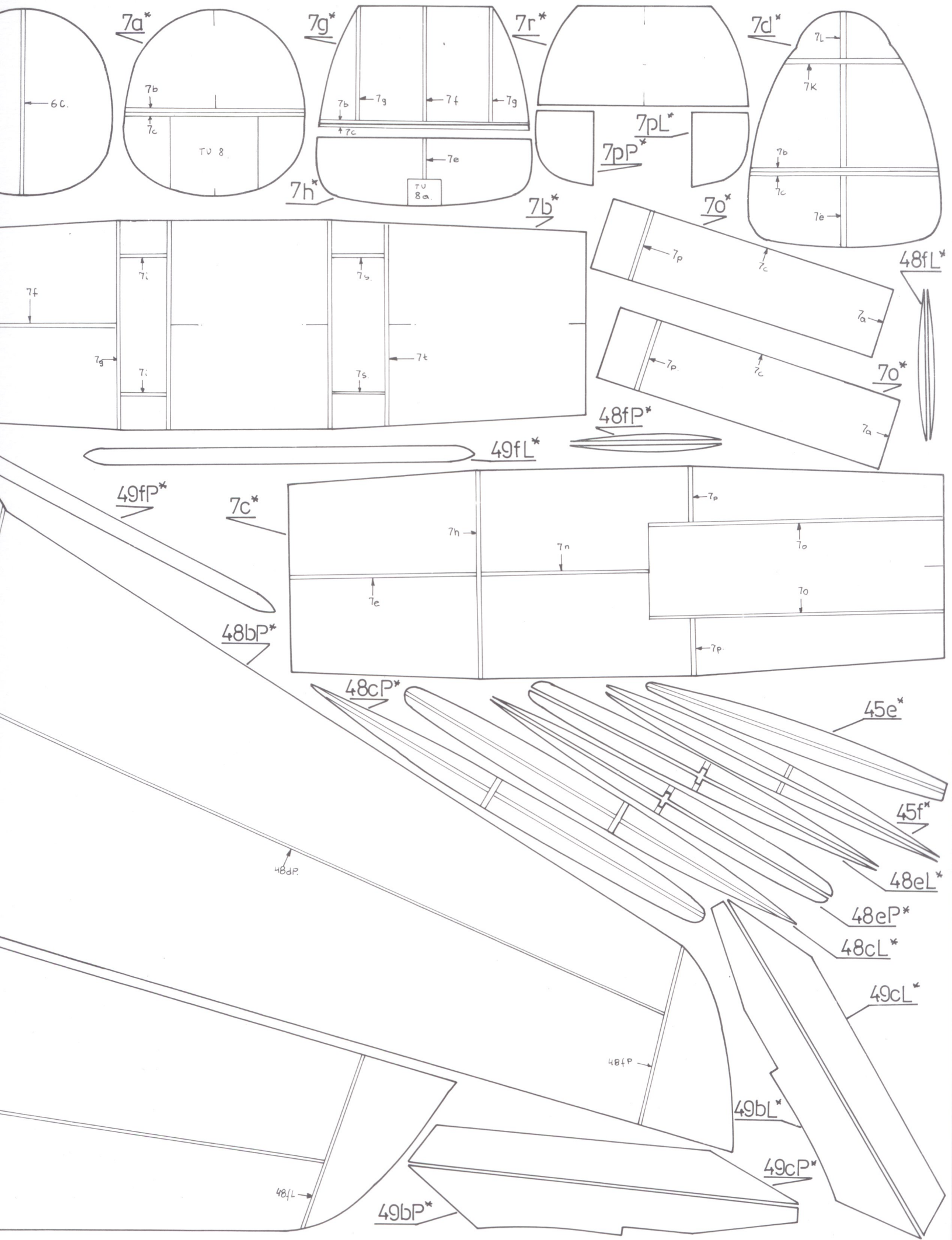

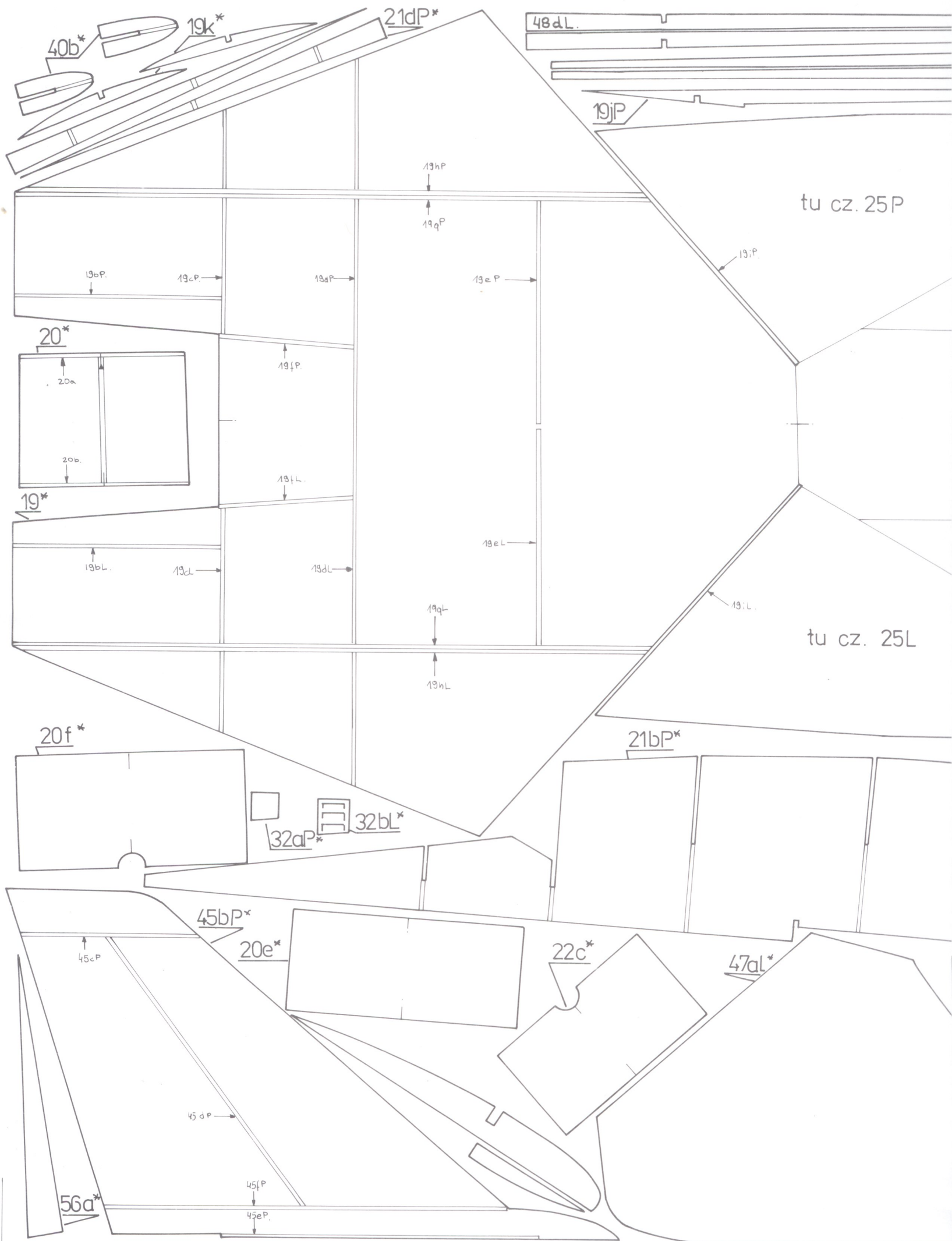

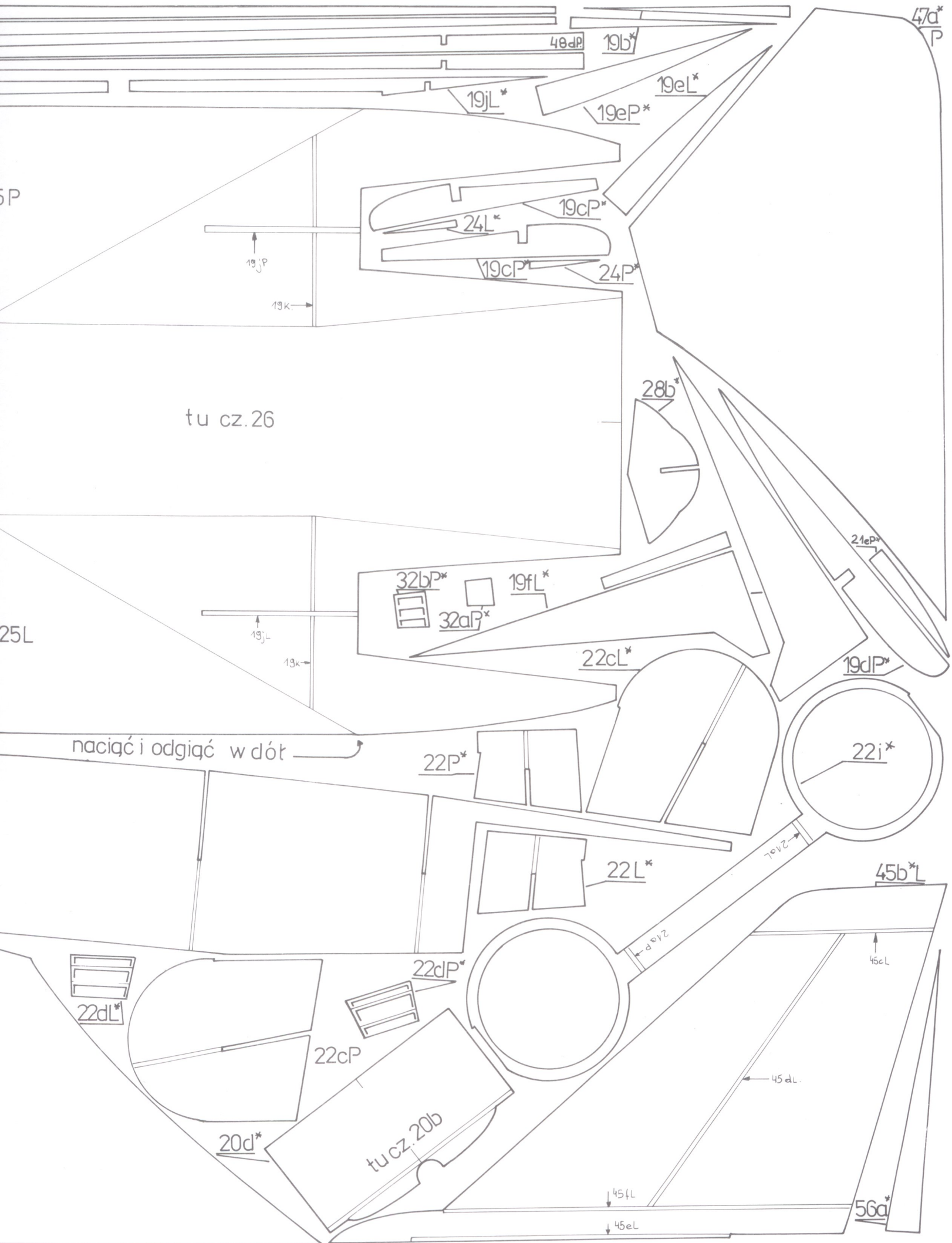

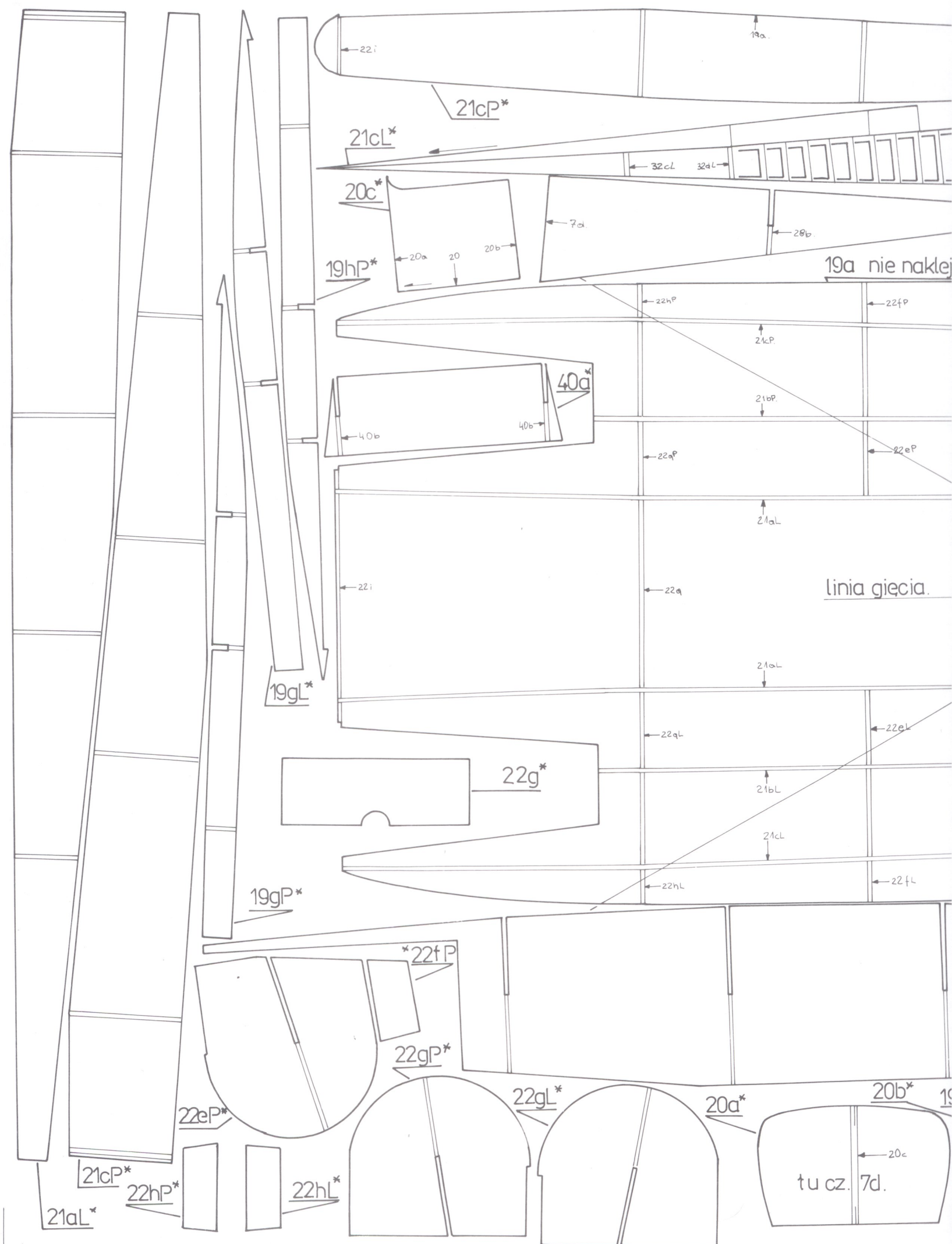

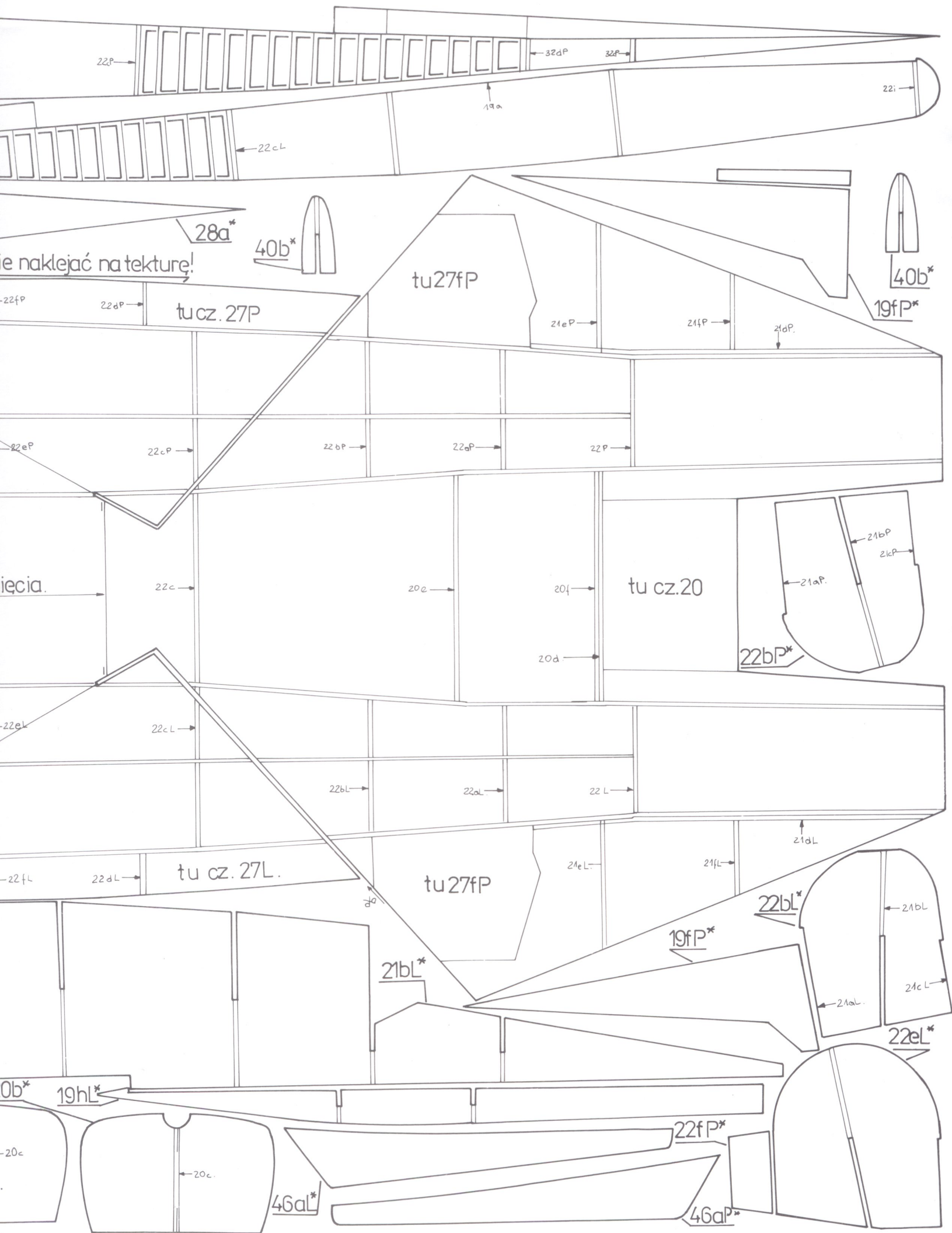





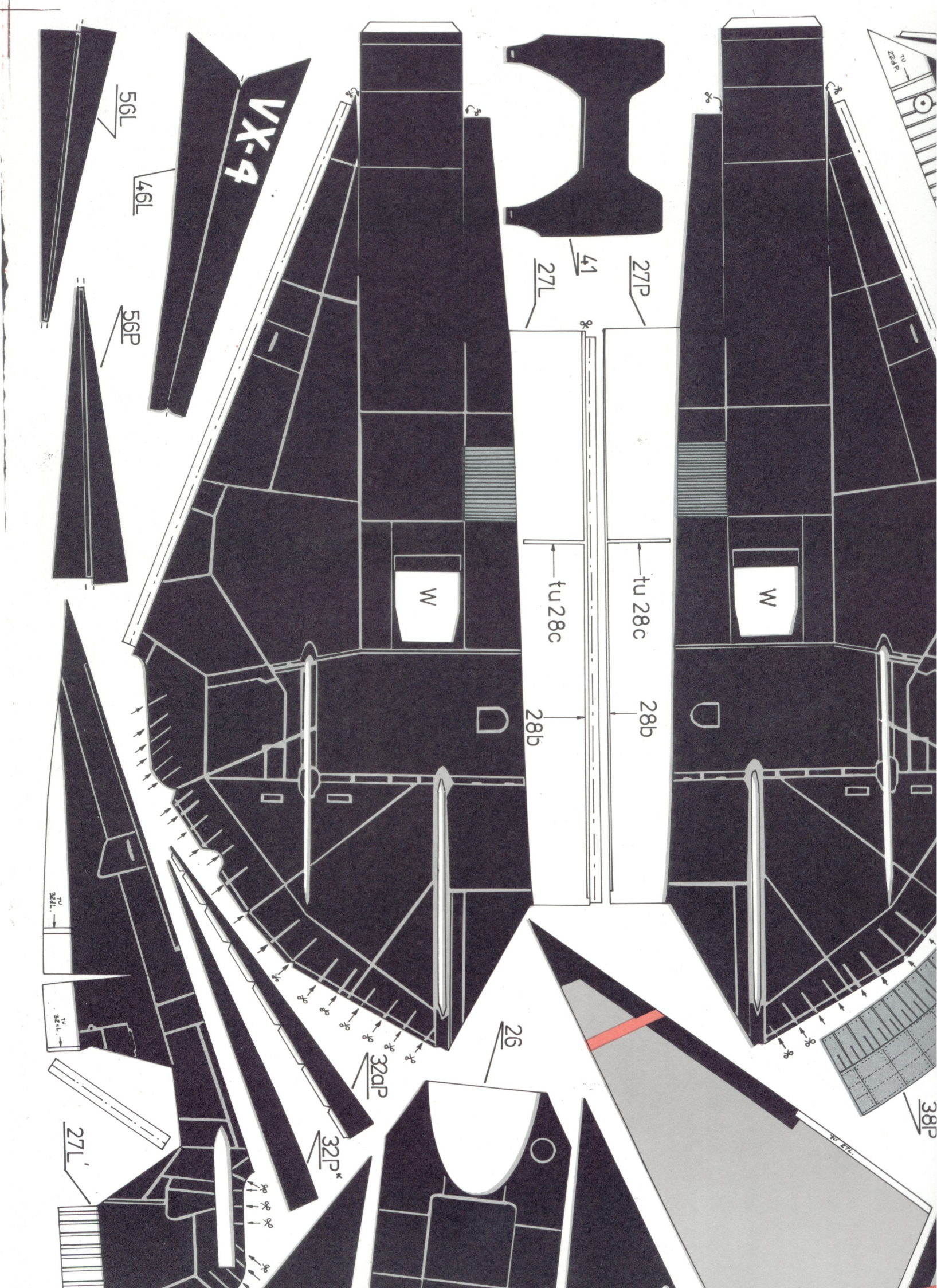

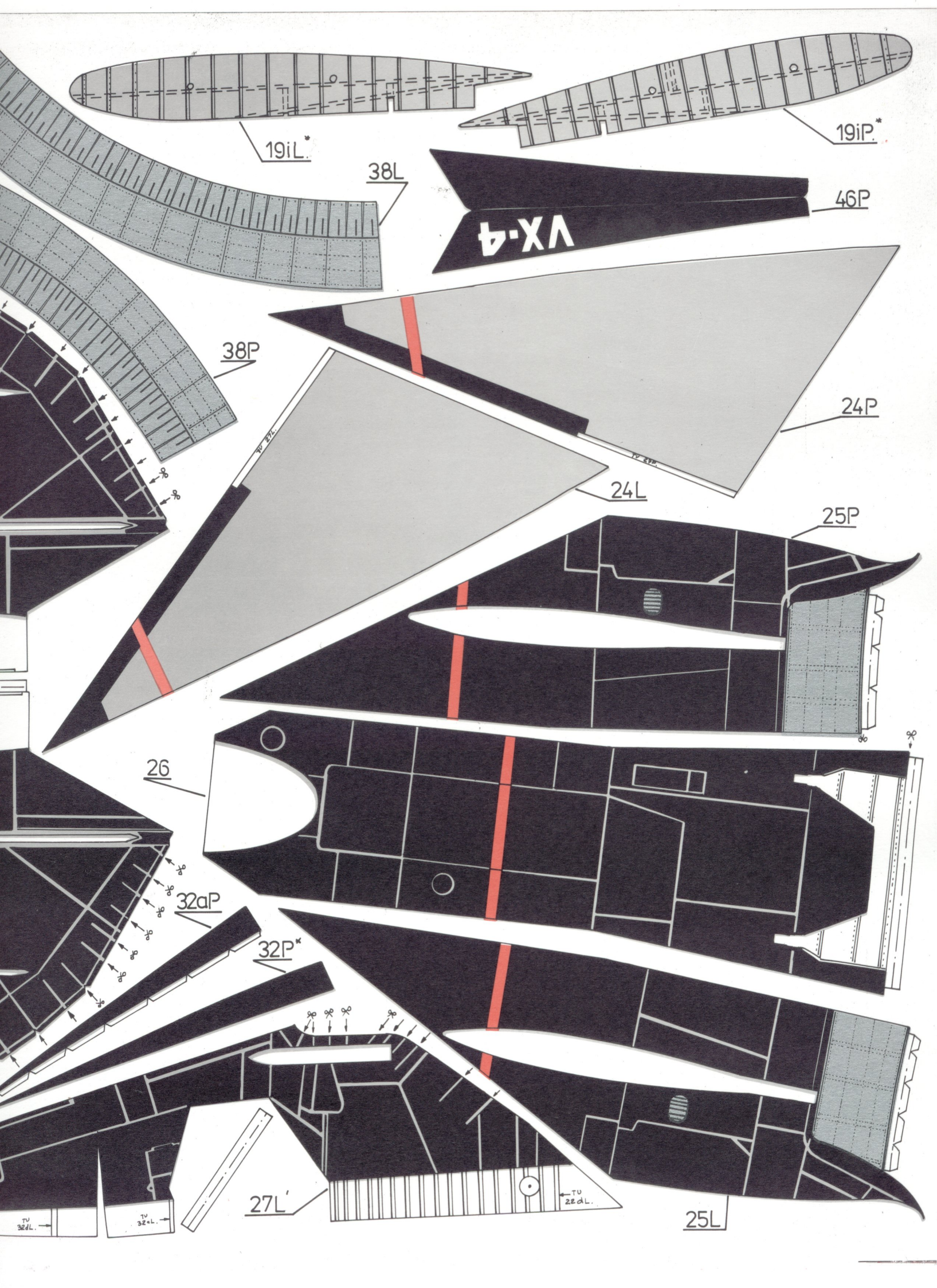

19iL\*

19iP\*

38L

46P

V-X-4

38P

24P

24L

25P

26

32aP

32P\*

27L

TU  
22dL.

25L

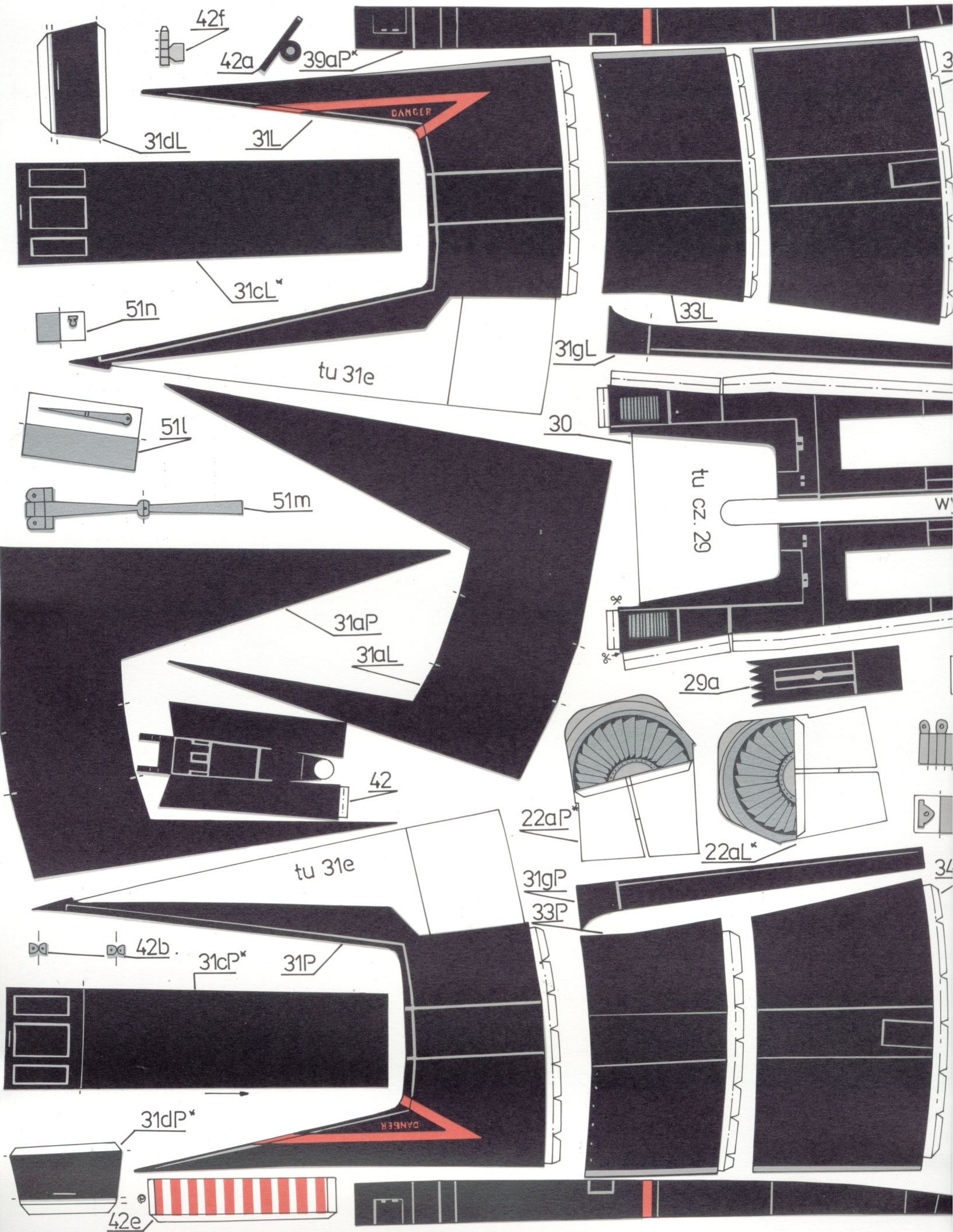

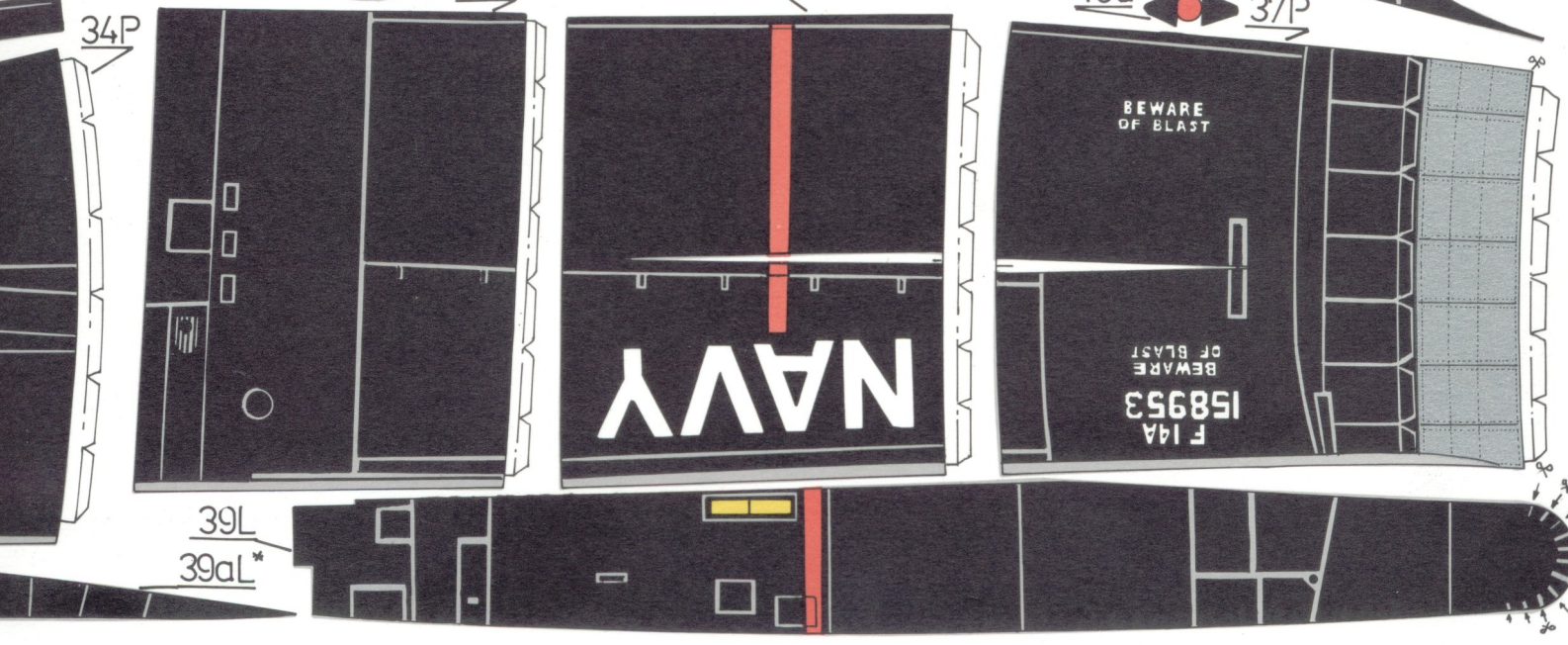
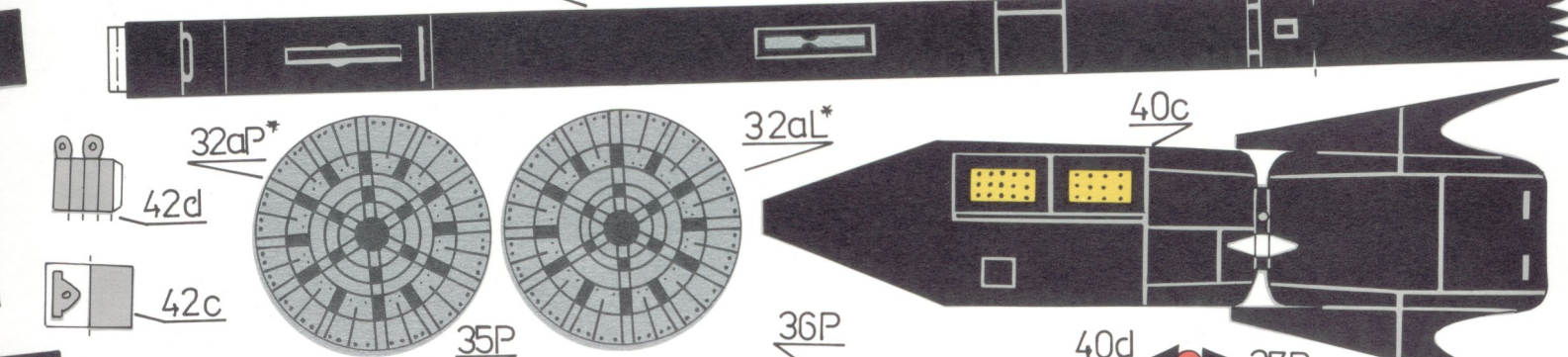
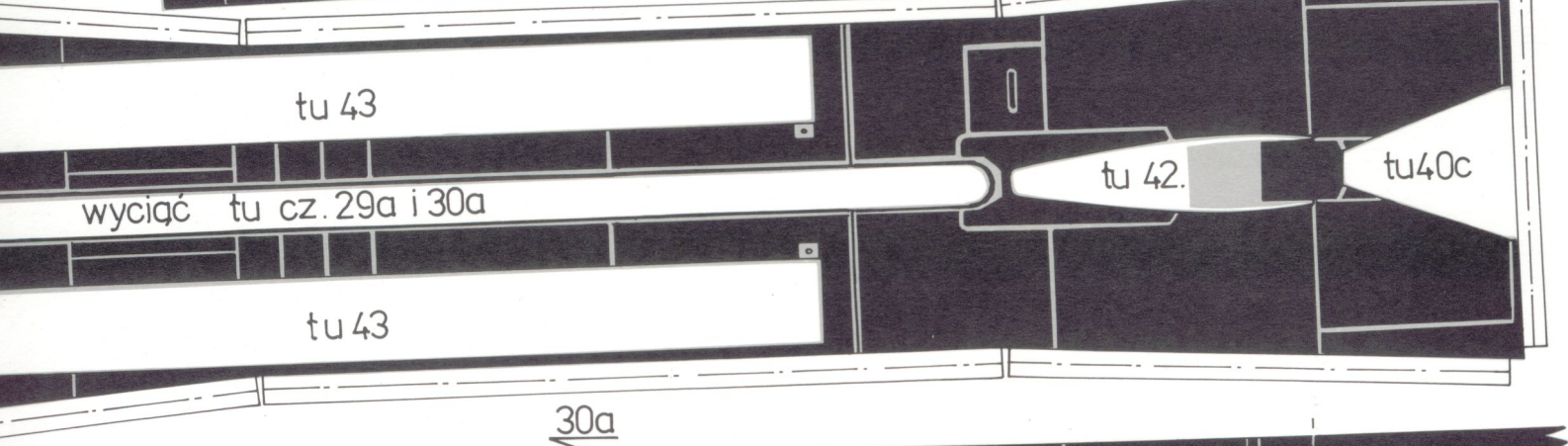
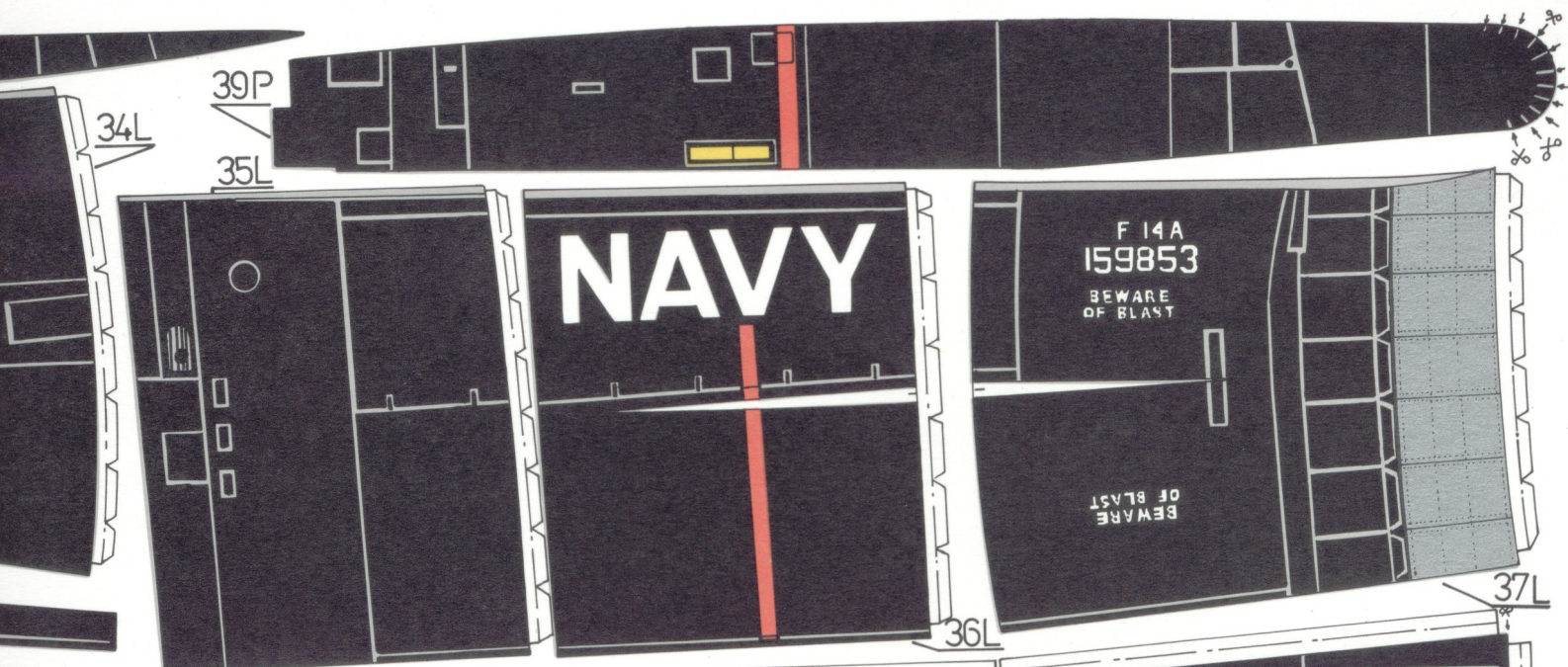

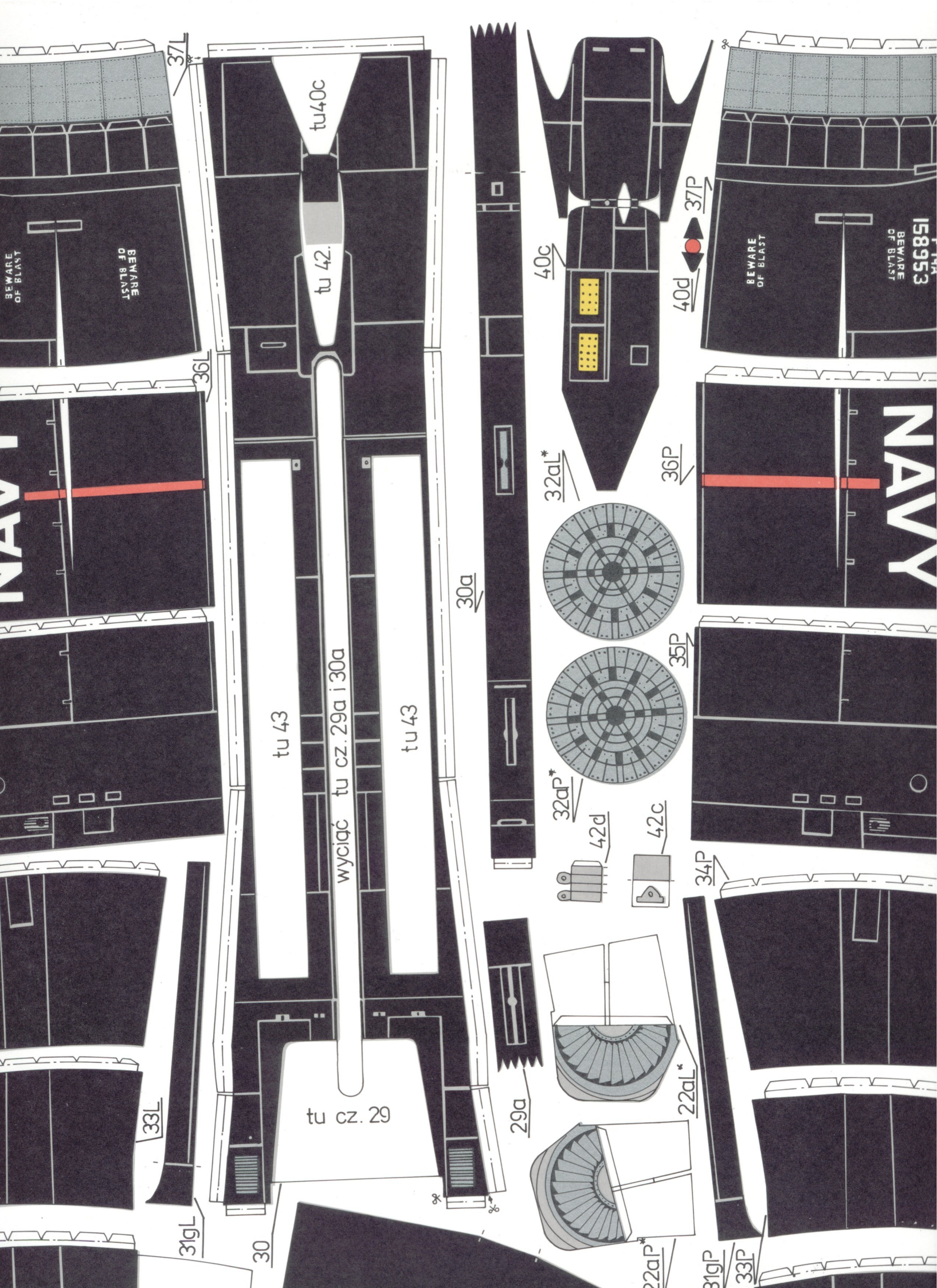

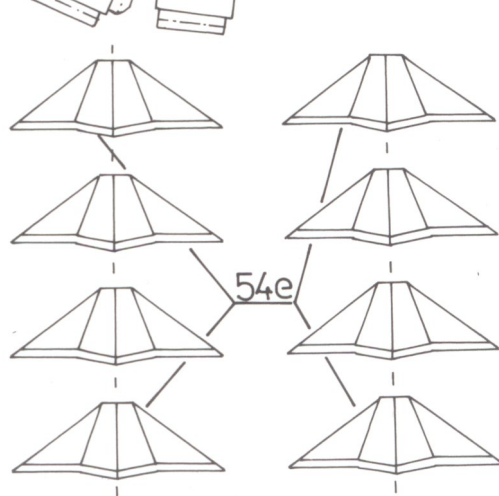
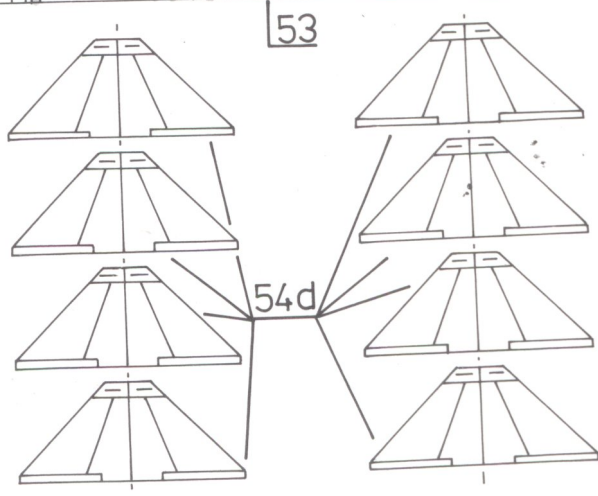
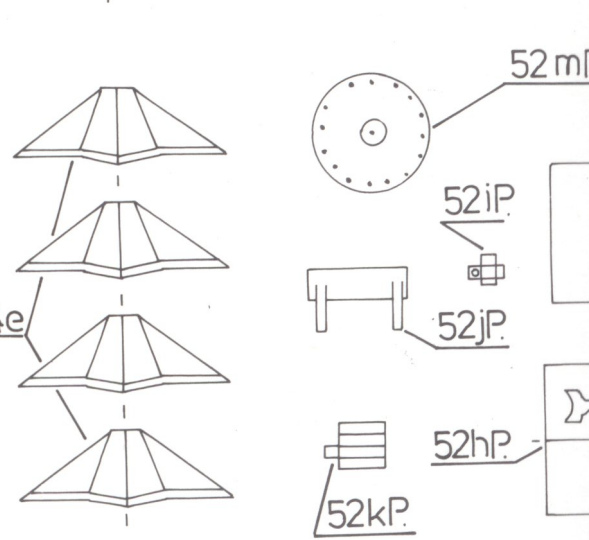
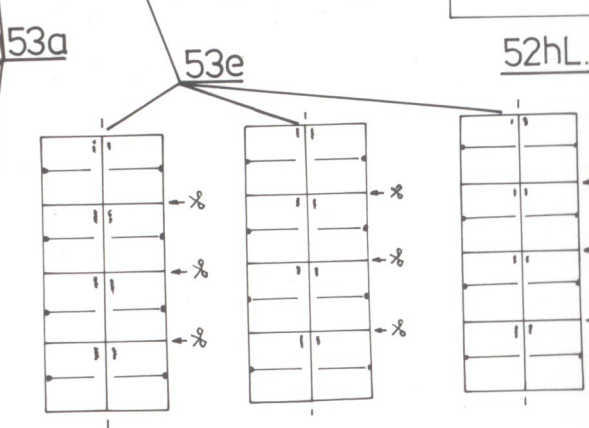
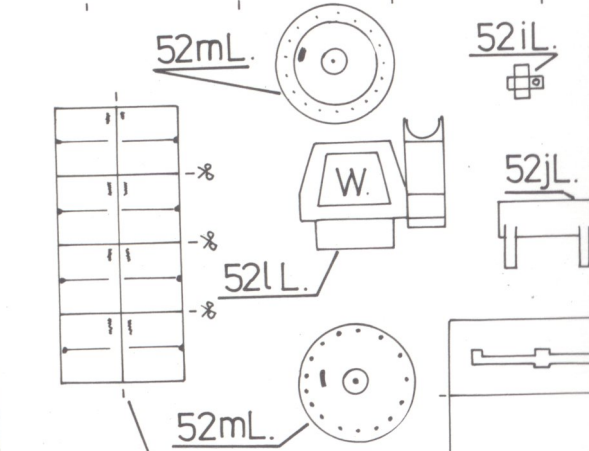
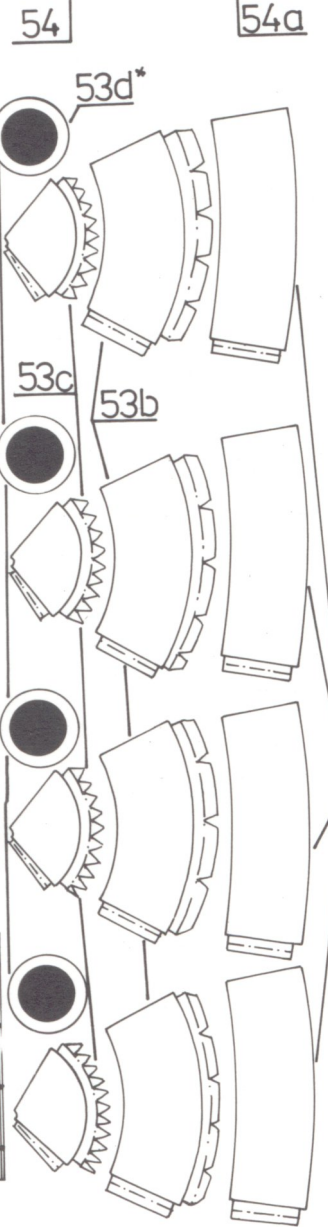
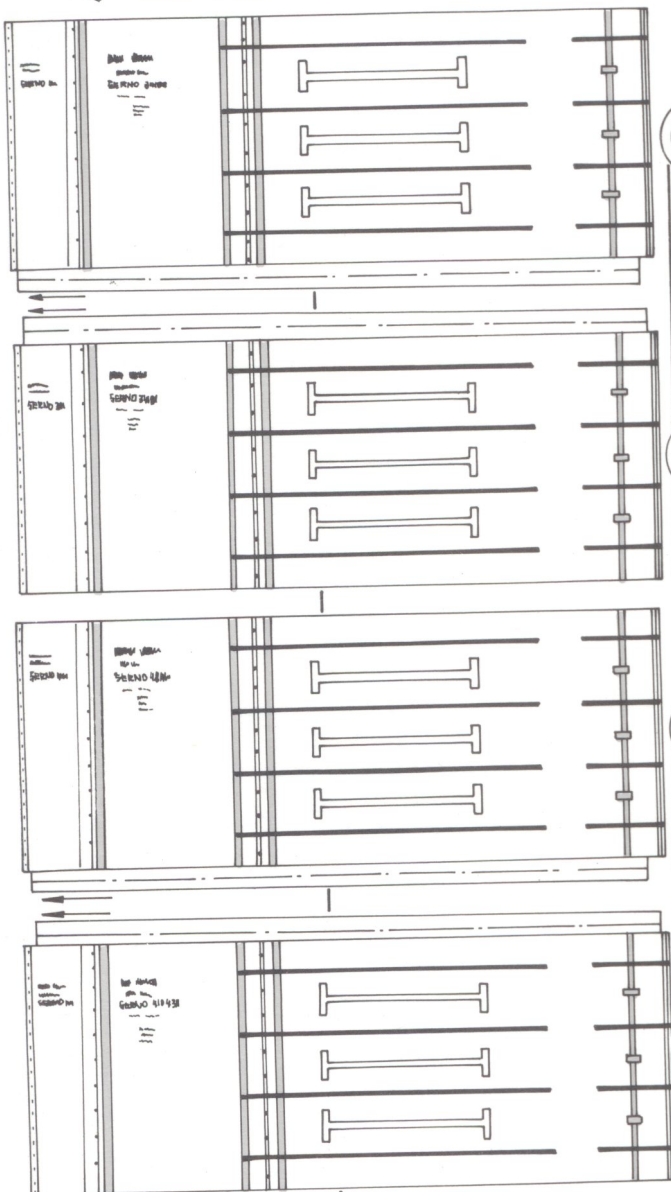
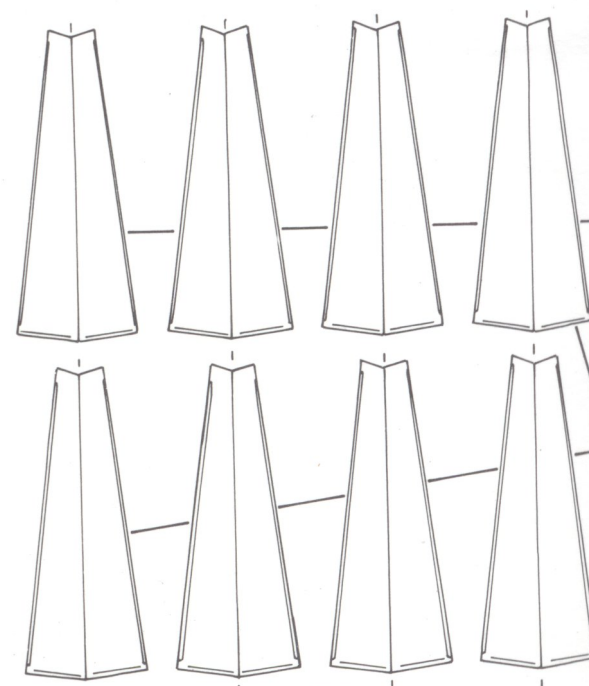

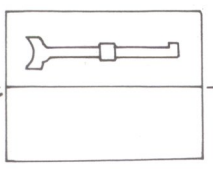
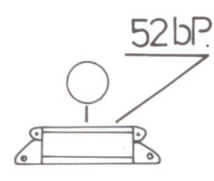
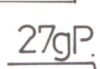
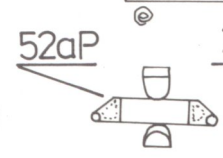
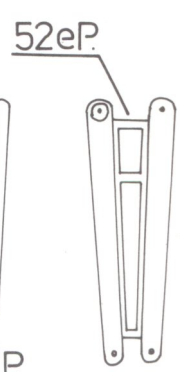
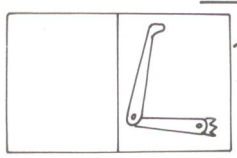
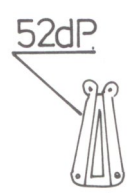
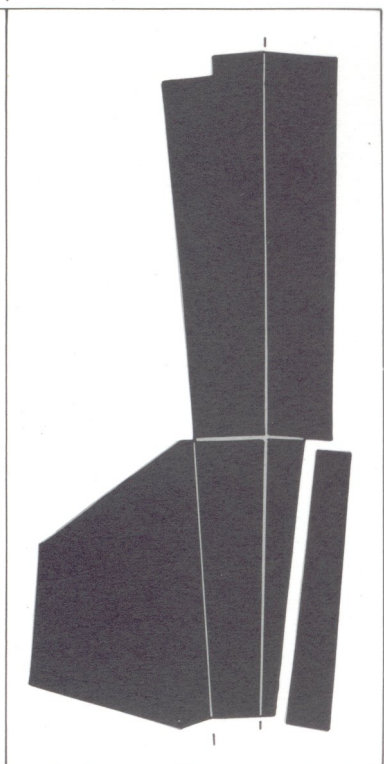
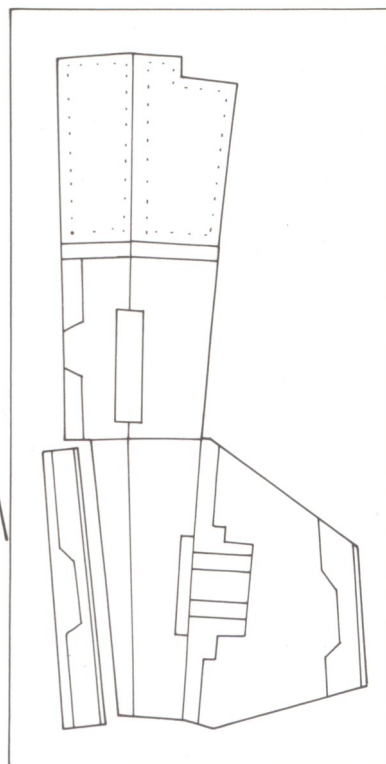
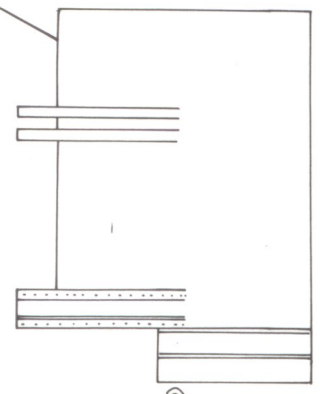
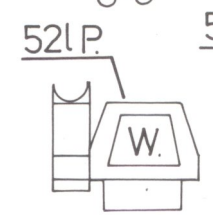
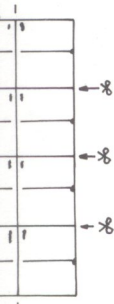
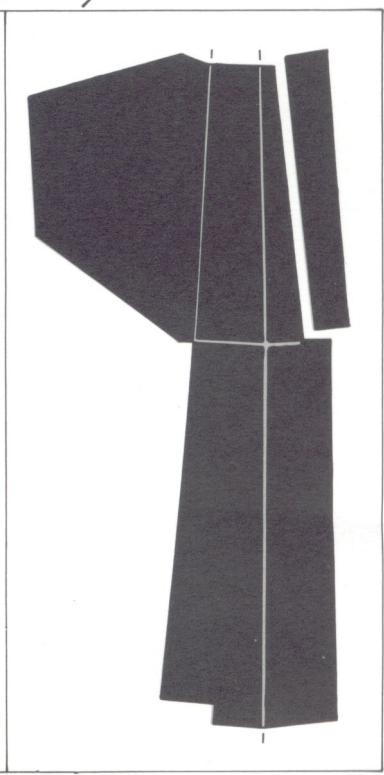
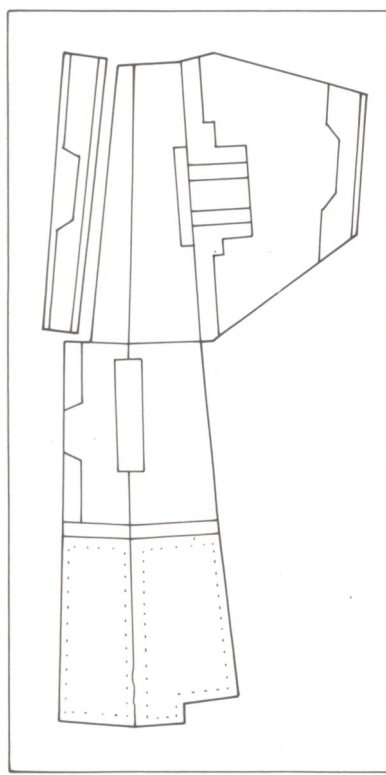
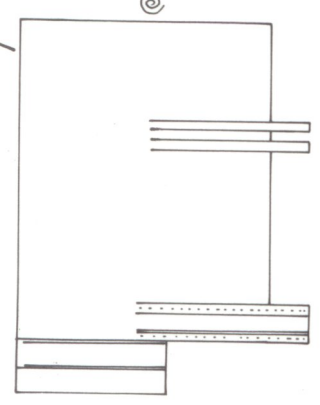
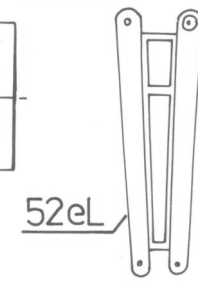
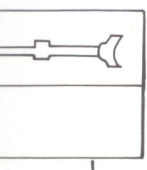
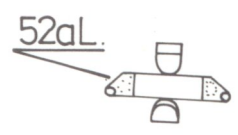
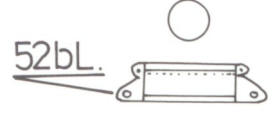
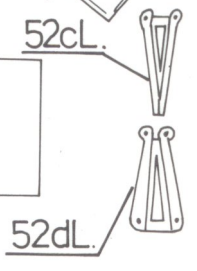
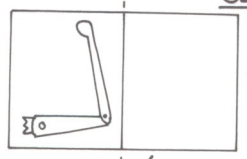
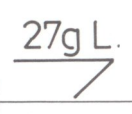
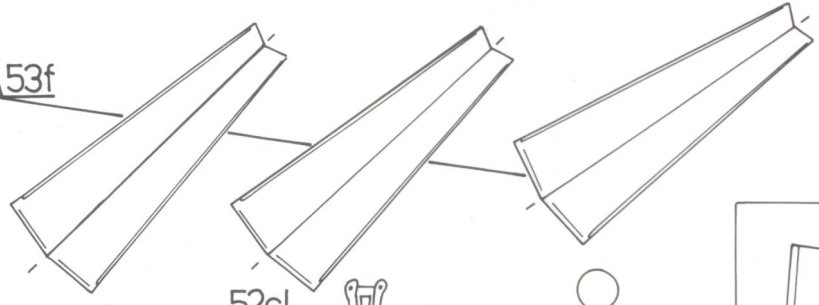
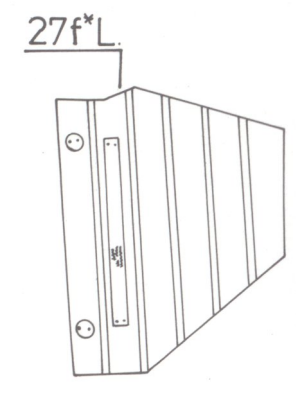
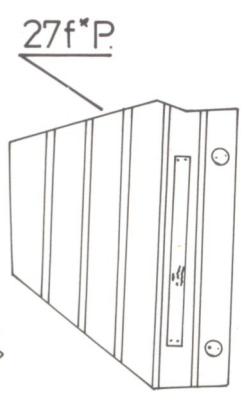
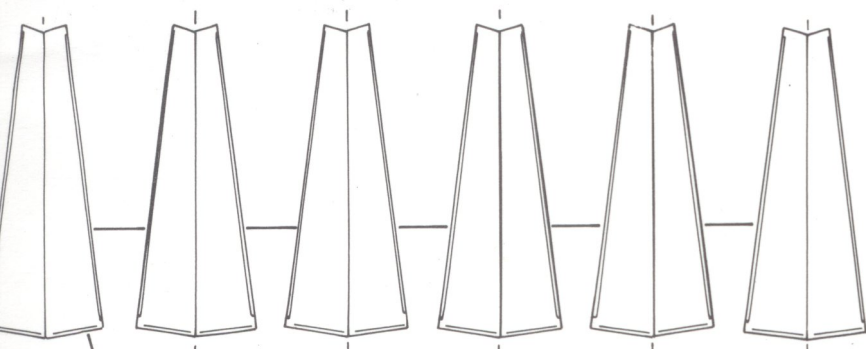

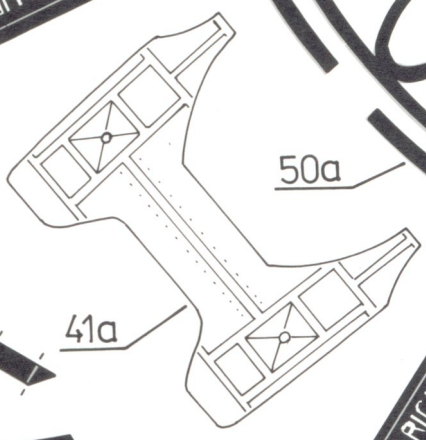
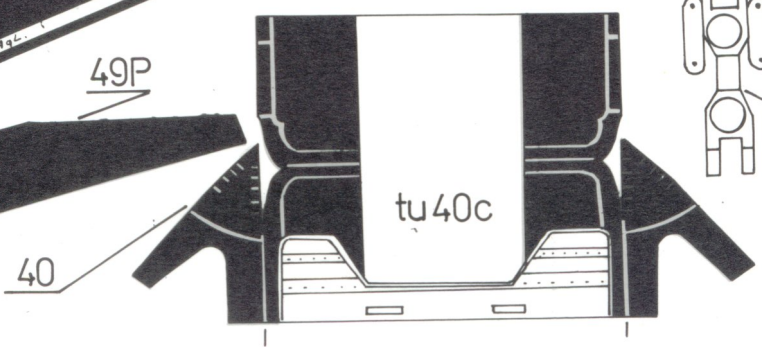
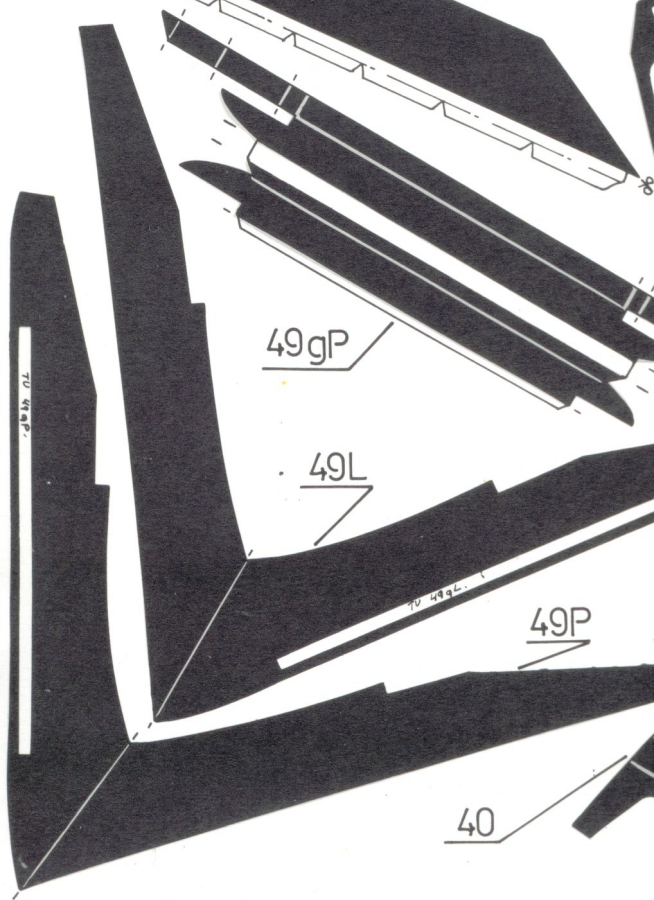
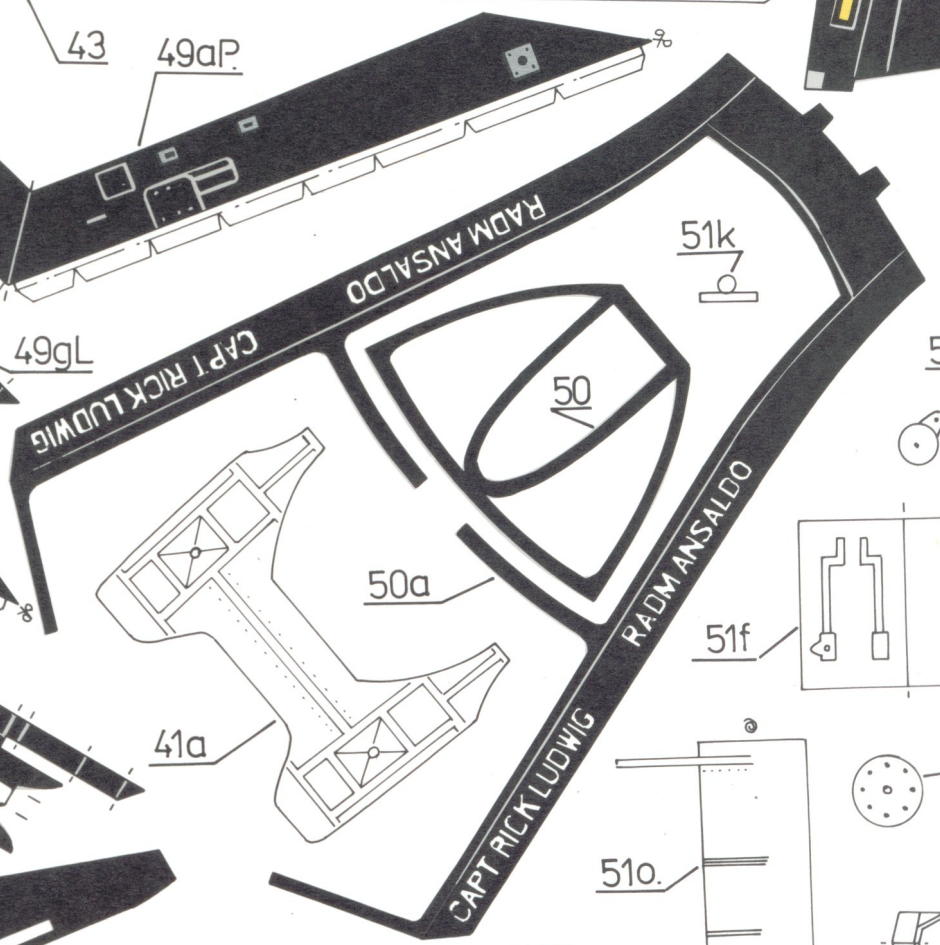
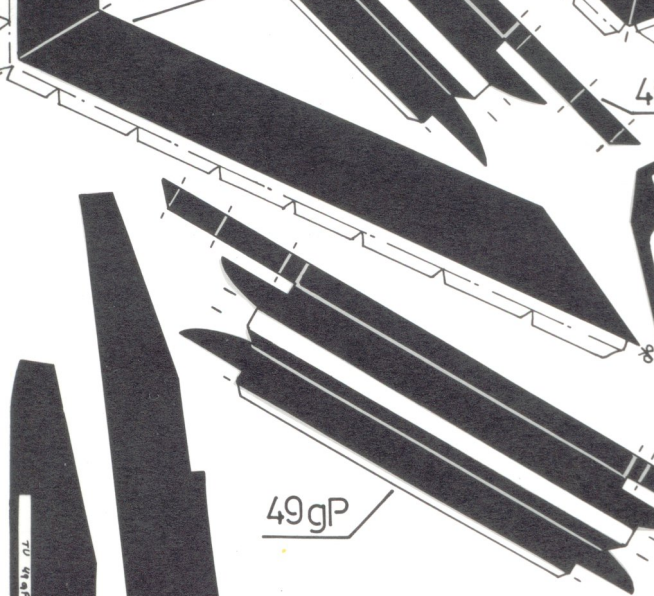
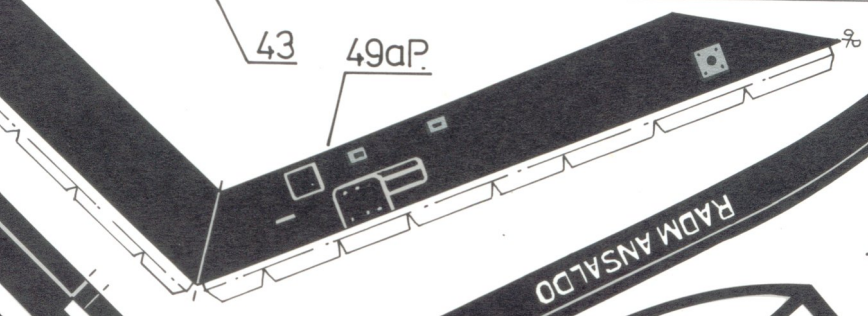
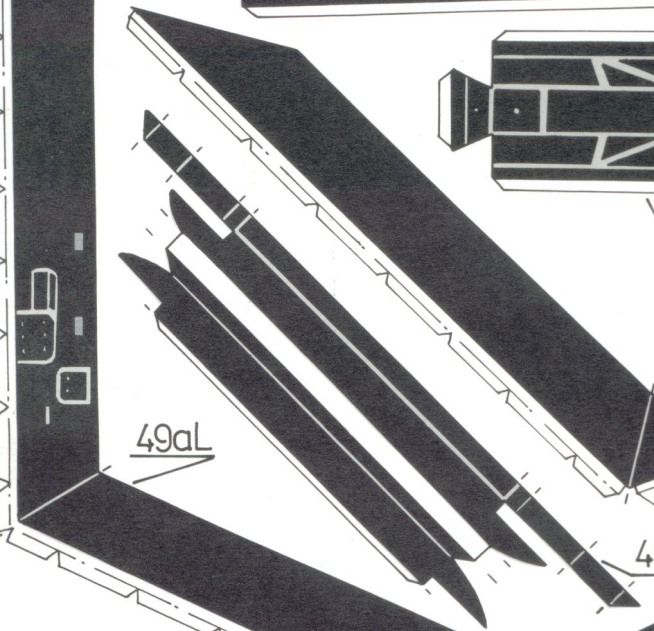
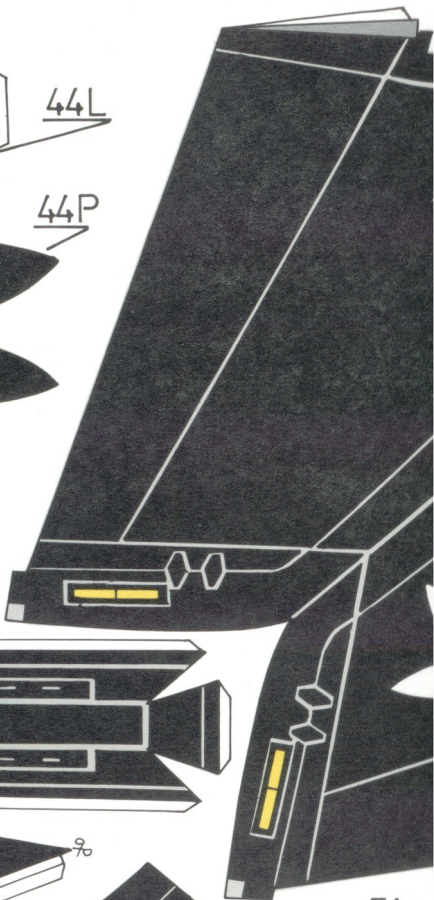
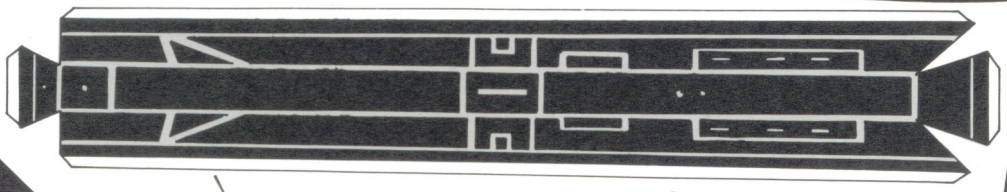
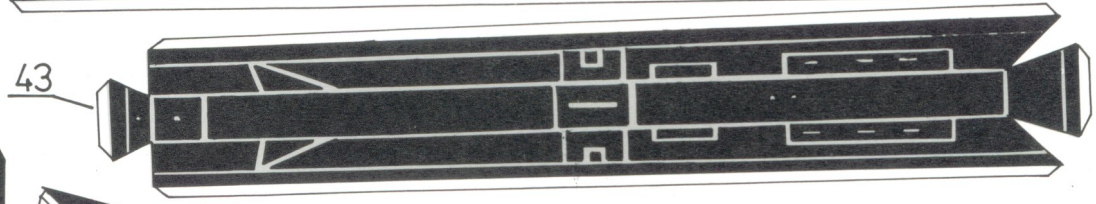
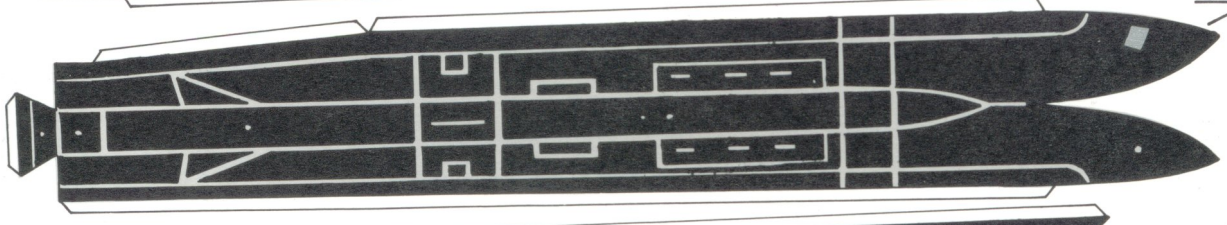
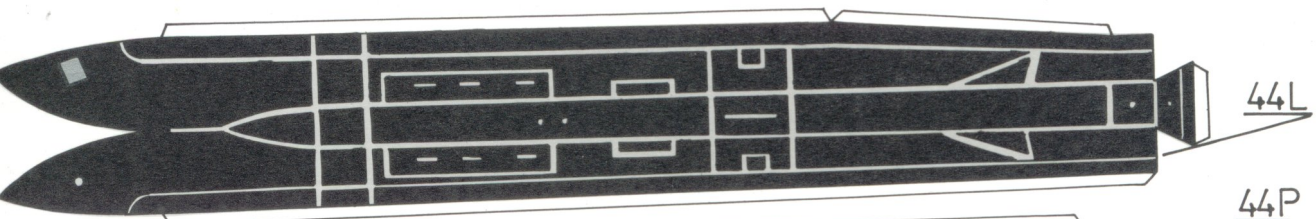

41a

51k

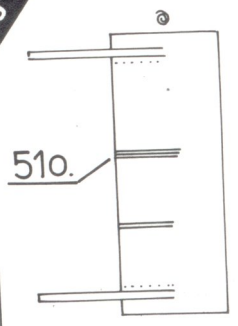
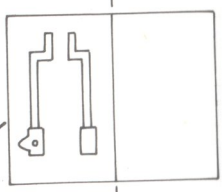
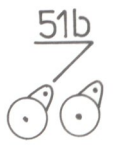

51o

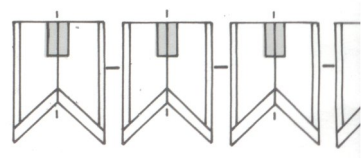



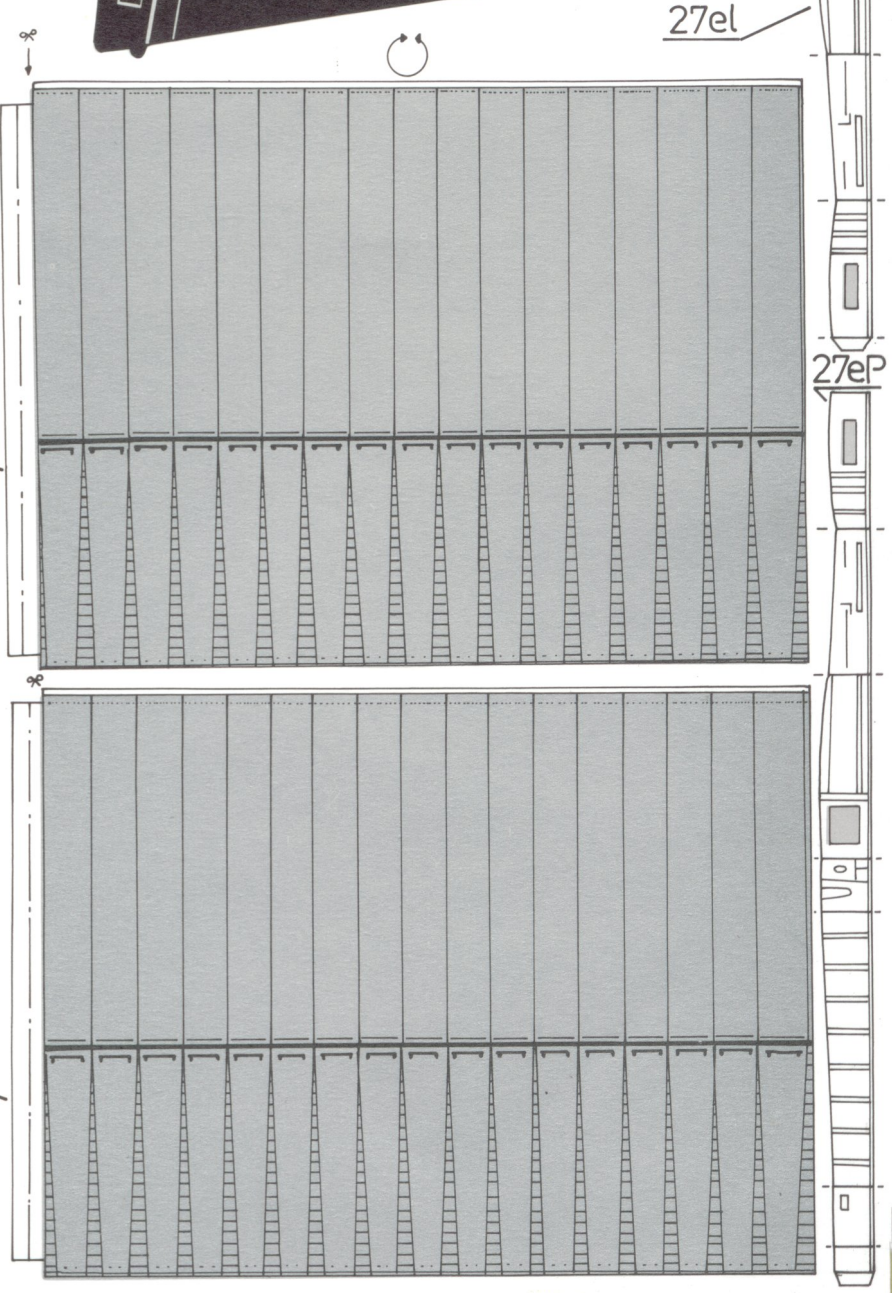
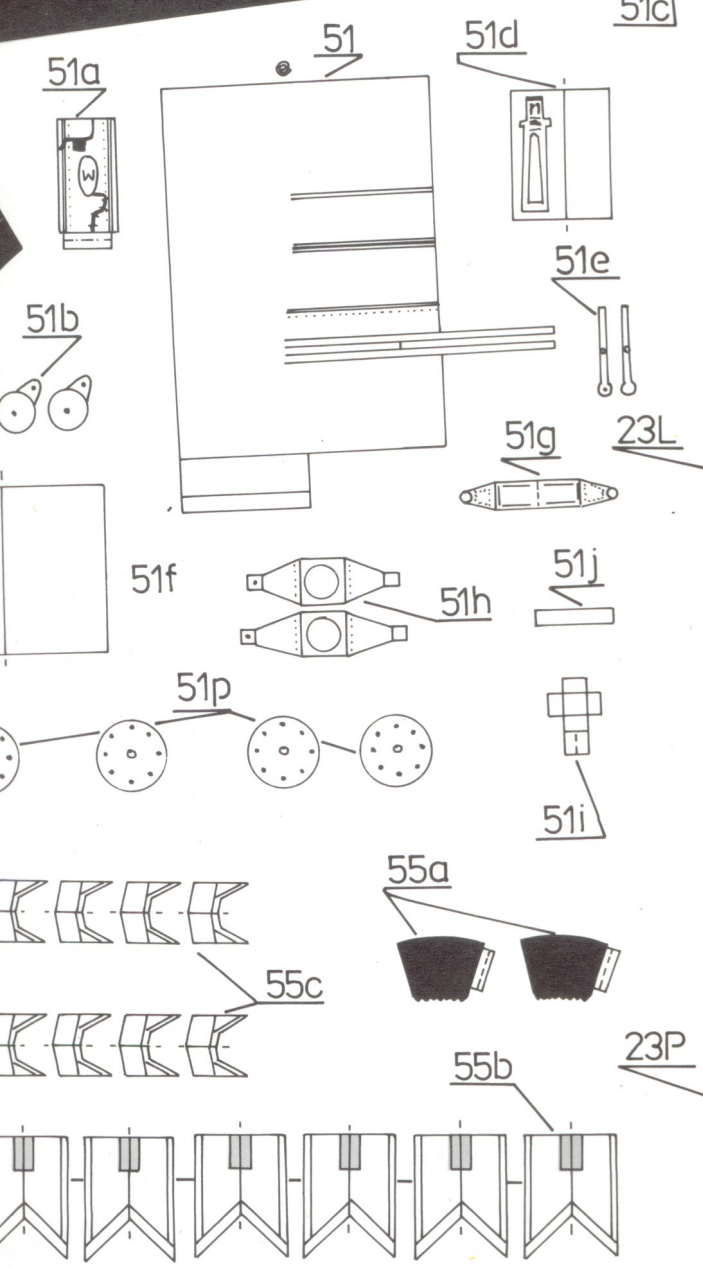
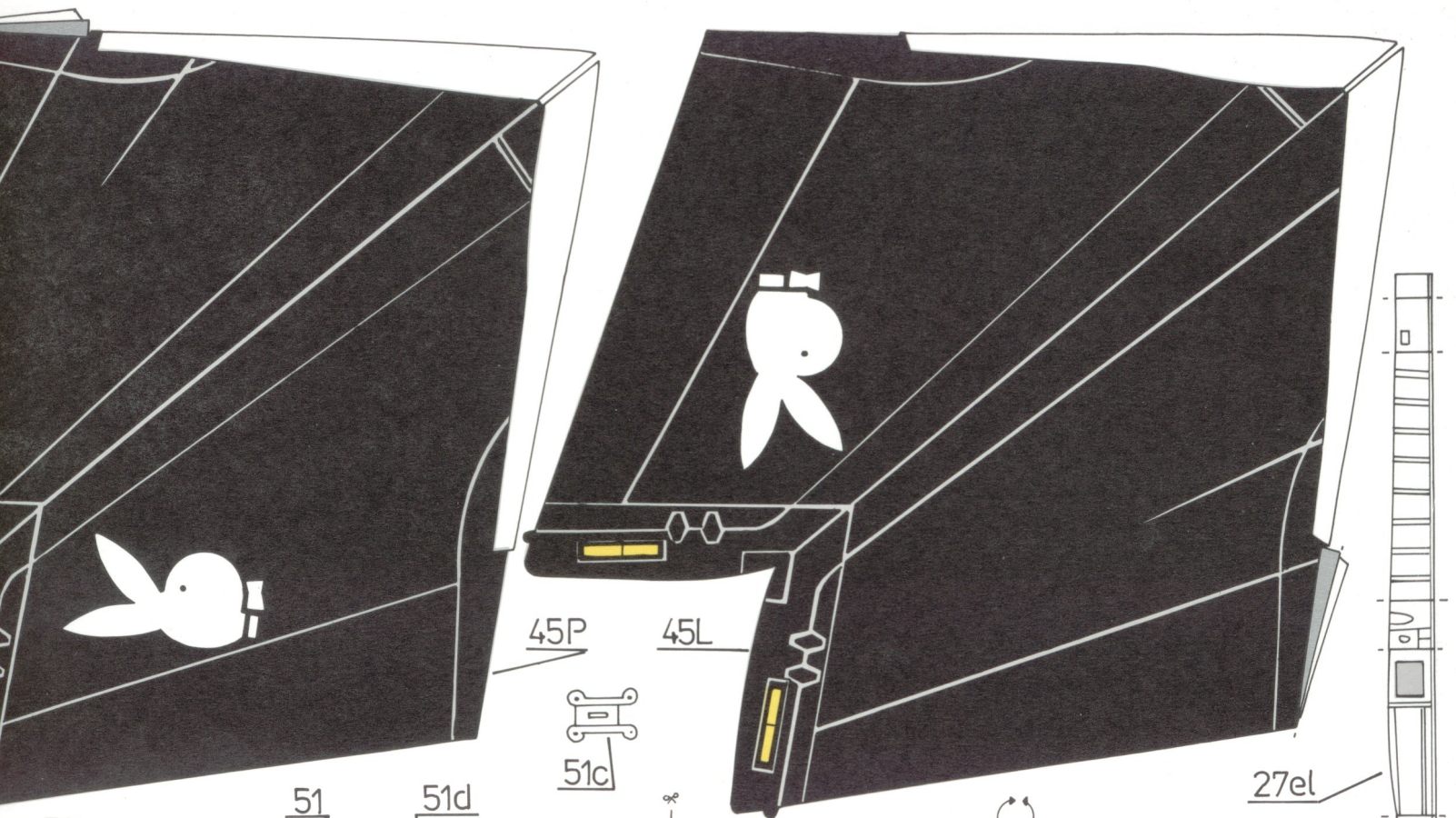



27el

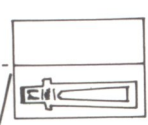
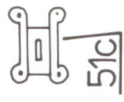
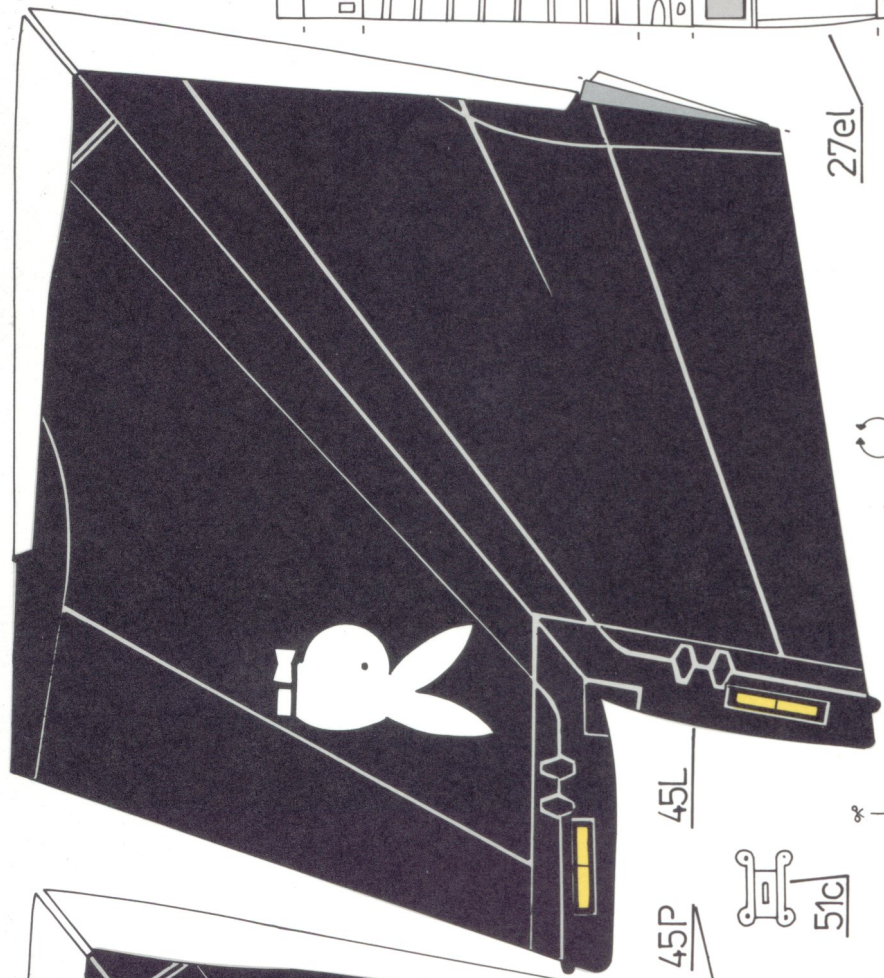
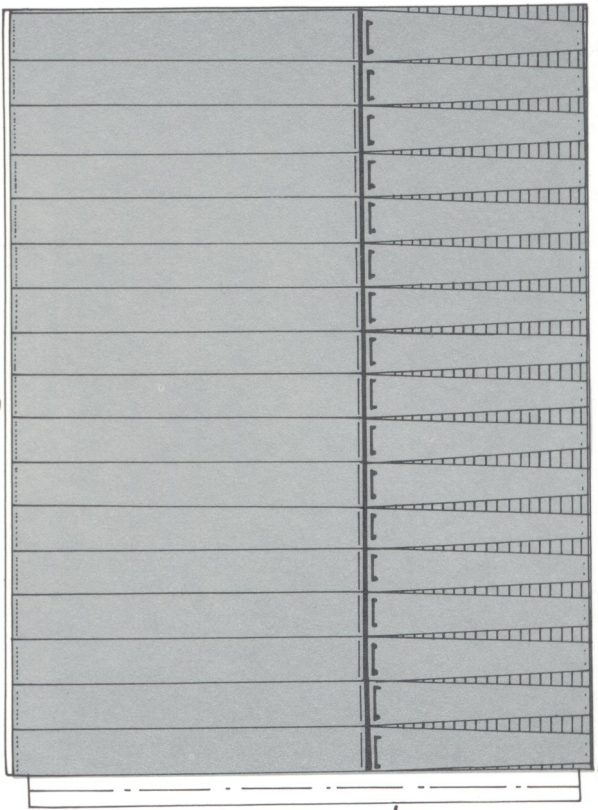

51

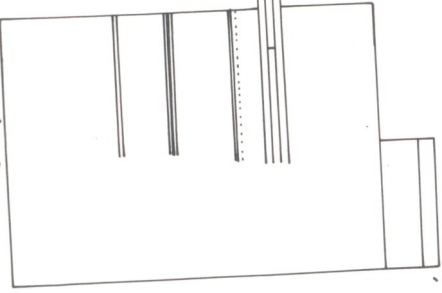

51f

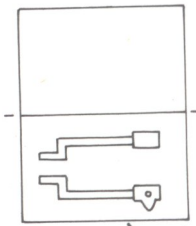

51p

51a

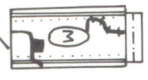

51b



51k



44L

44P

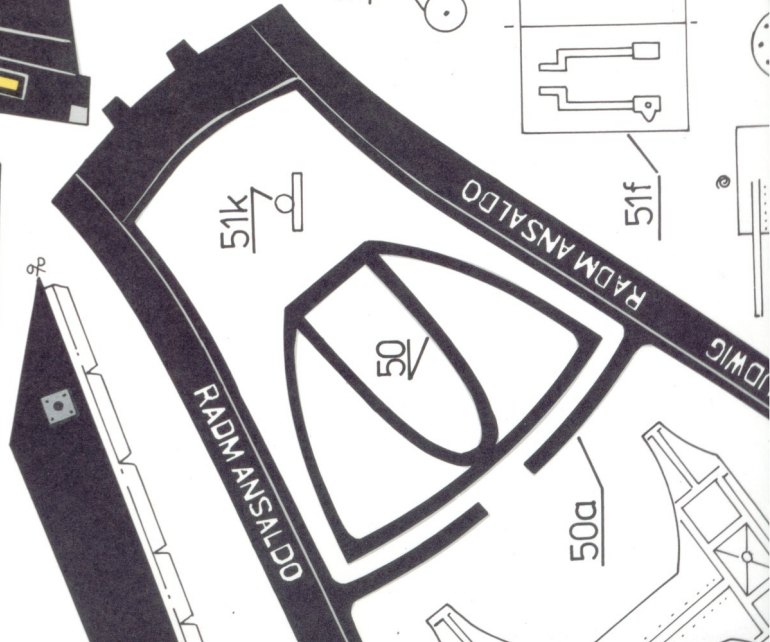
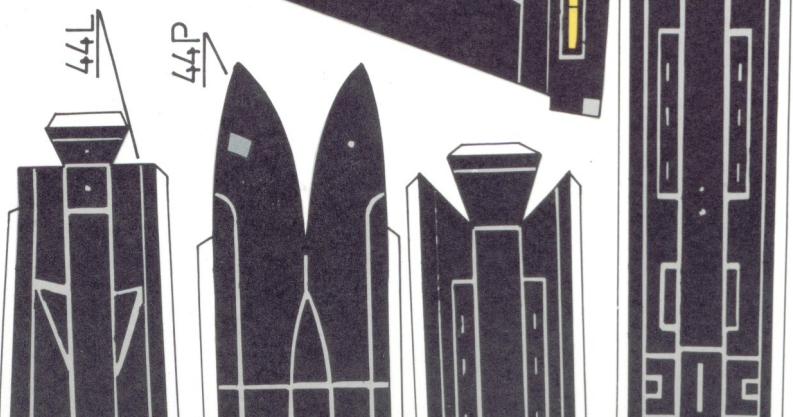

47P

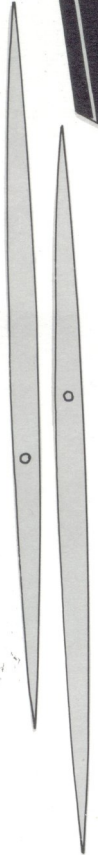
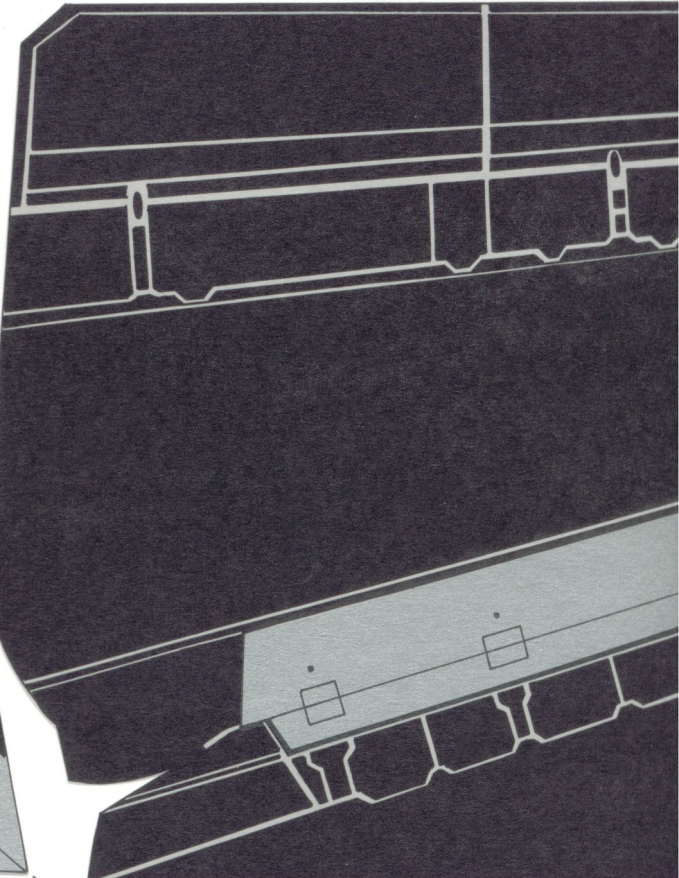
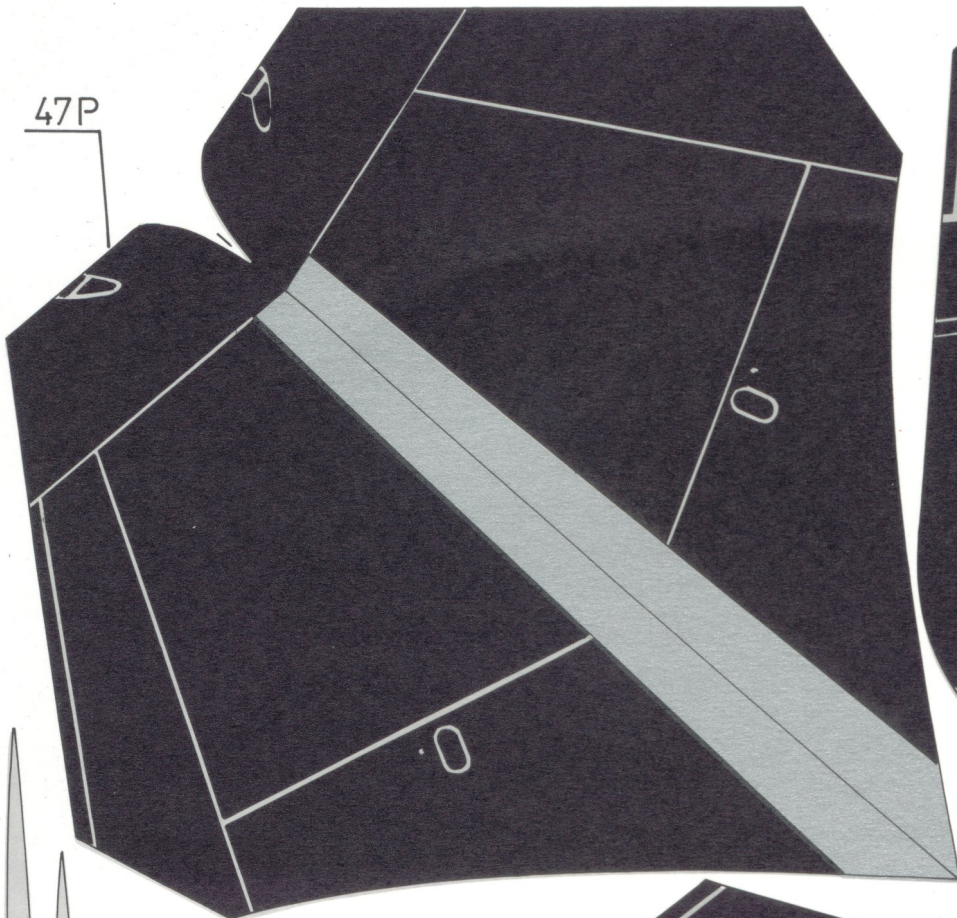

27dP



47L

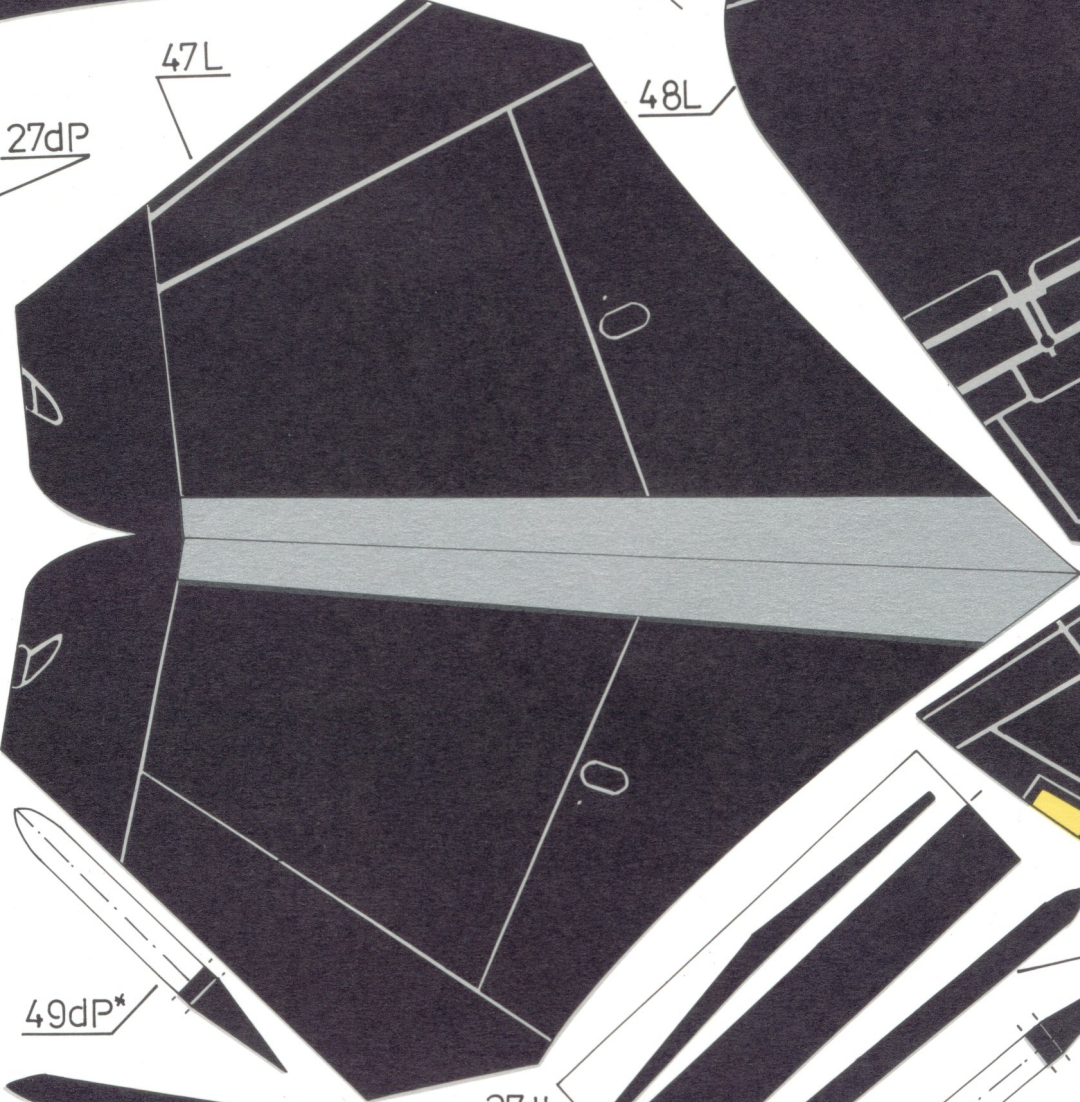

48L

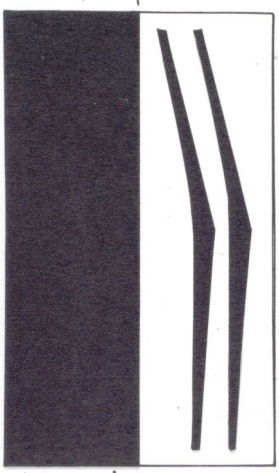

27cL i 27cP

49dP\*

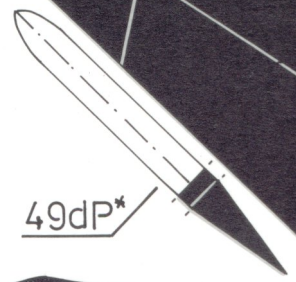

49eL\*



27dL



49eP\*

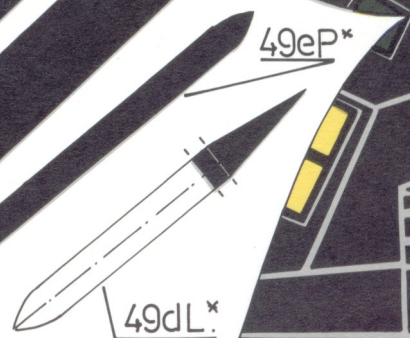

49dL\*



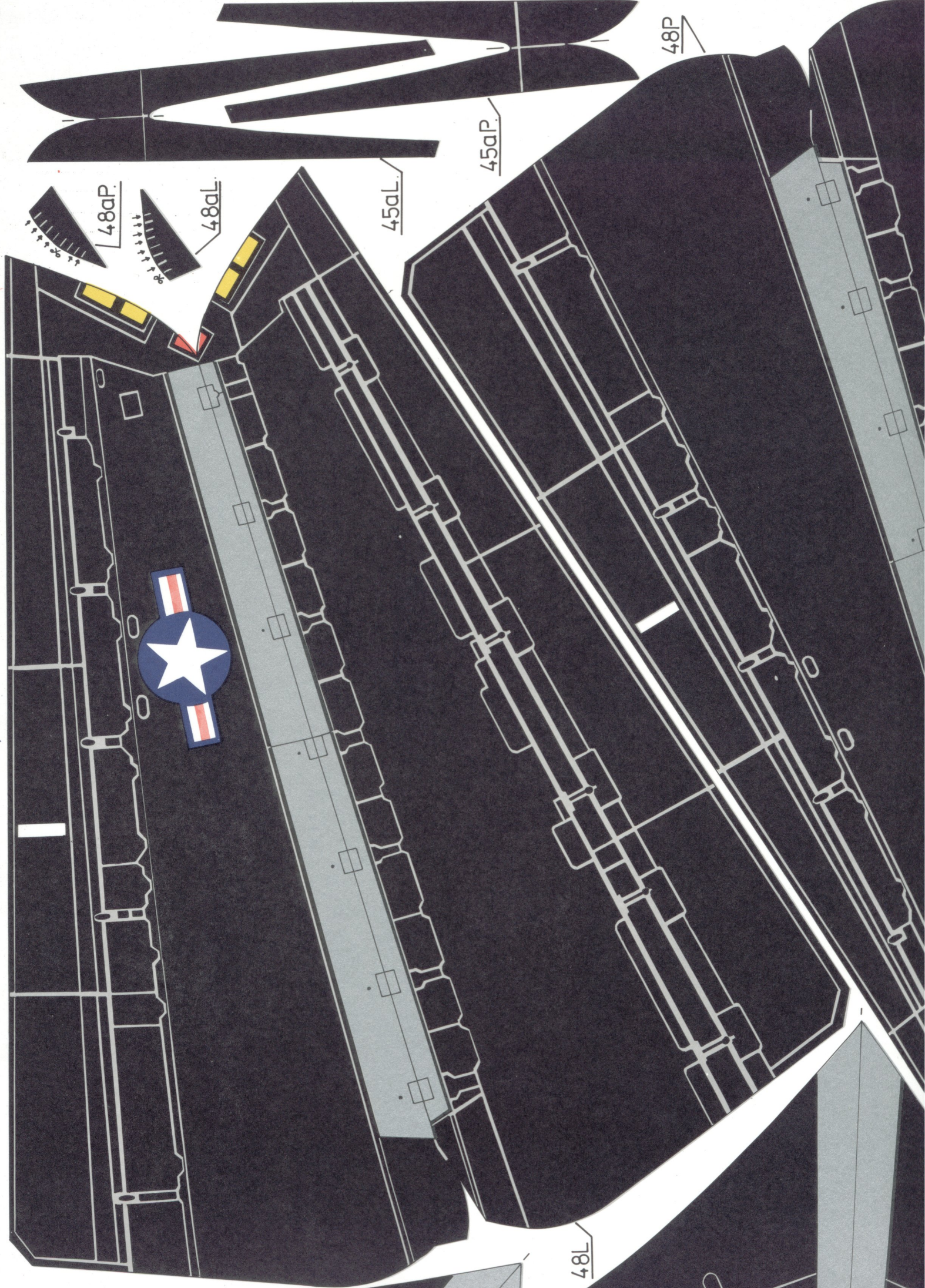

48aP.

48P.

45aL.

45aP.

48P.

48L



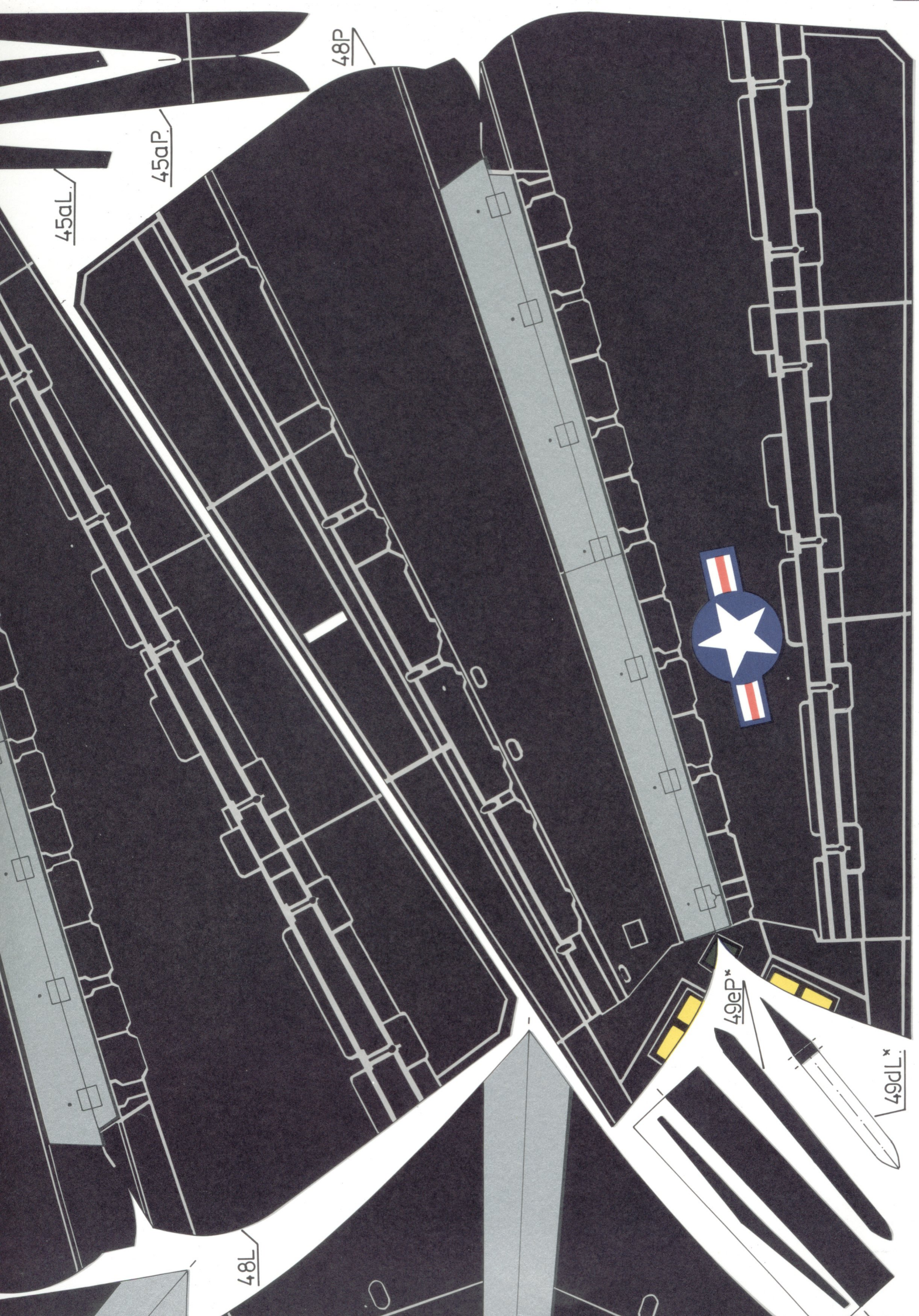

45aL

45aP

48P

48L

49eP\*

71p67

49eP\*

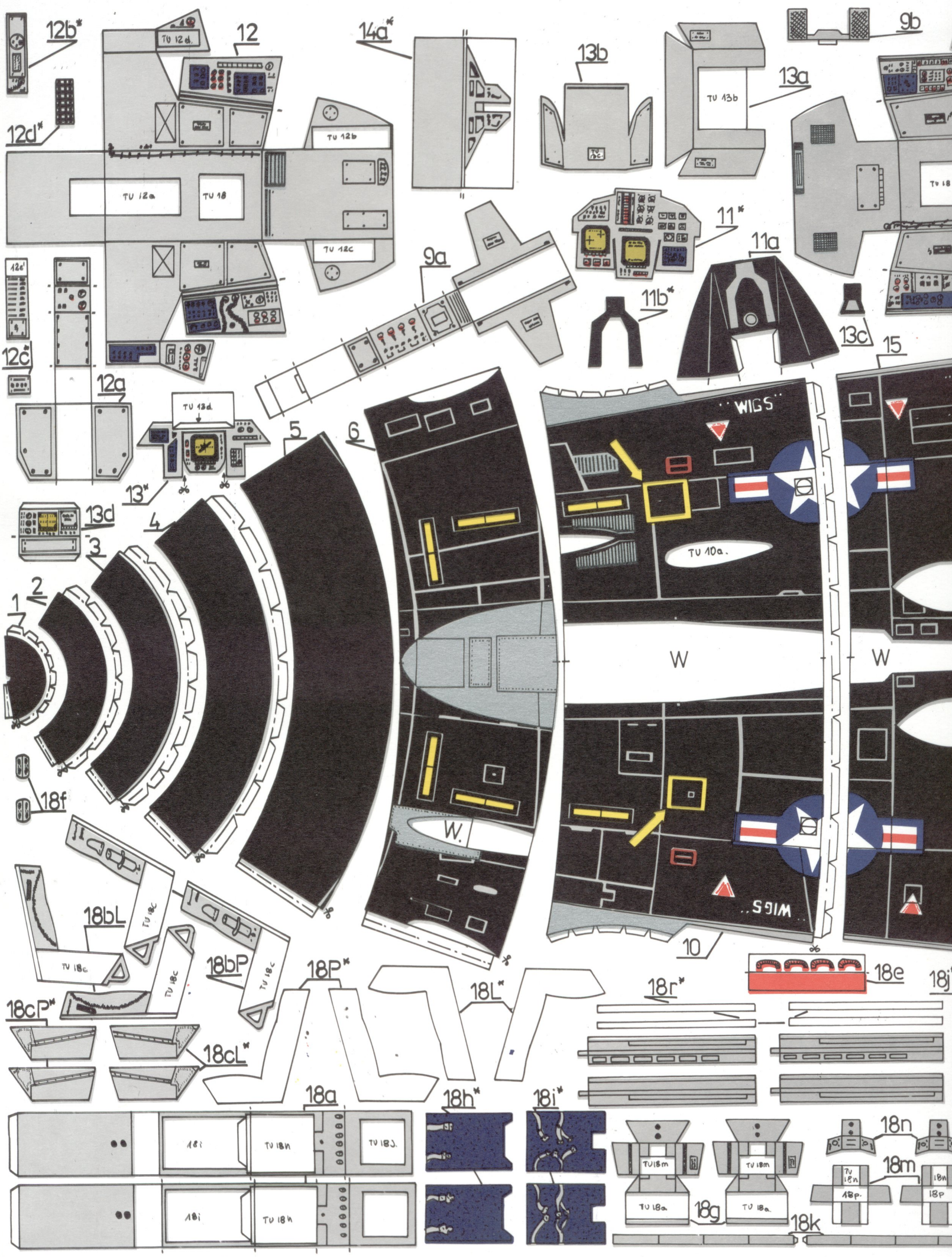

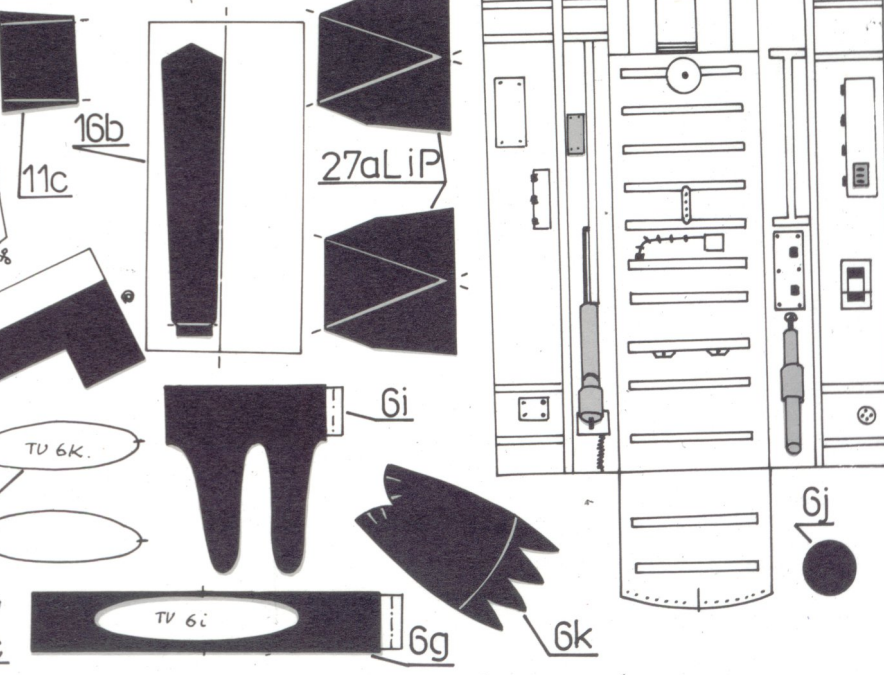
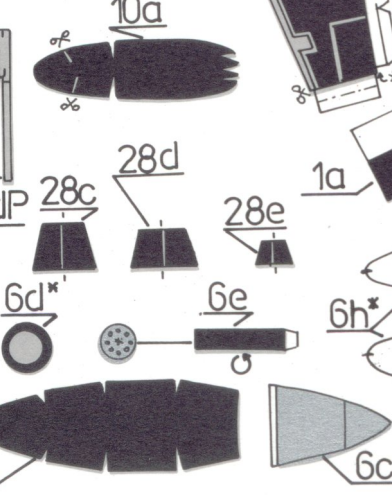
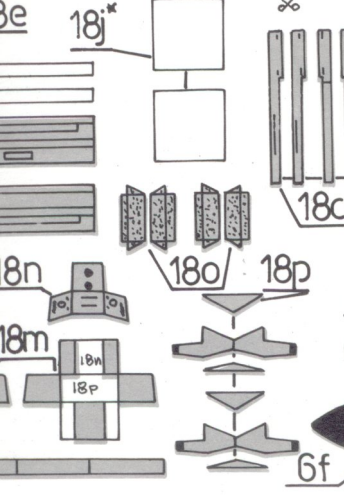
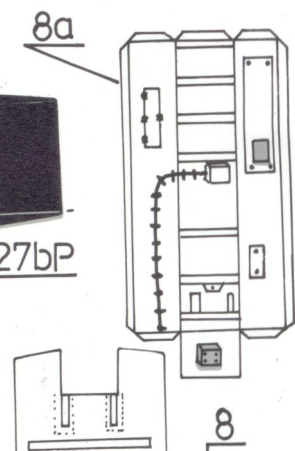
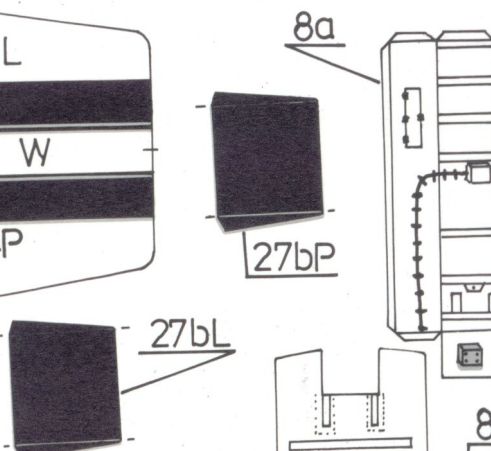
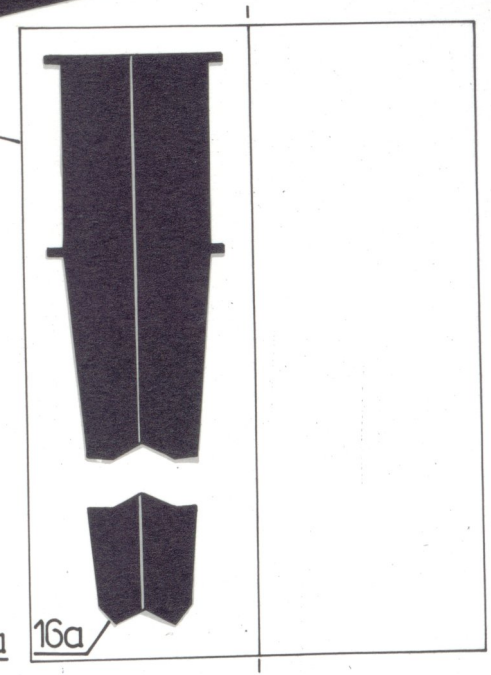
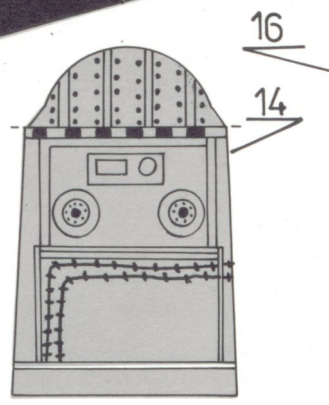
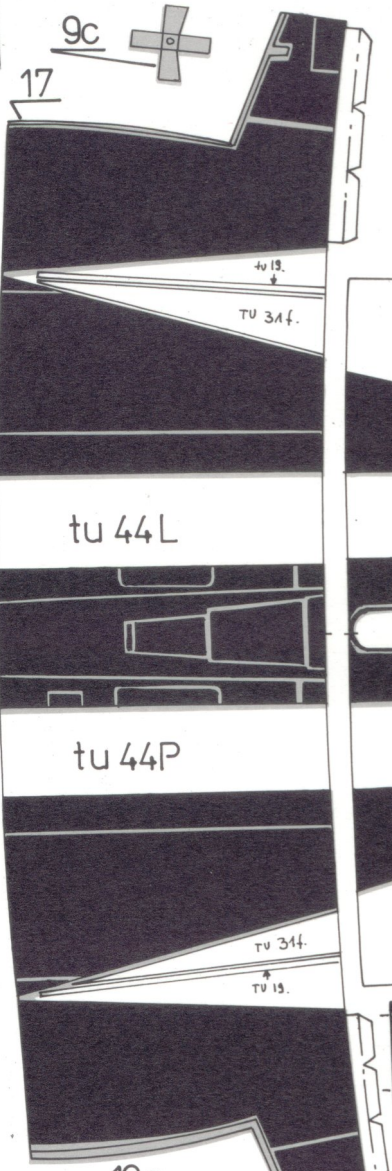
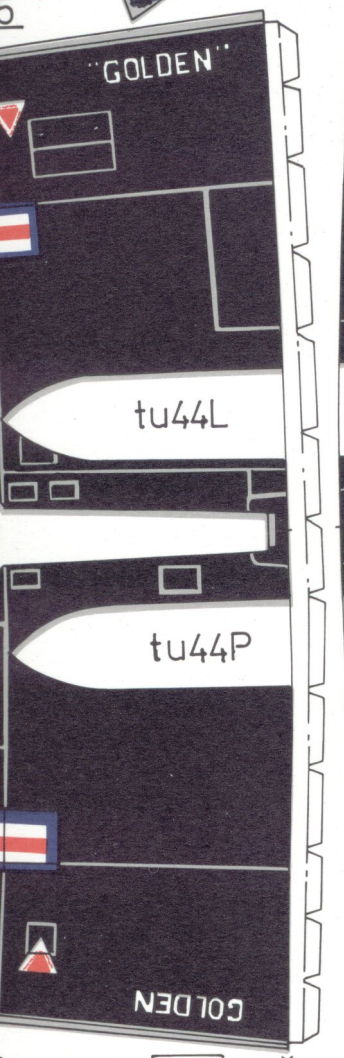
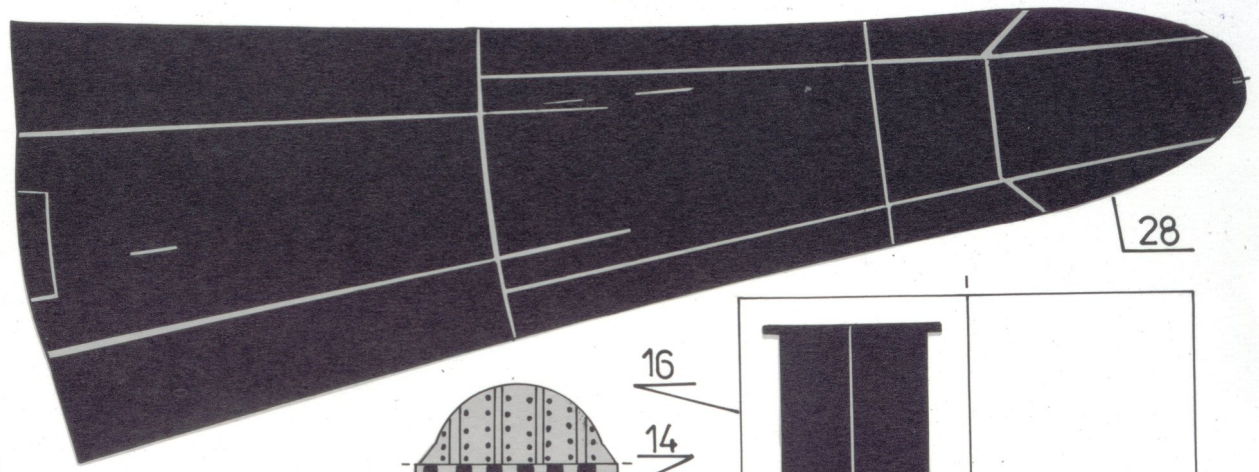
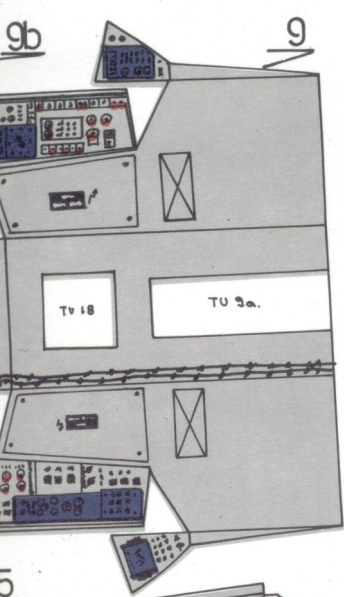
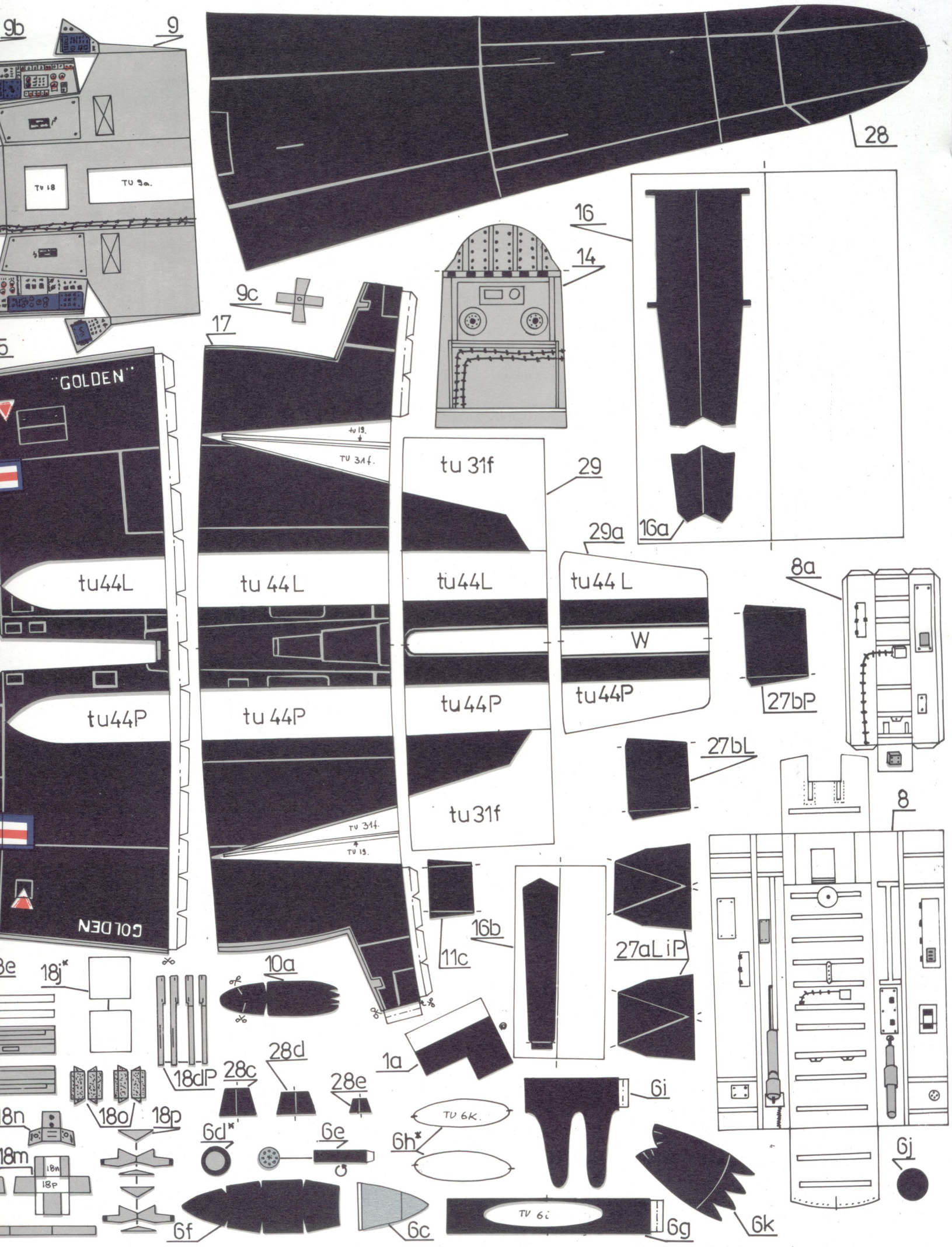





RYS. 1

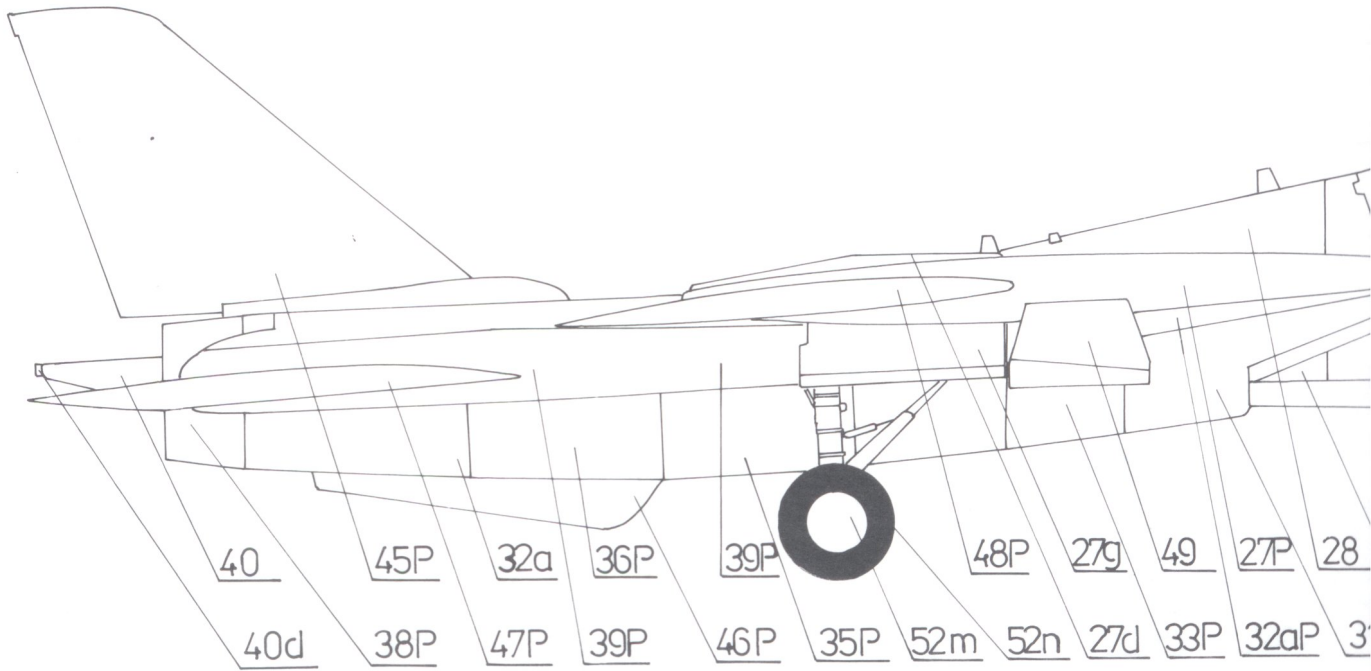
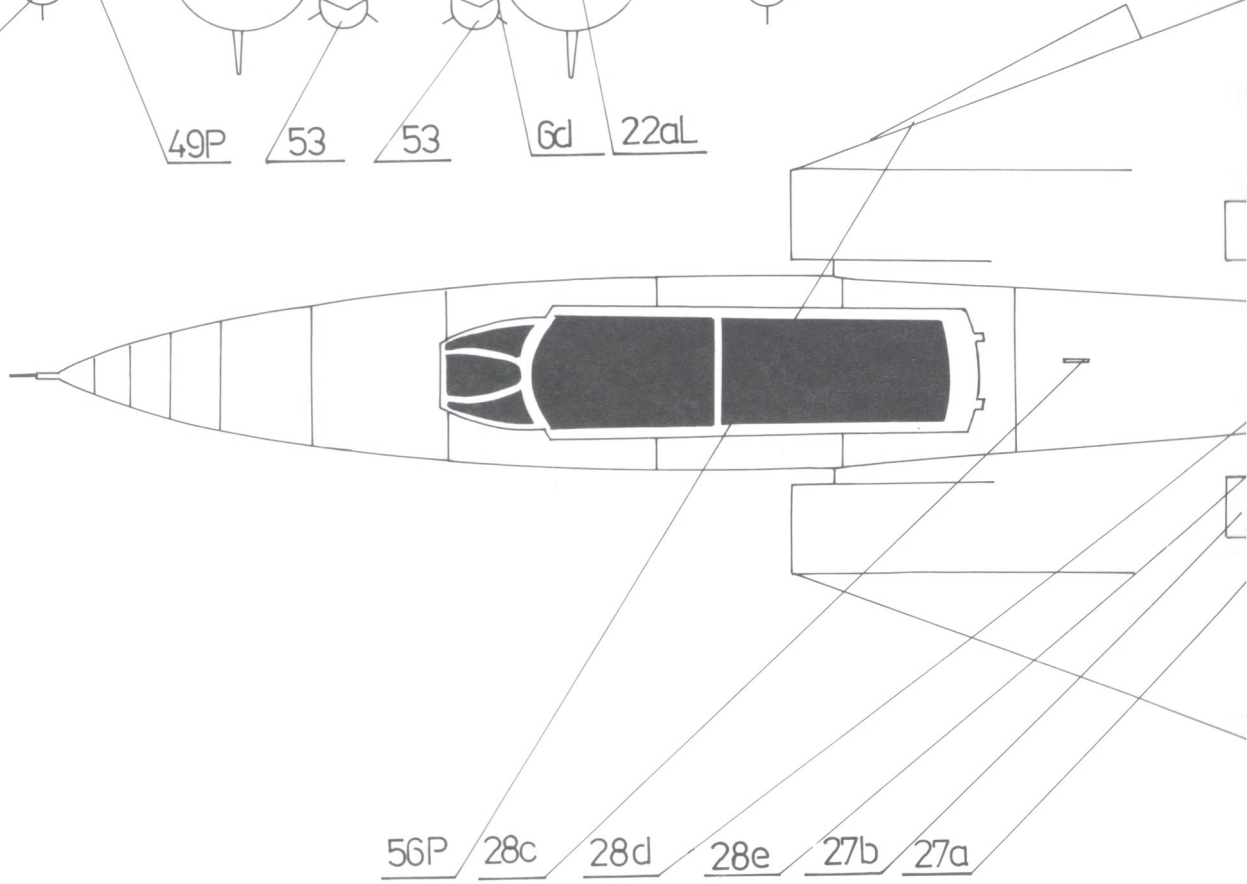
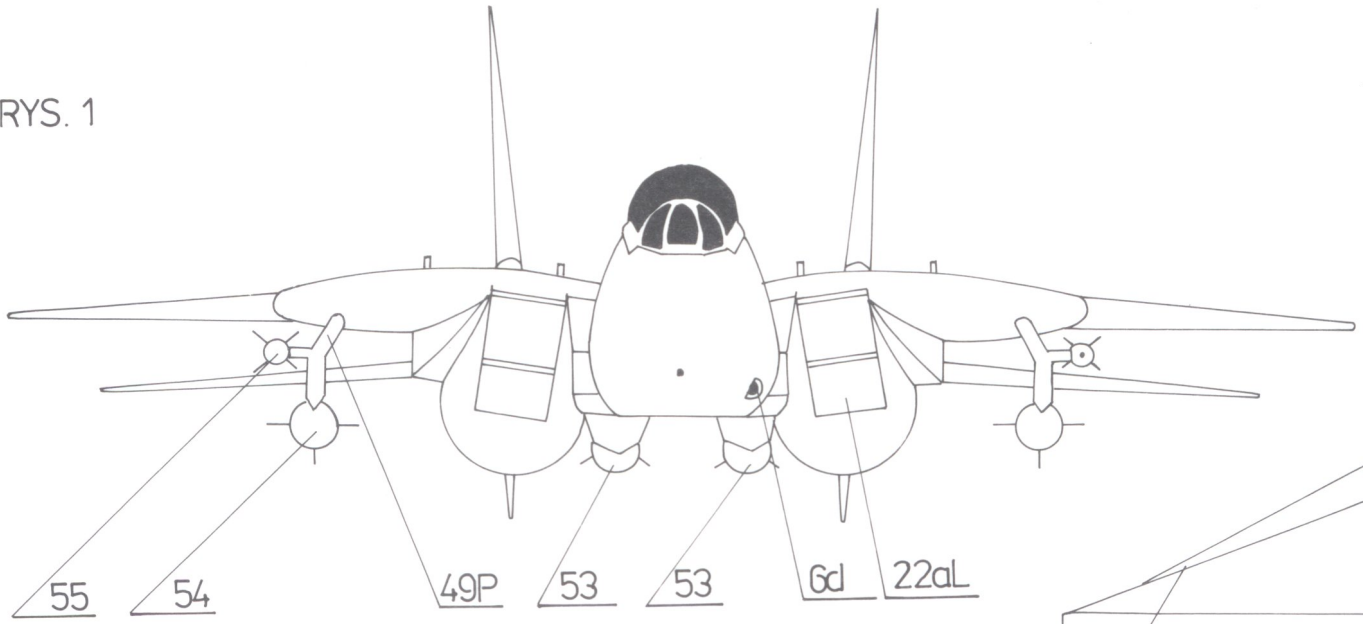

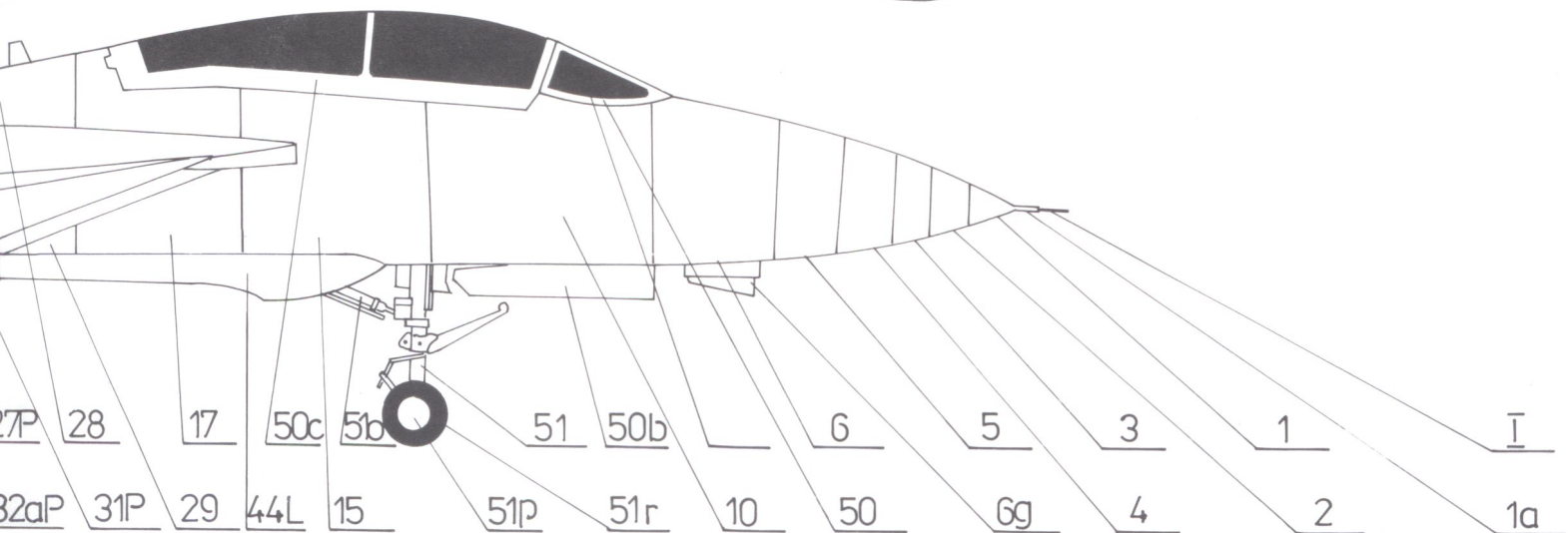
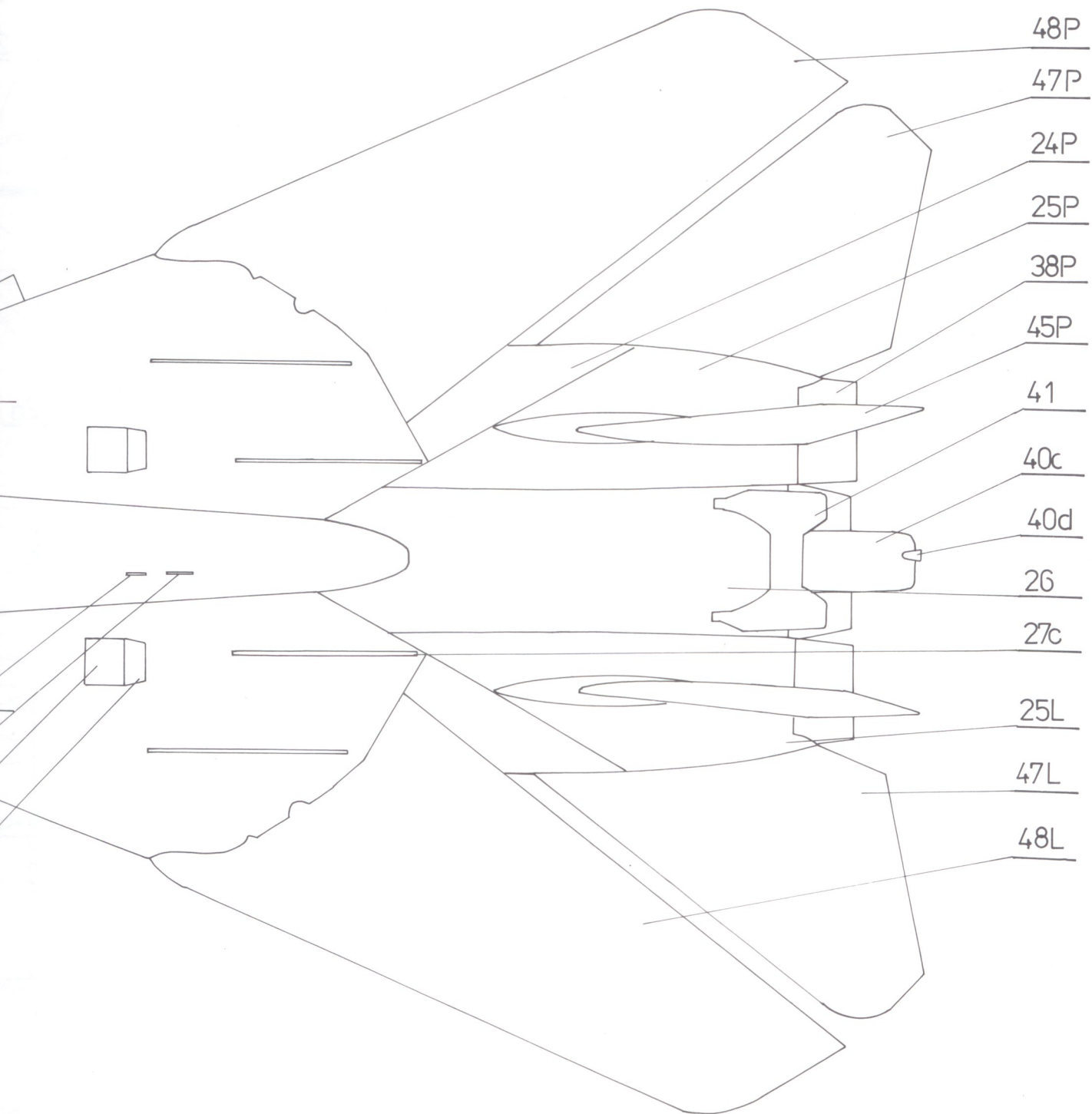

RYS. 2

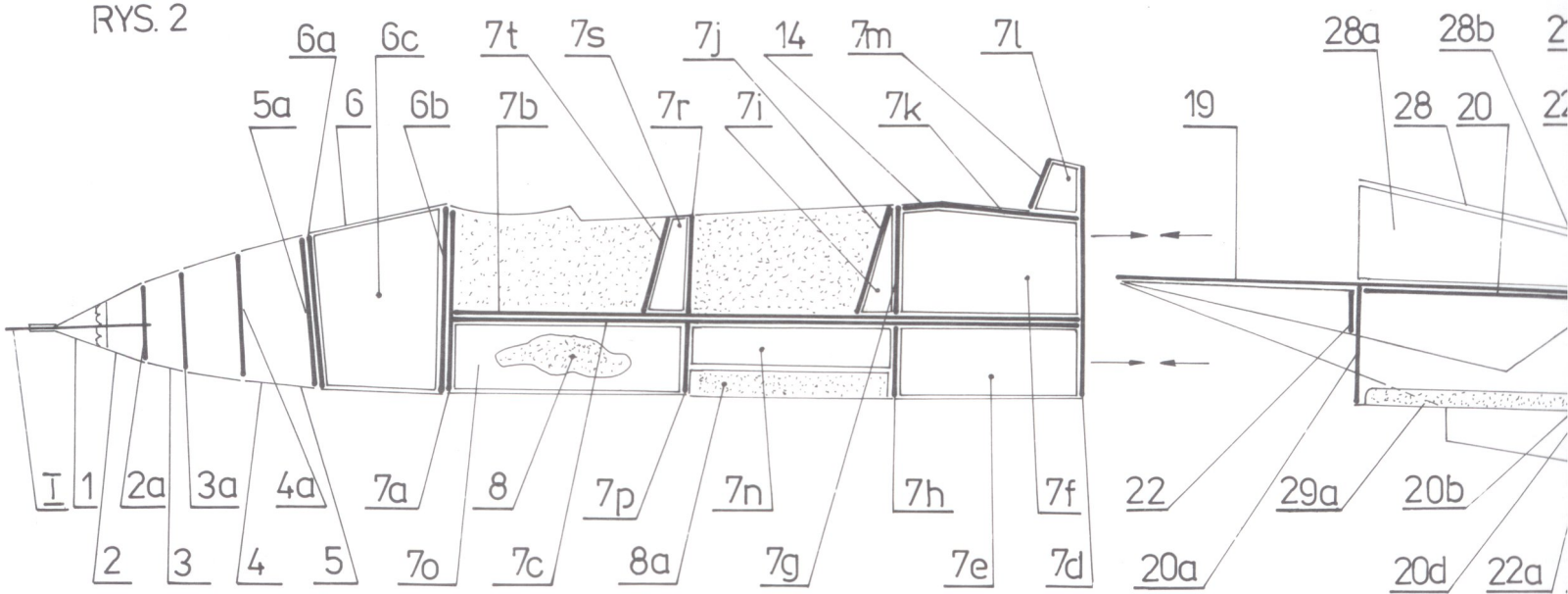

RYS. 5.

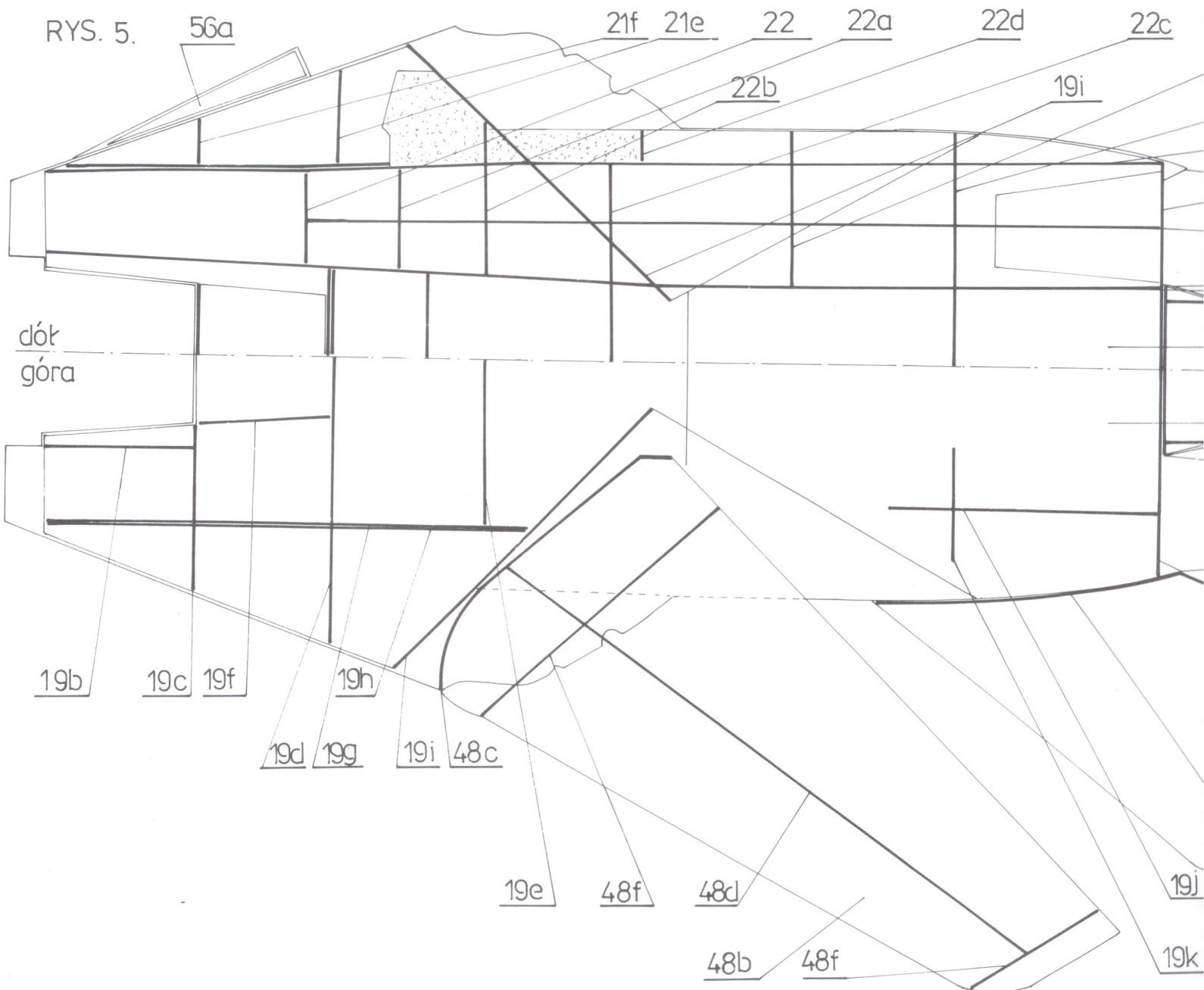

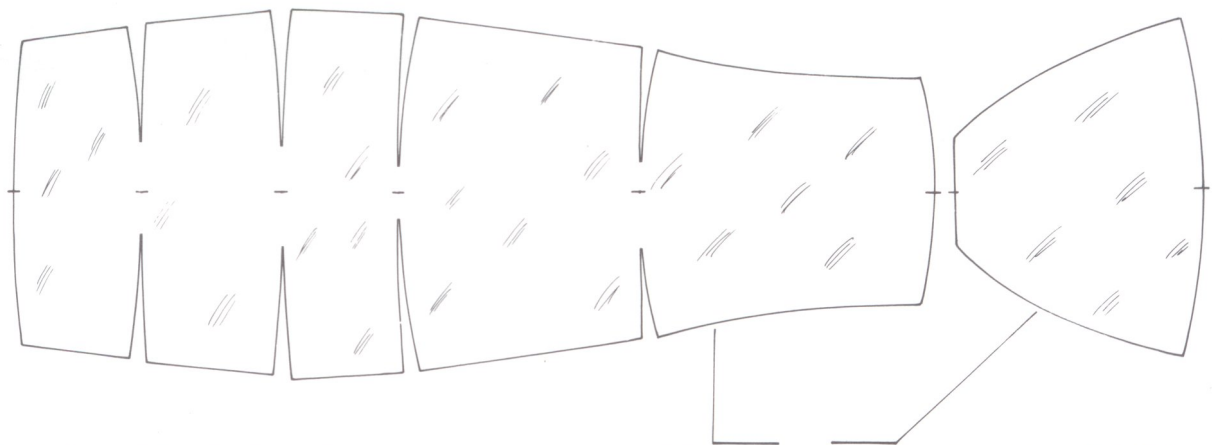
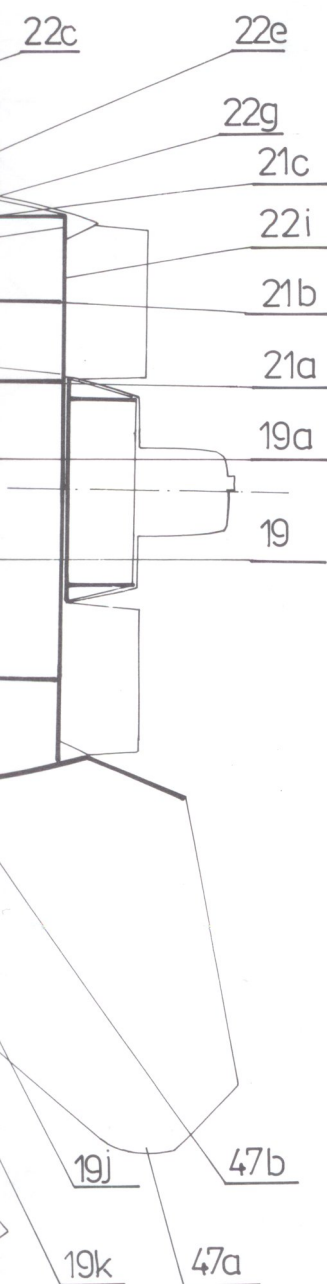
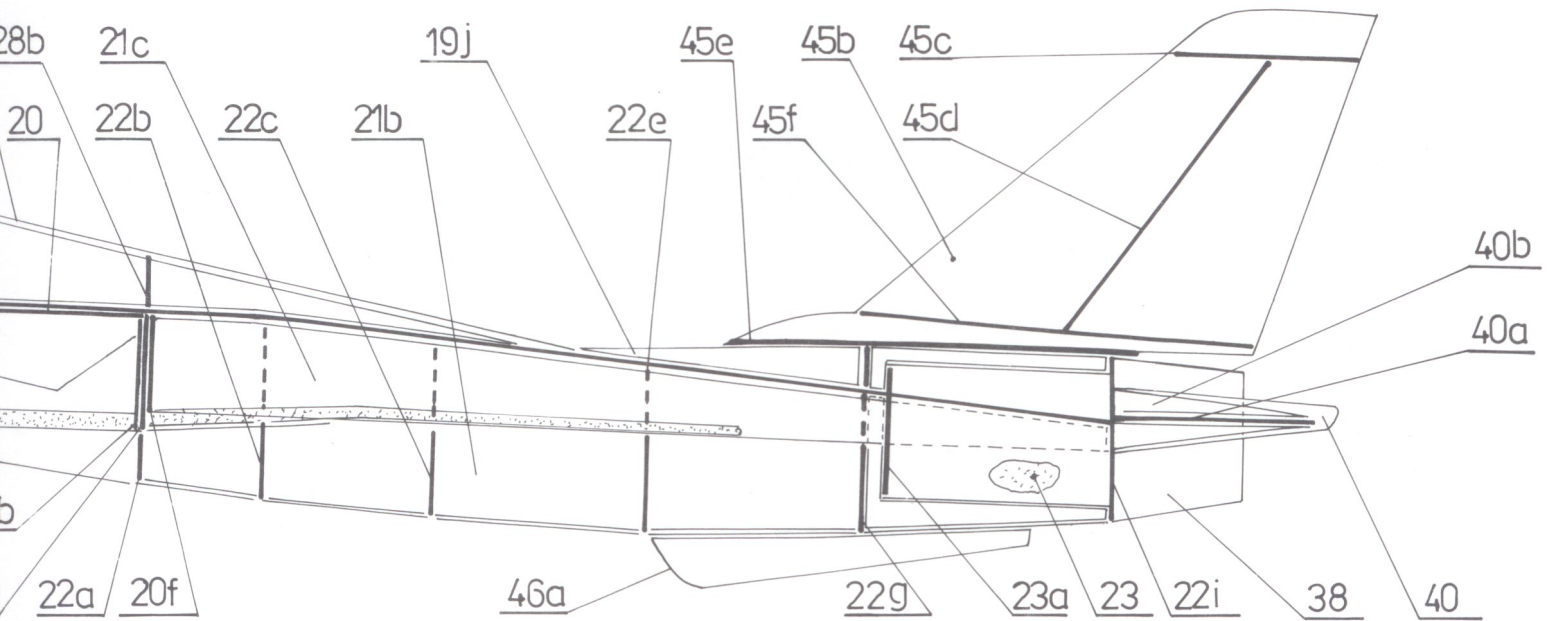

RYS.3 SZABLON DO WYKONANIA CZ 50c i 50d Z CELULOIDU

RYS.4

SZABLONY CZĘŚCI Z DRUTU  
SKALA 1:1

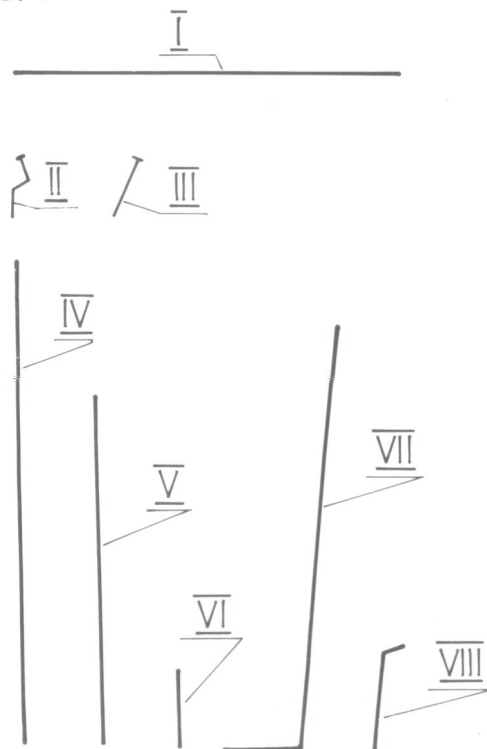

SZABLONY KÓŁ. SKALA 1:1

(po zrobieniu pomalować na czarno.

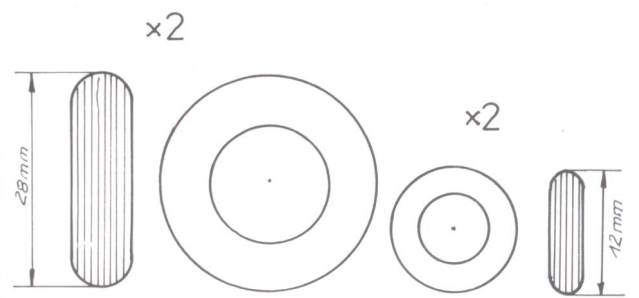

RYS. 6

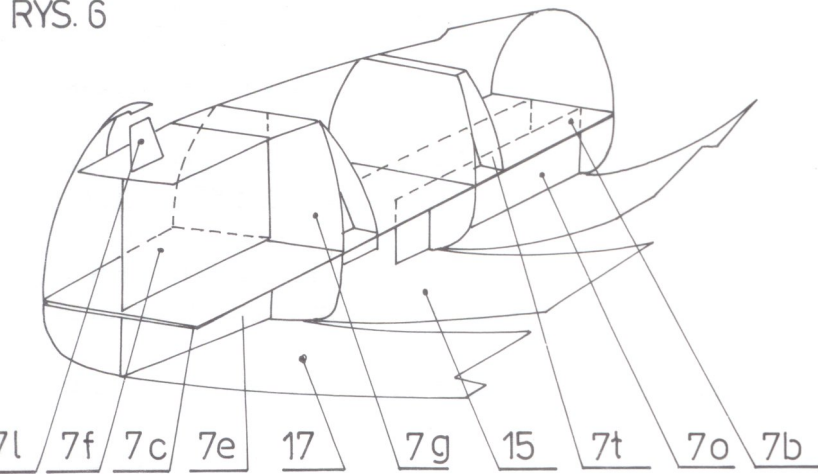

RYS. 7

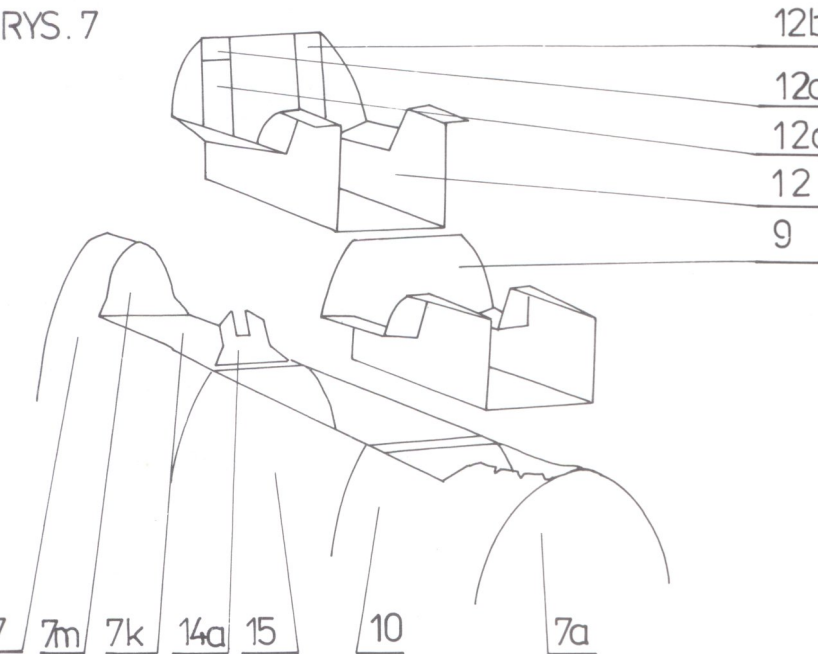

RYS. 8

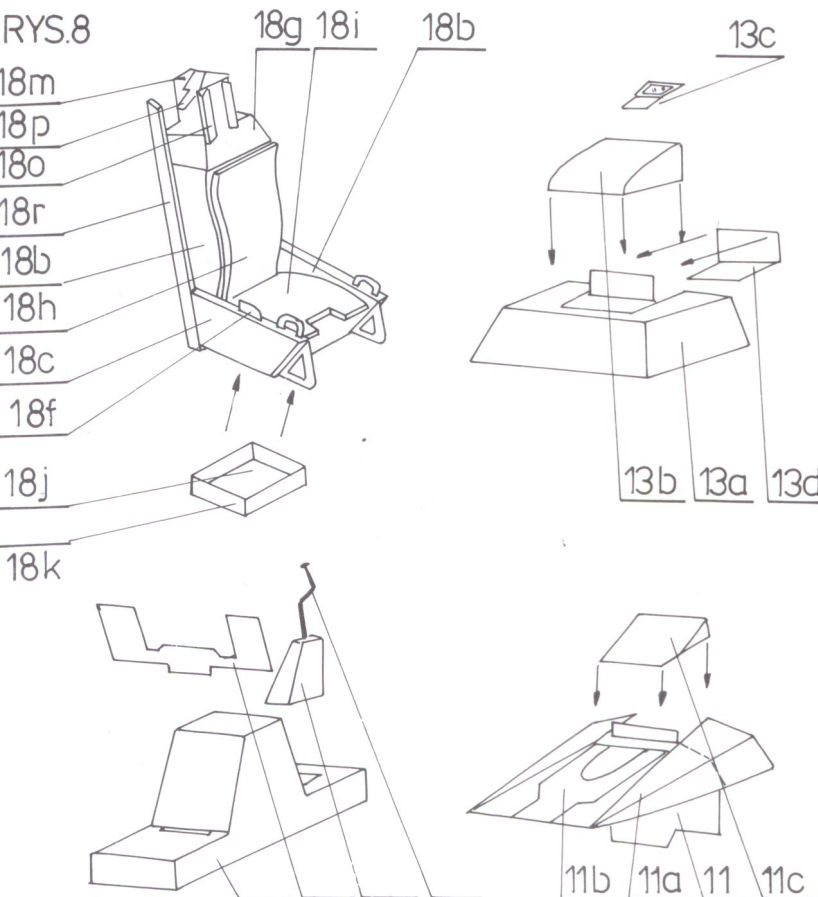

RYS. 9

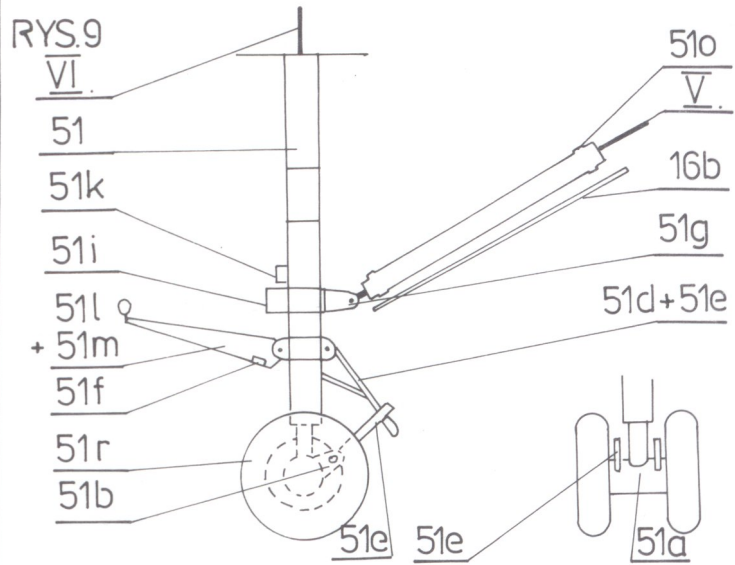

RYS. 10

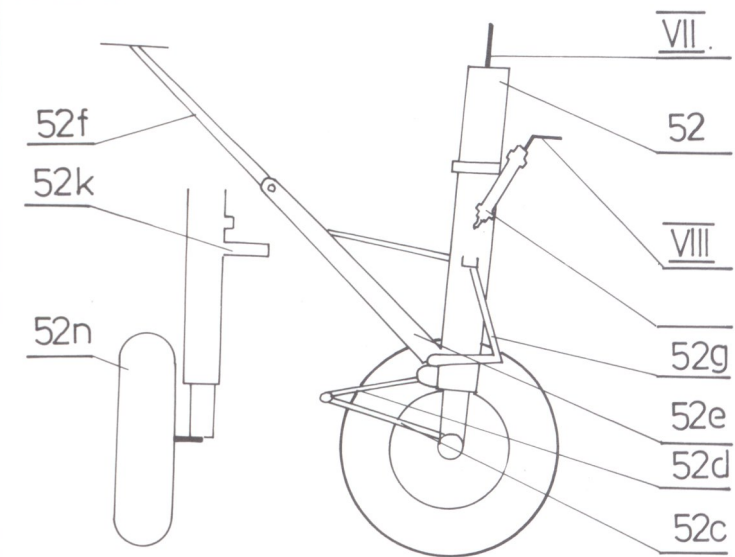

RYS. 11

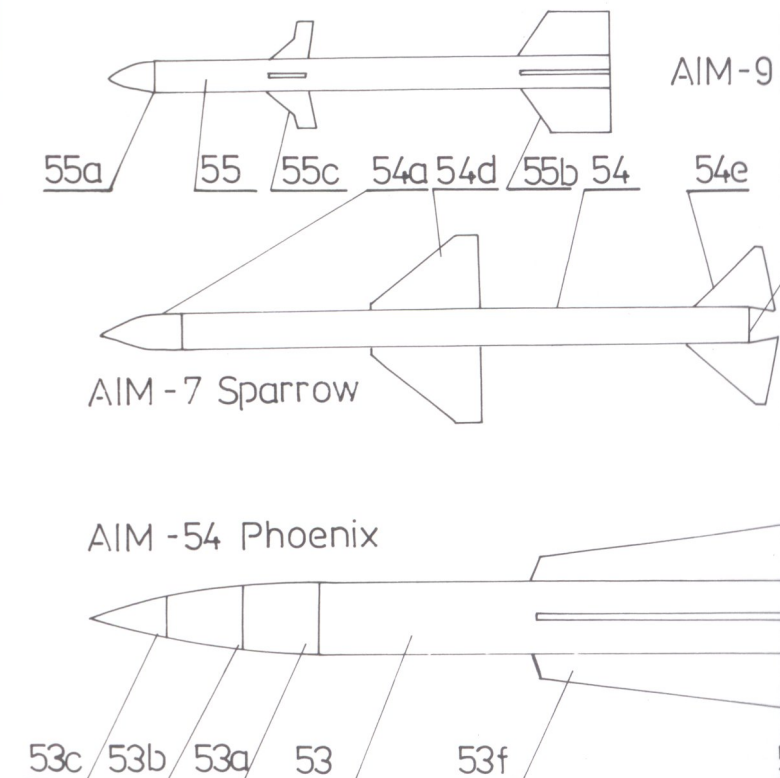

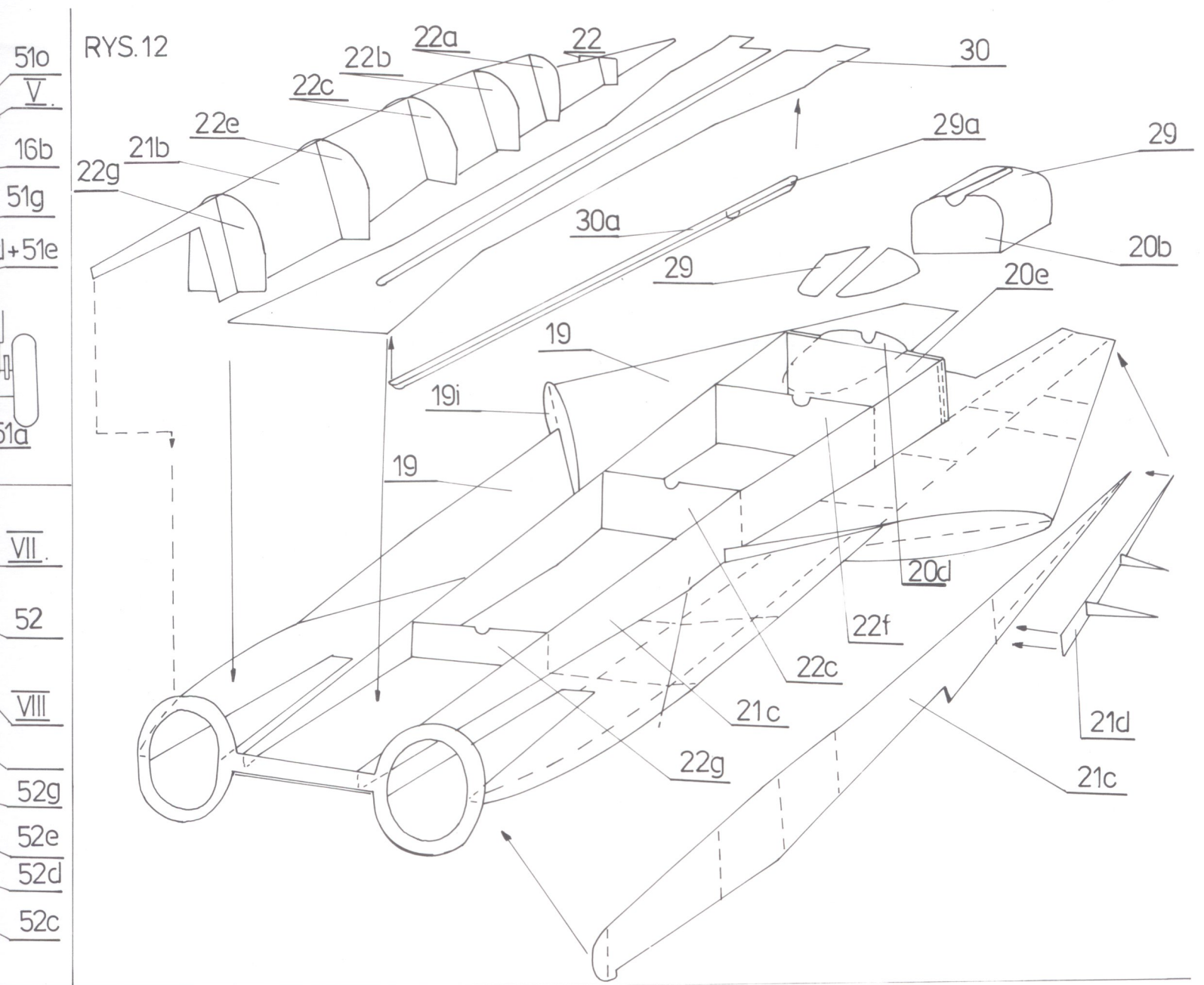

AIM-9 Sidewinder

