

AVRO VULCAN B. MK 2

opracowanie: Zbigniew Sajdak

Fly Model®

Nr 71

ISSN 1233-9423

WYDANIE I

MODEL
KARTONOWY
1:33



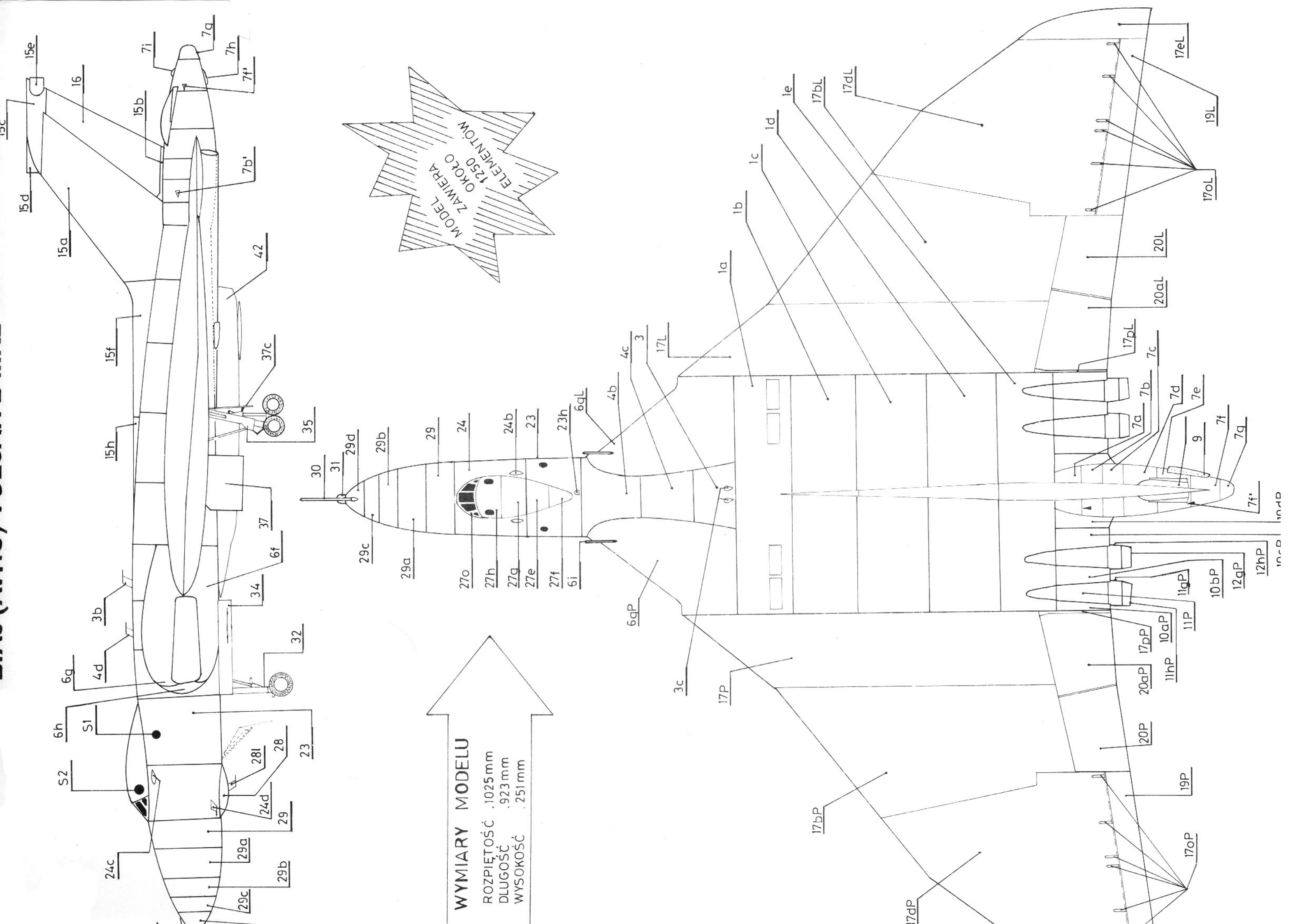

MODEL
 ZAWIERA
 OKOŁO
 1250
 ELEMENTÓW

WYMIARY MODELU

ROZPIĘTOŚĆ .1025mm
 DŁUGOŚĆ .923mm
 WYSOKOŚĆ .251mm

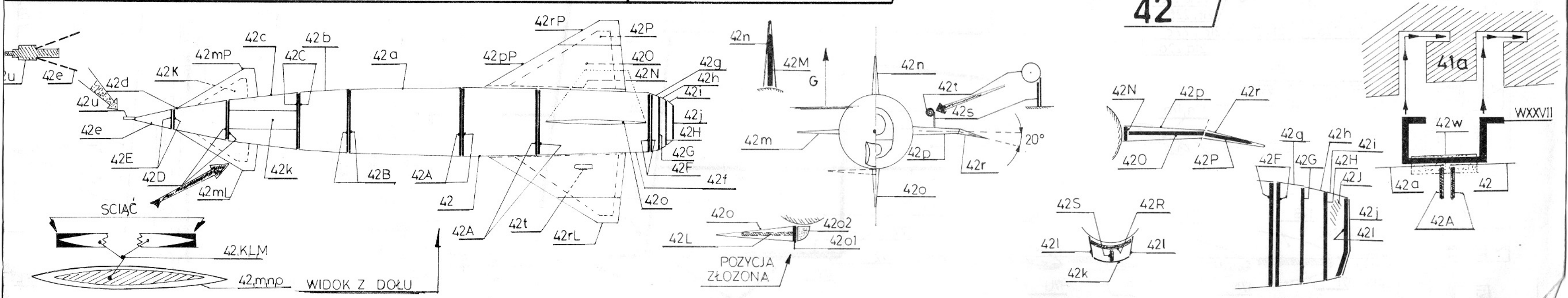
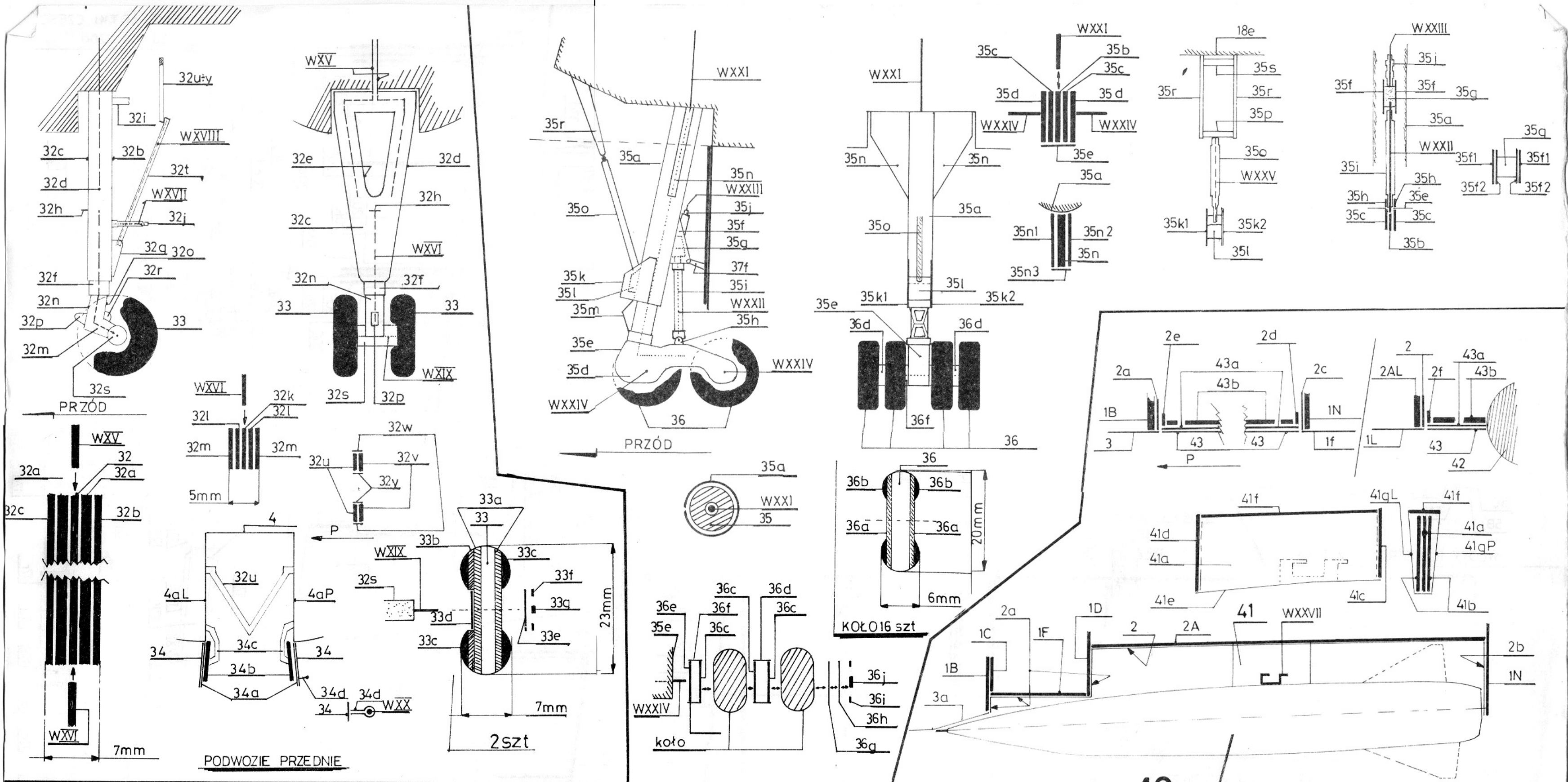

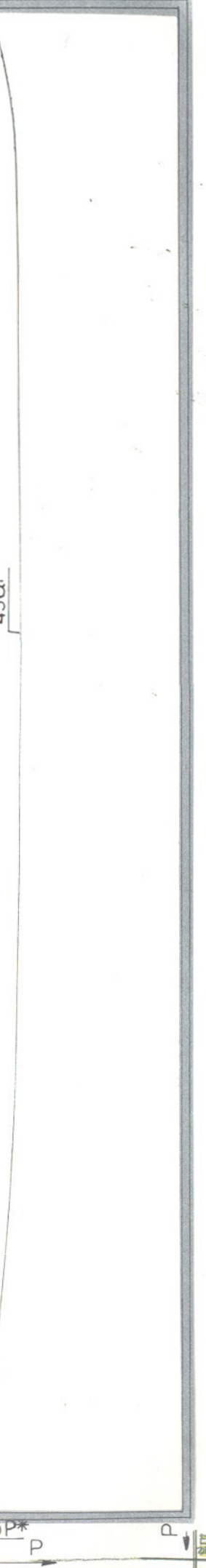
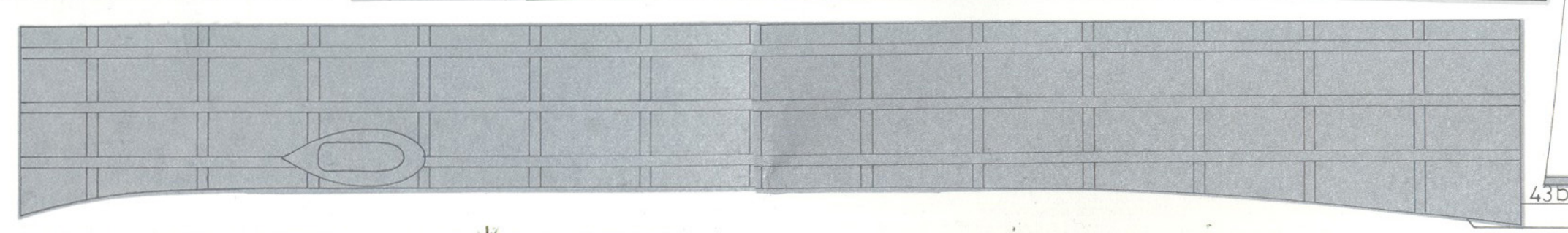
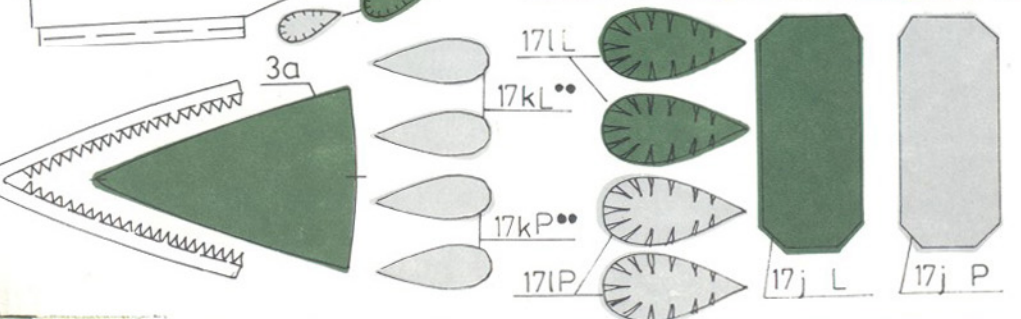
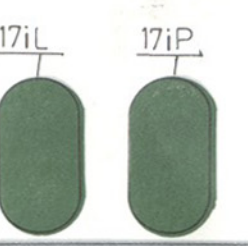
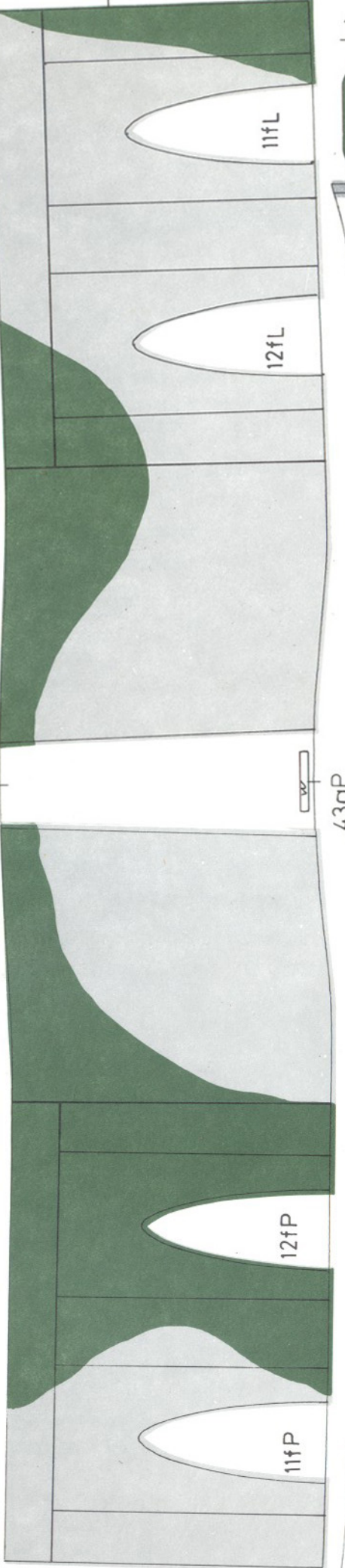
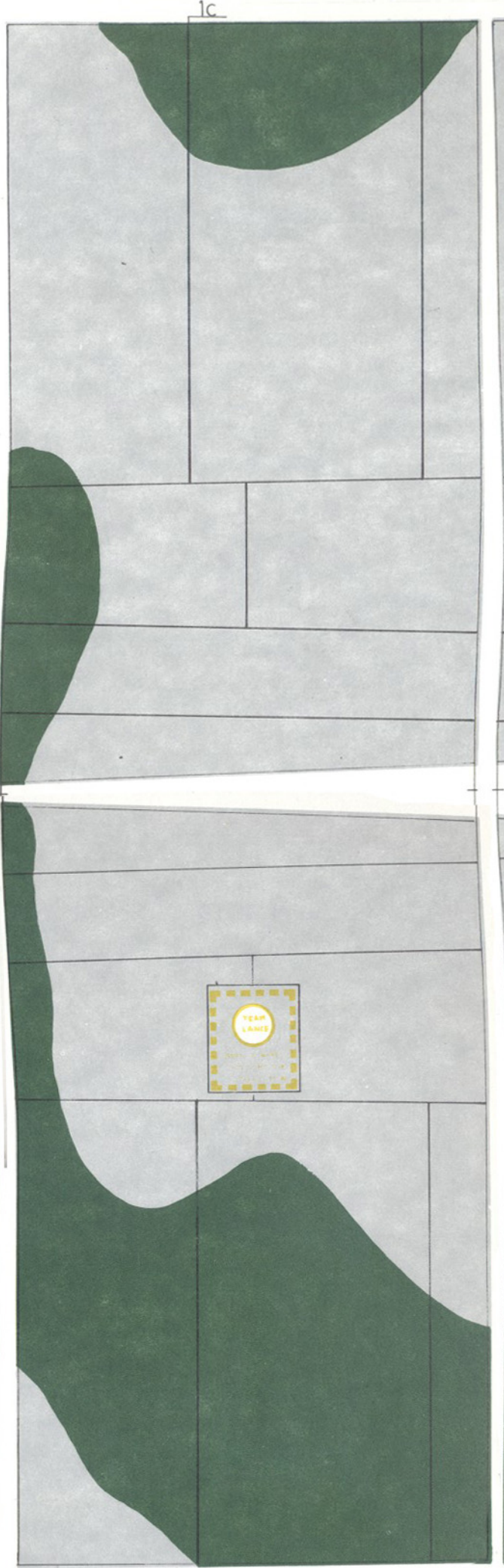
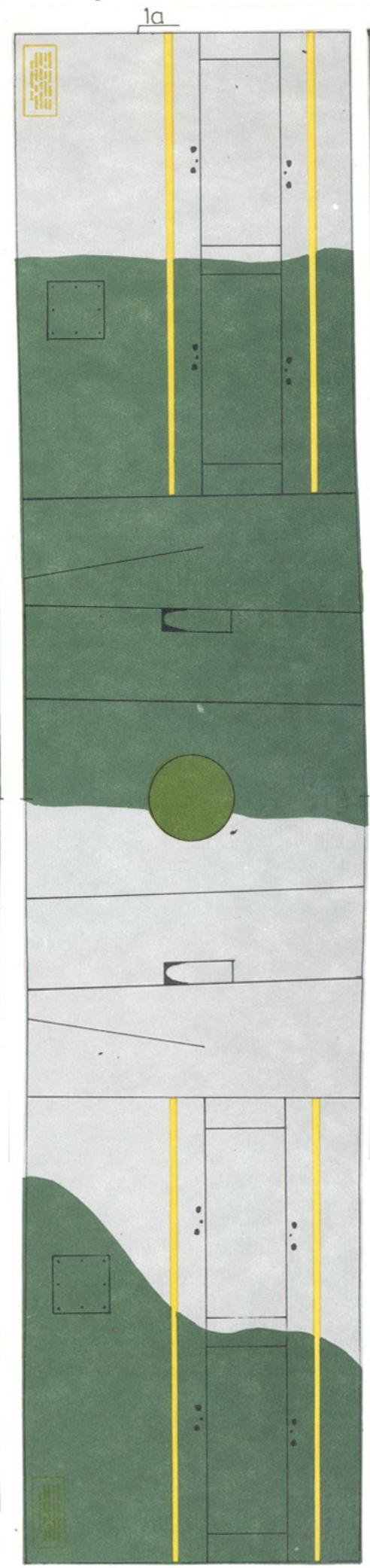
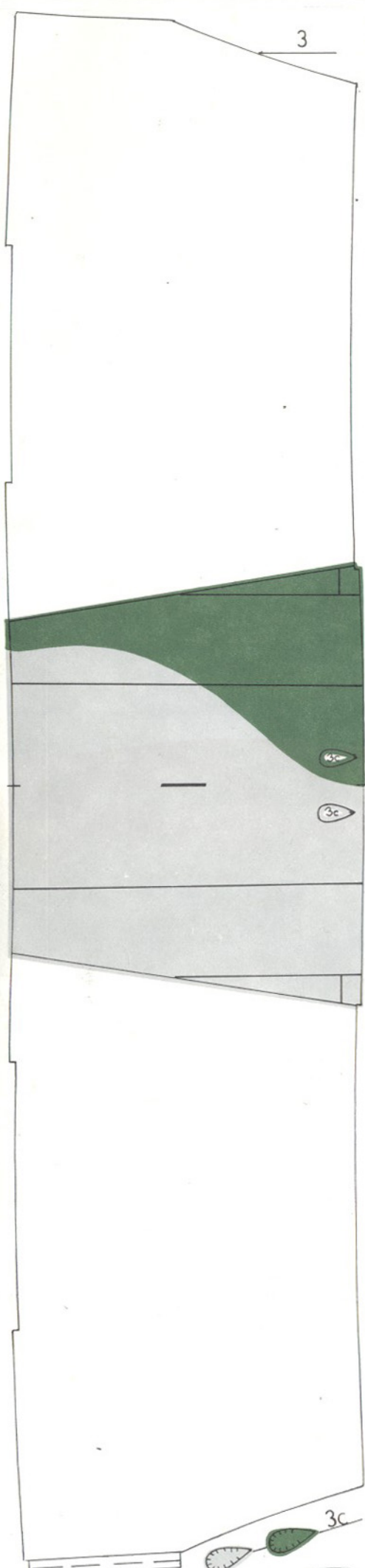



22bl

17L

17pP

17rP

17g

22fP

22fL

WYCIĄC

17pL

22cP

17rL

17cL

17hL

17hL

17qL

17qL

17eL

17aL

37eL*

22bP

22cl

37dL



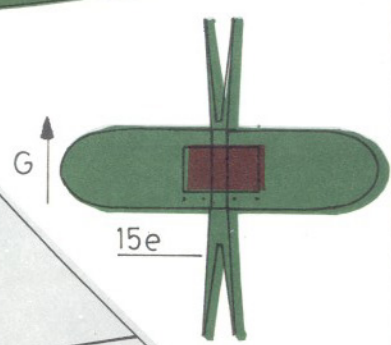
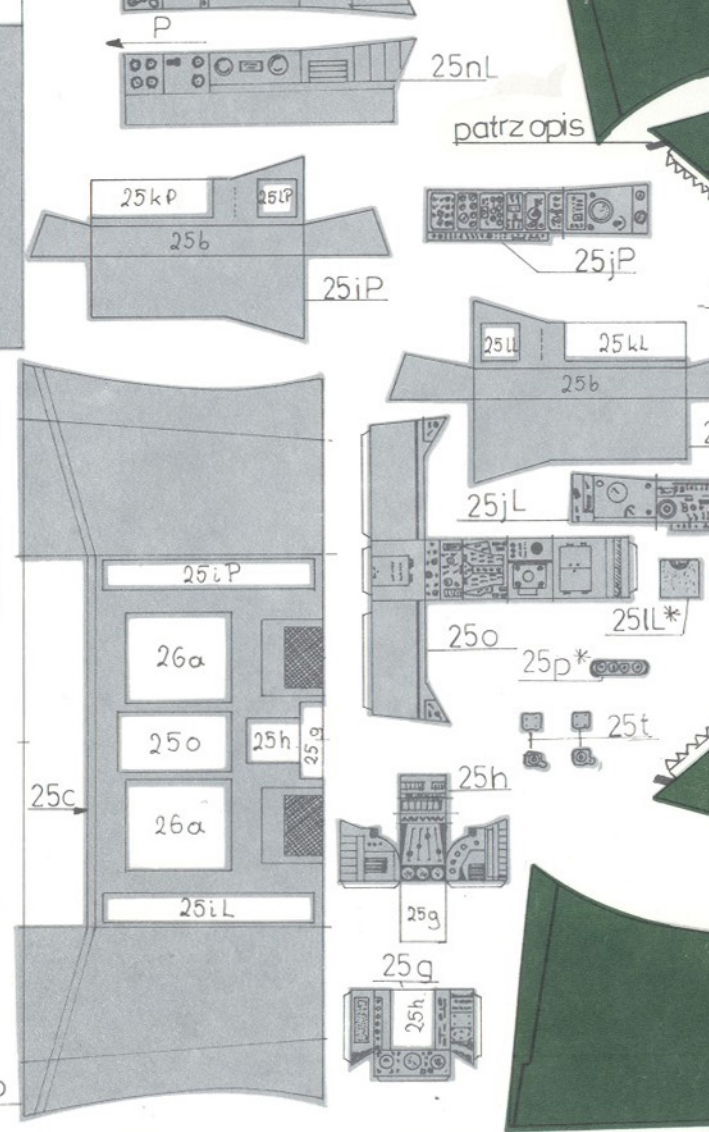
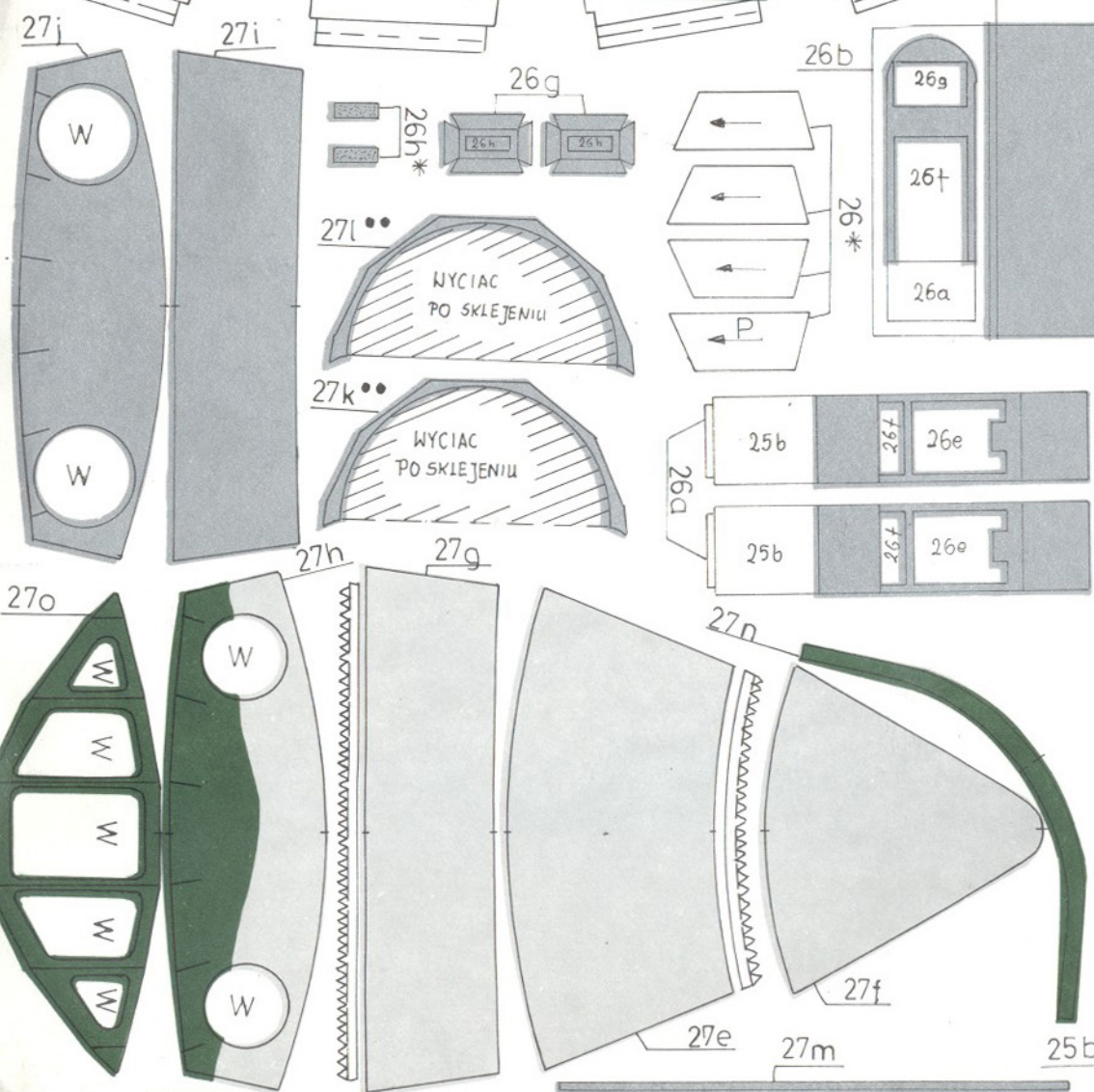
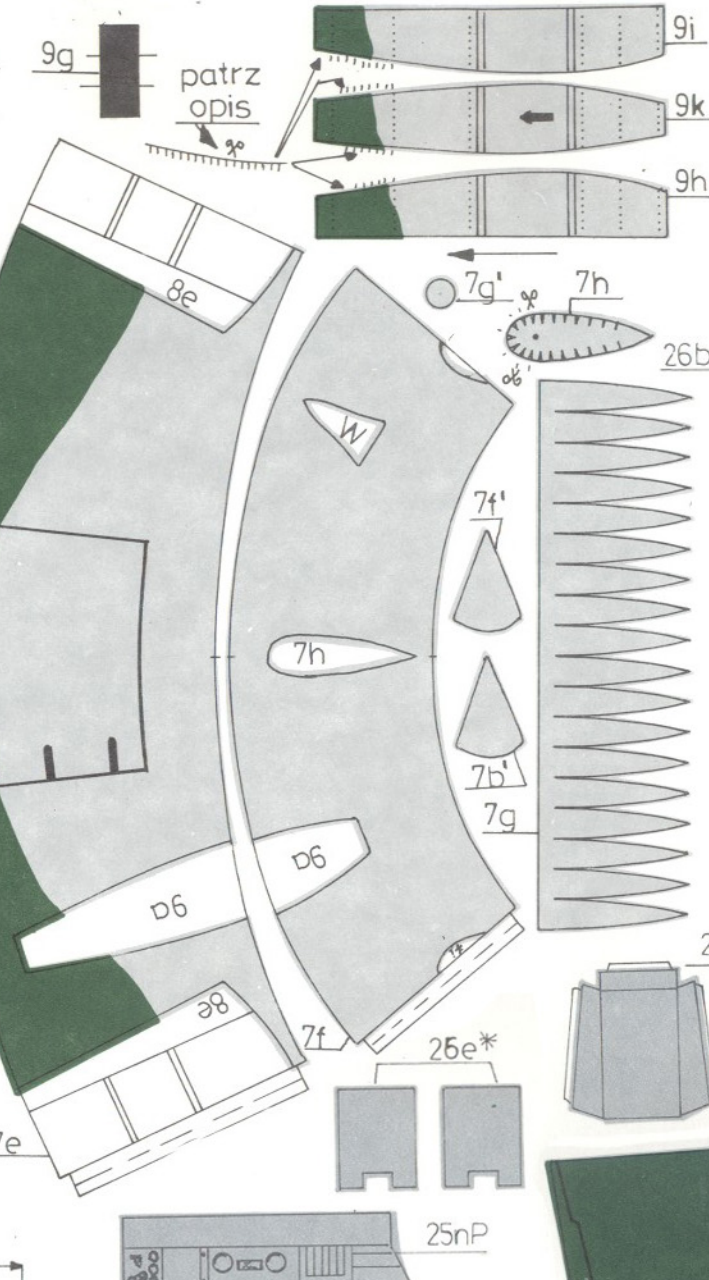
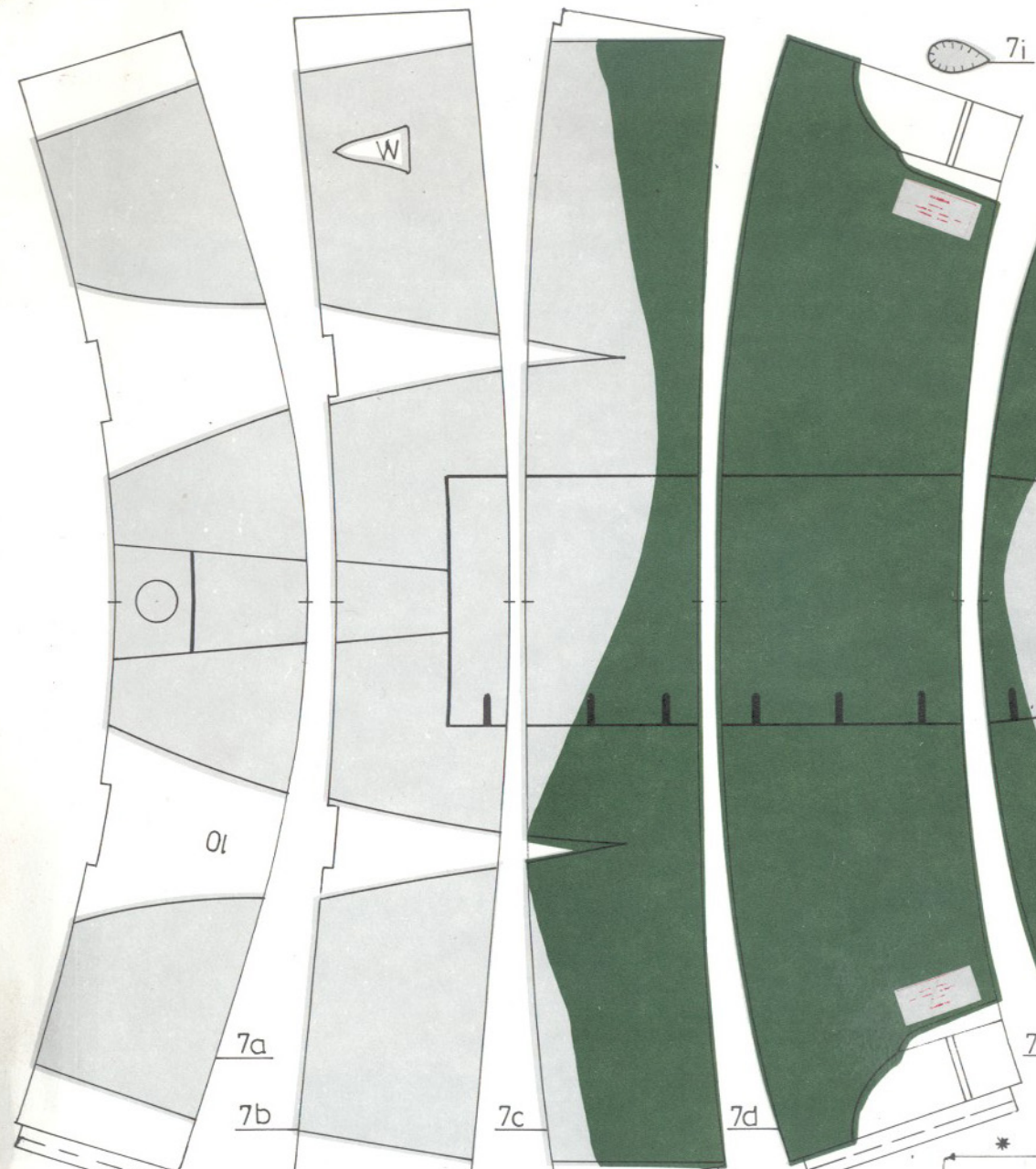
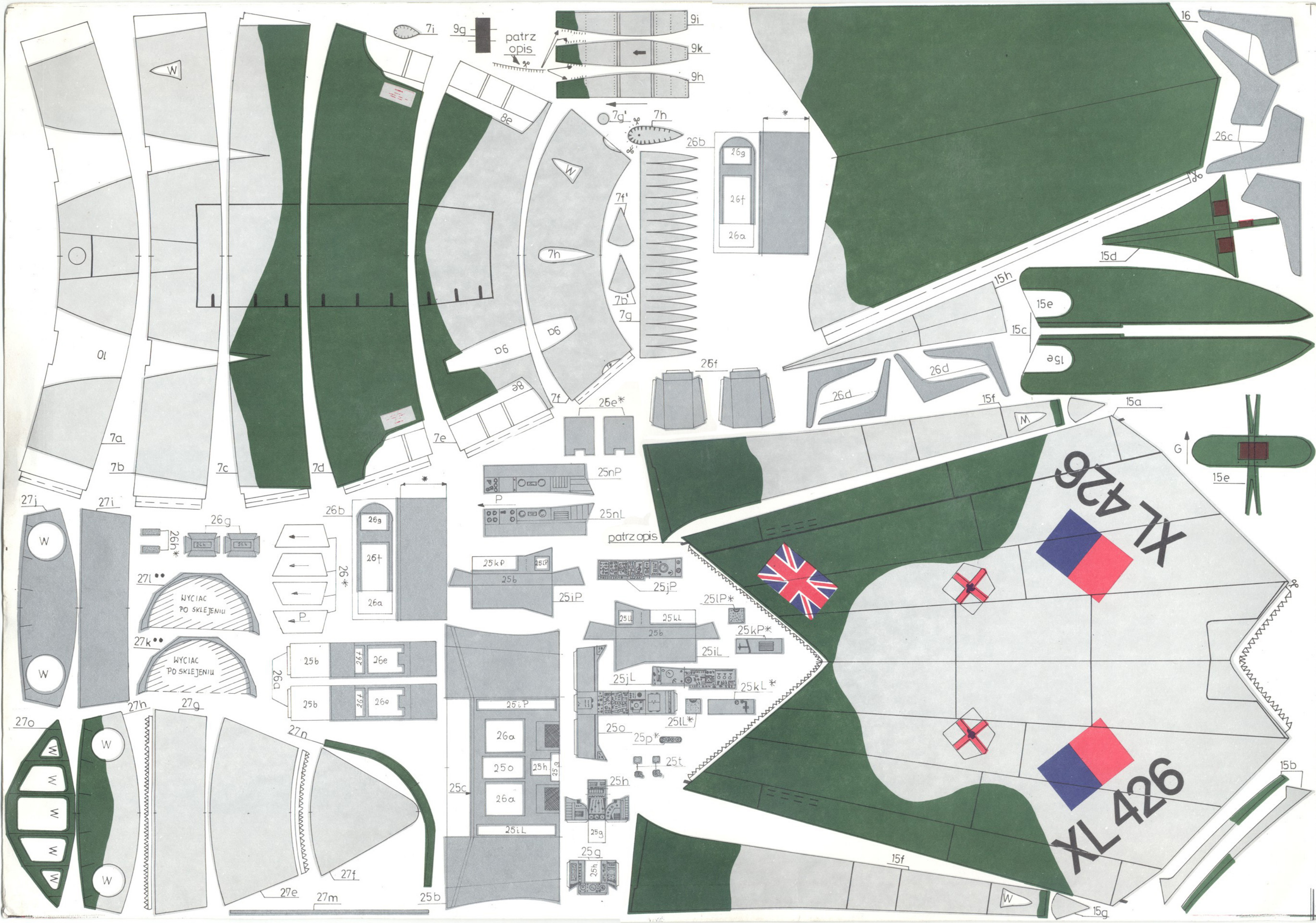

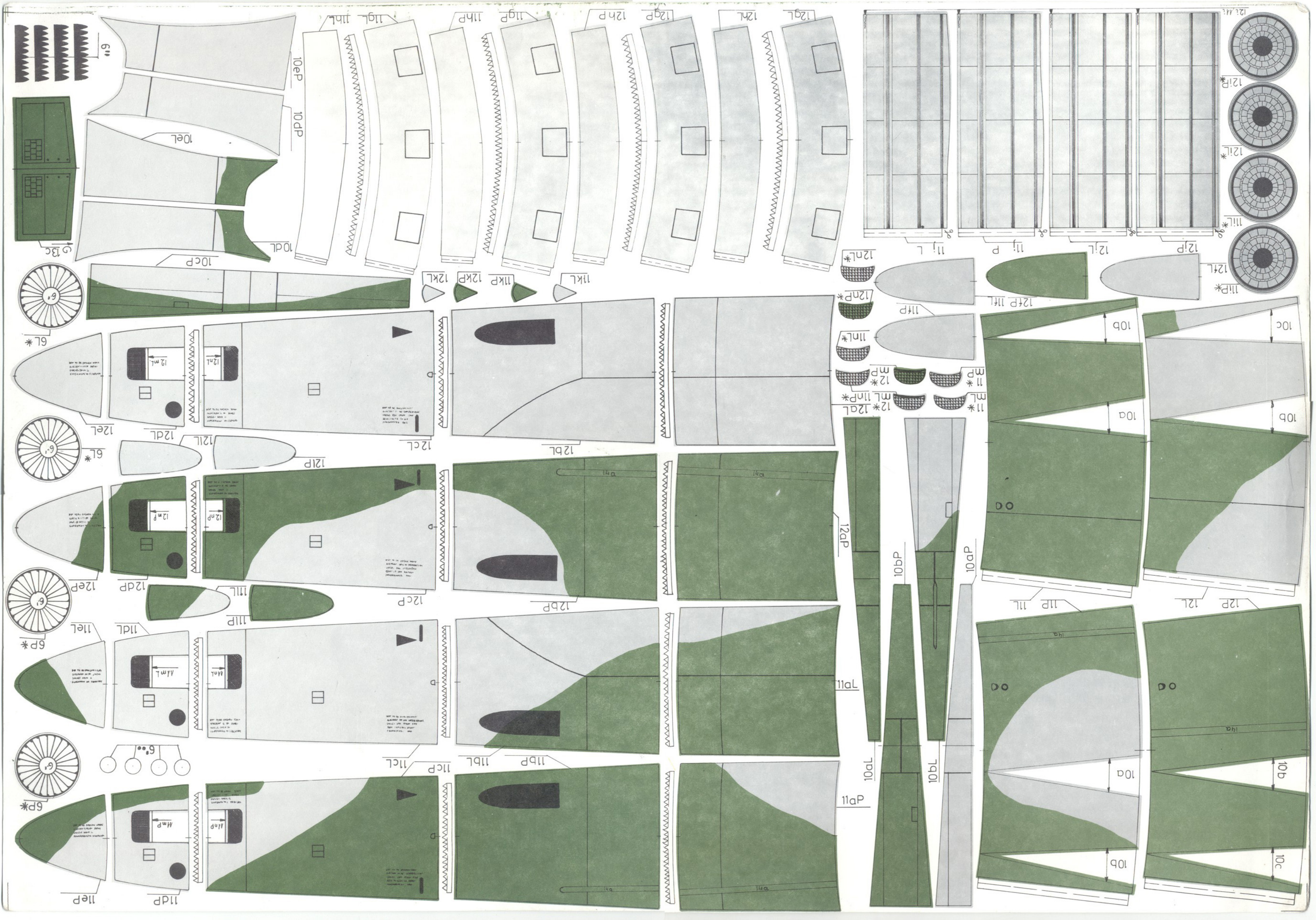

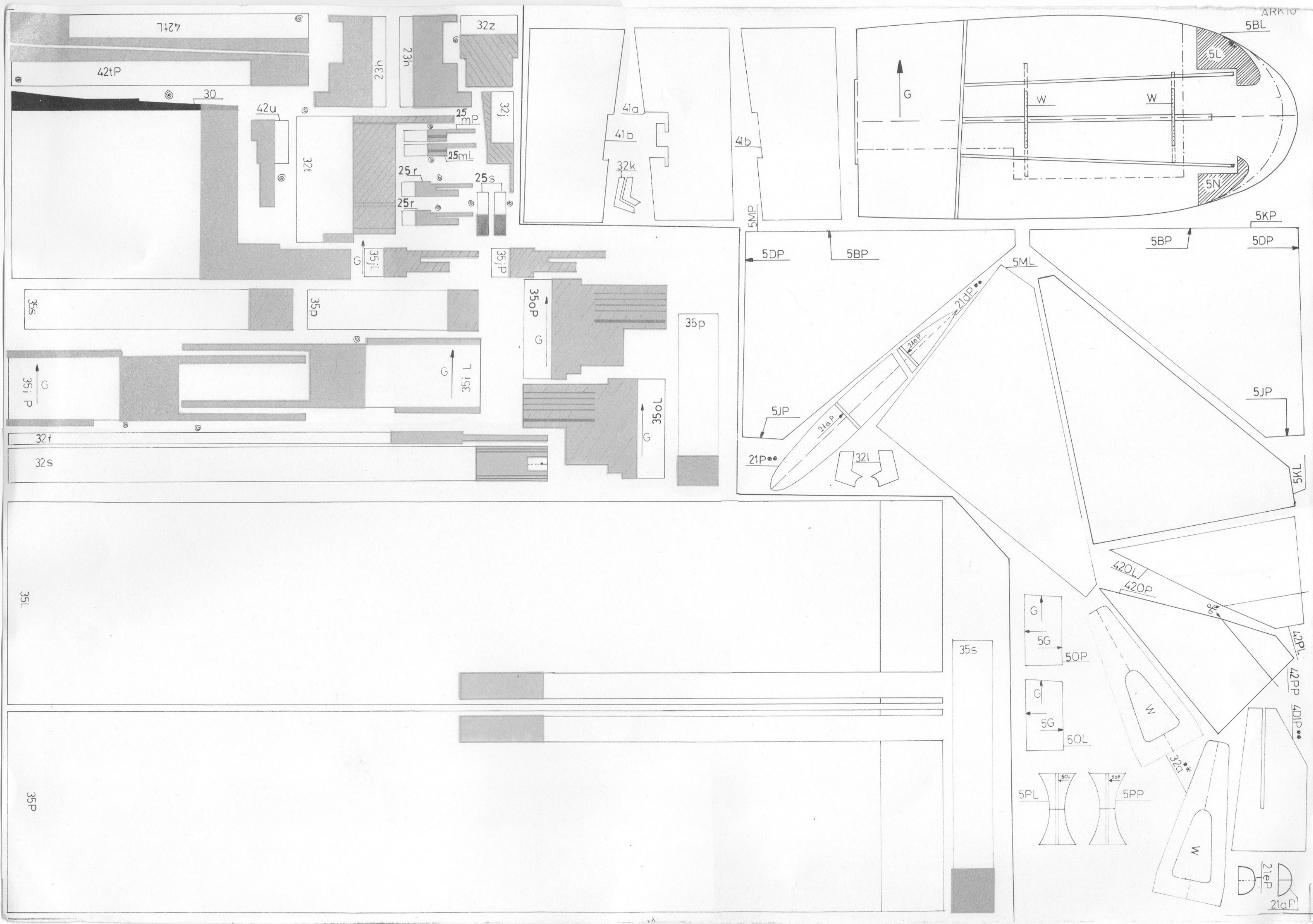

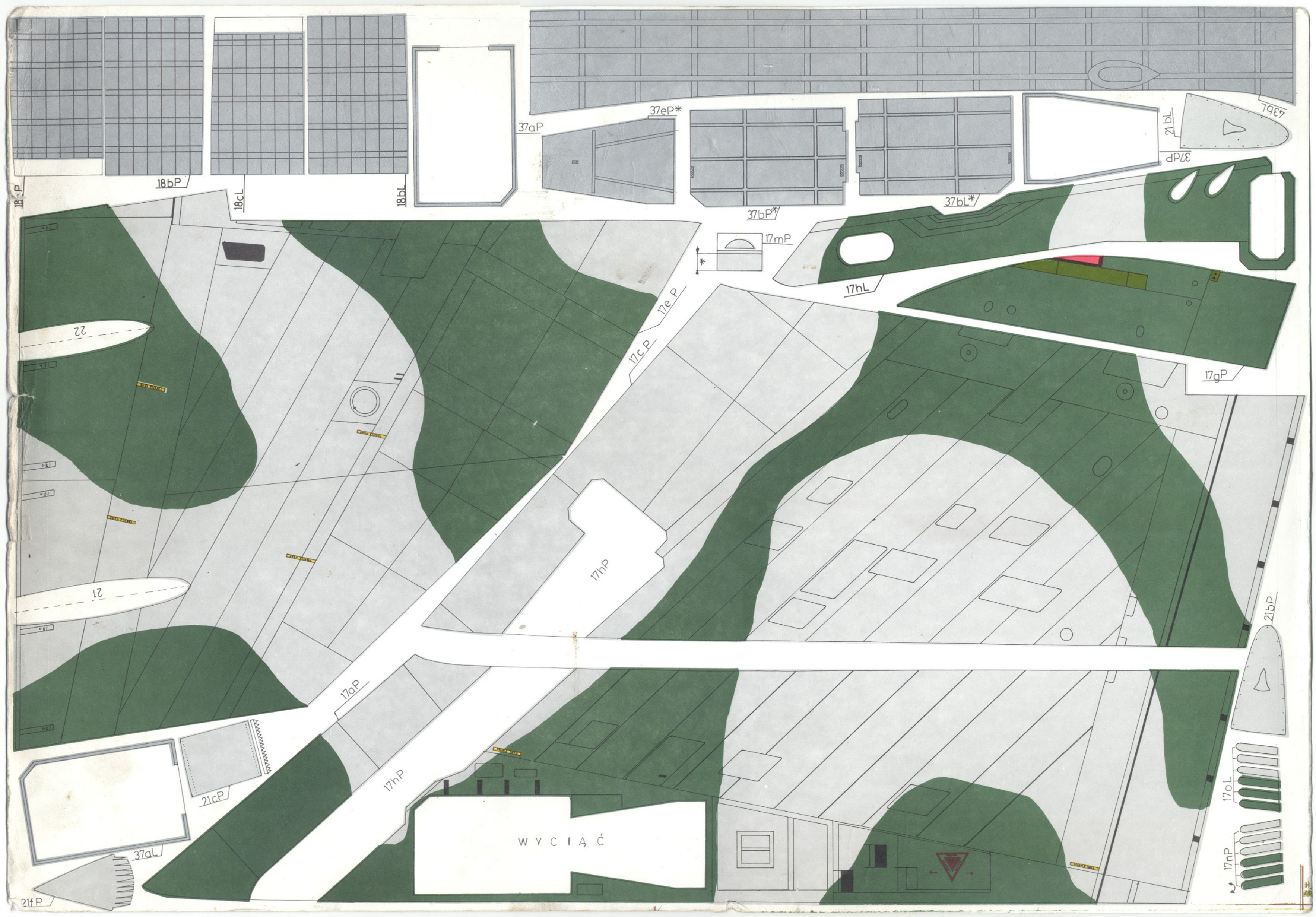

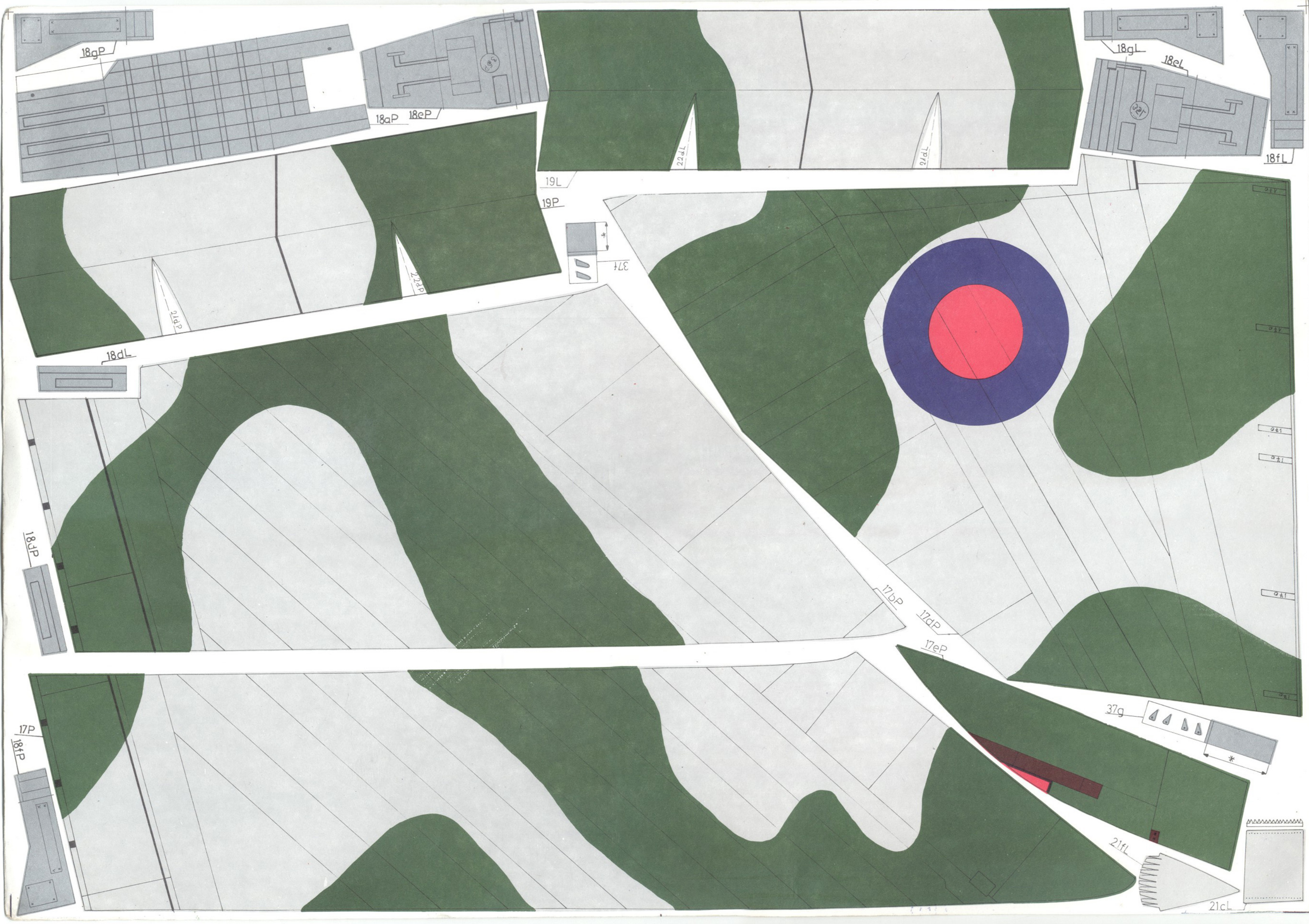

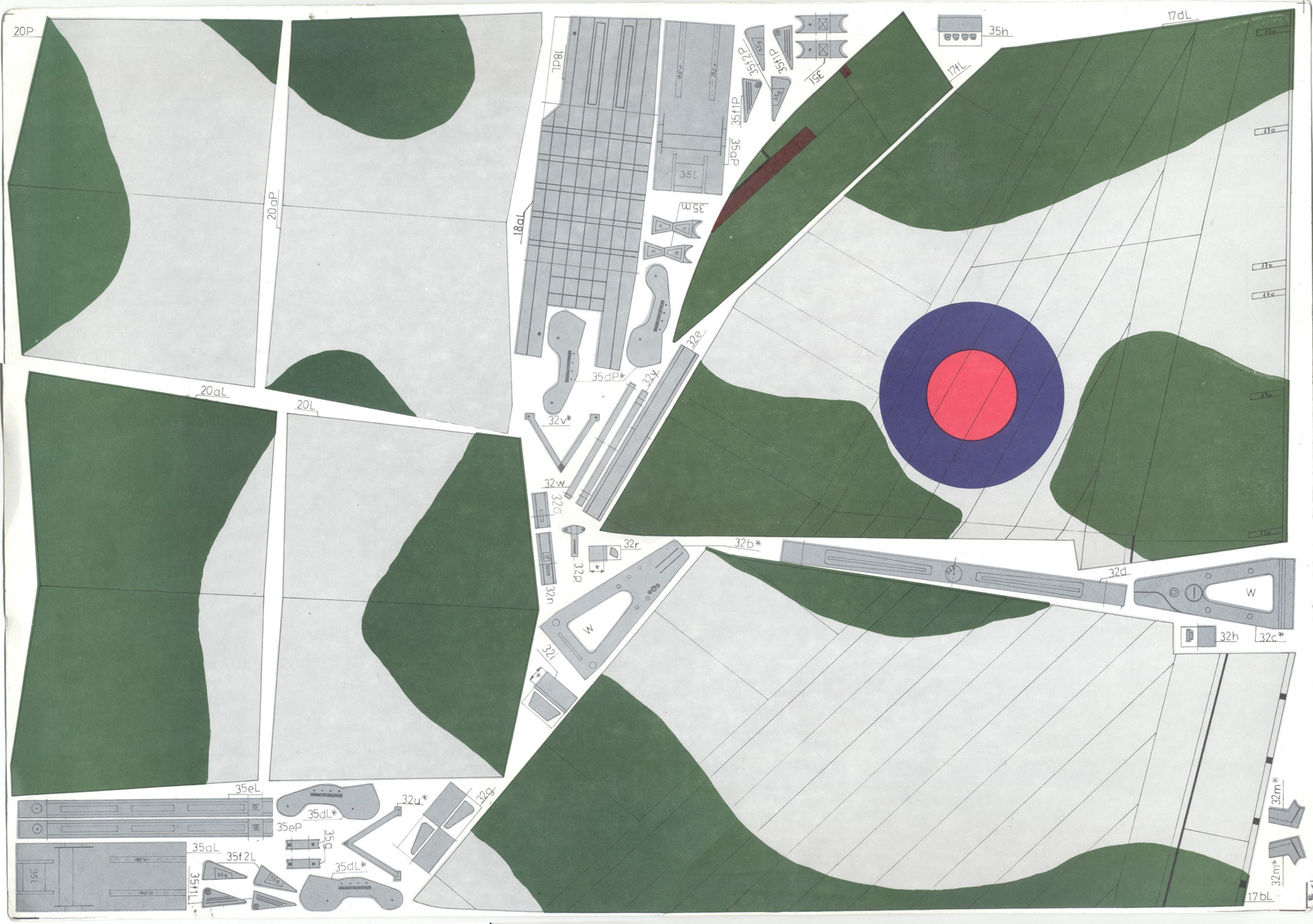

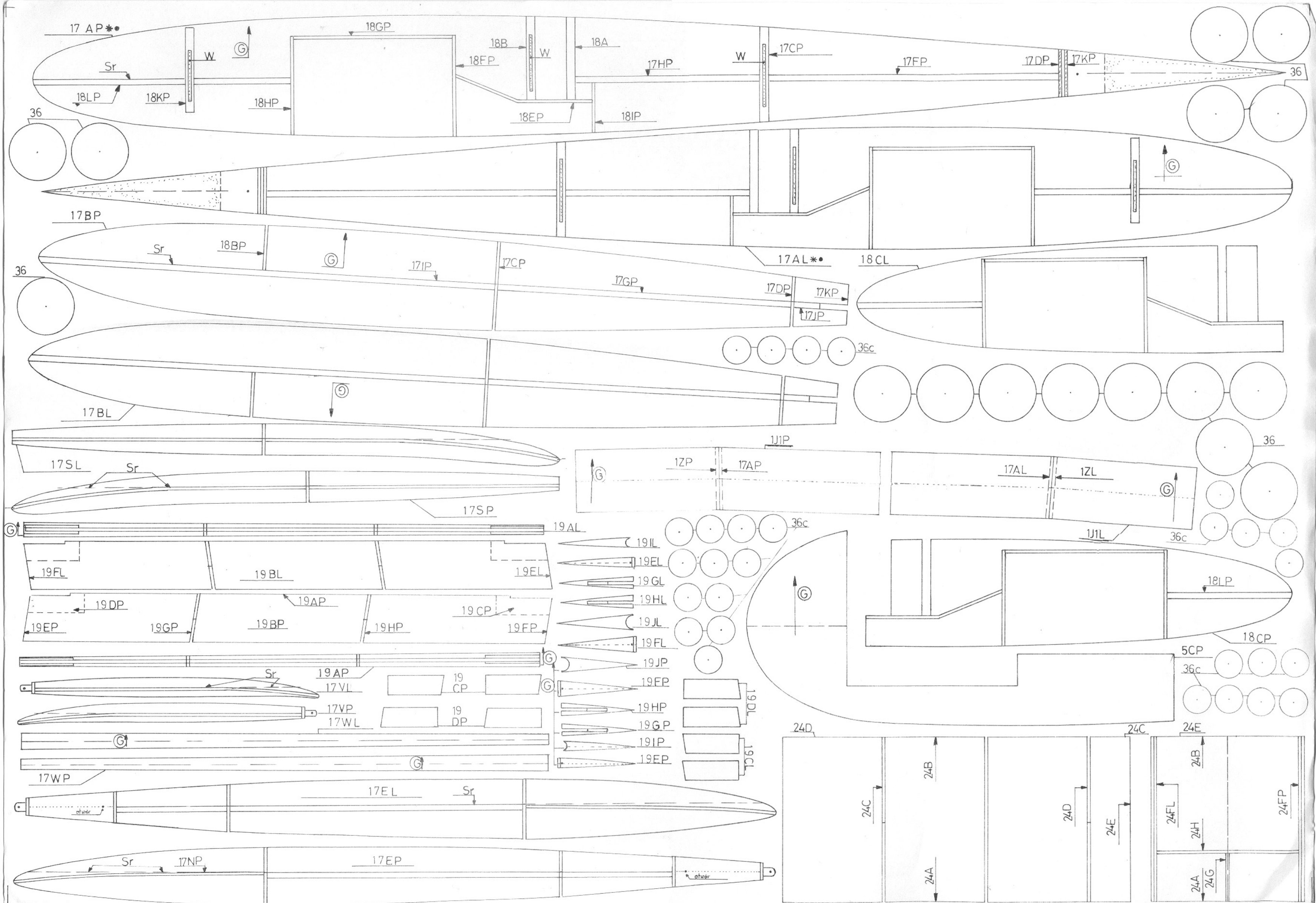

ARK7

