

HALIFAX

Fly Model 

Nr 57

ISSN 1233-9423
WYDANIE II

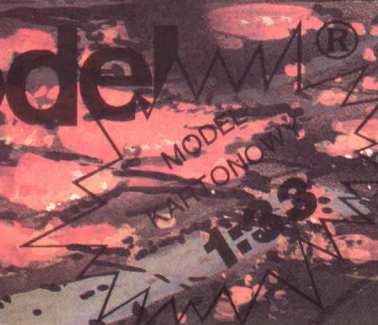

A. Cieslicki



PLAN OGÓLNY MODELU

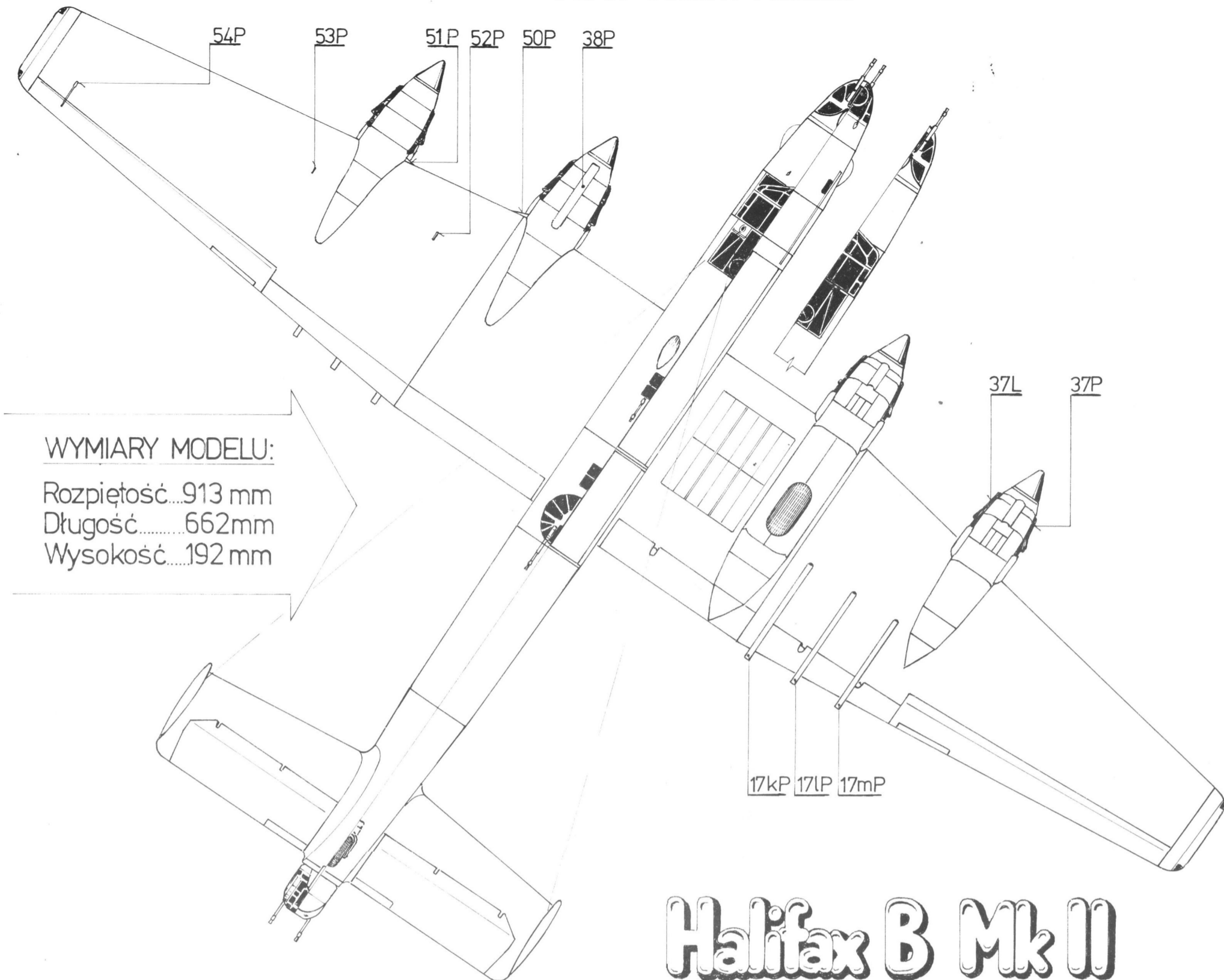

Halifax B Mk II

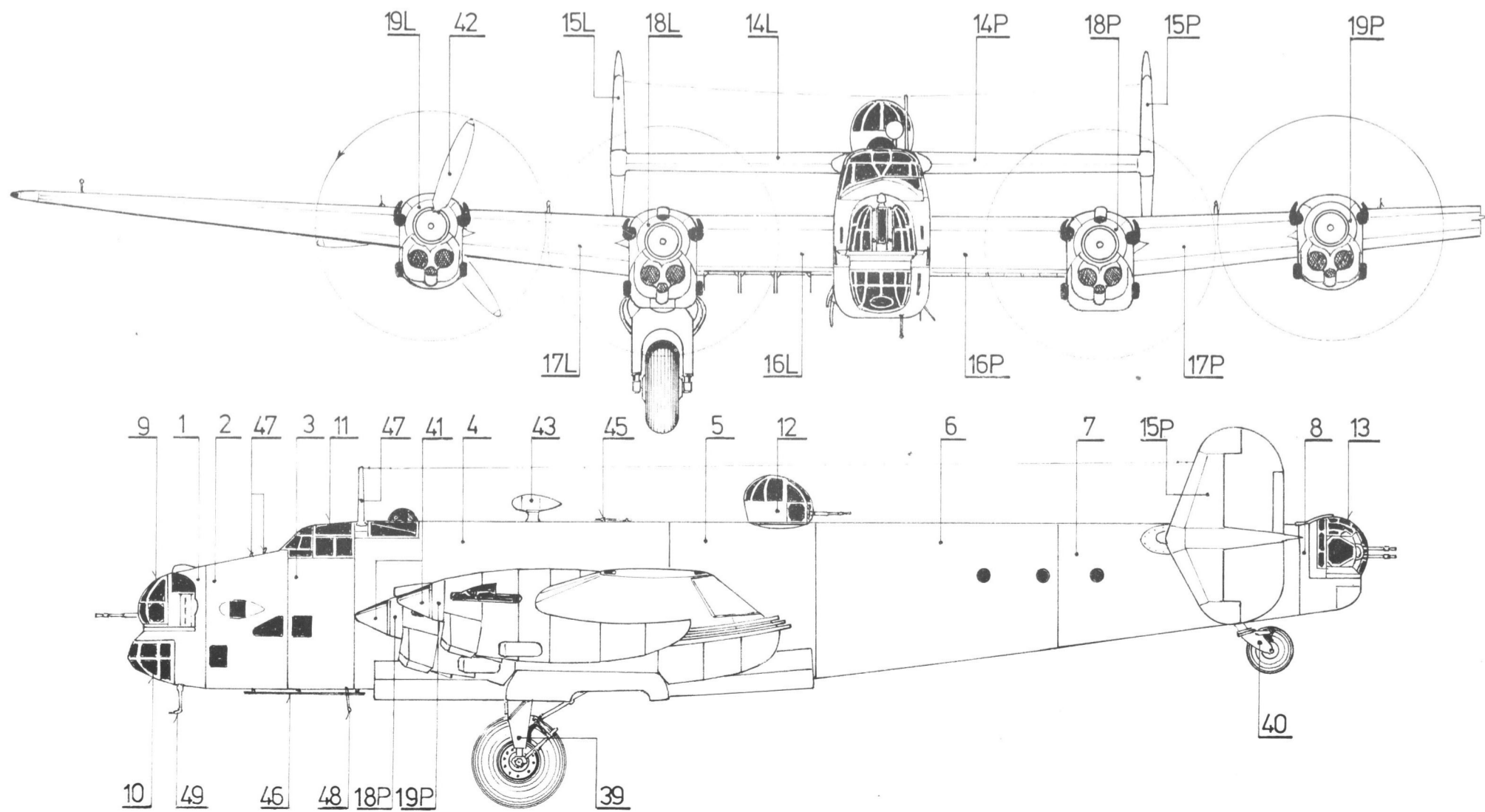

Ark. A

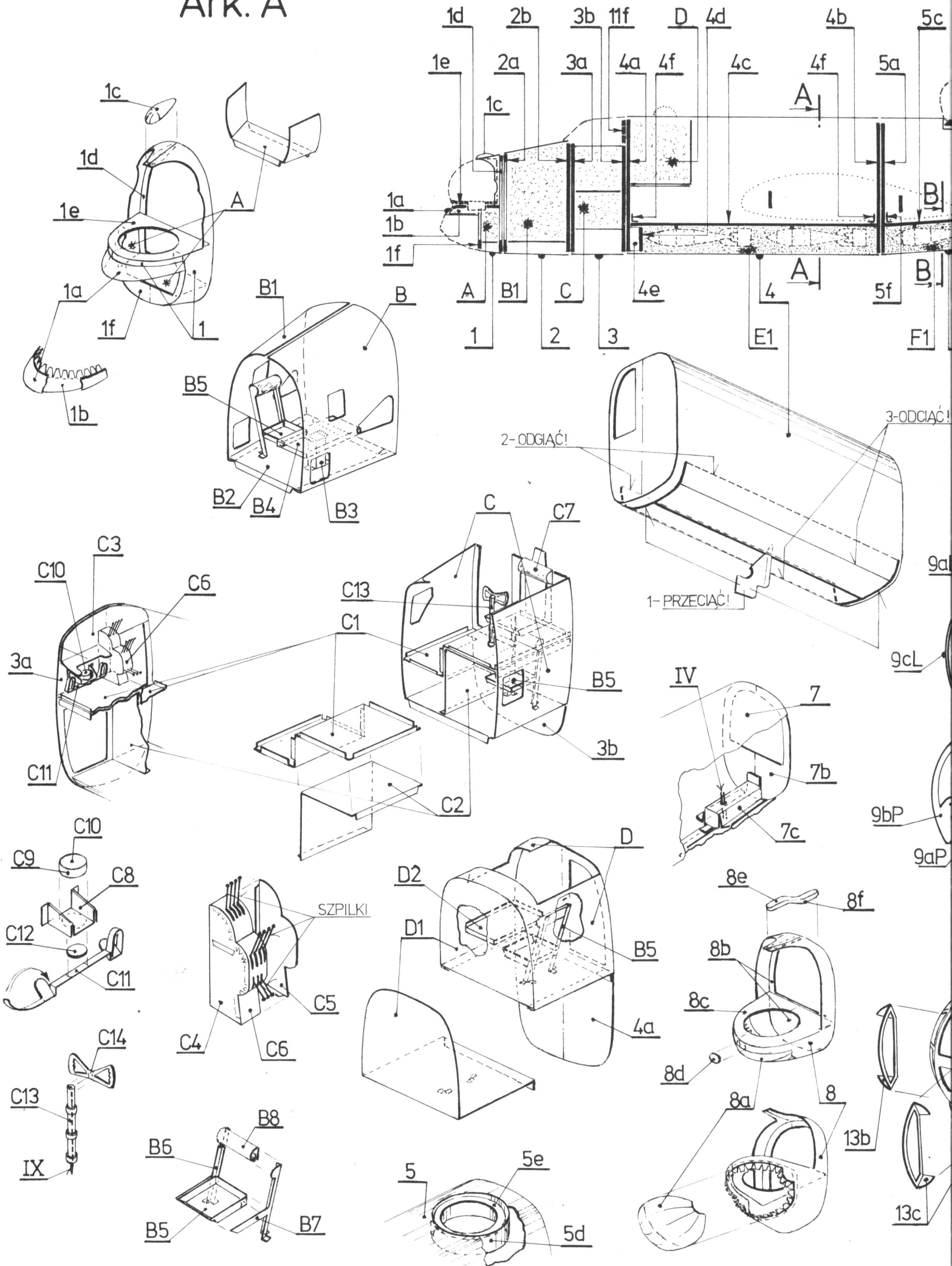

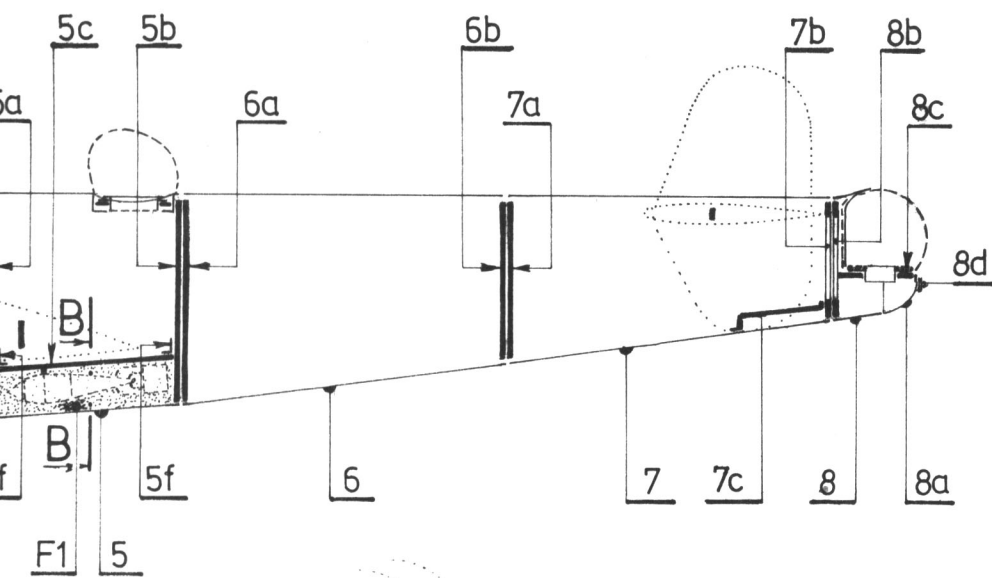

A-A
1:1

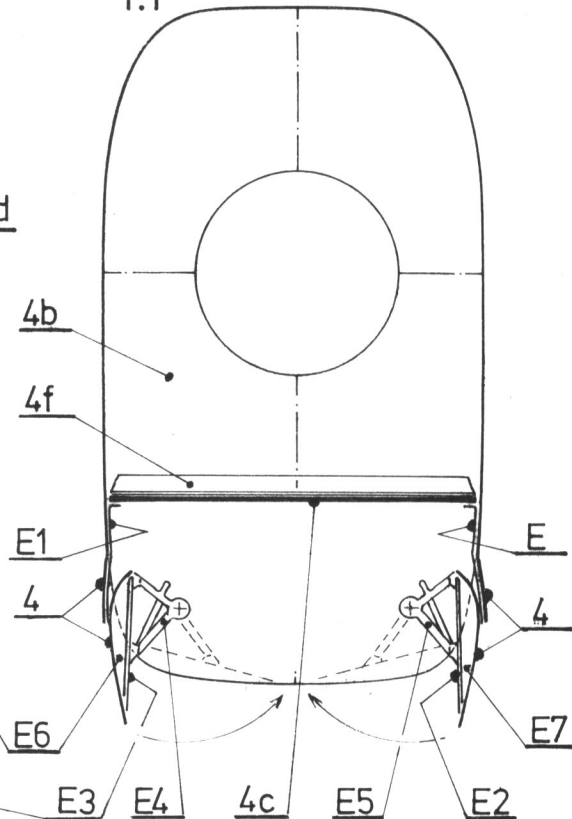

3-ODCIAĆ!

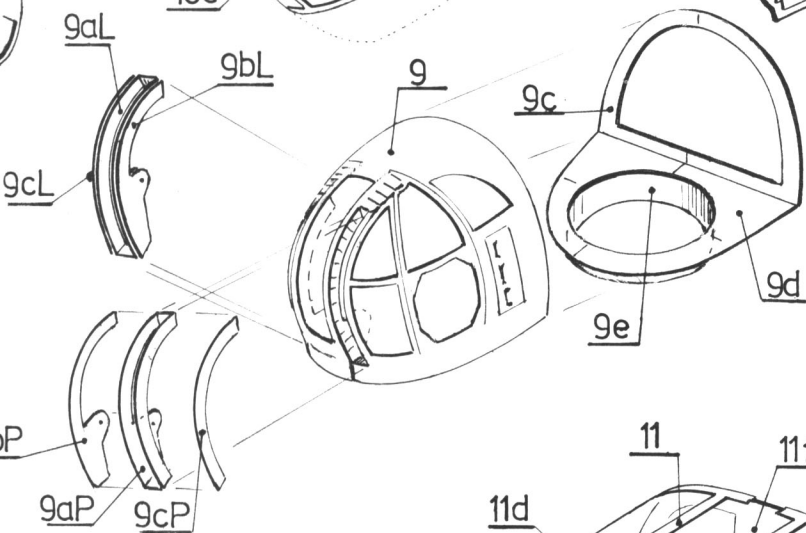
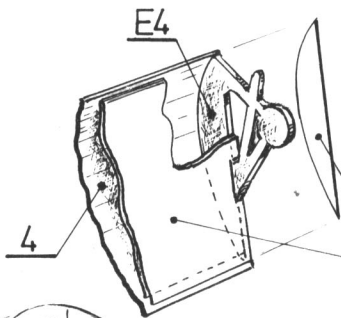
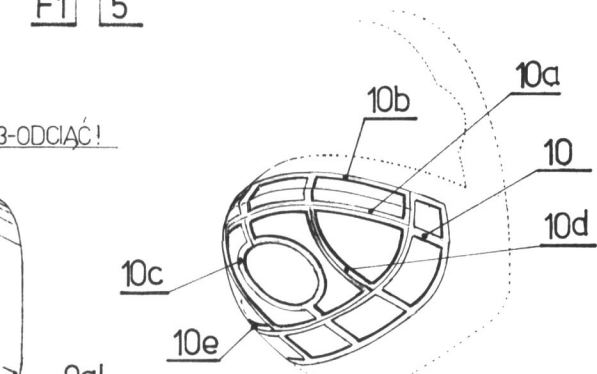

B-B
1:1

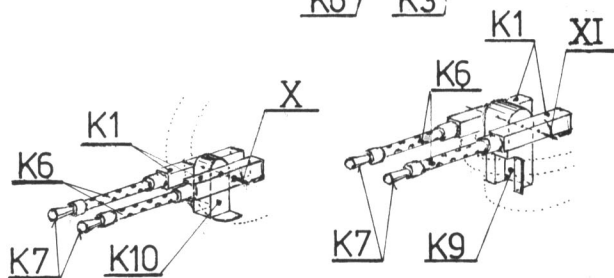
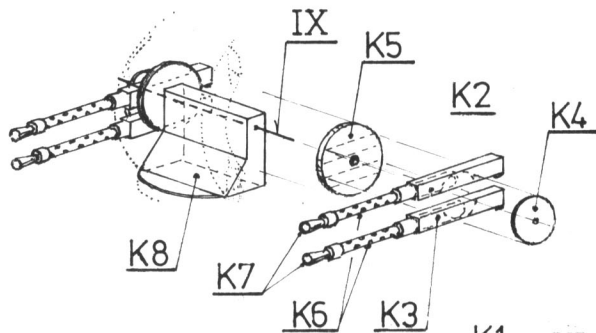
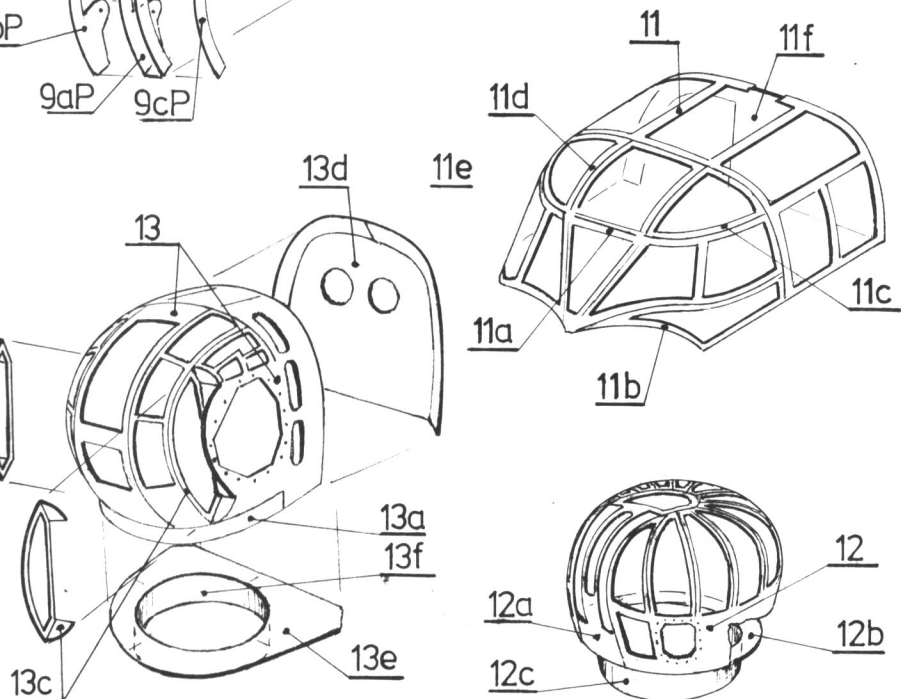
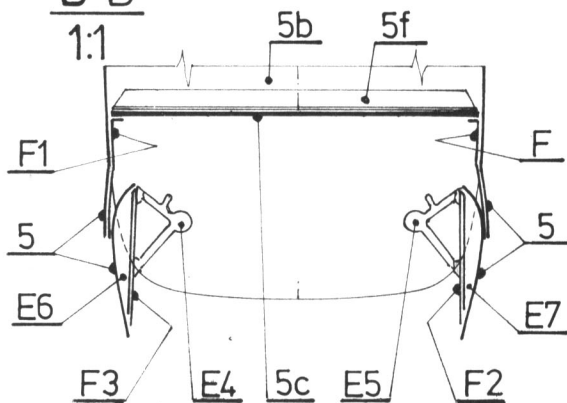

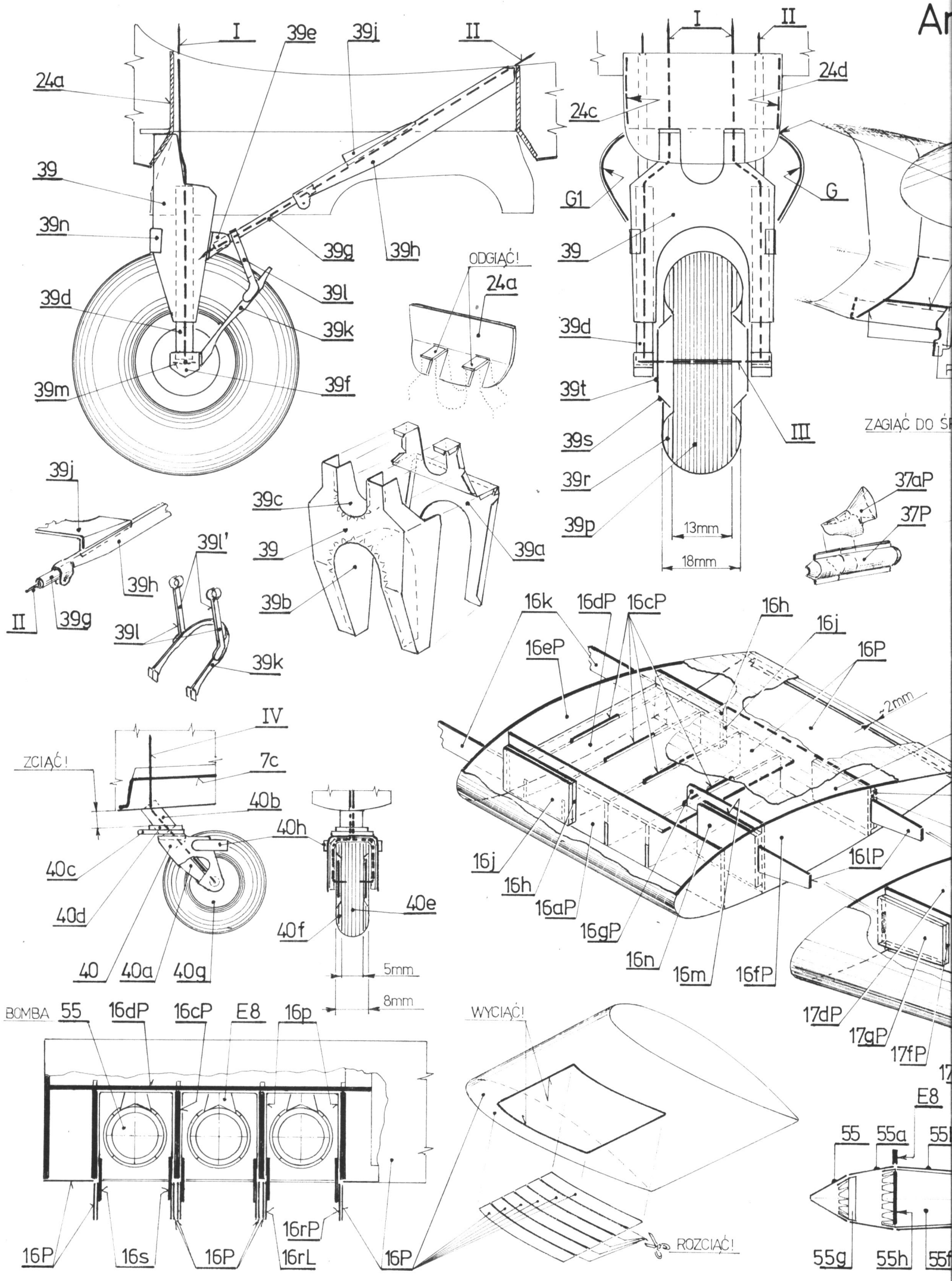

Ark.B

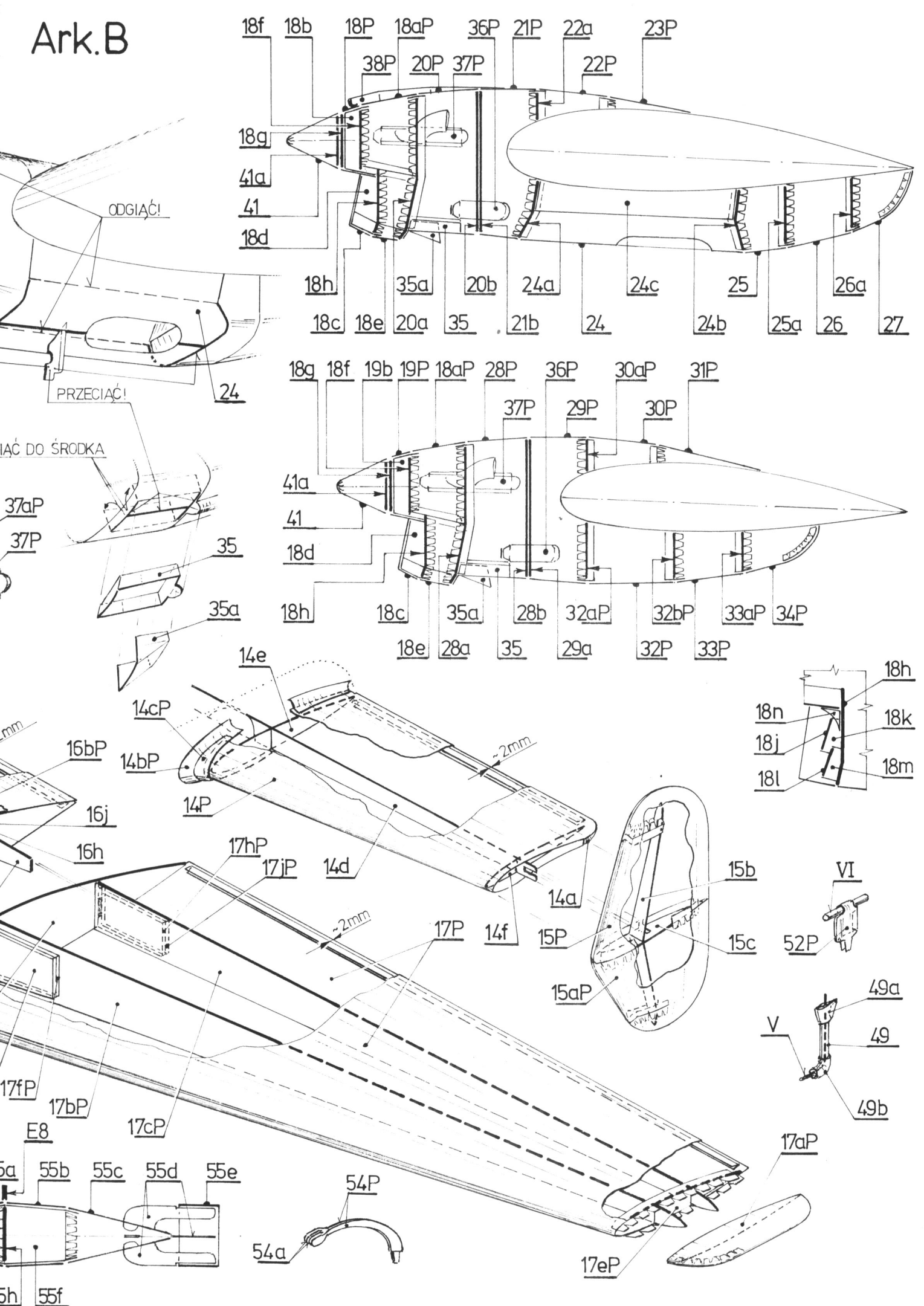

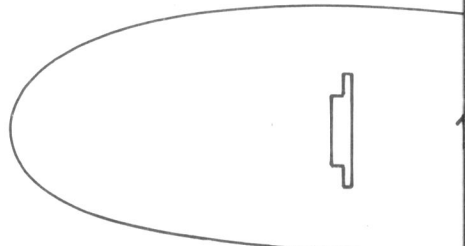
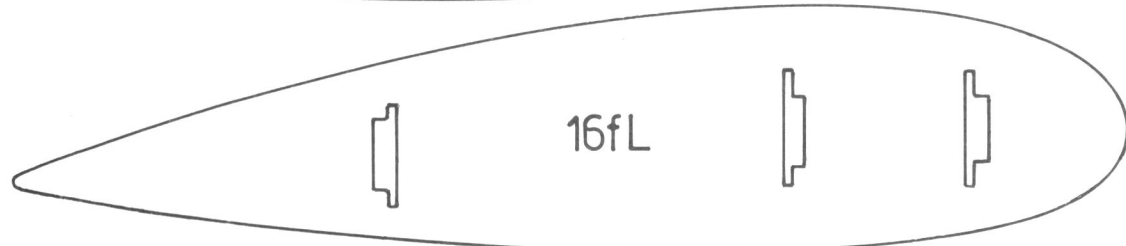
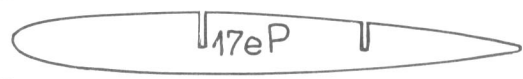
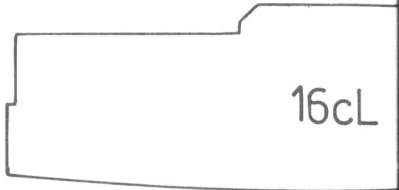
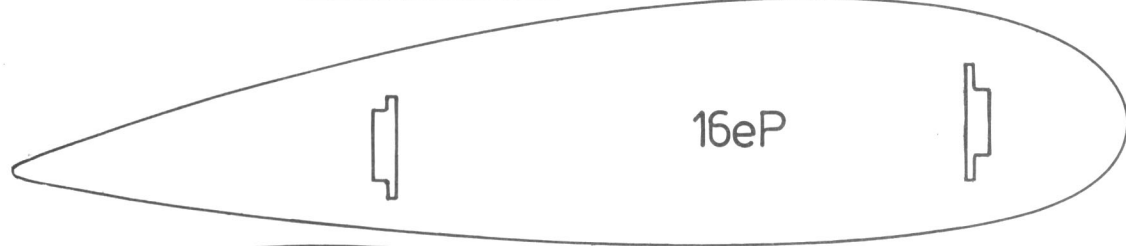
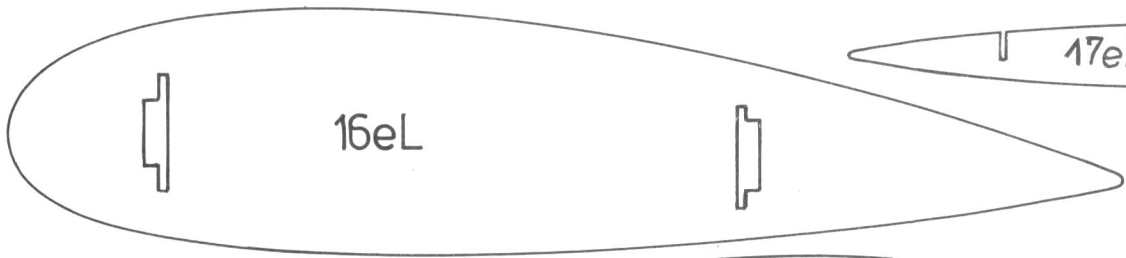
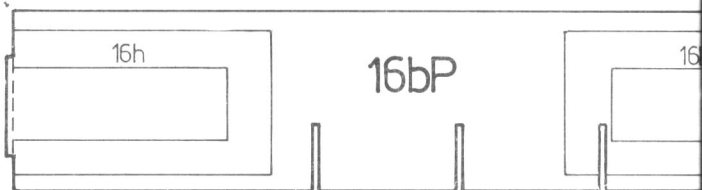
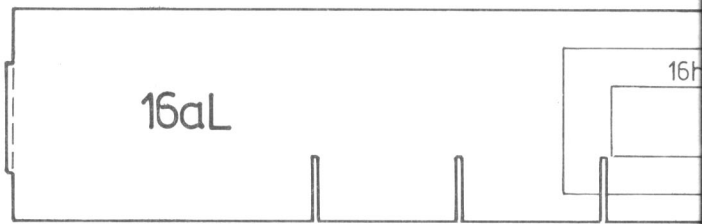
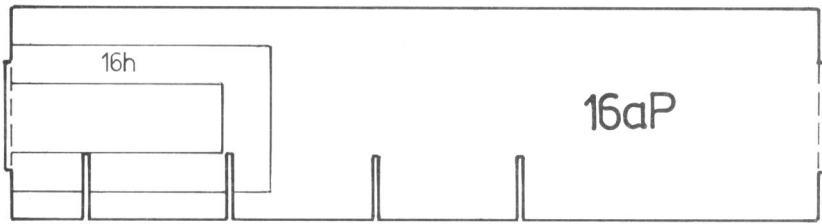
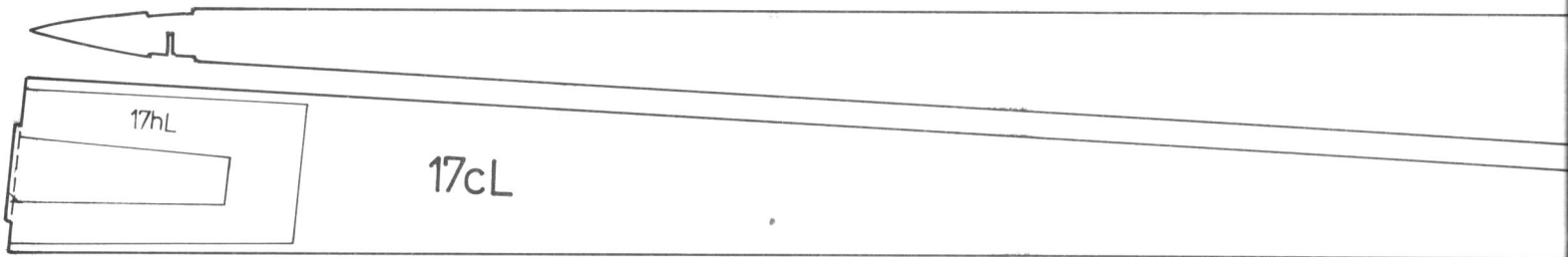
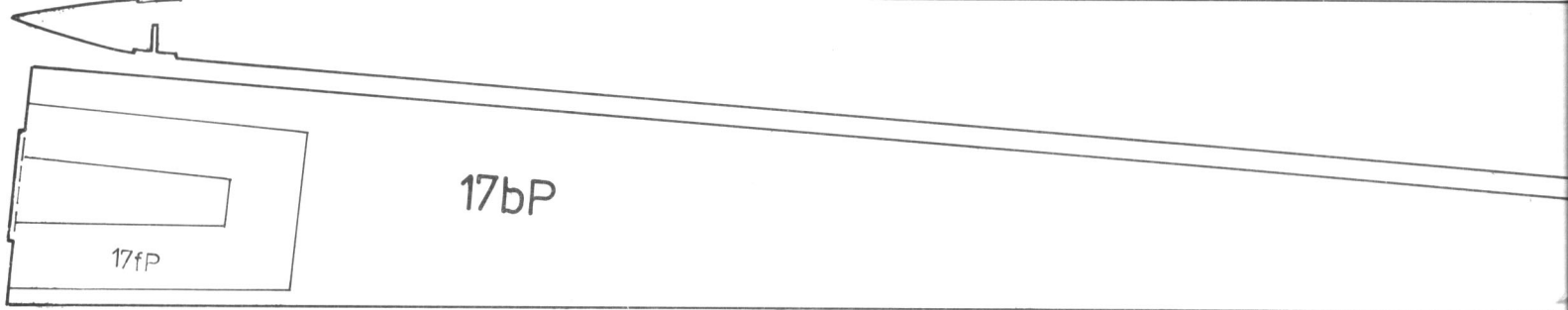

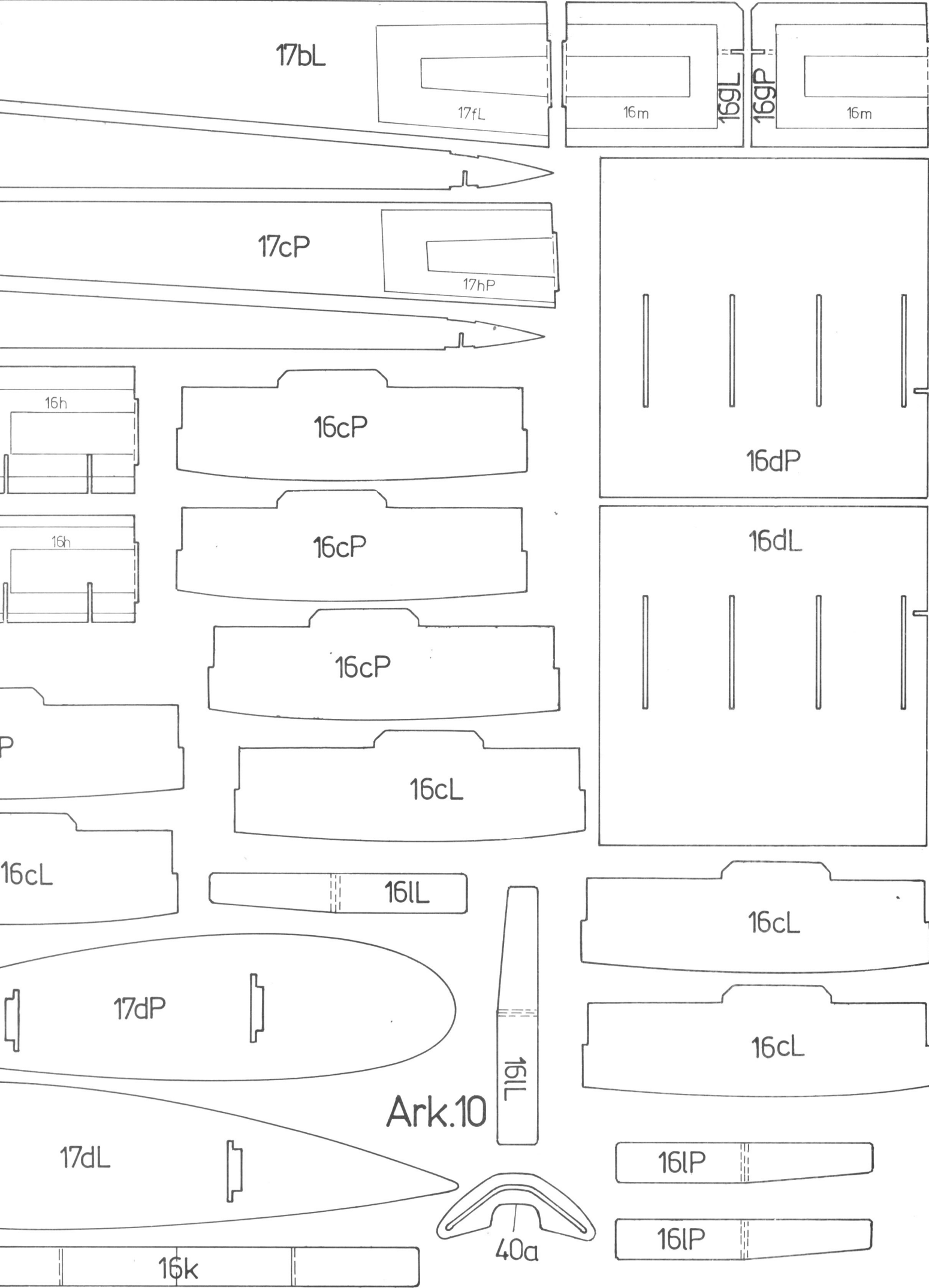

Ark.4

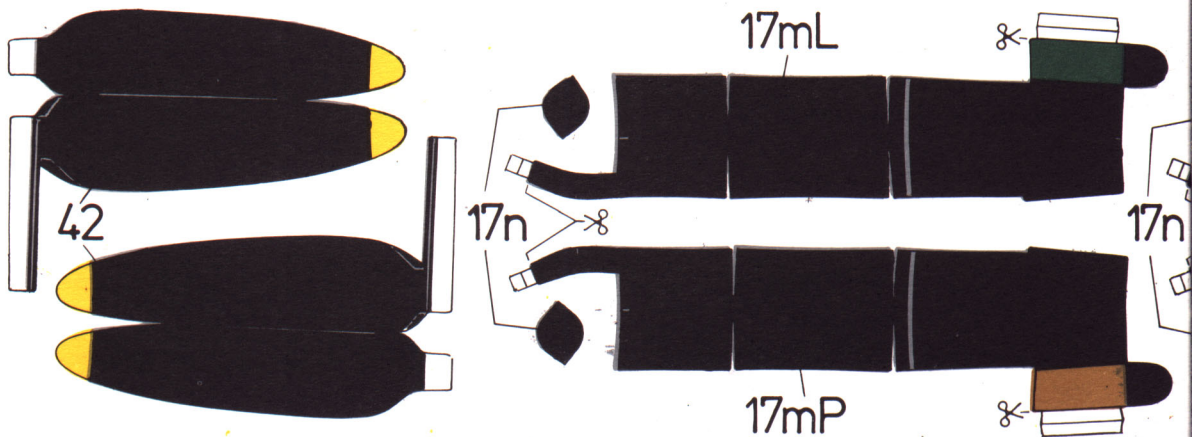
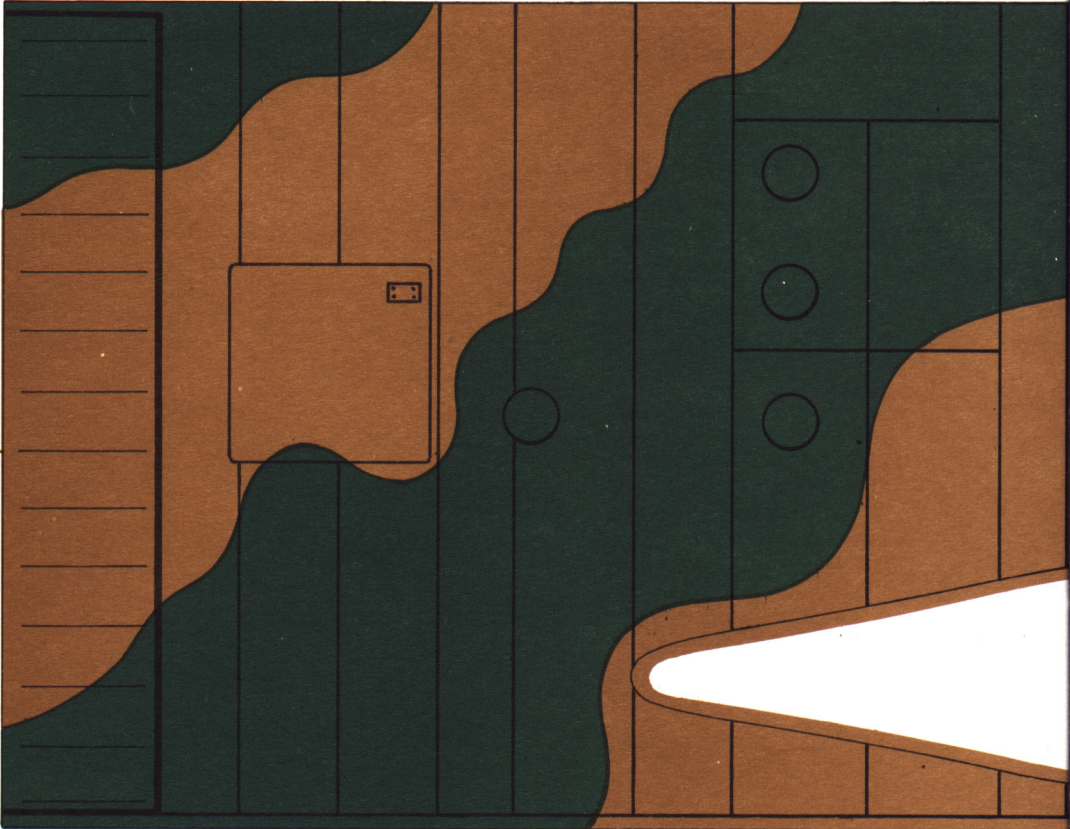
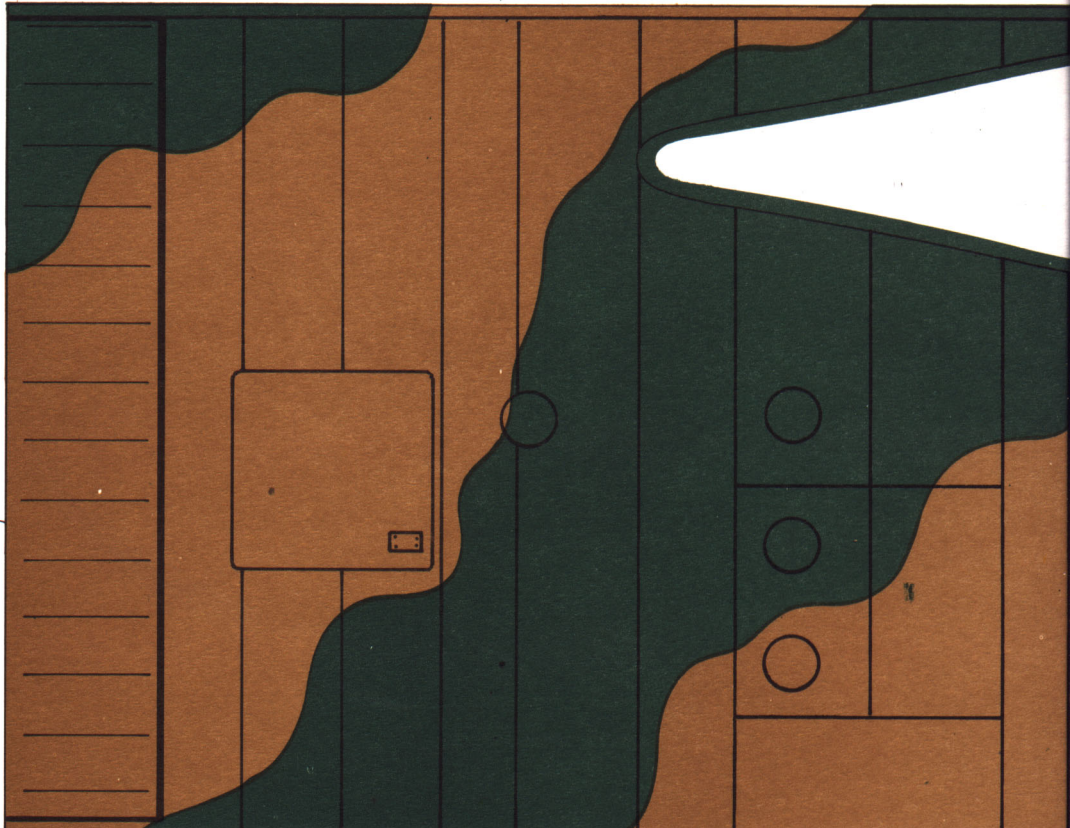
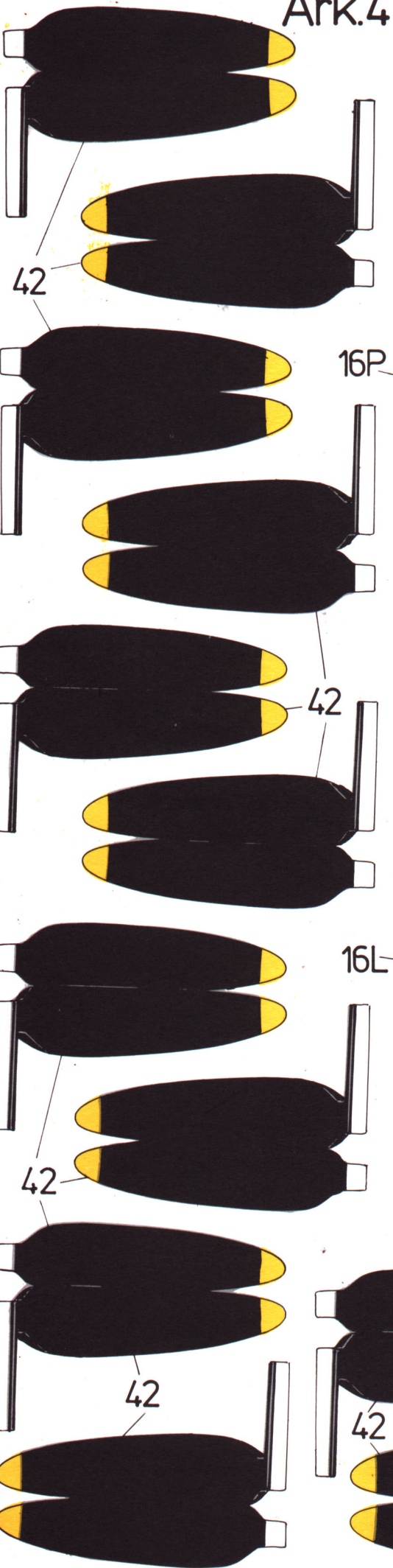

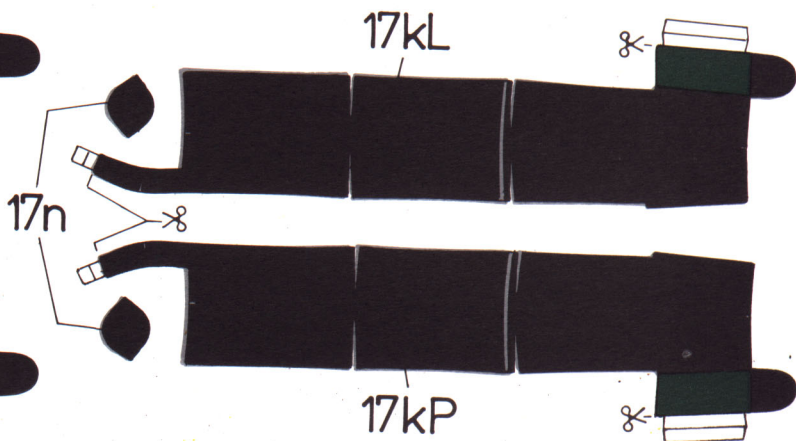
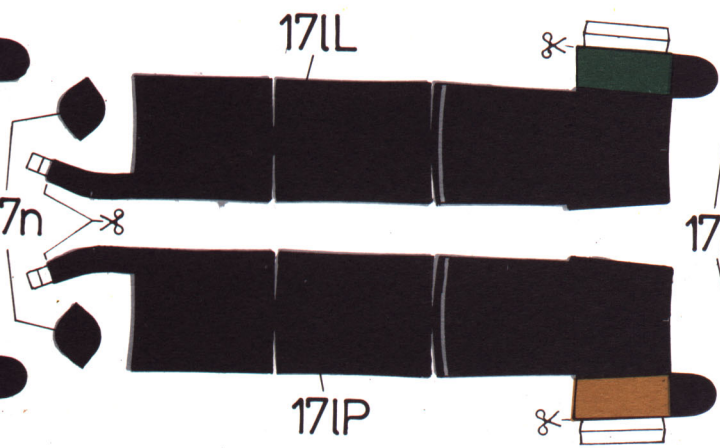
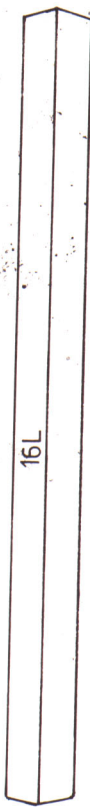
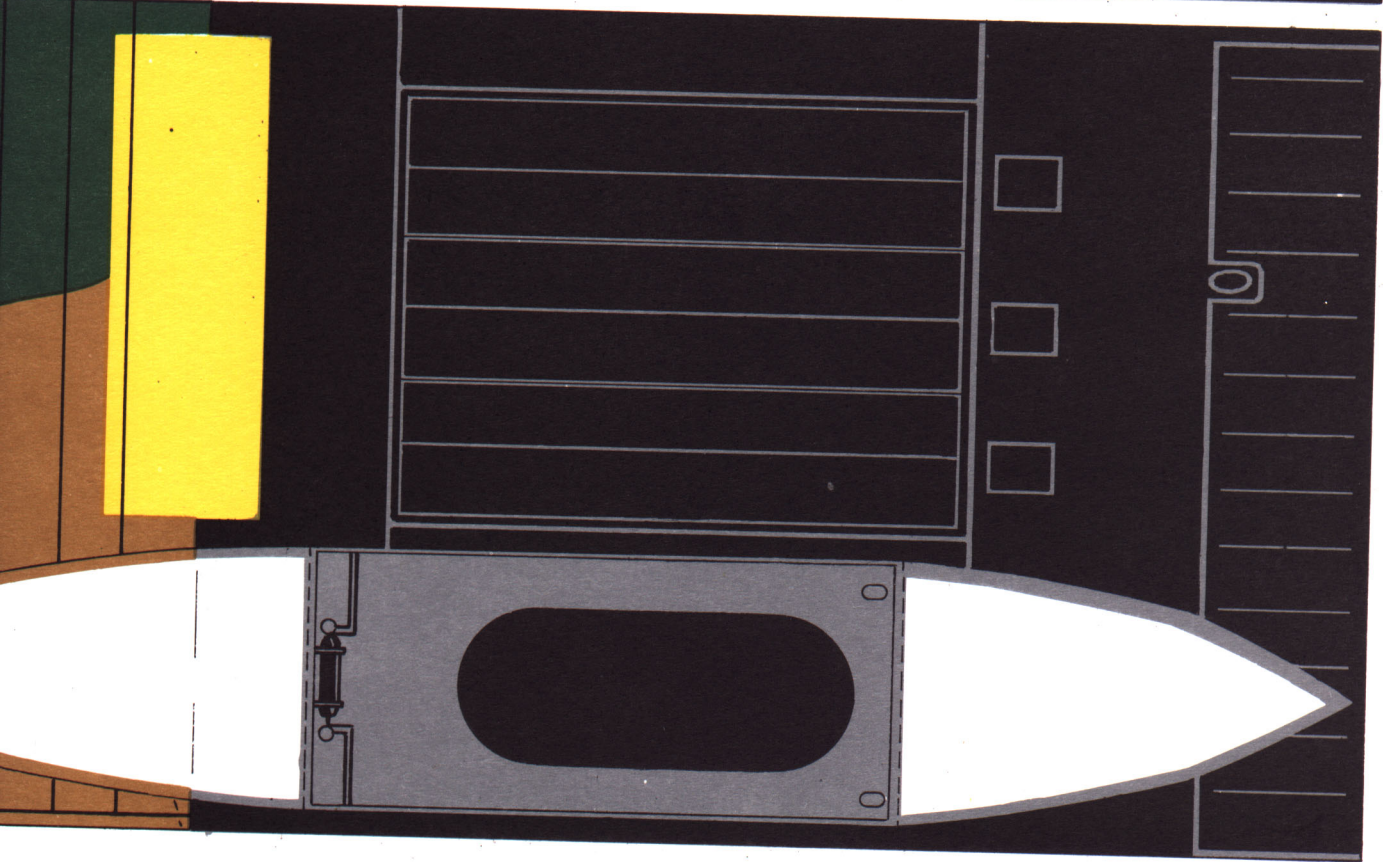
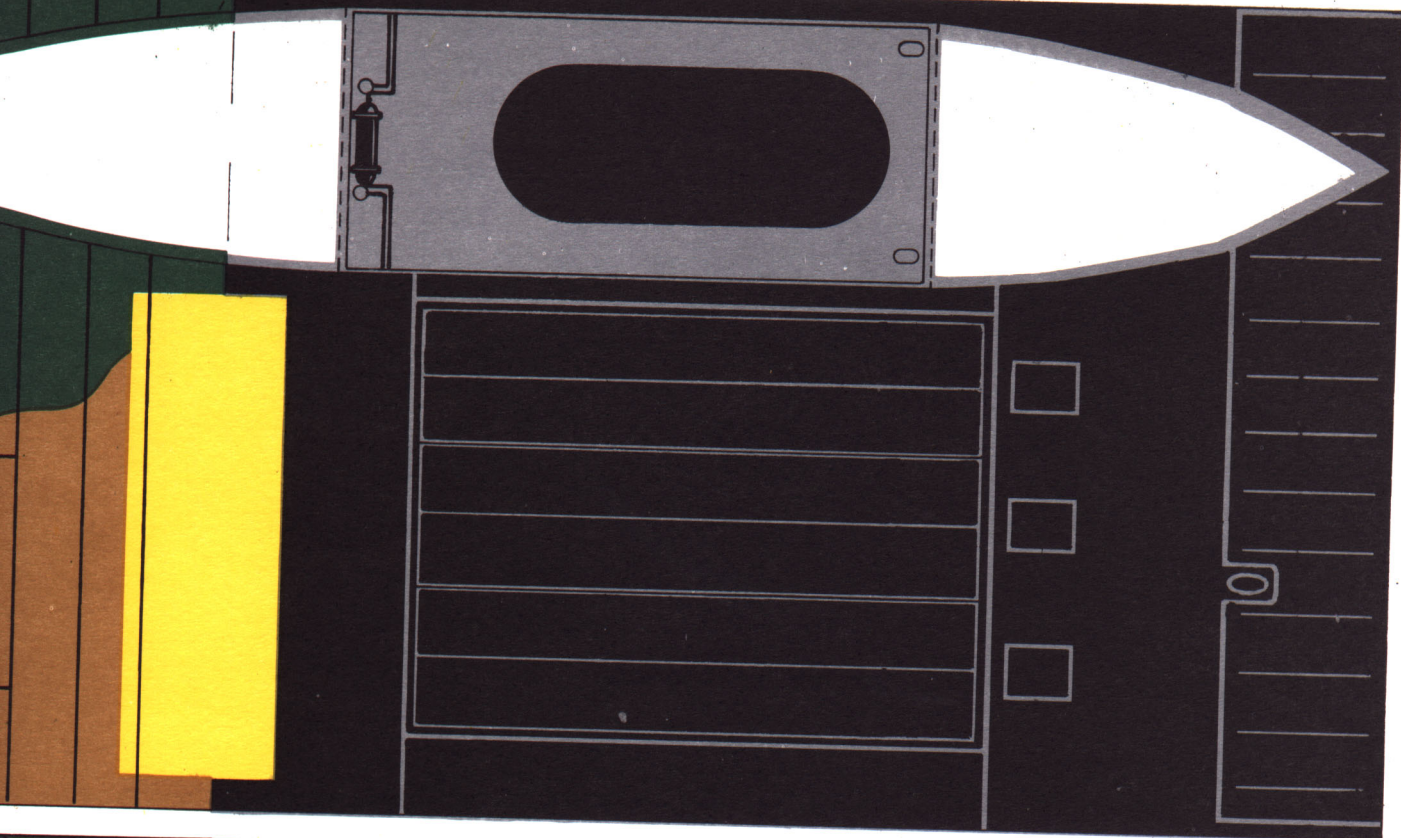

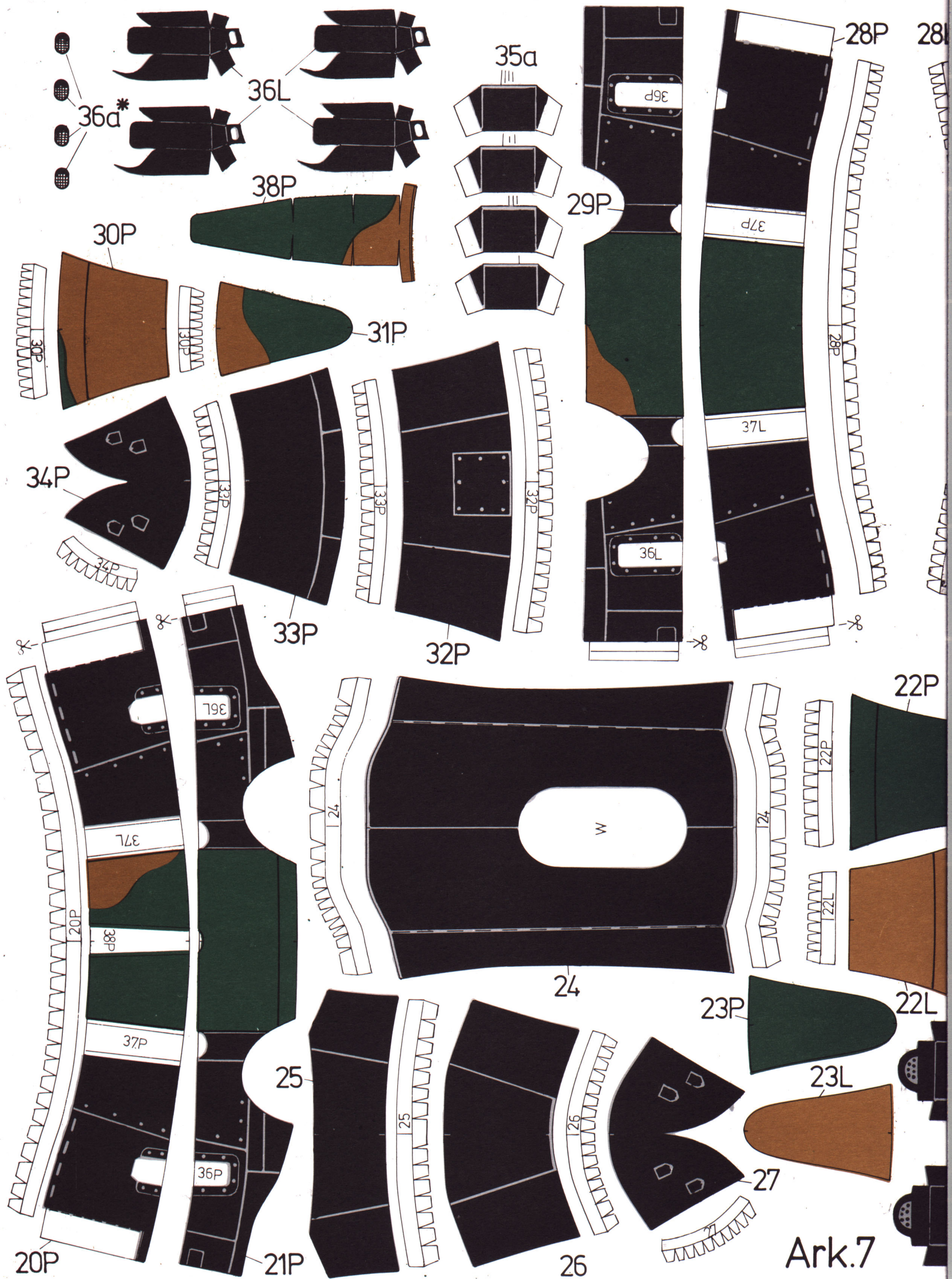

Ark.7

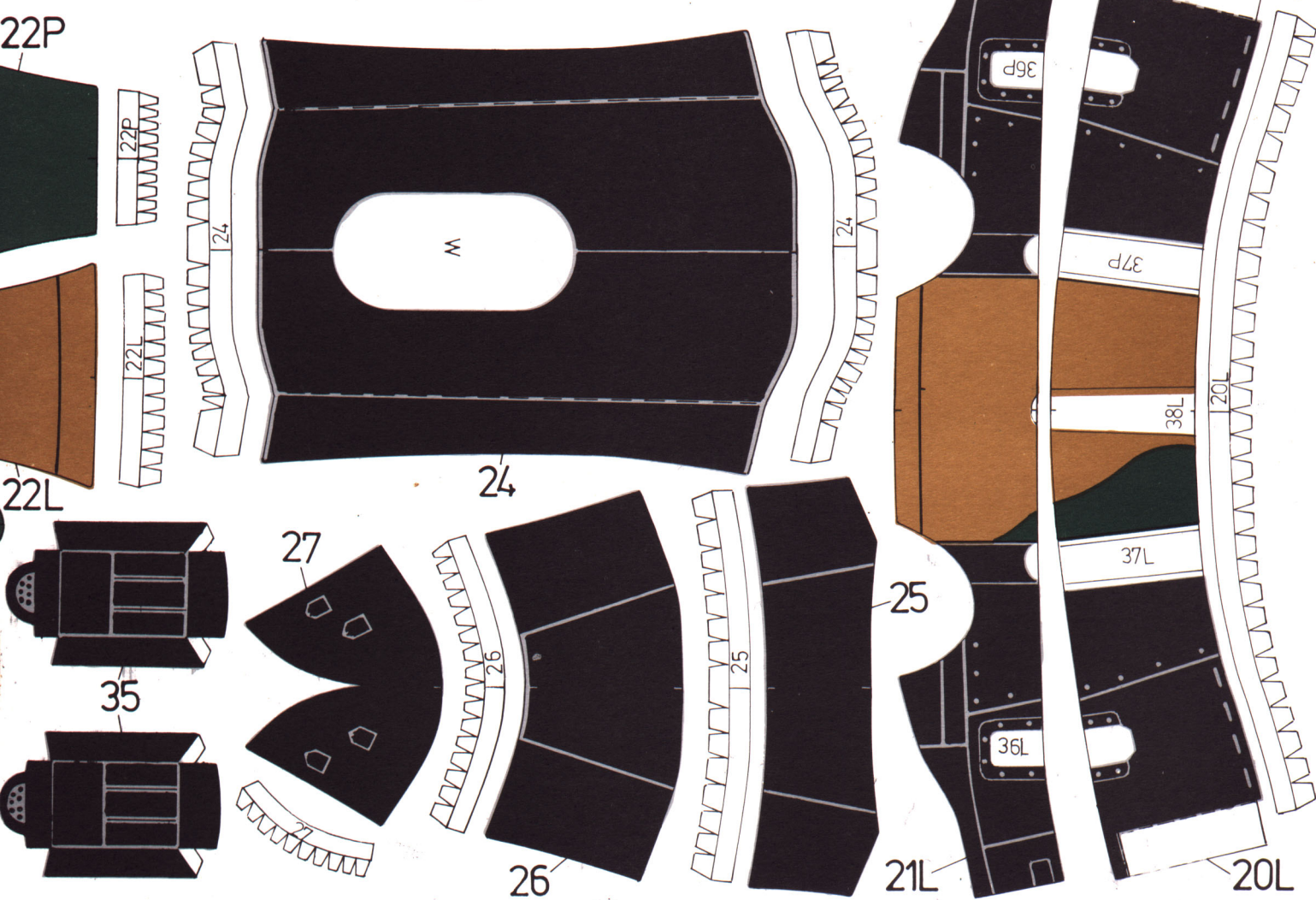
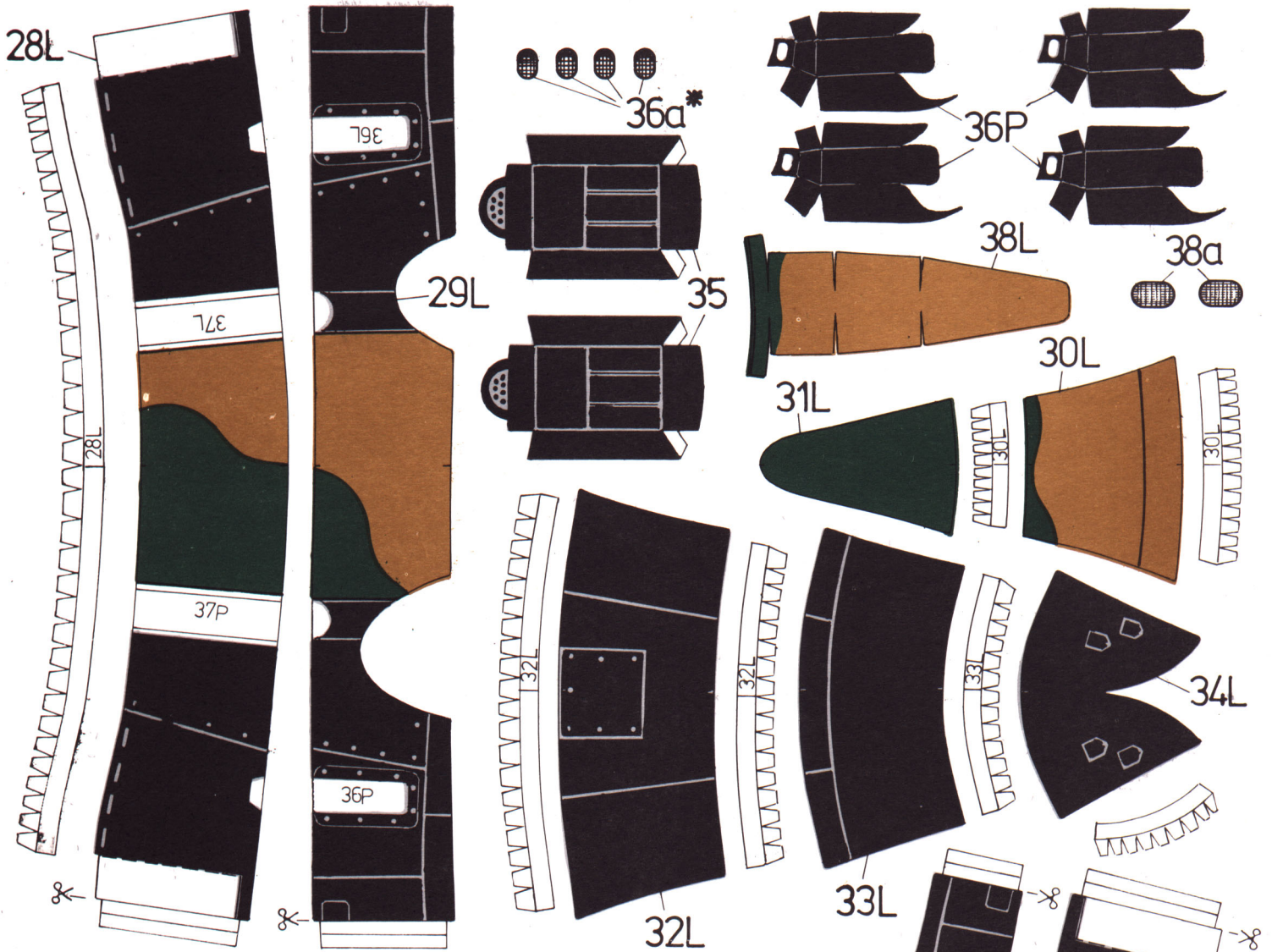

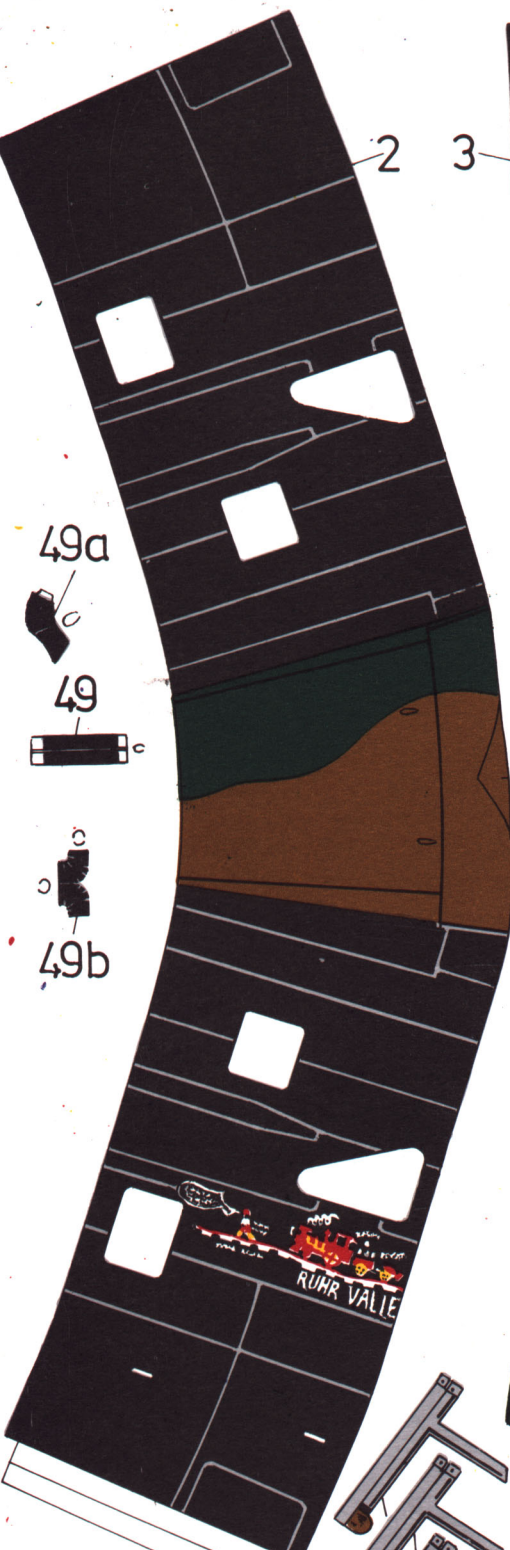

2

3

49a

49

49b

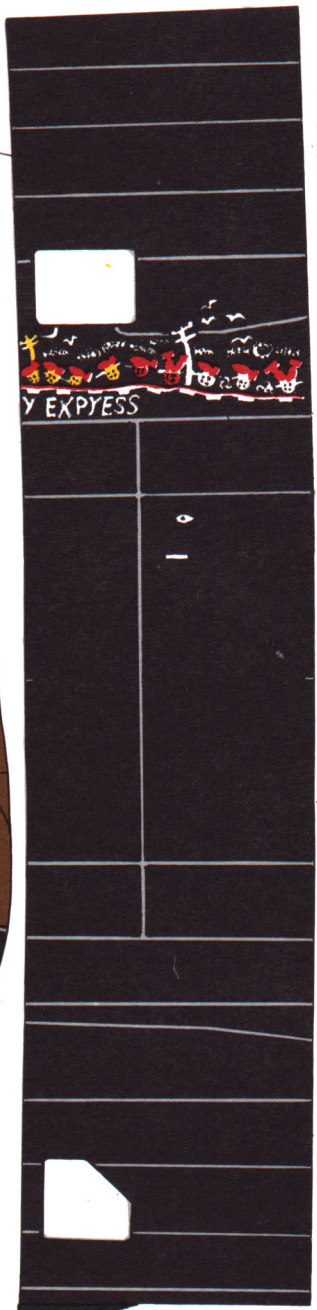

5

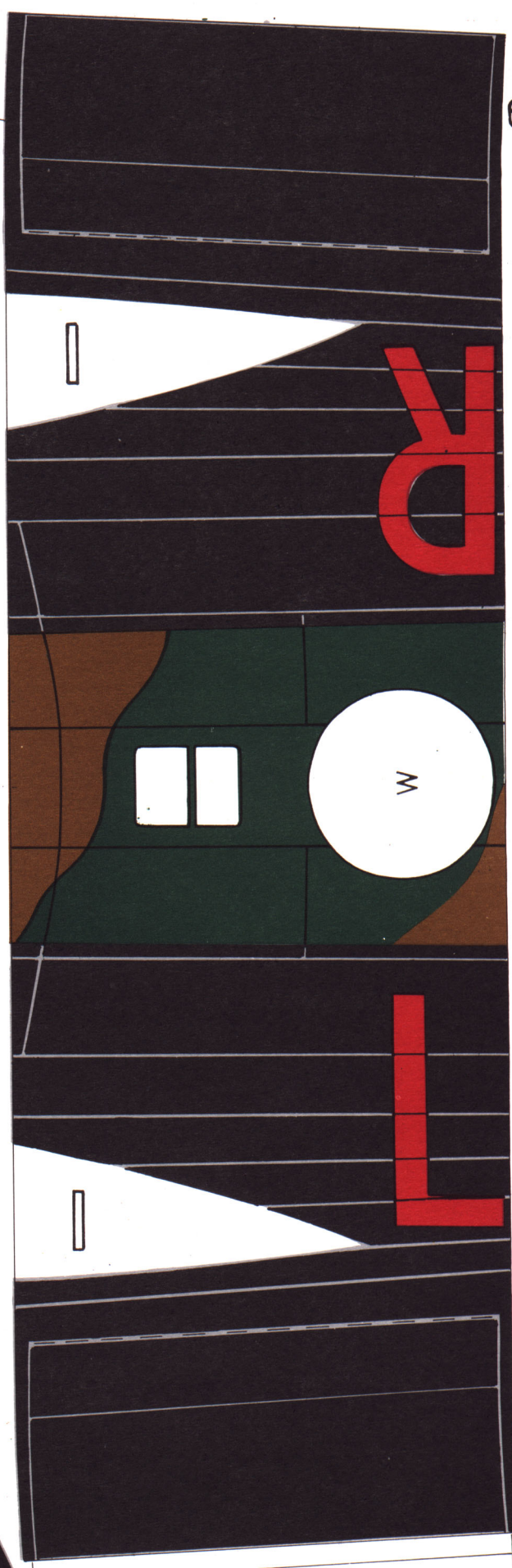

6

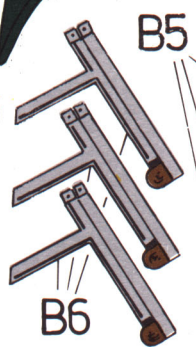
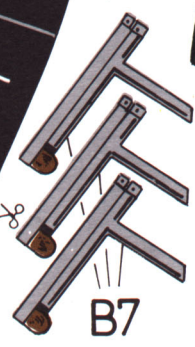
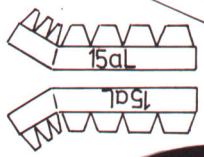

B5

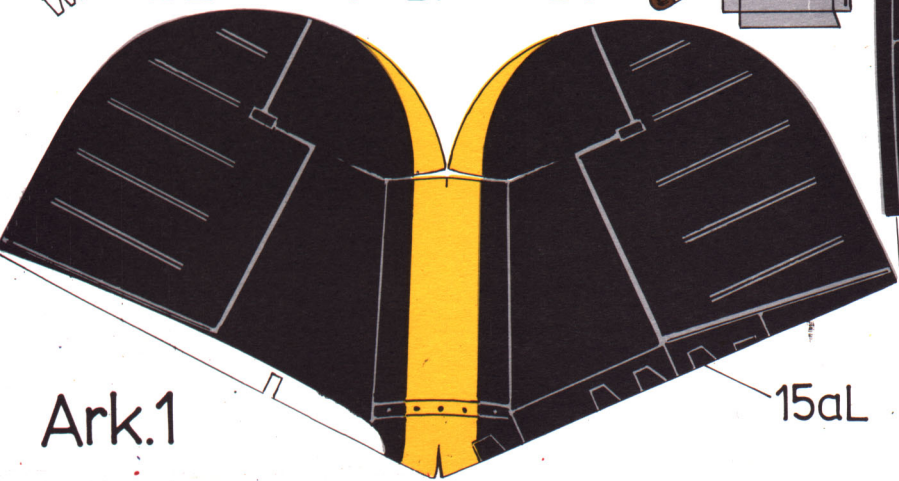
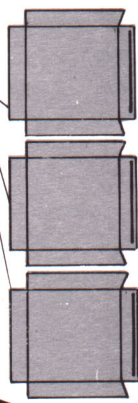

Ark.1

15aL

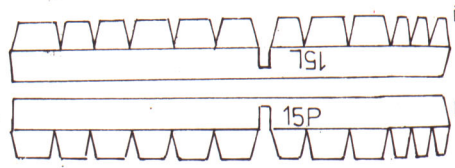

15L

15P

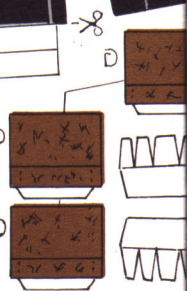

D

D

46

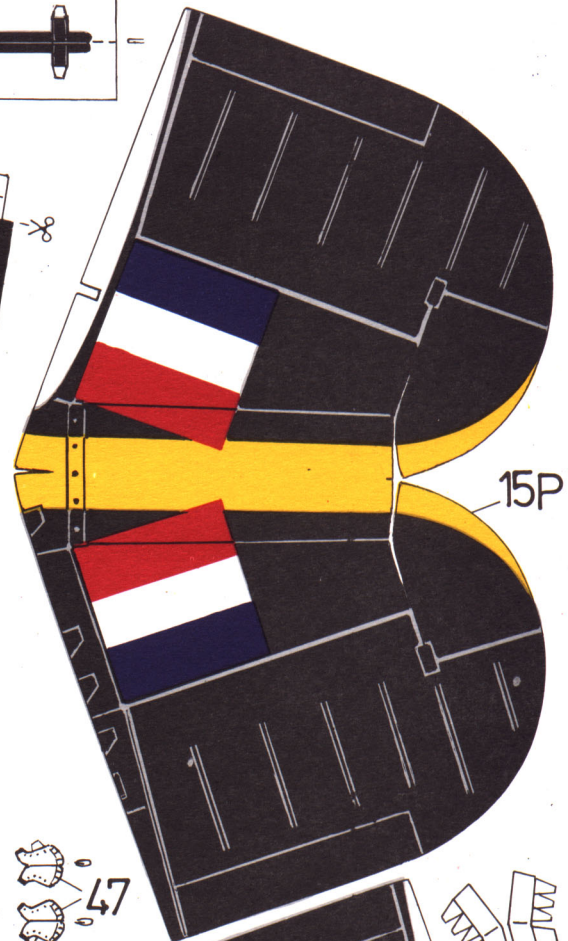
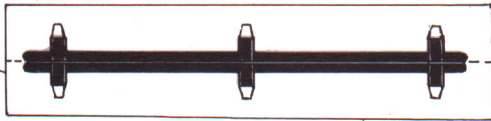

15P



47

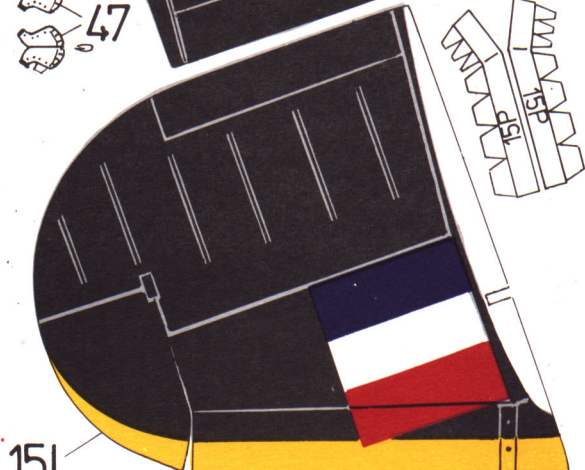

15L

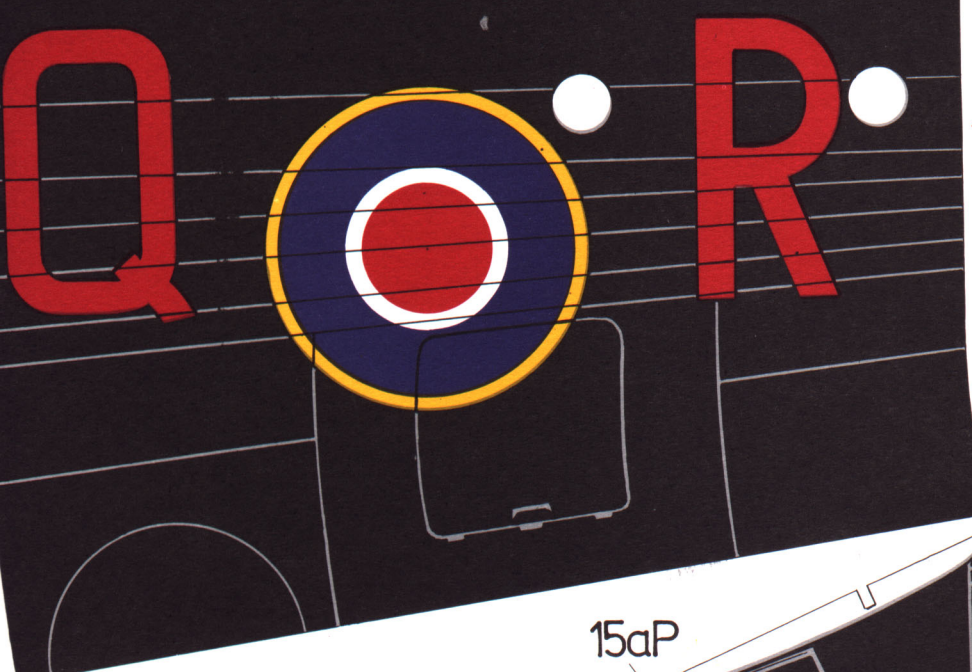

15aP



B8



48

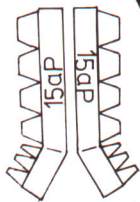
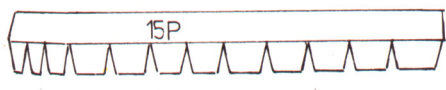
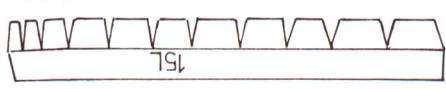

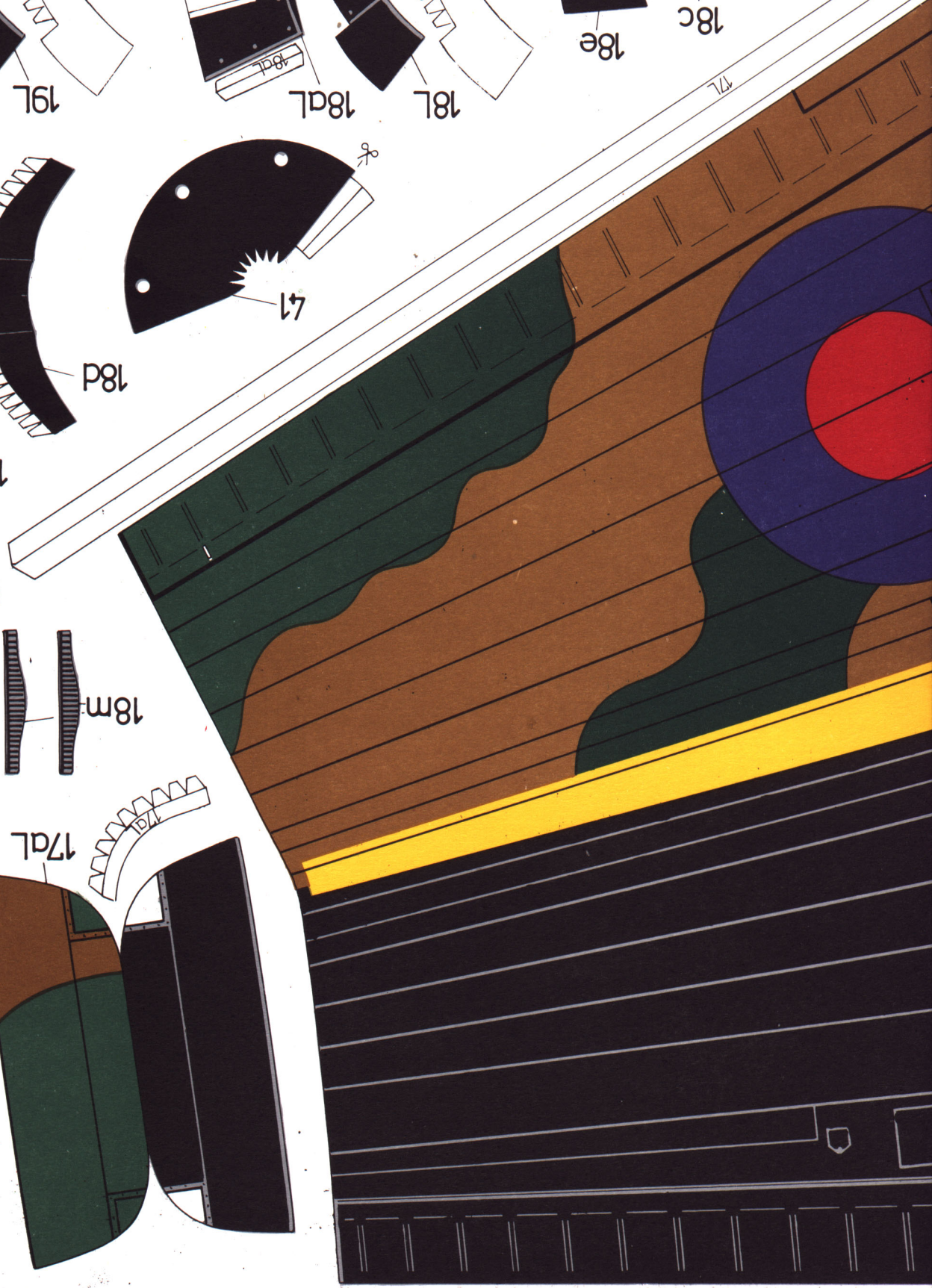
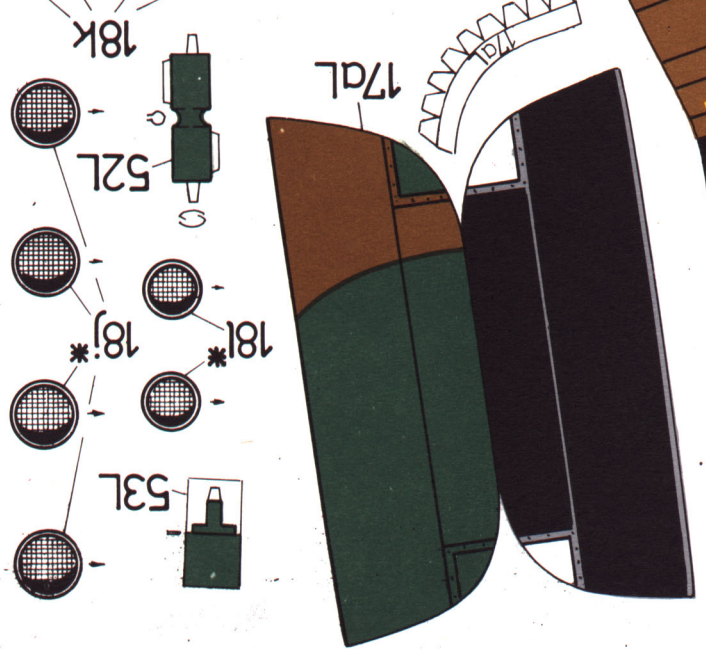
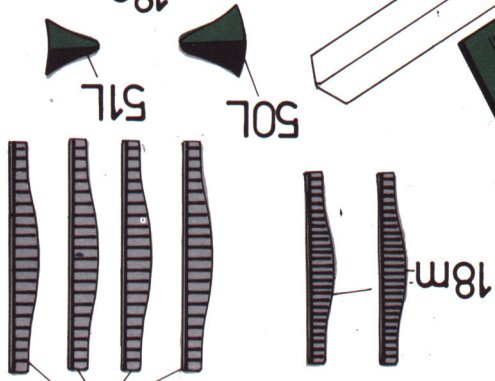
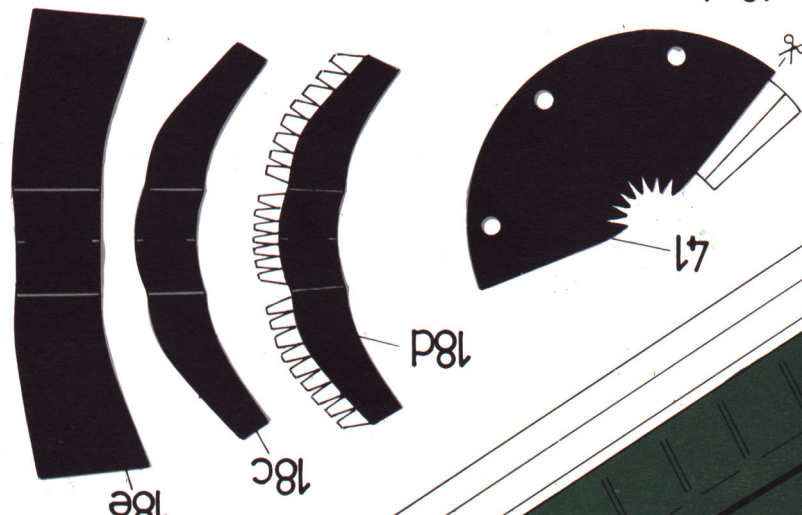
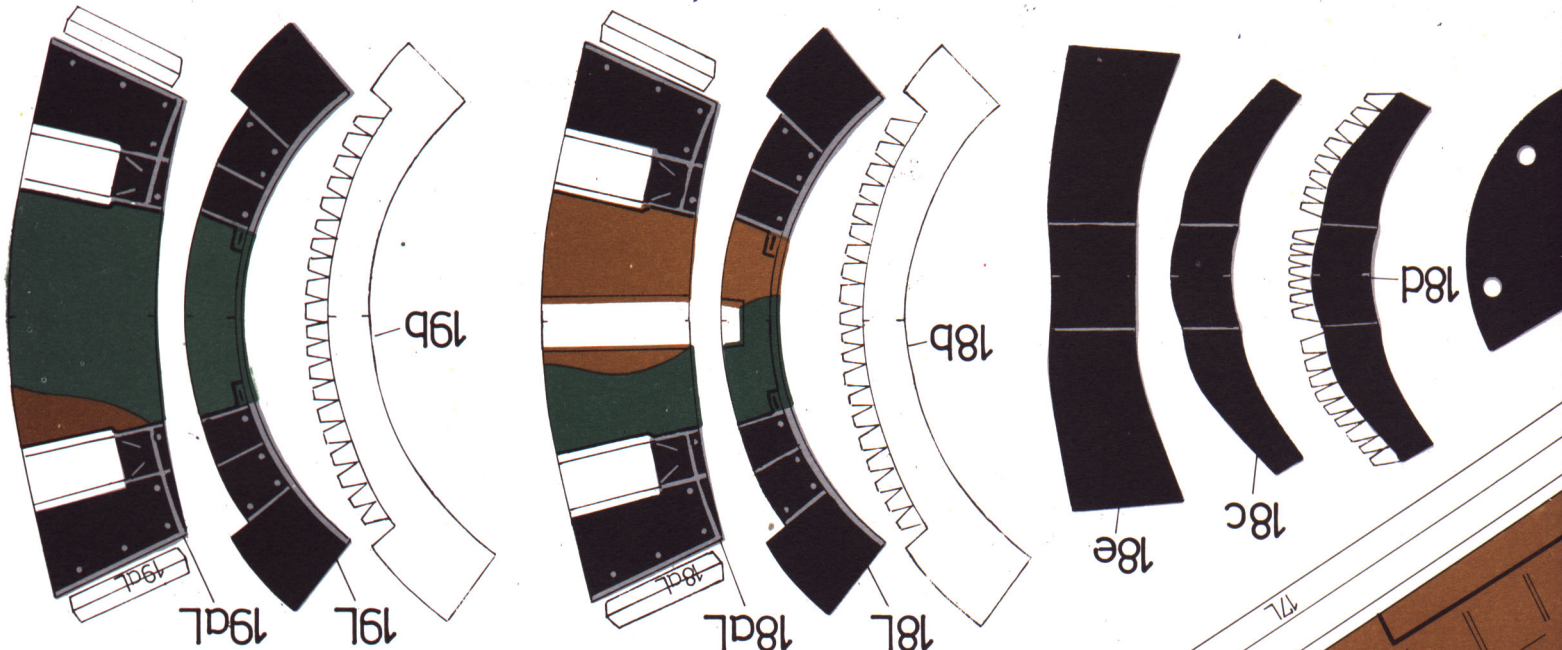

Ark.6

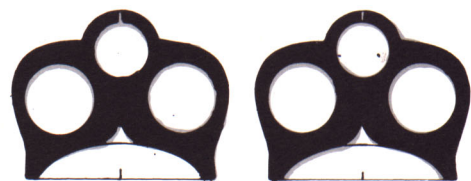
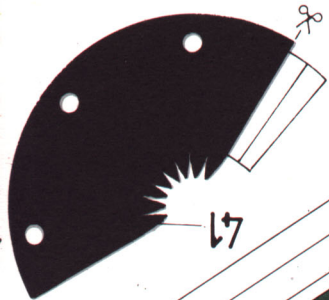

48



49

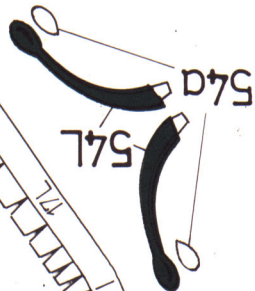

54a

54b

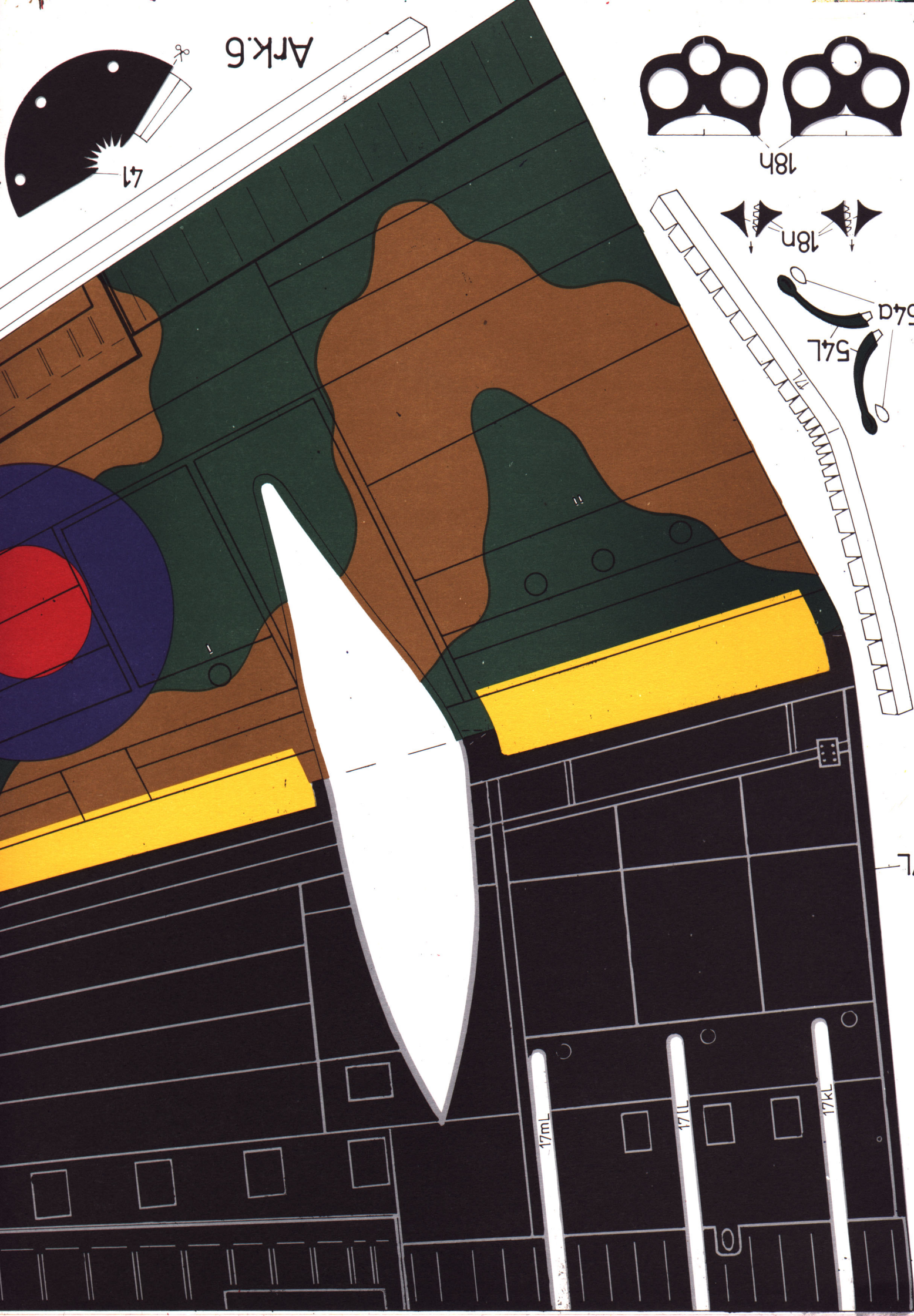

17L

17mL

17L

17kL

Ark.5

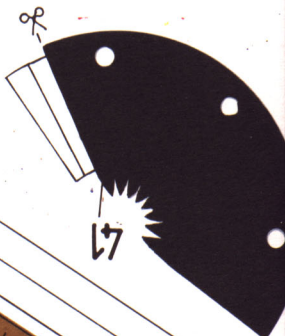

18h



18n

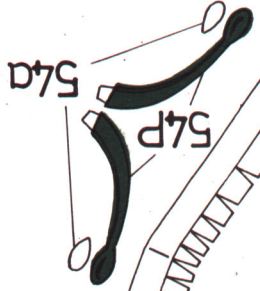

57a

57p

17p

17p

17kP

17lP

17mP

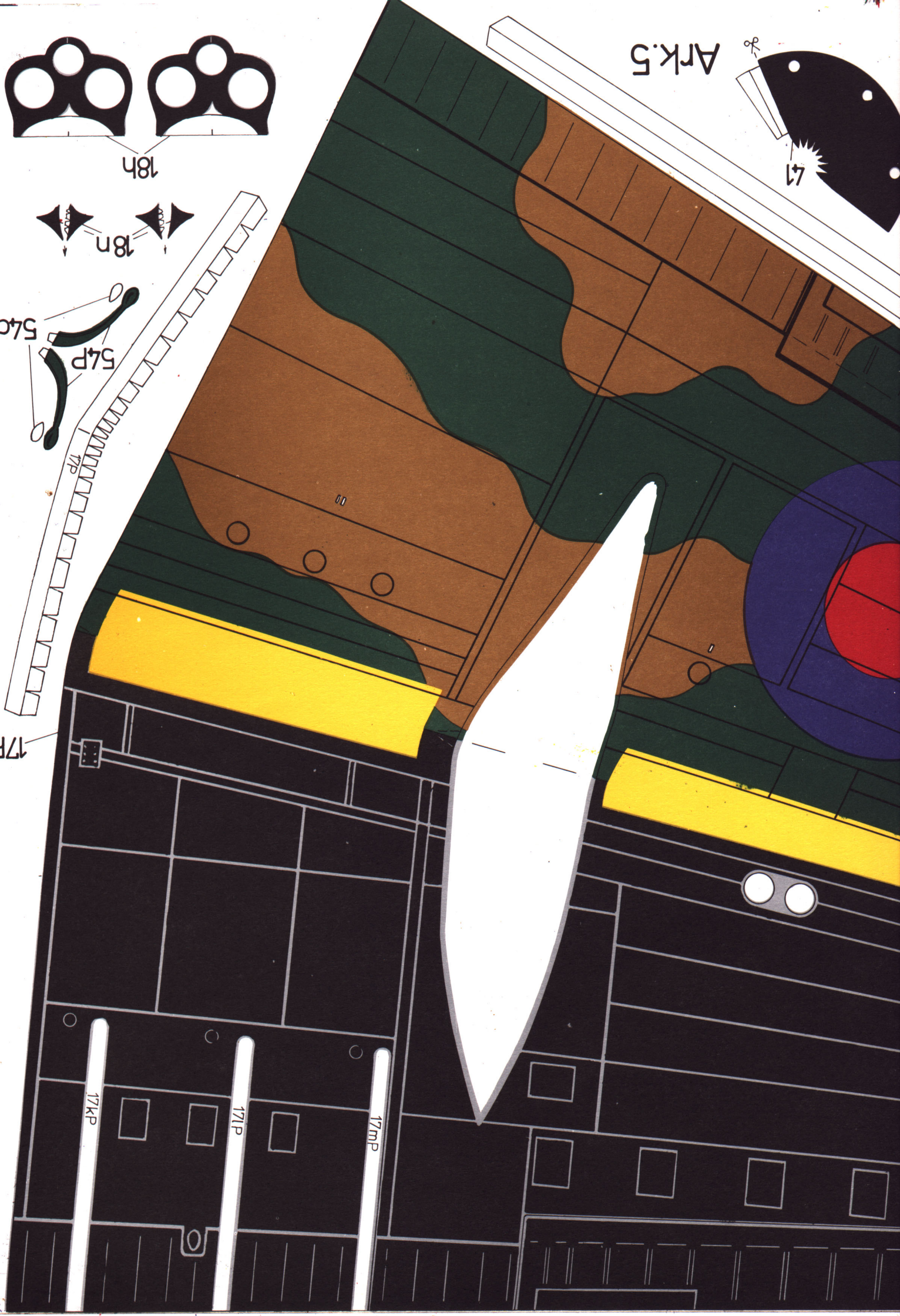

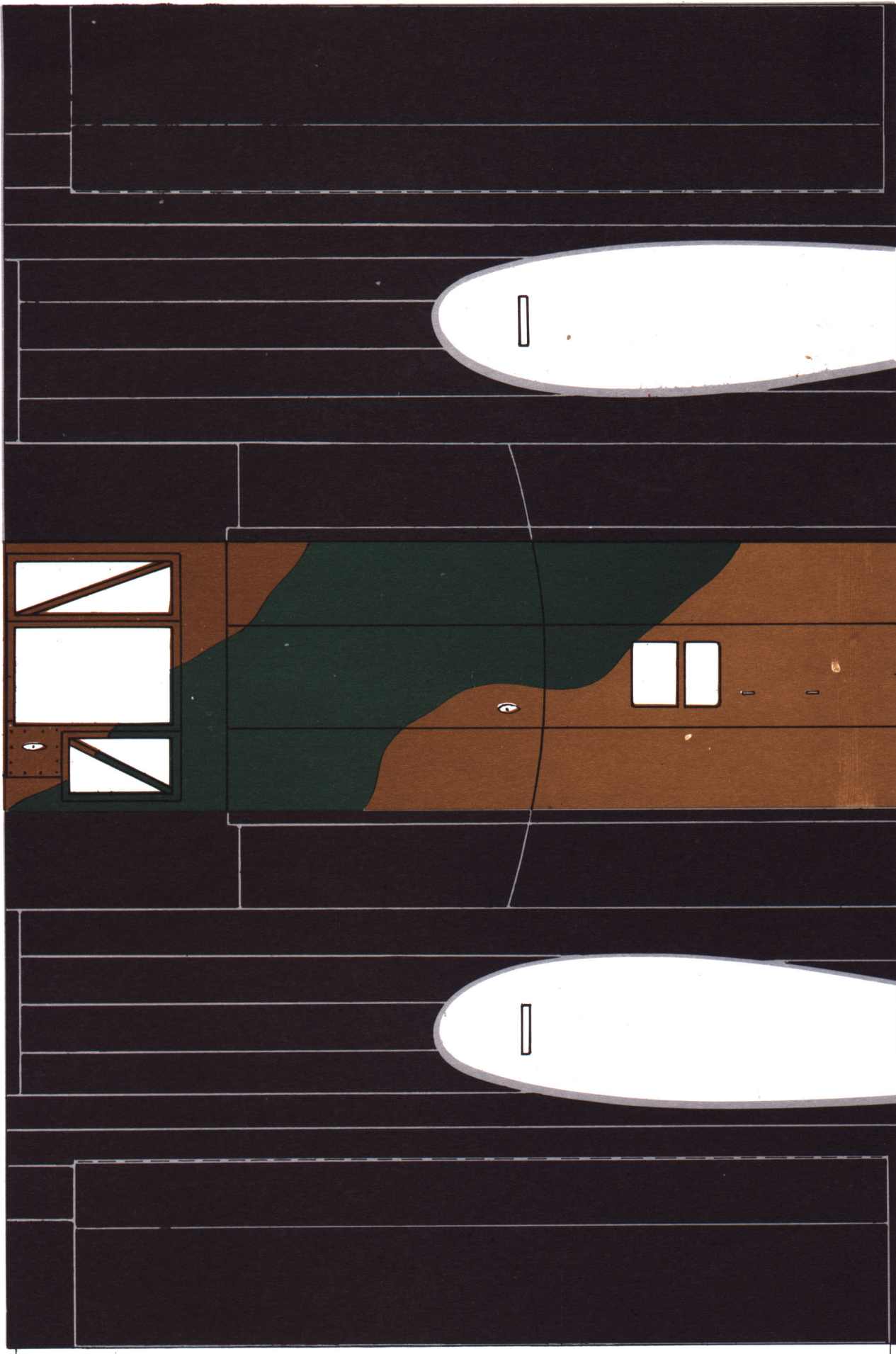

4

W7710

W7710

8

9cP

9cL

8

43

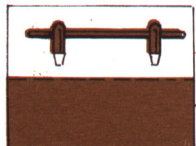

45

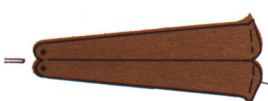

44



43a

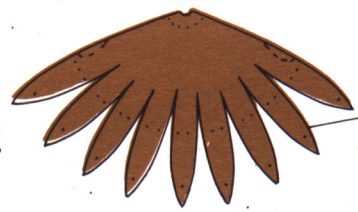

43

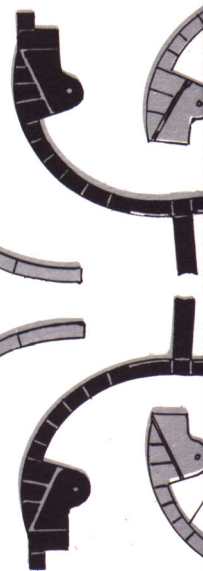

Ark.2

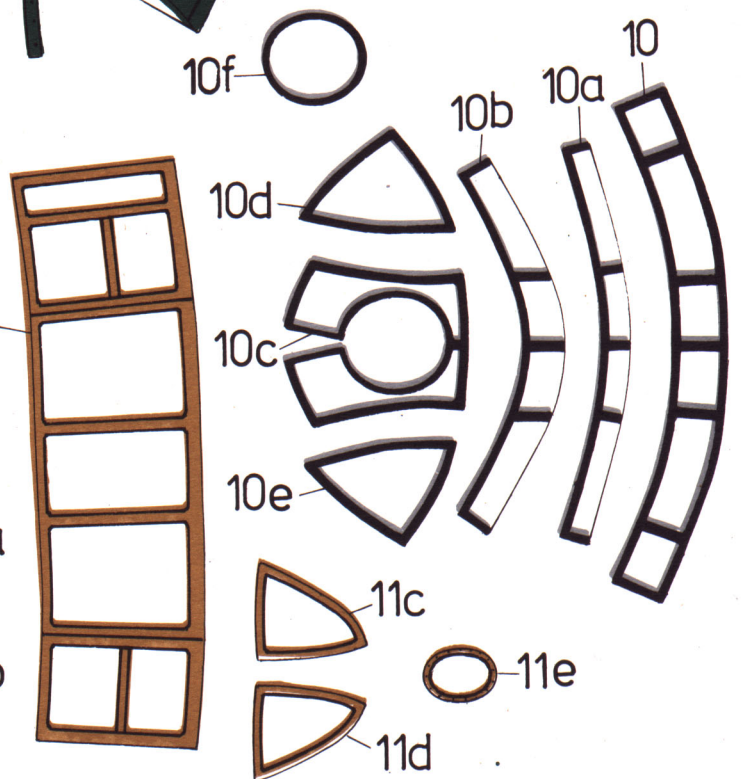
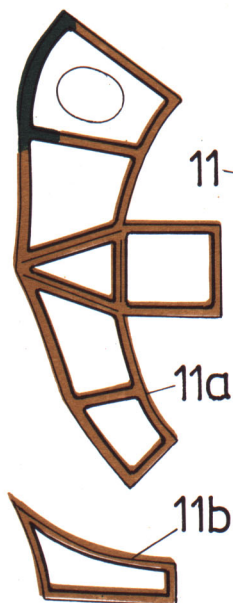
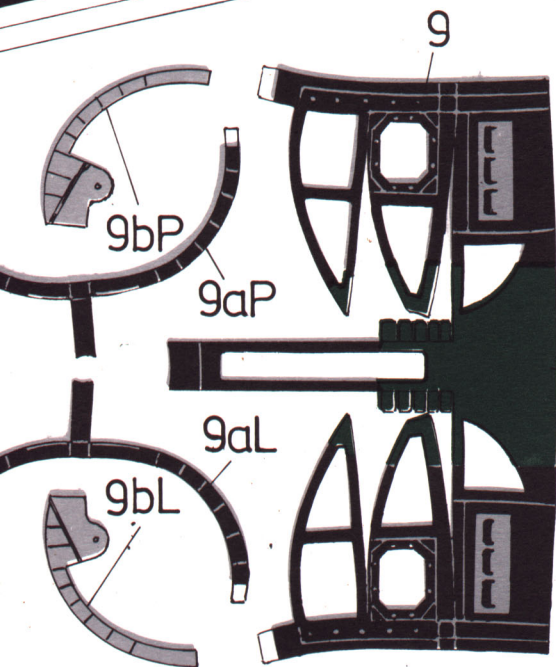
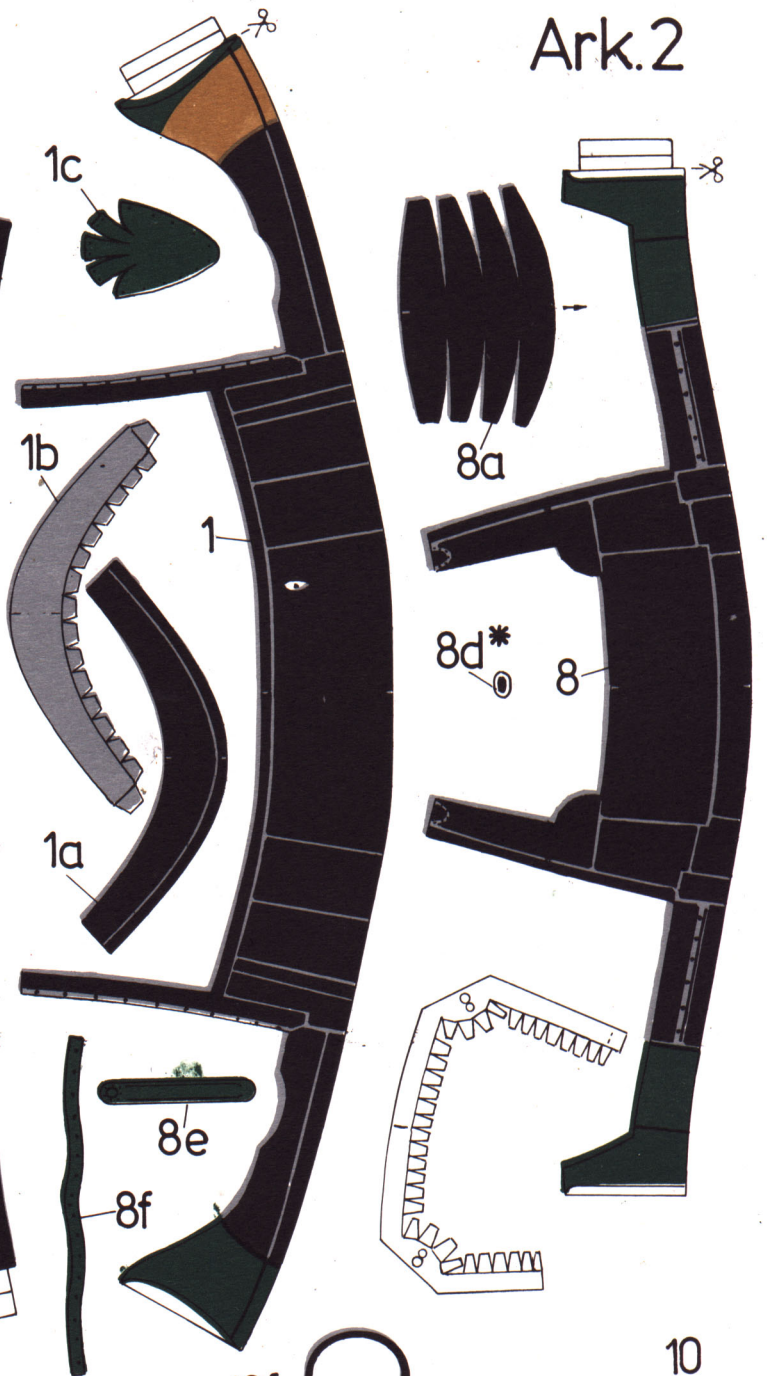
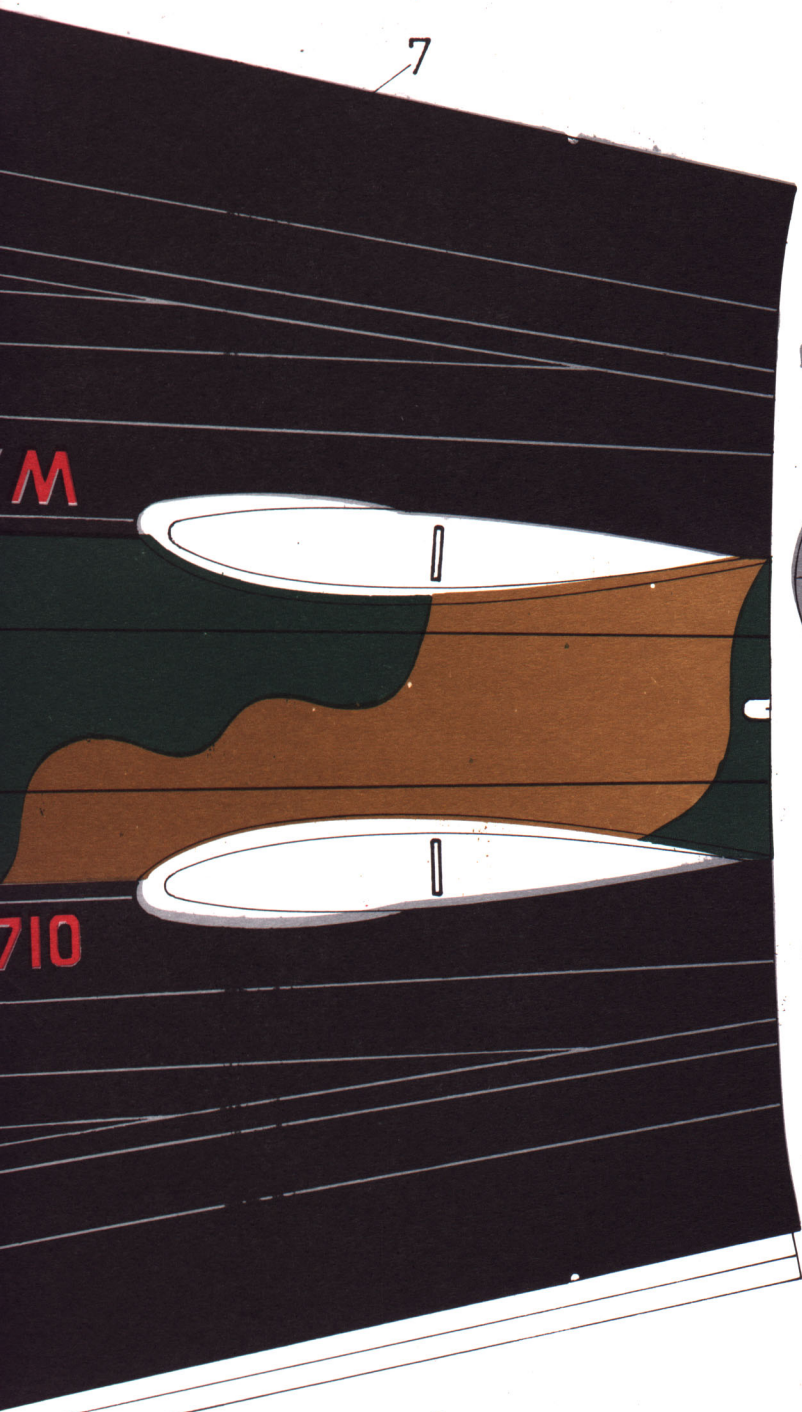

Ark.3

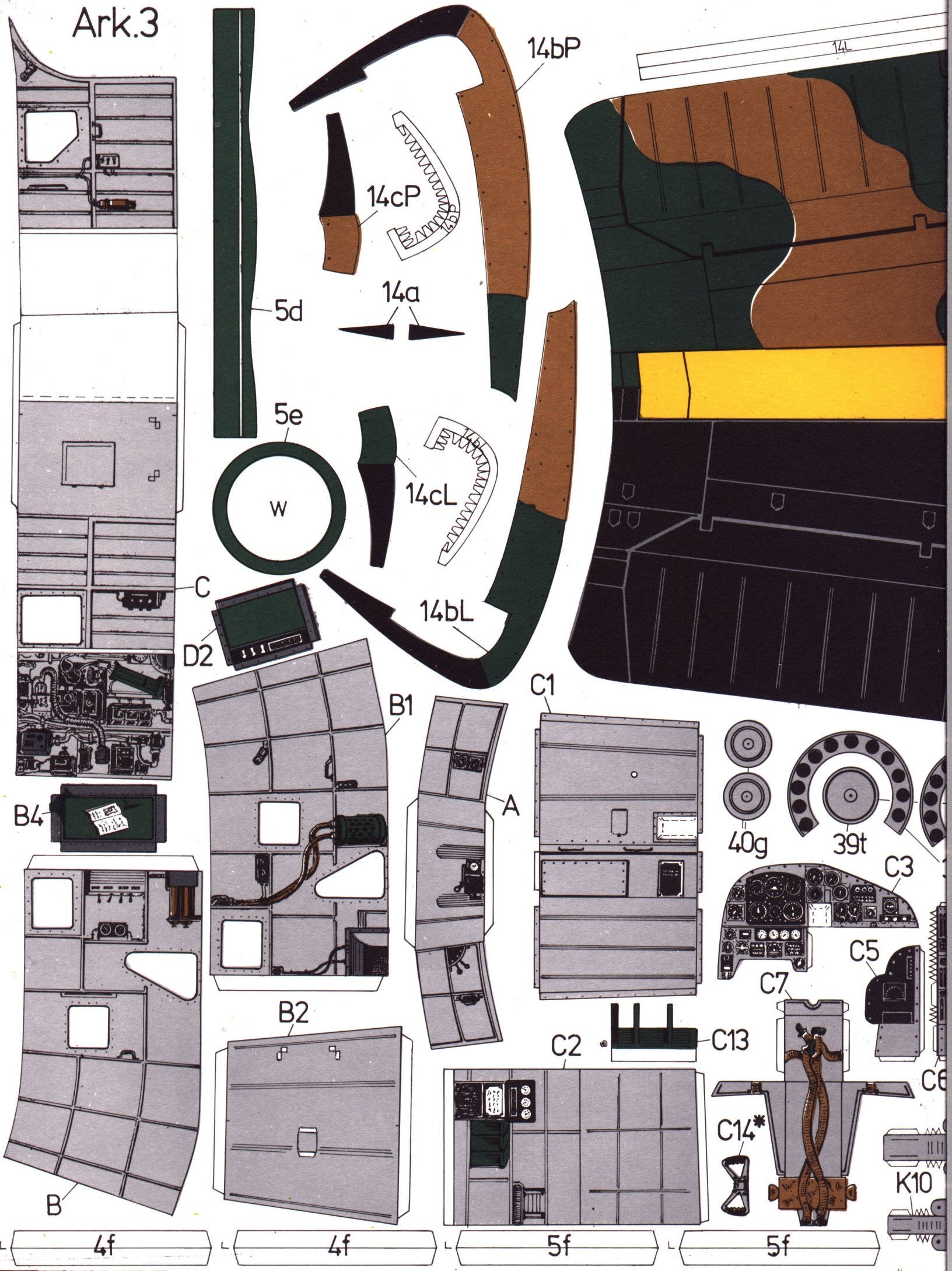

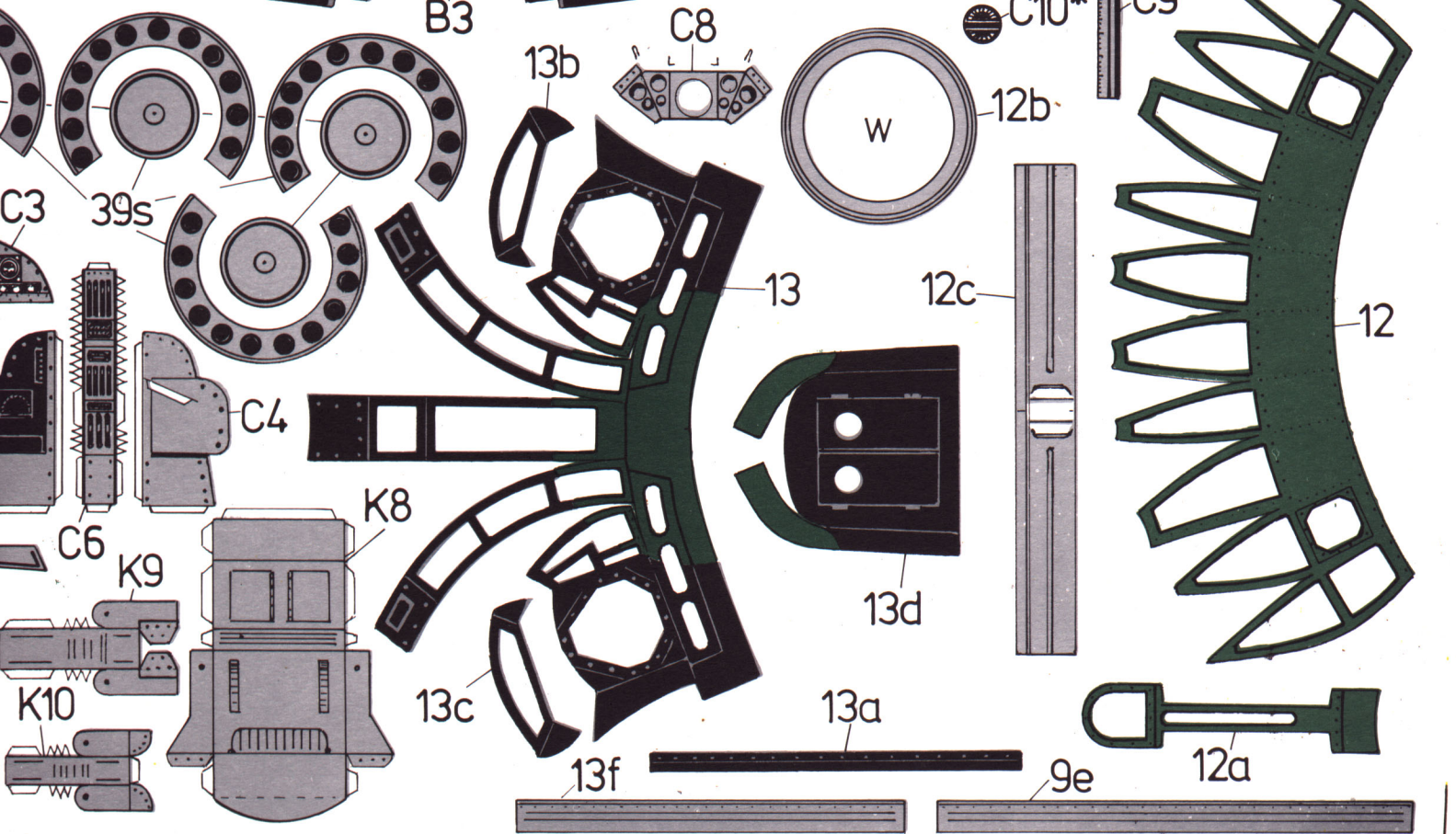
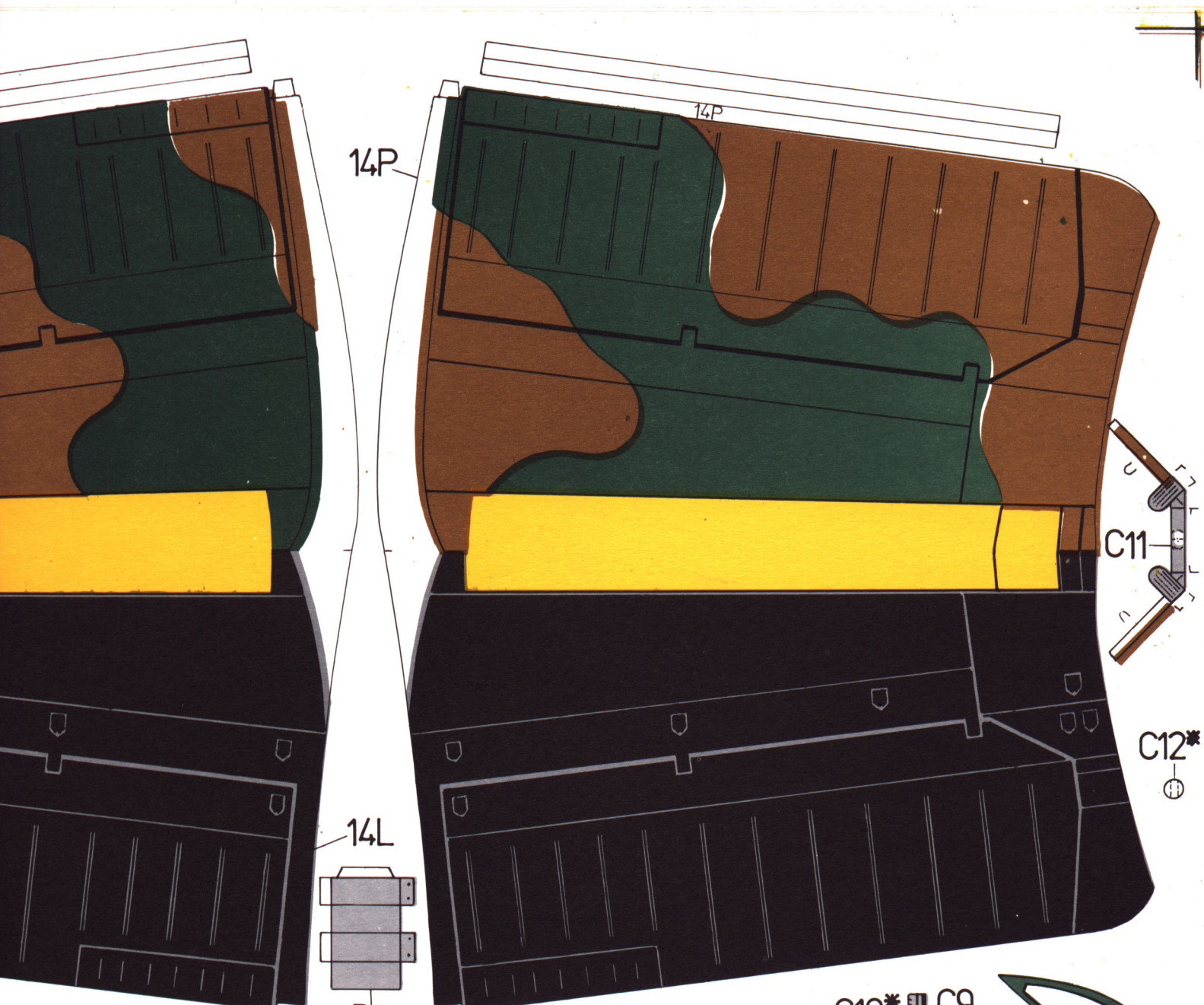

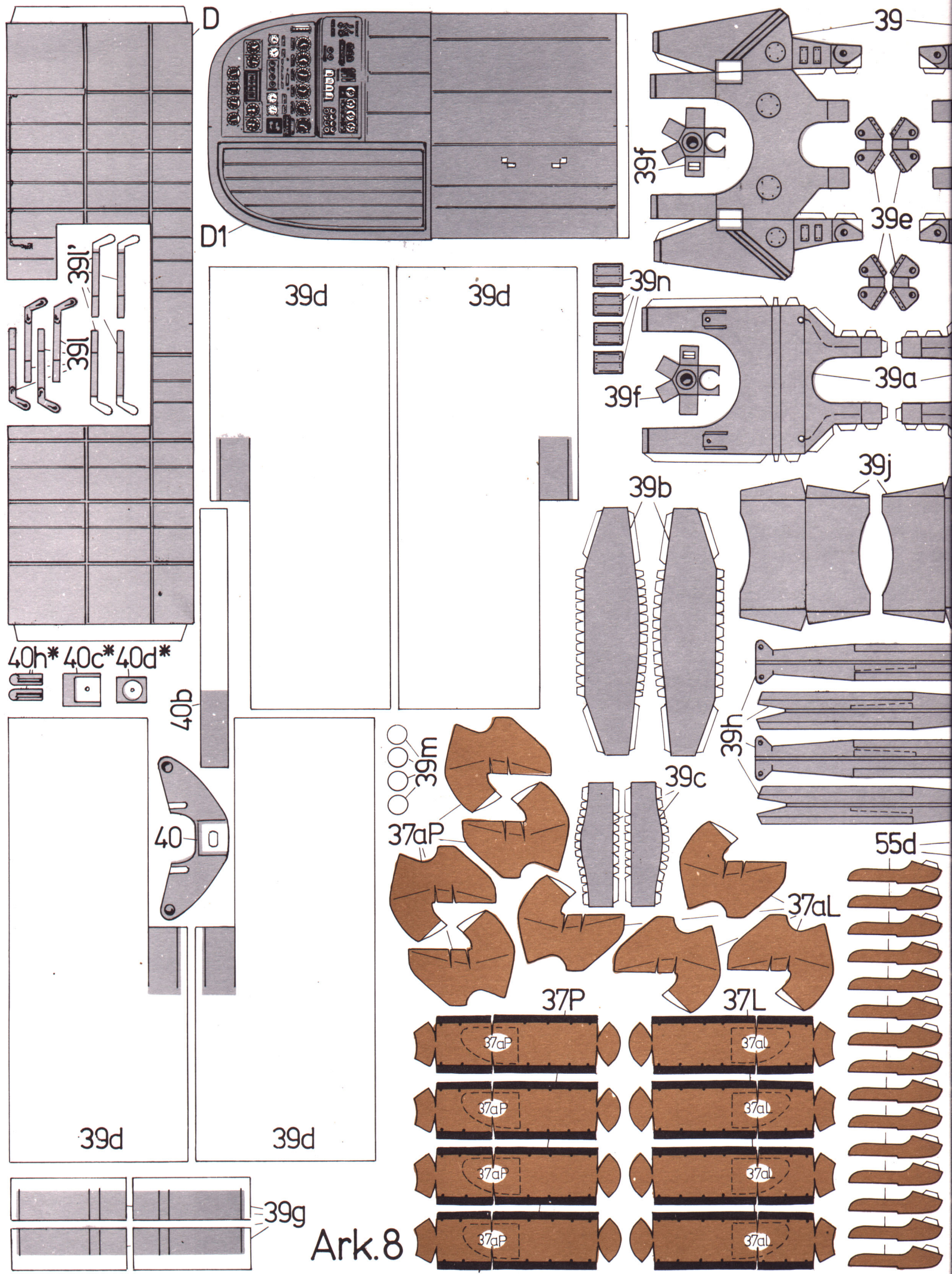

Ark.8

