

# SR-71

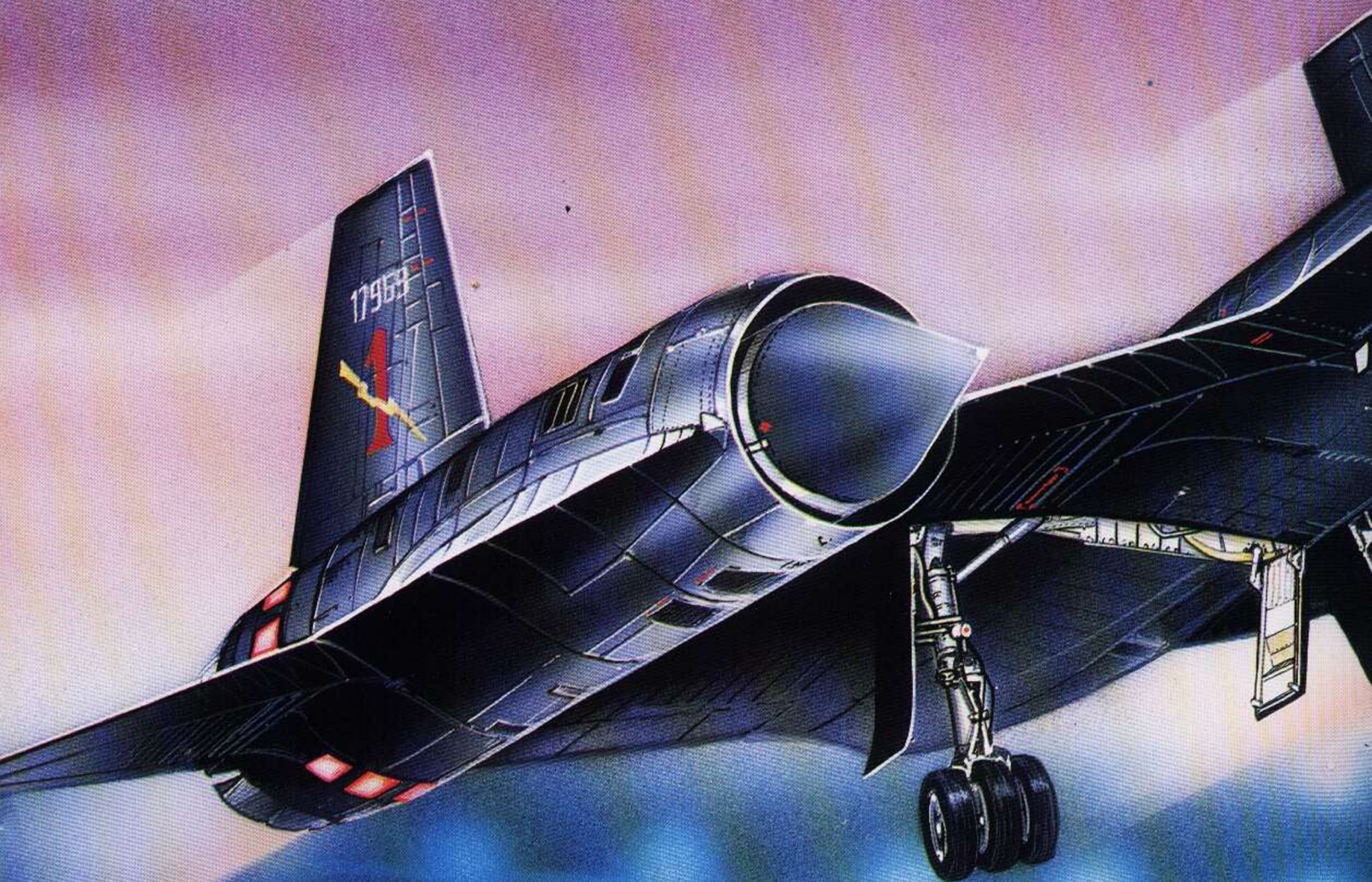

*modelki*  
**Fly Model**

**Nr 31**

ISSN 1233 - 9423  
WYDANIE II

**MODEL  
KARTONOWY  
1:33**







52aP

53aP

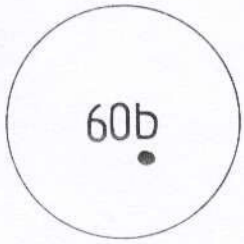

60b

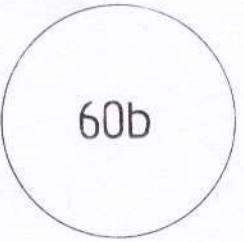

60b

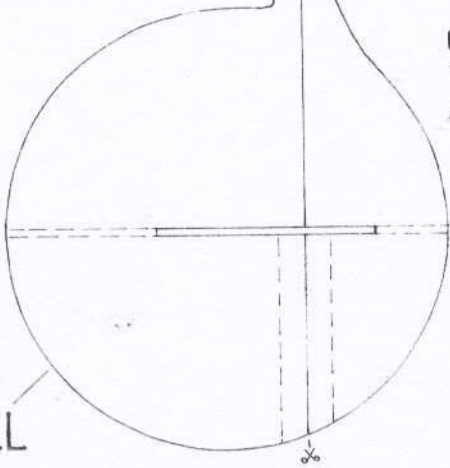

52aL

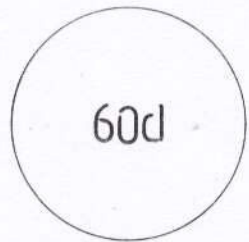

60d

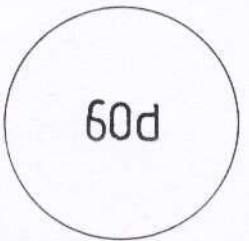

60d

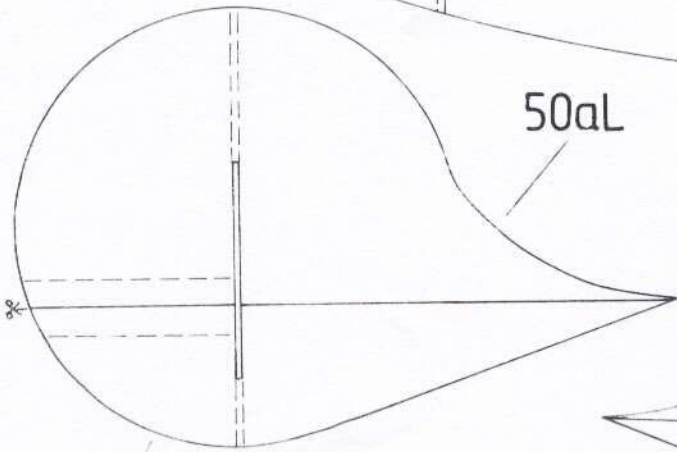

51aL

50aL

50aP

53aL

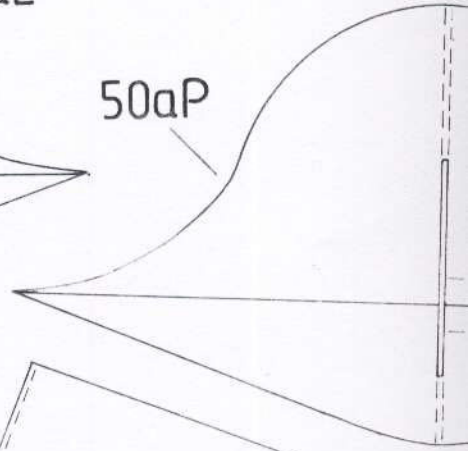
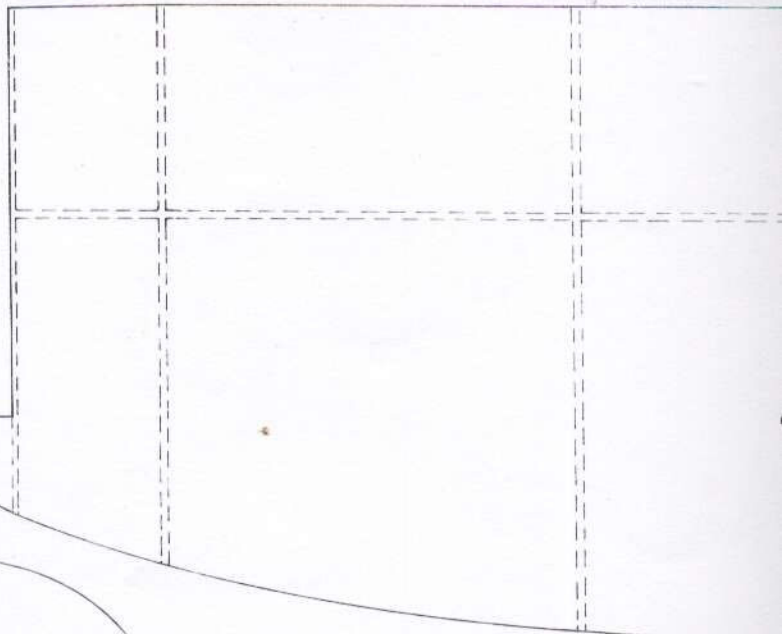
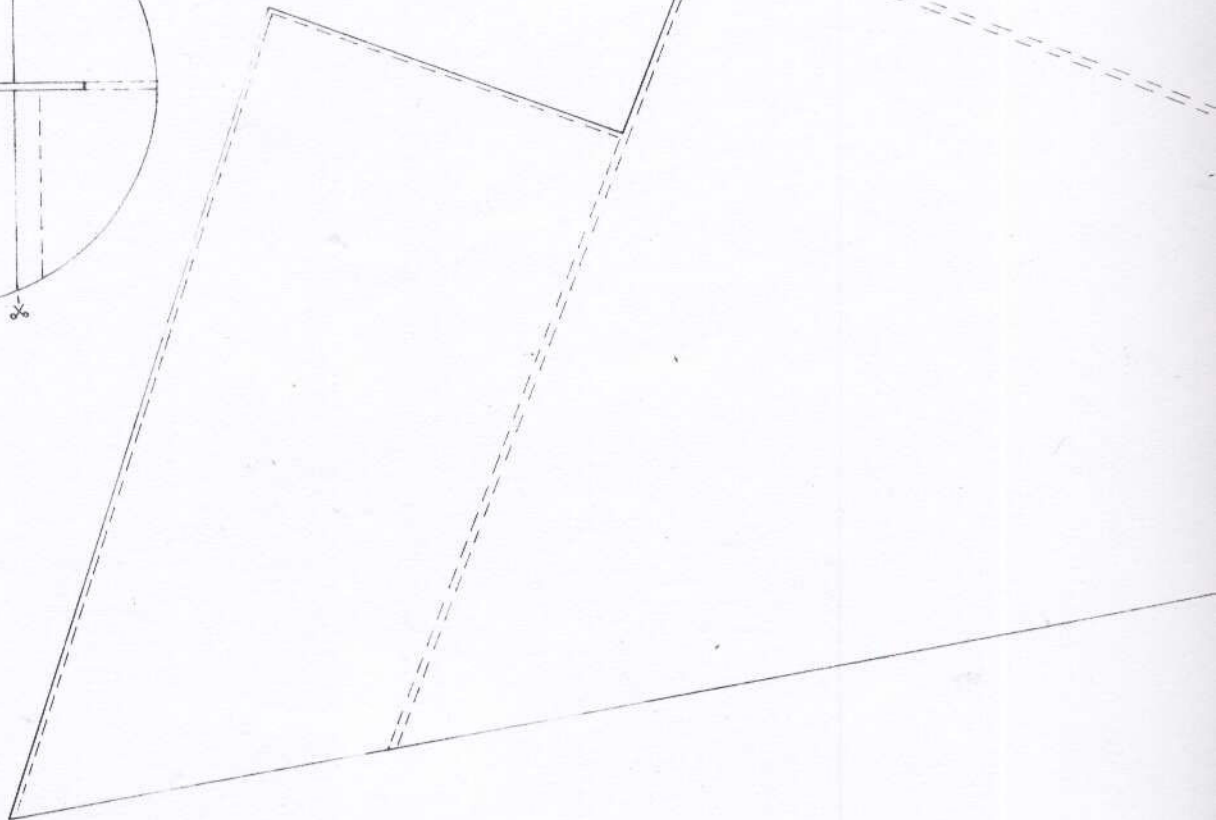

43L

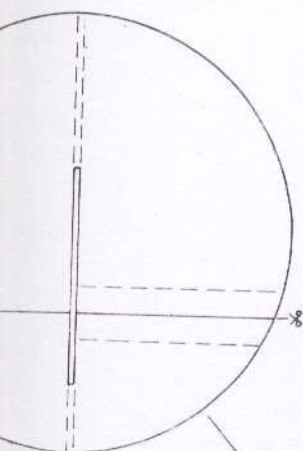

51aP

60a

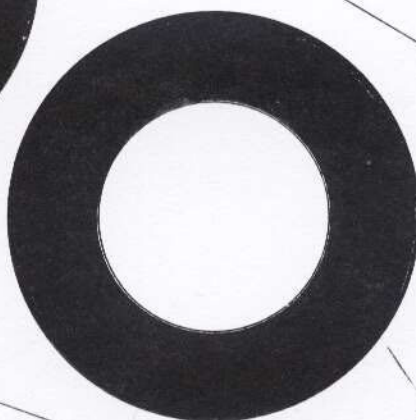
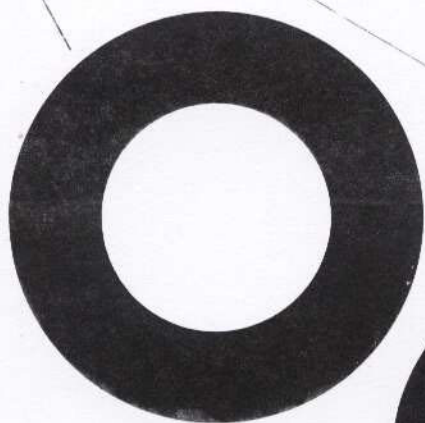

60a

43P

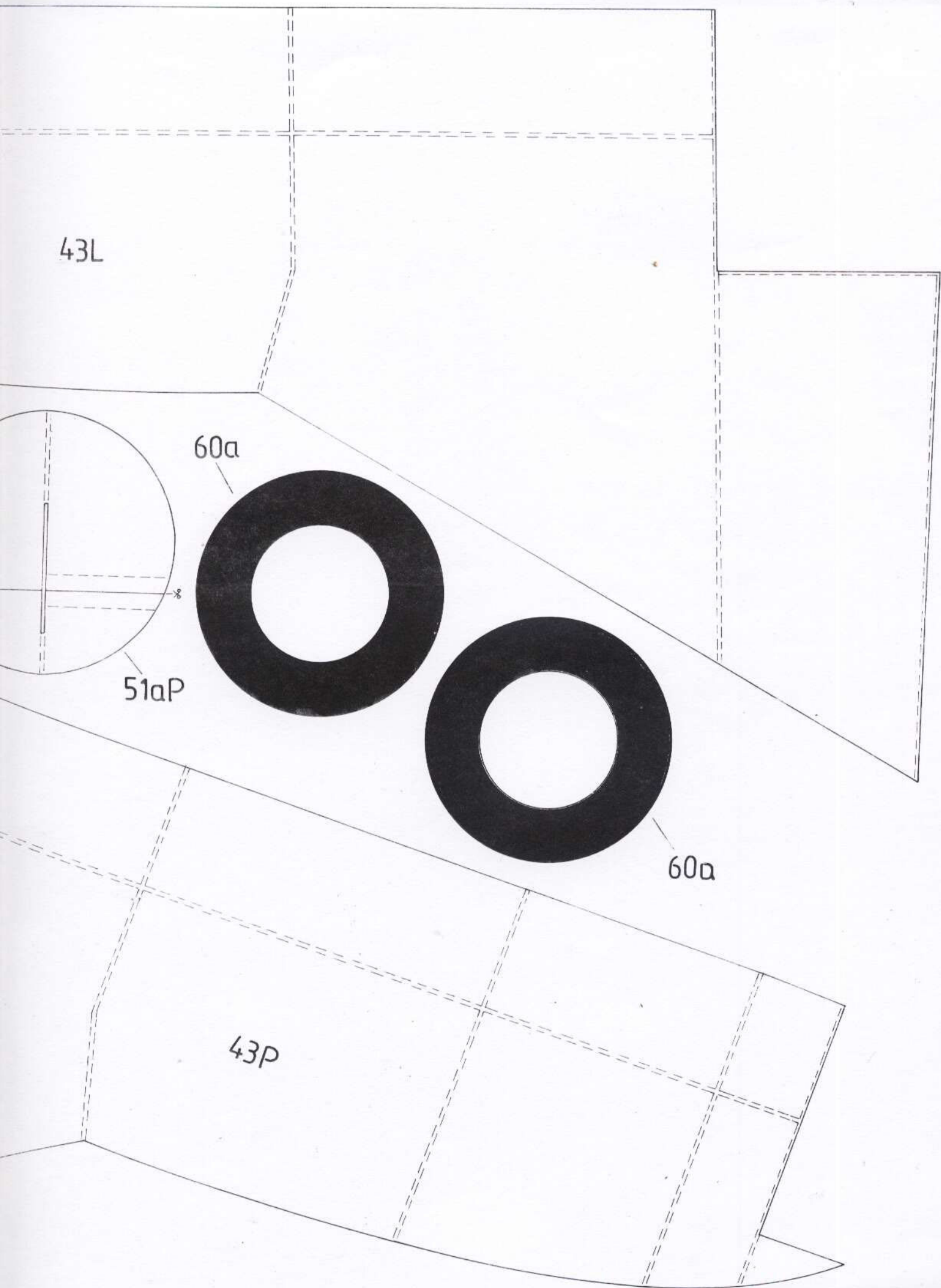



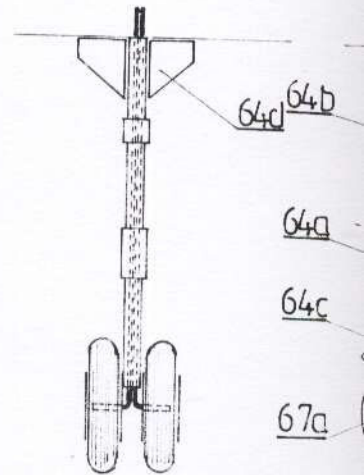
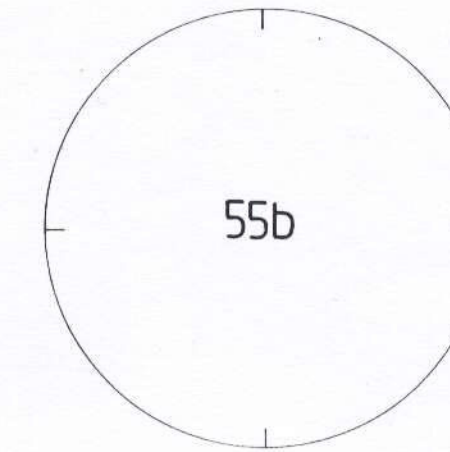
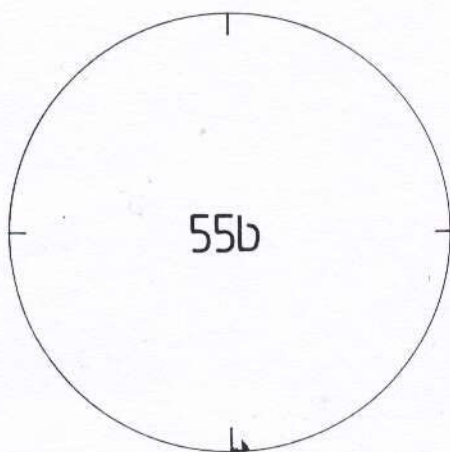
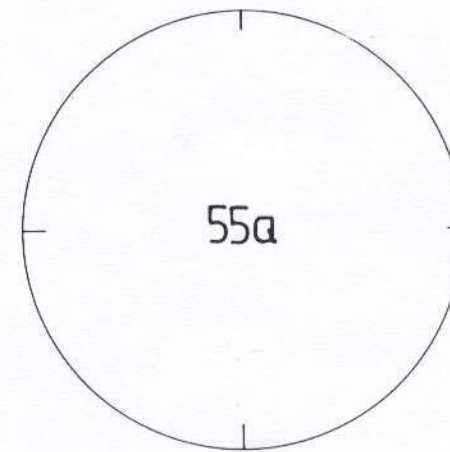
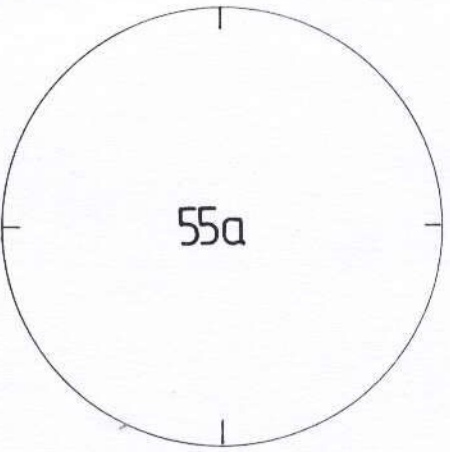
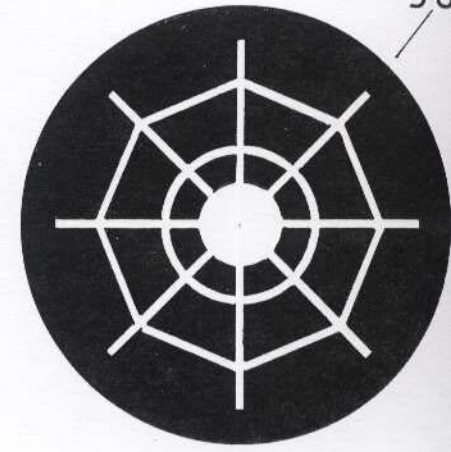
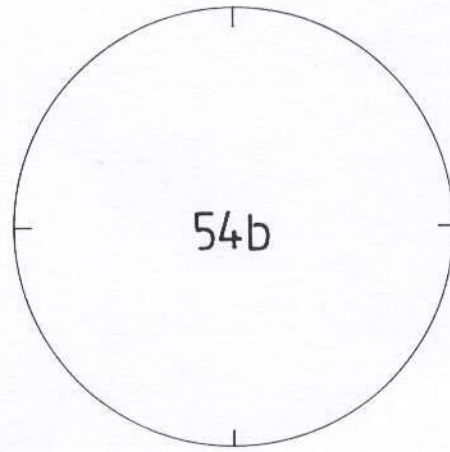
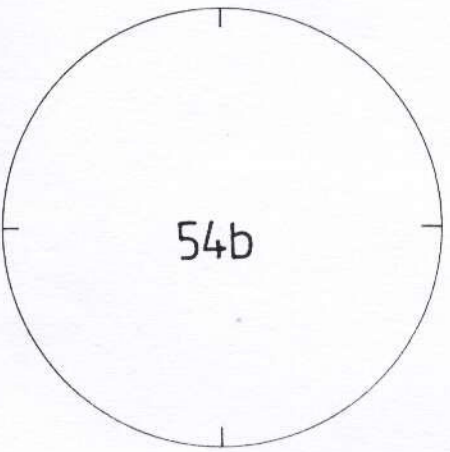
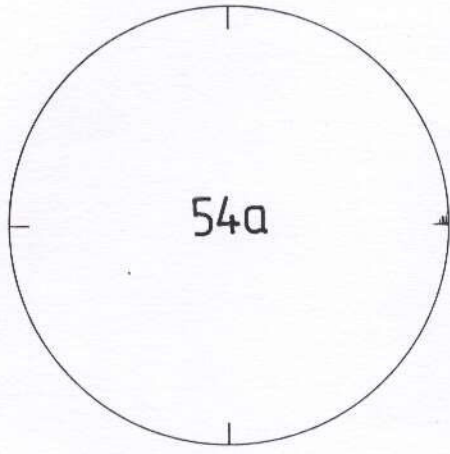
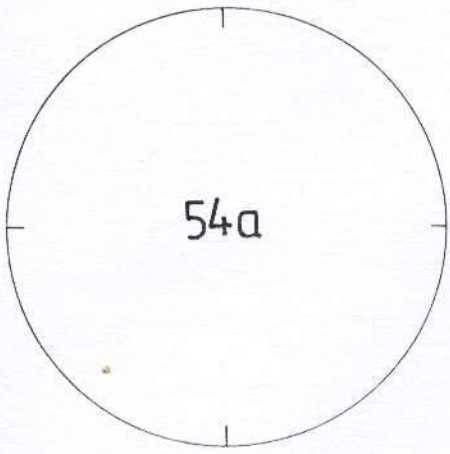



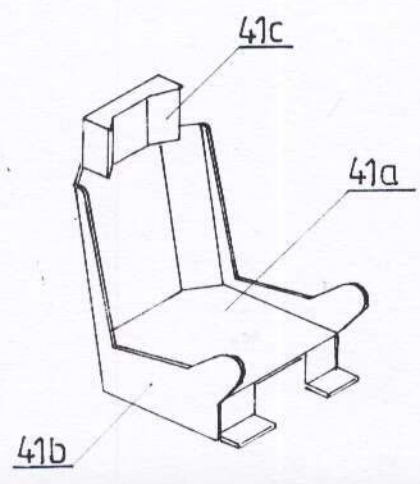
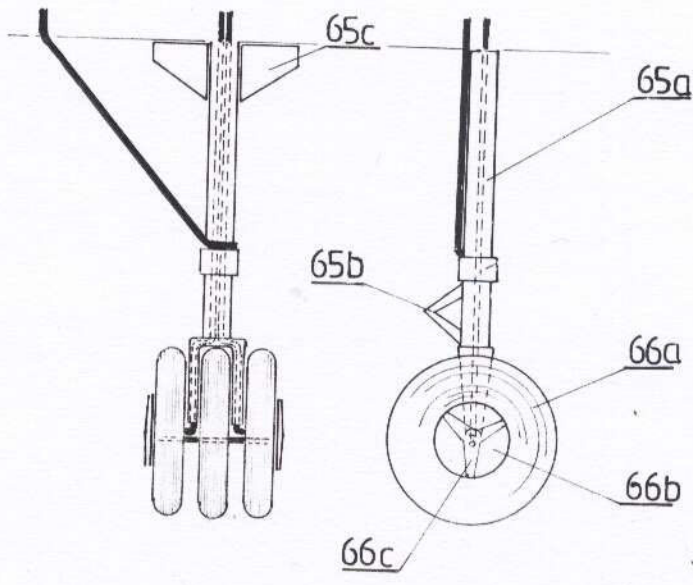
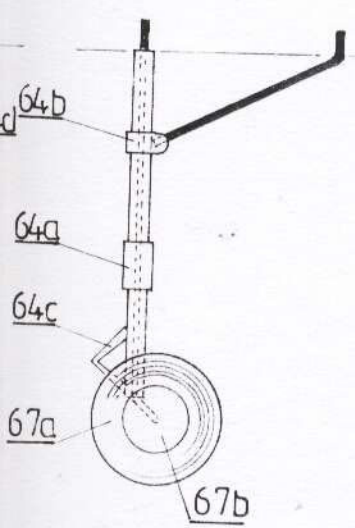
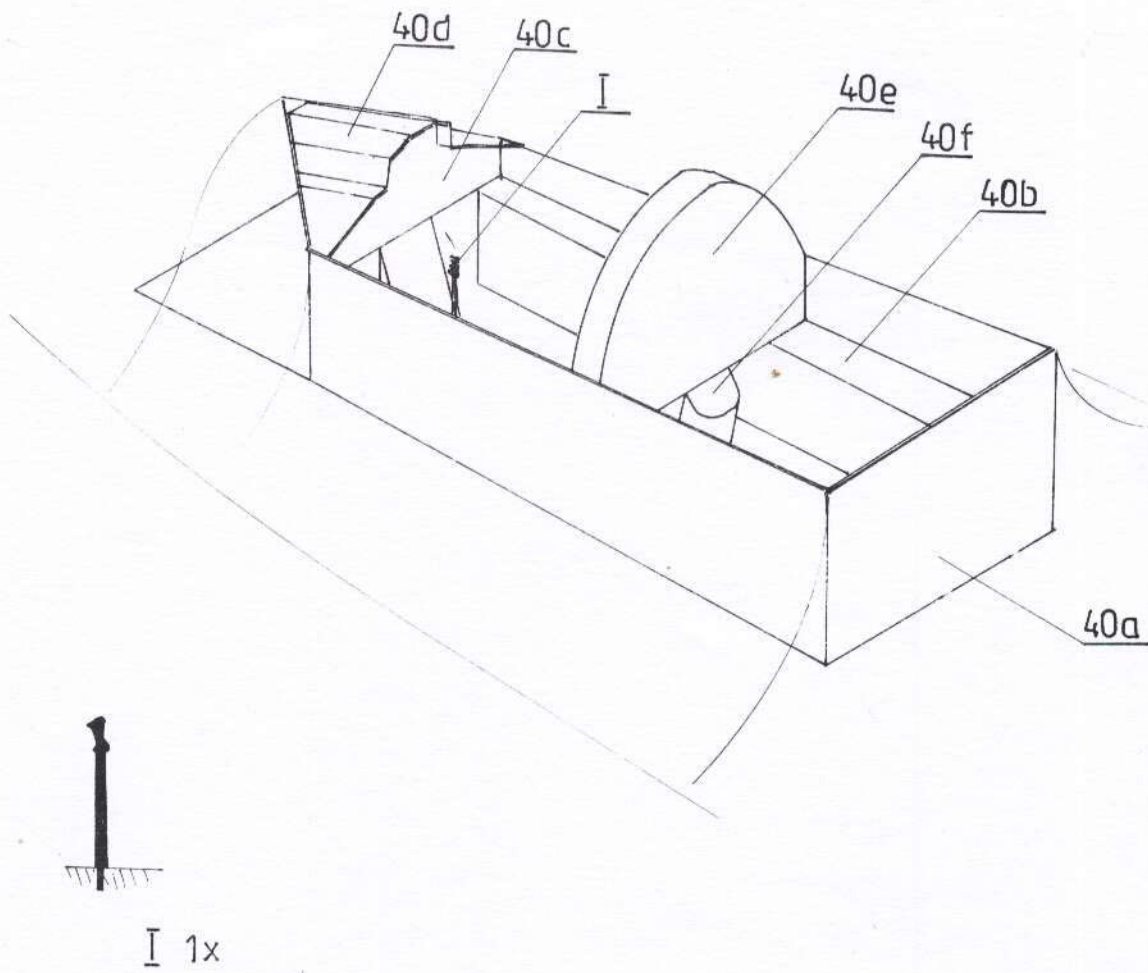
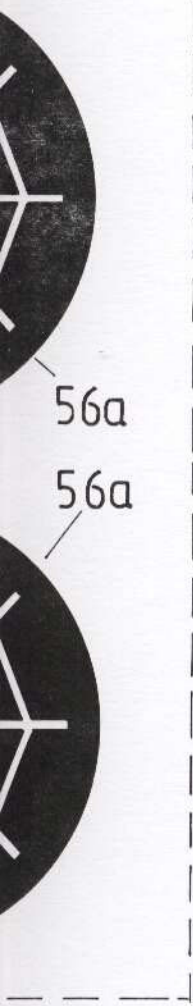



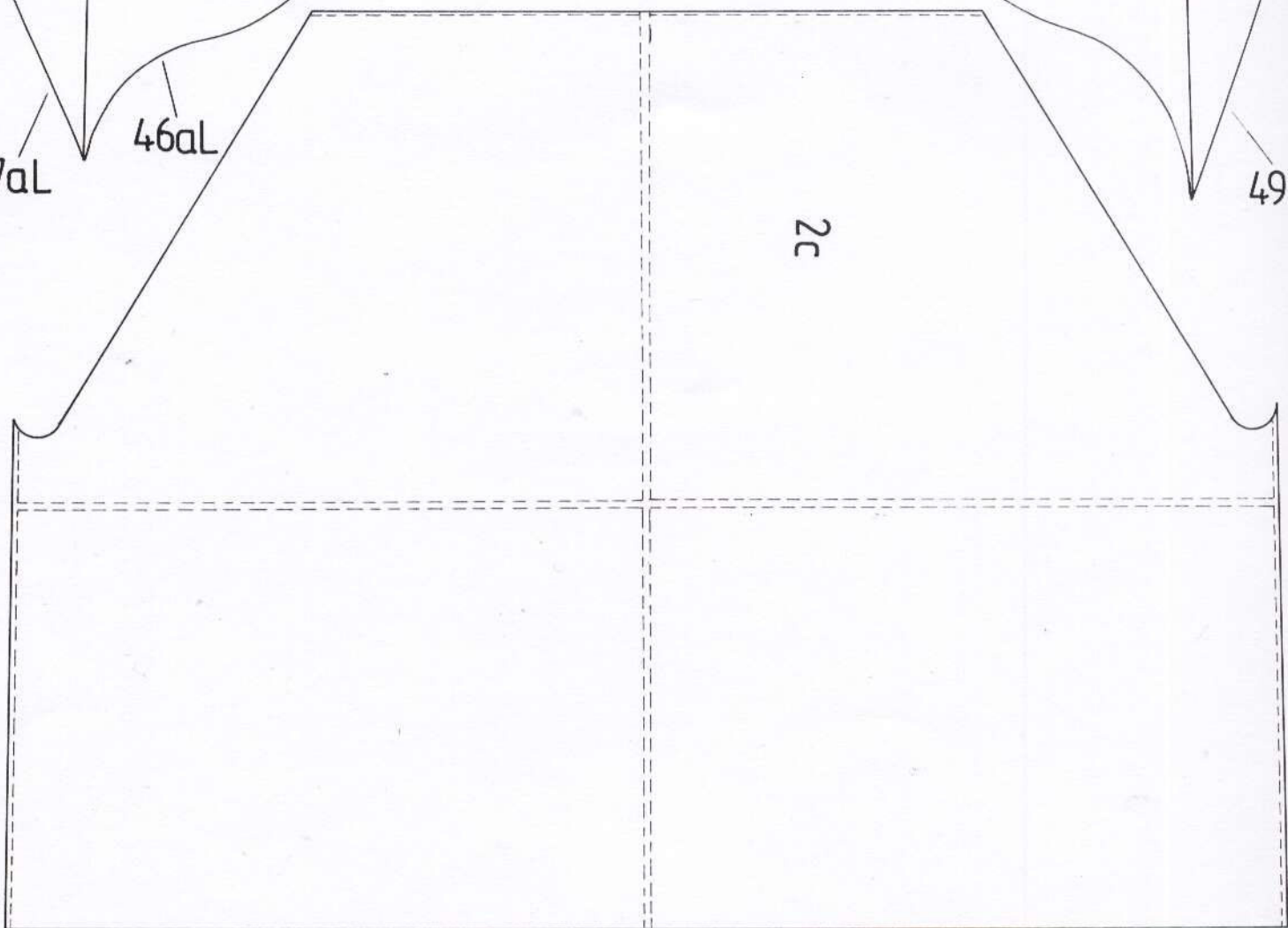
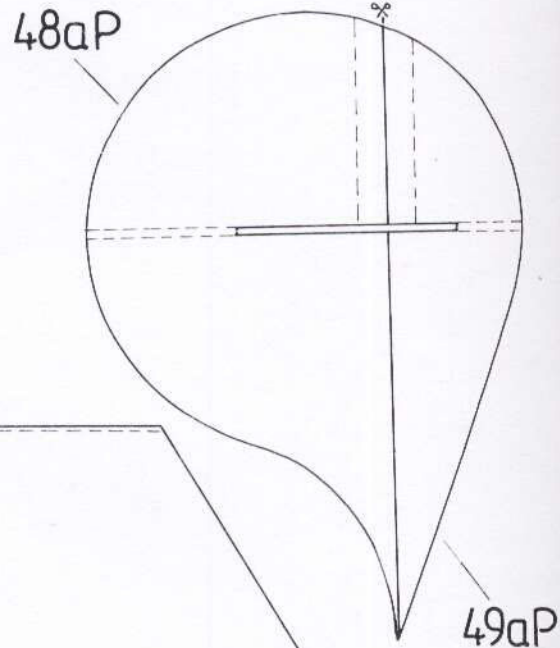
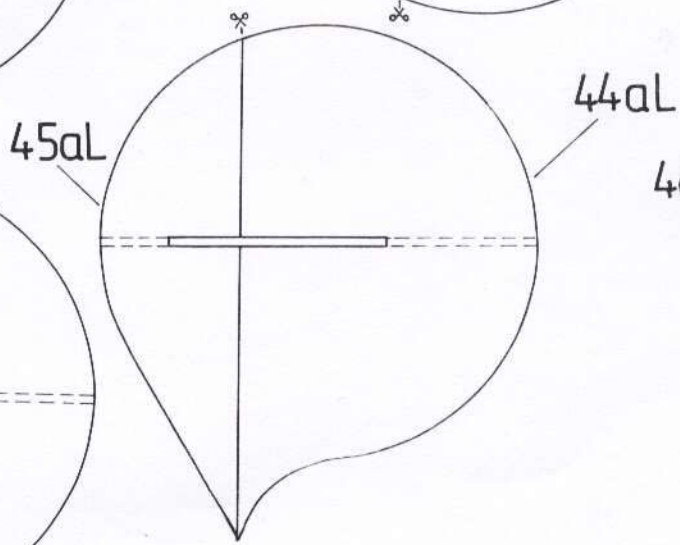
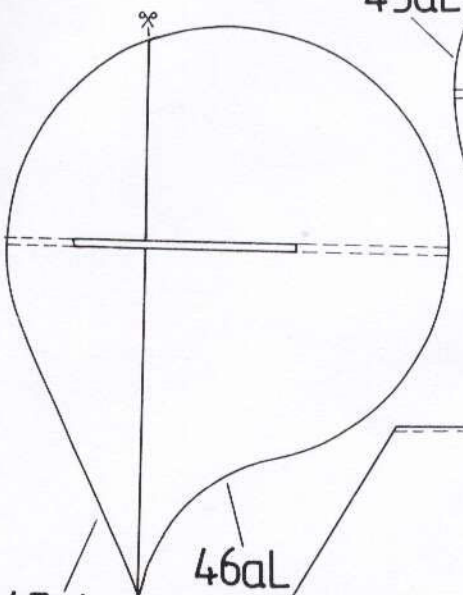
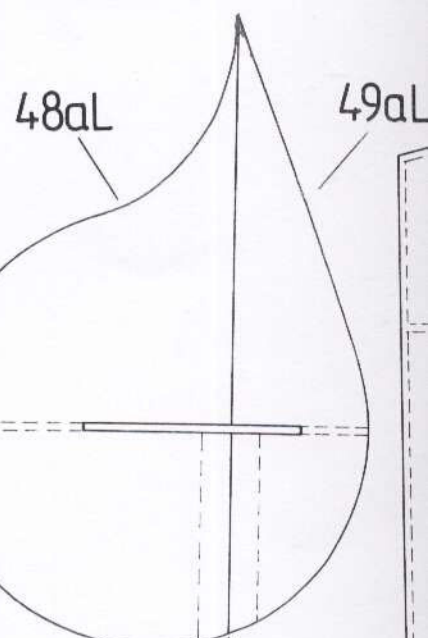
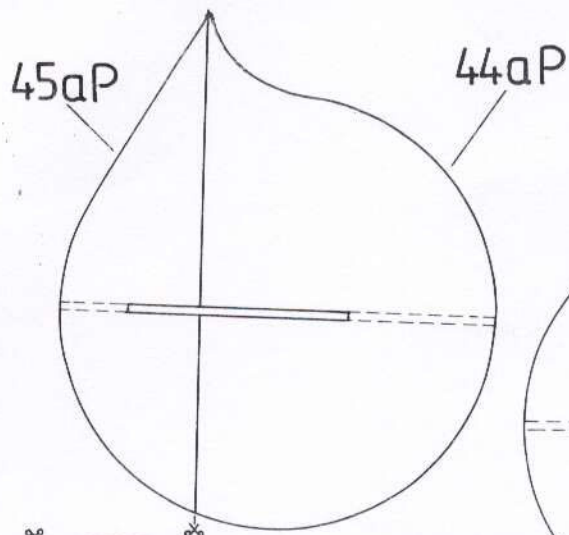
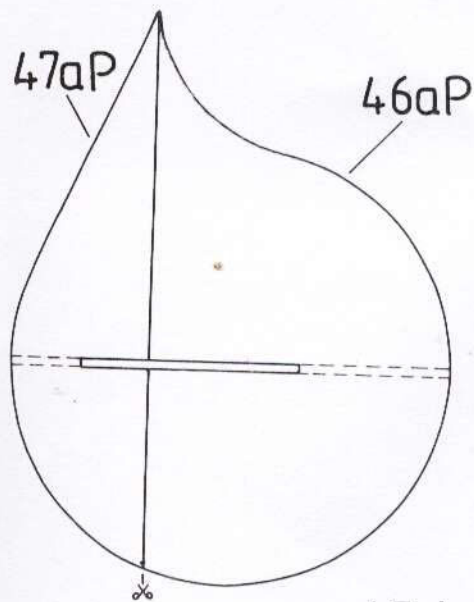



49aL

49aP

2d

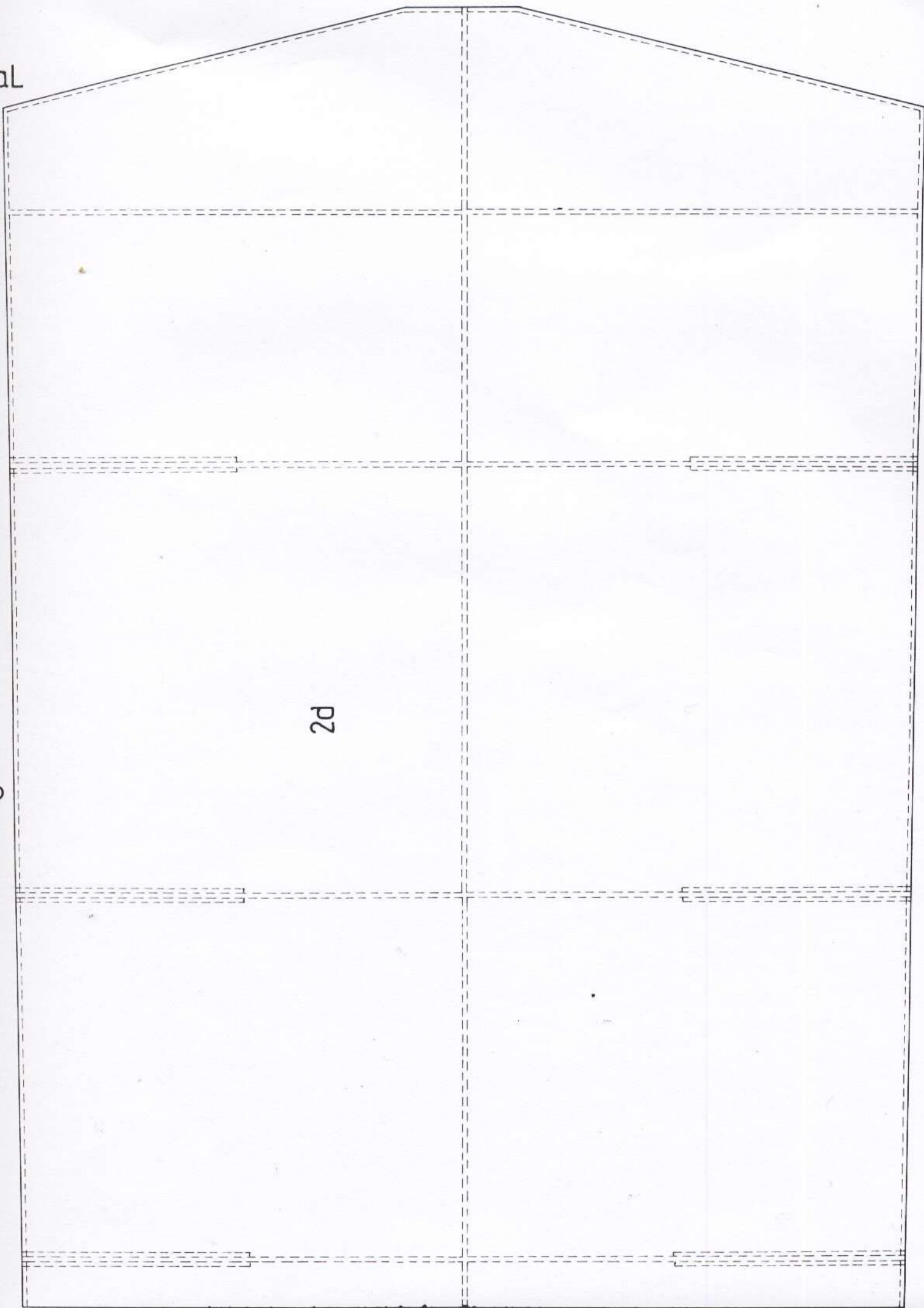



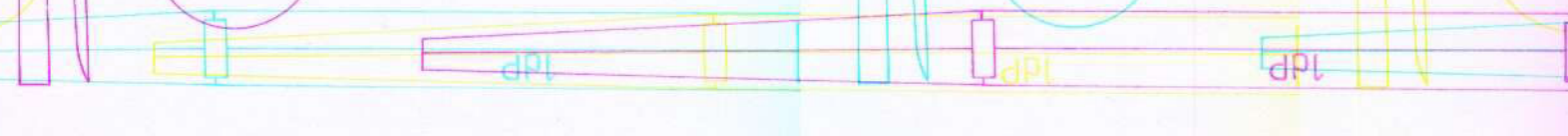
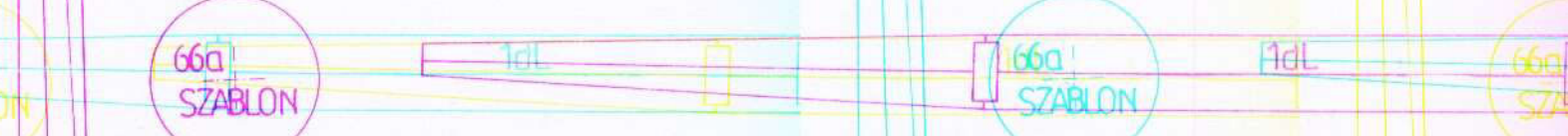
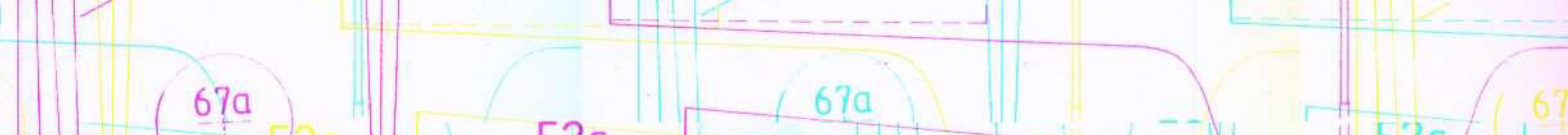
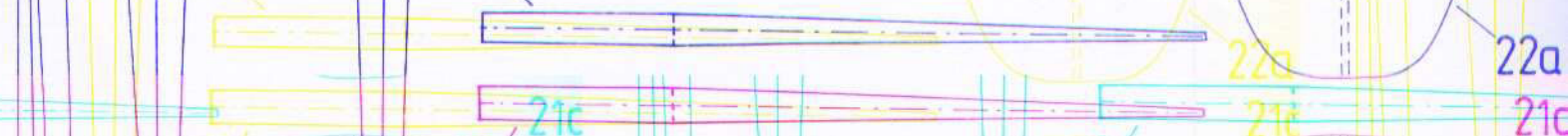
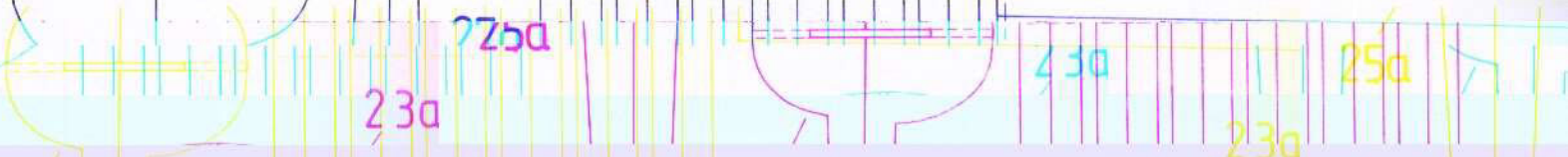
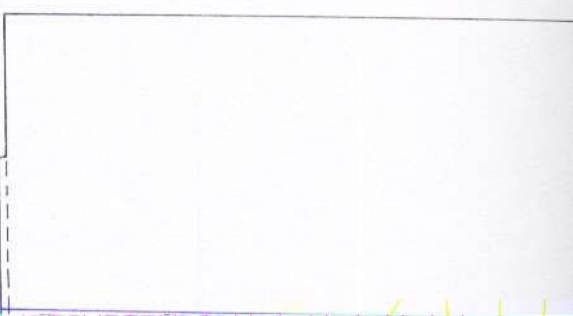
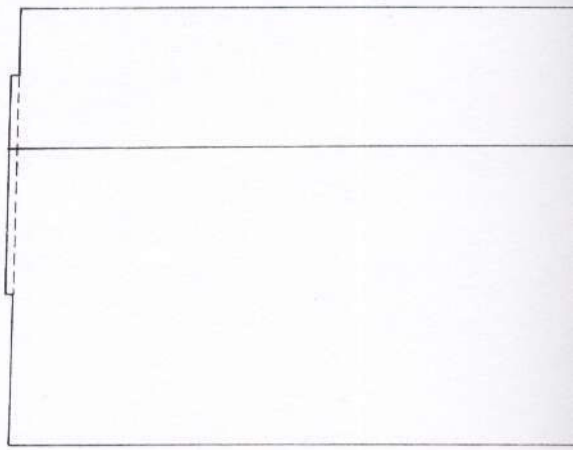
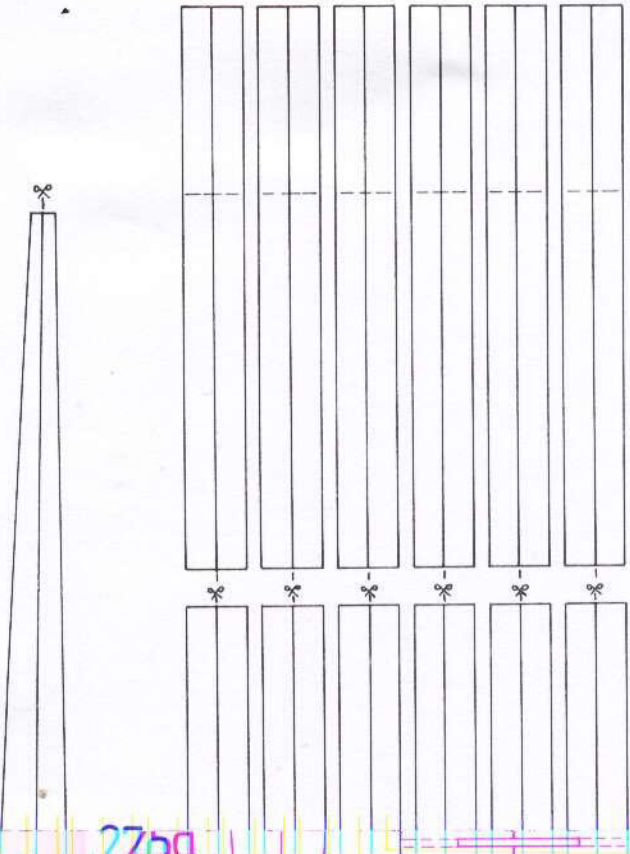
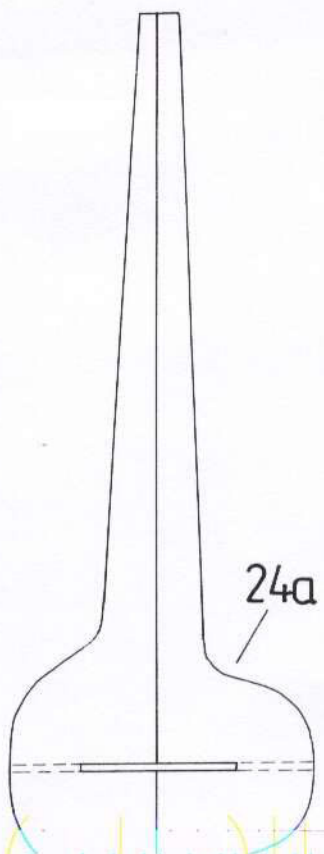



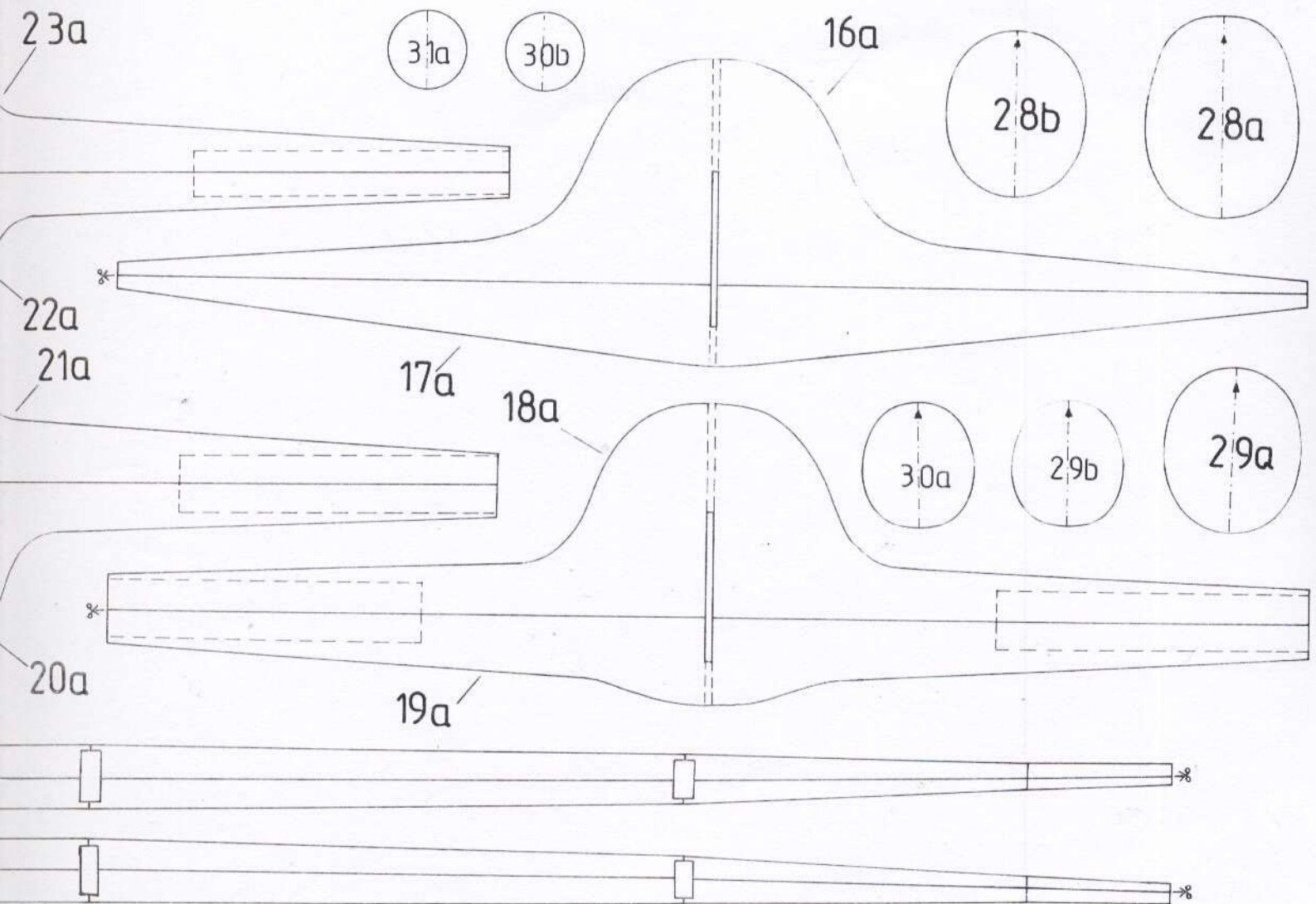
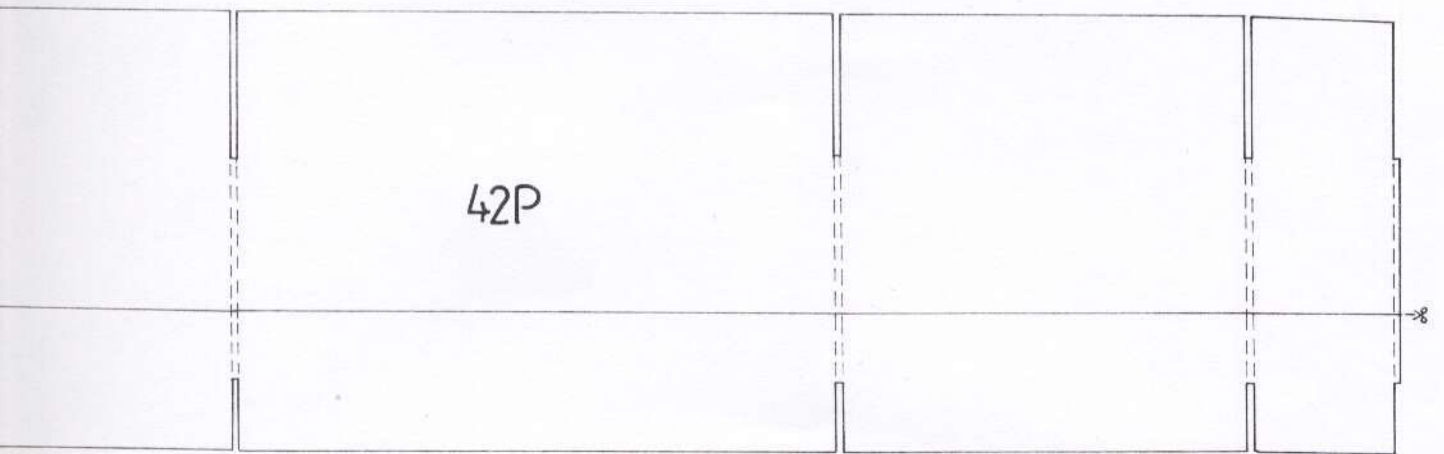
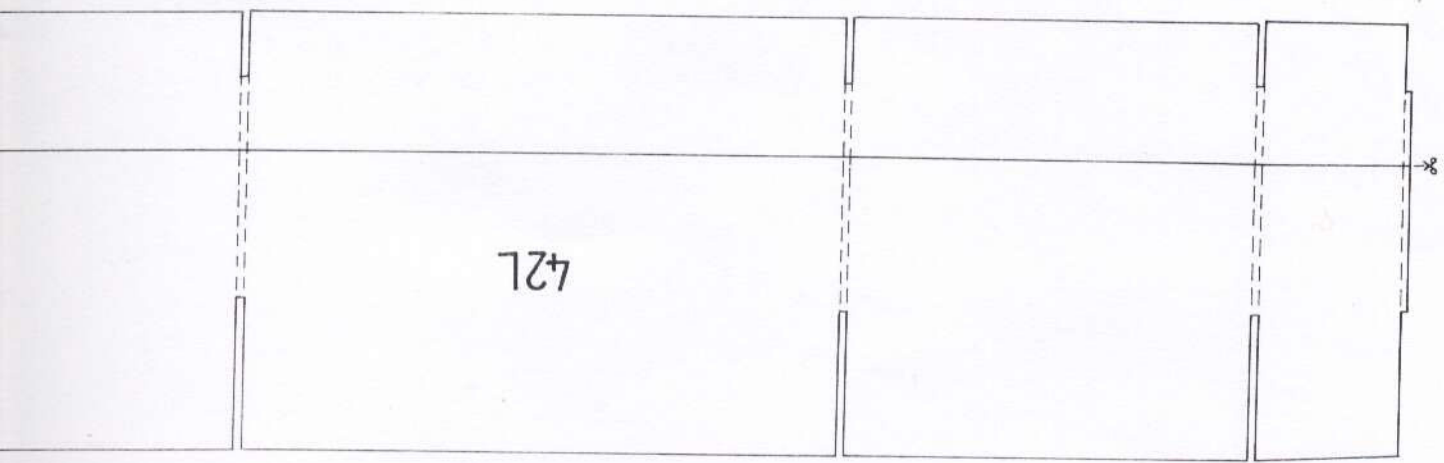



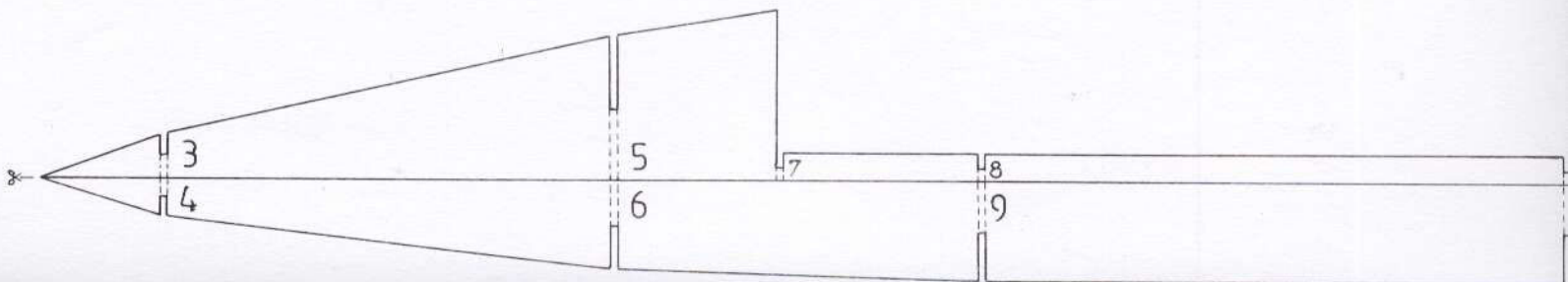
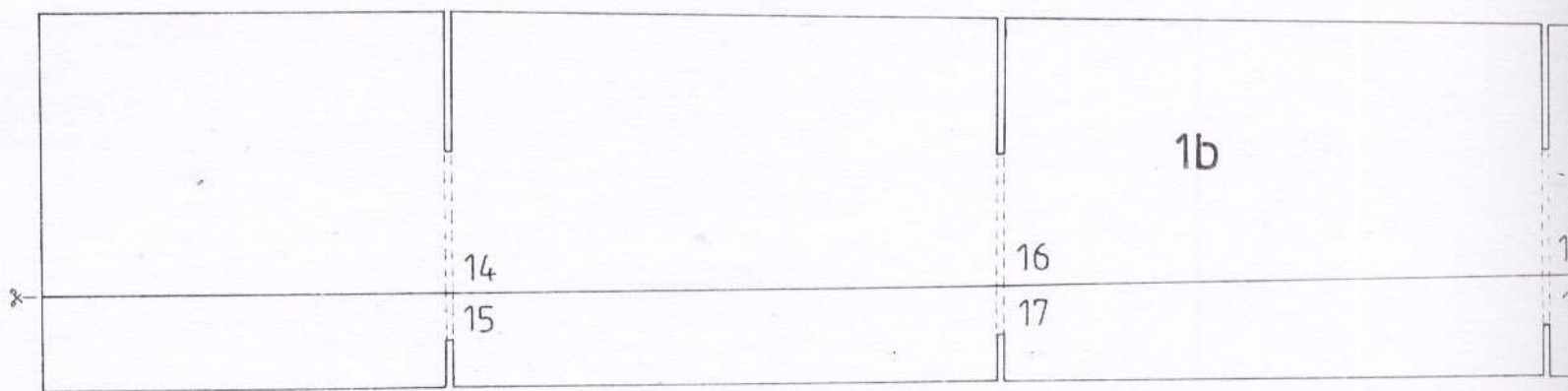
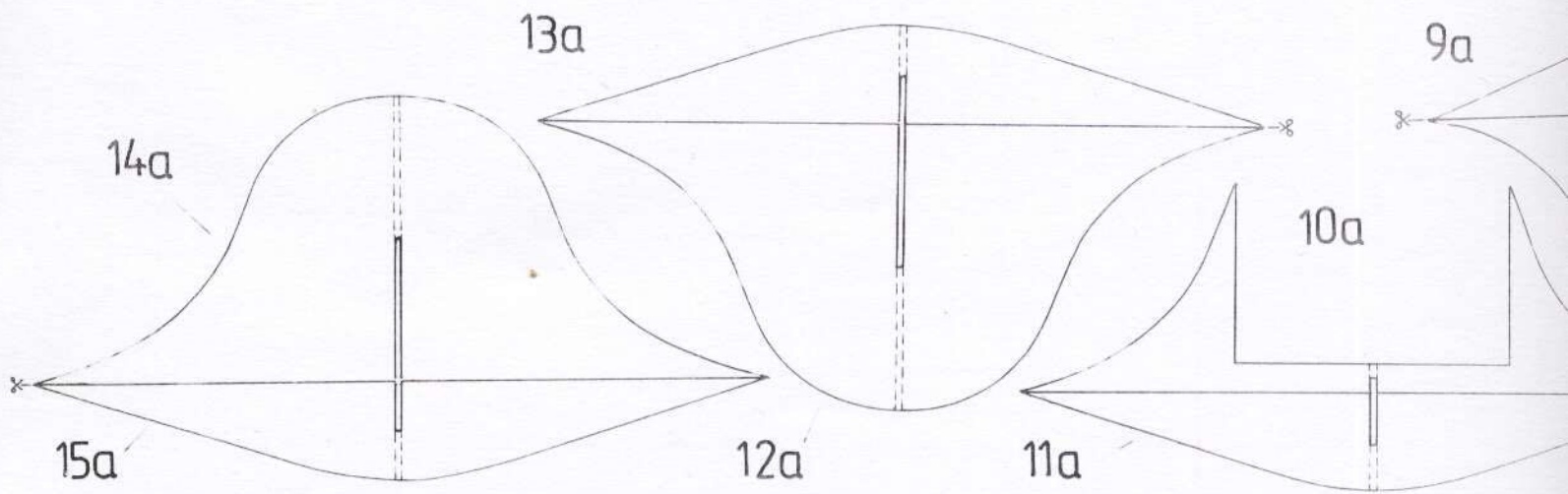
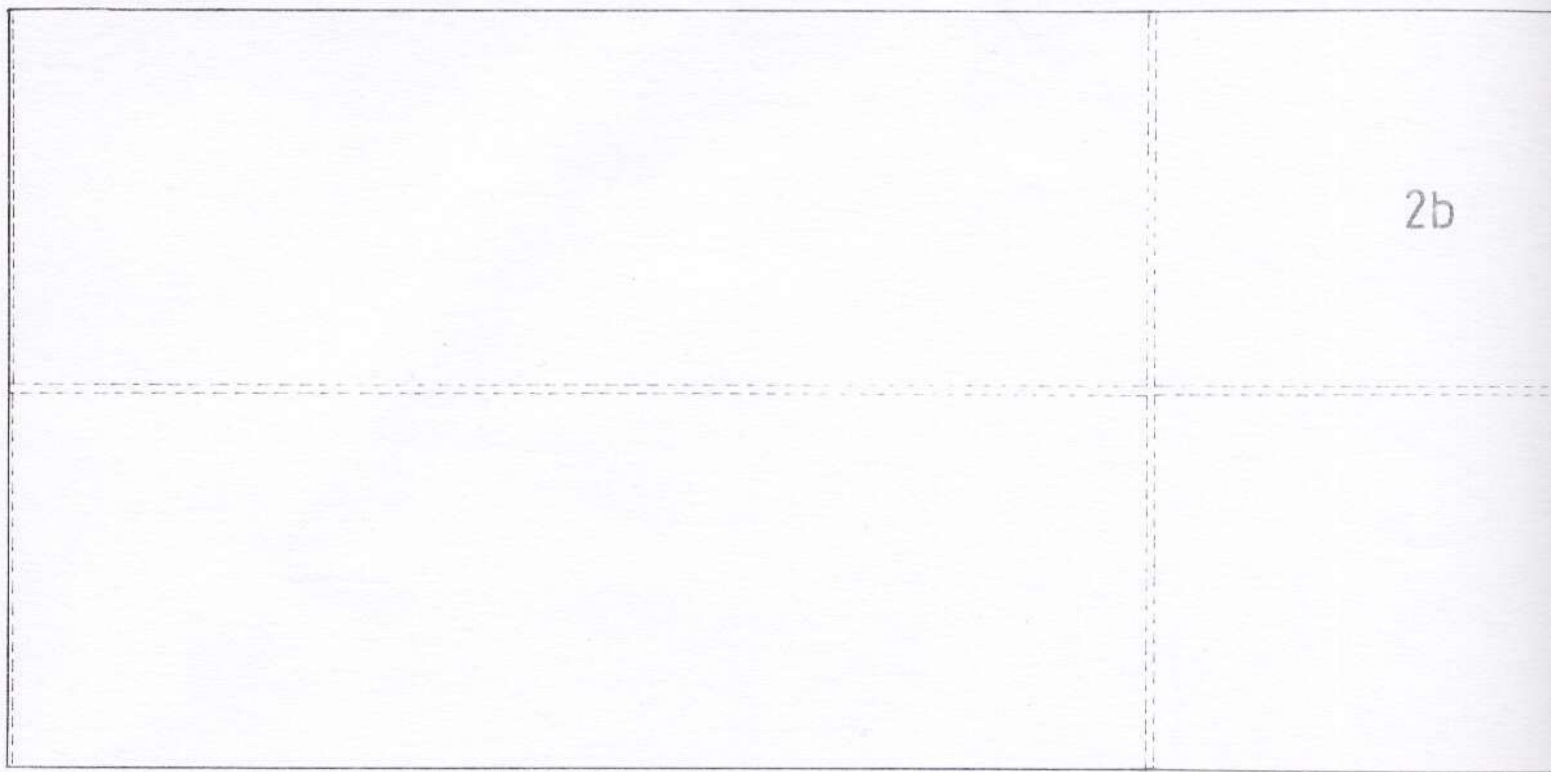



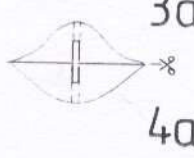
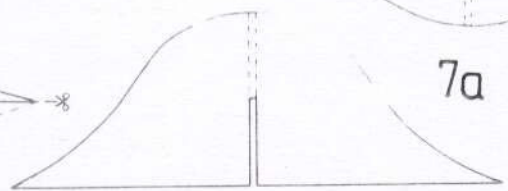
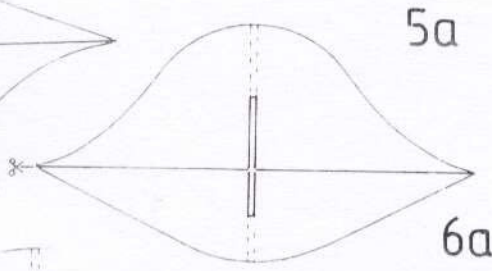
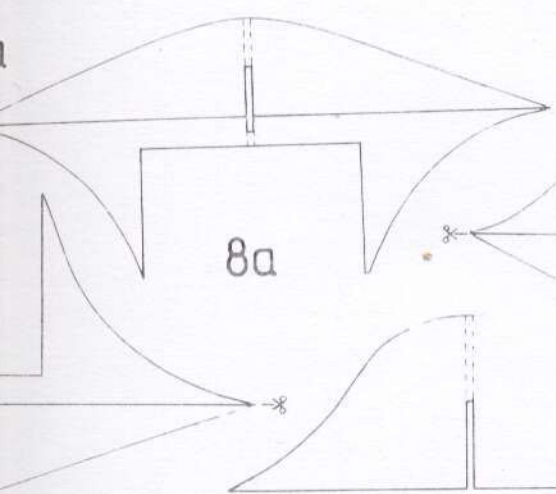
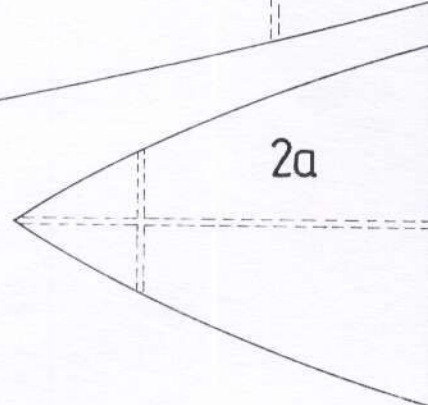
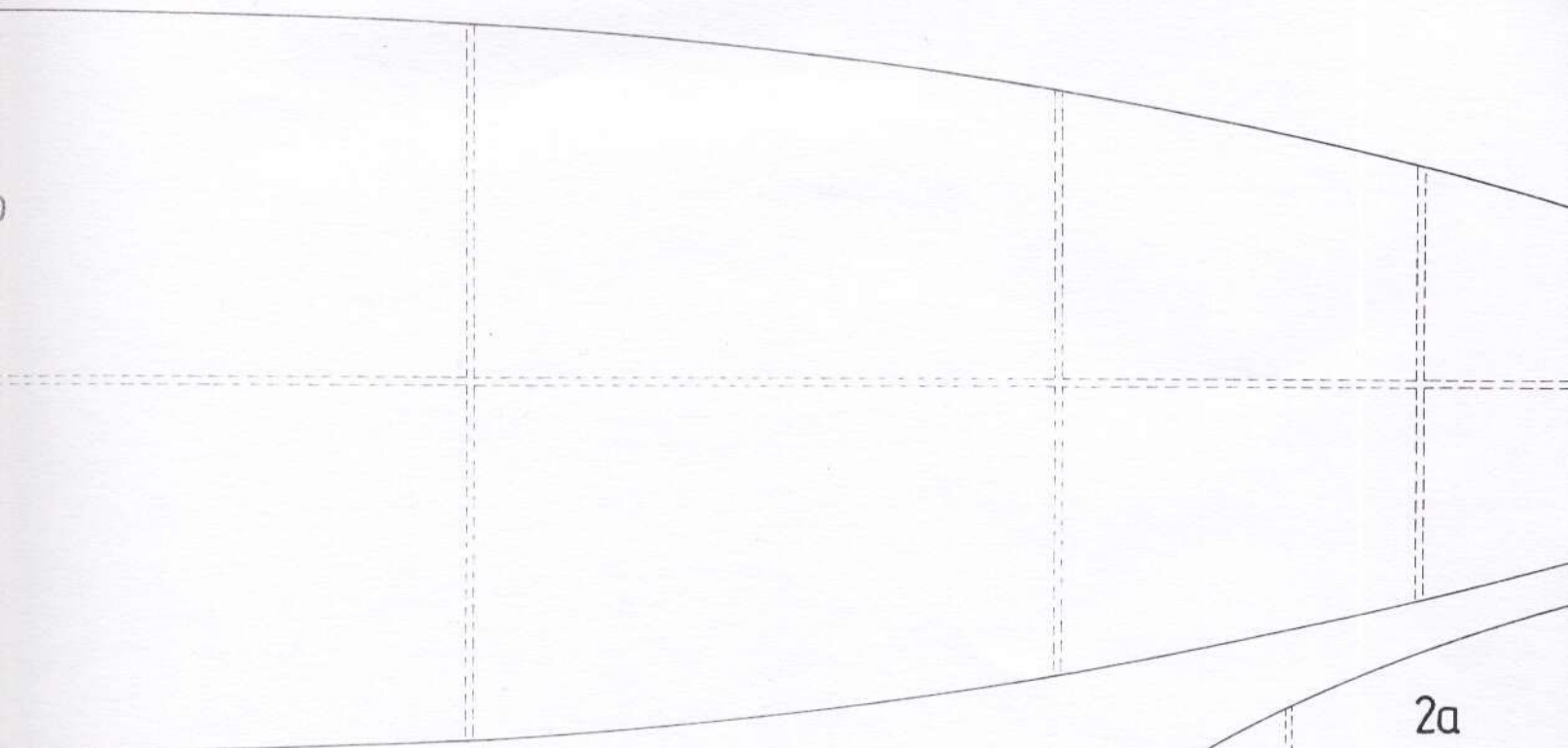

6a  
3a  
4a

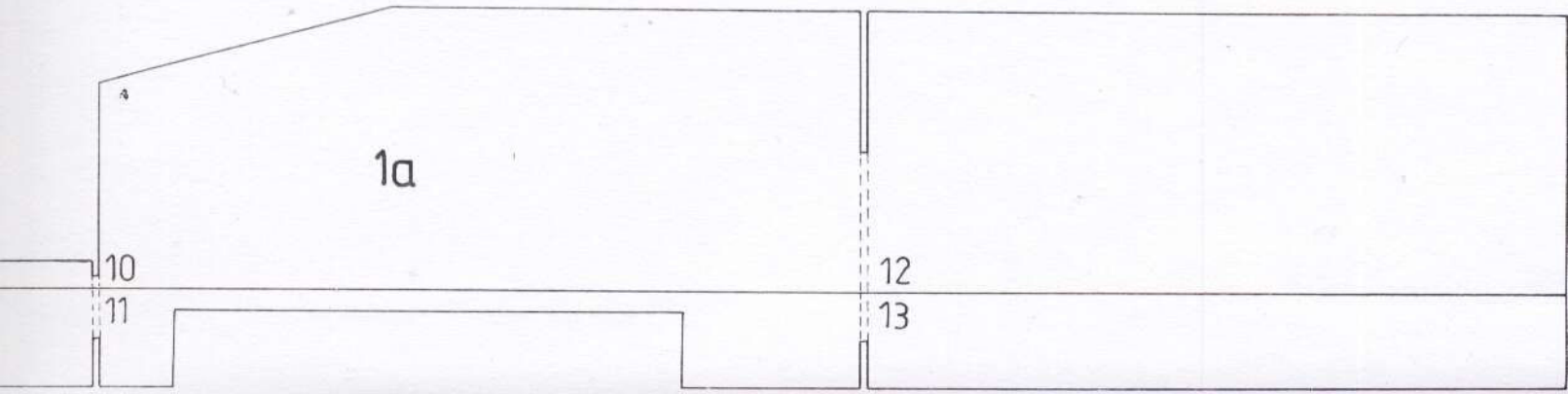
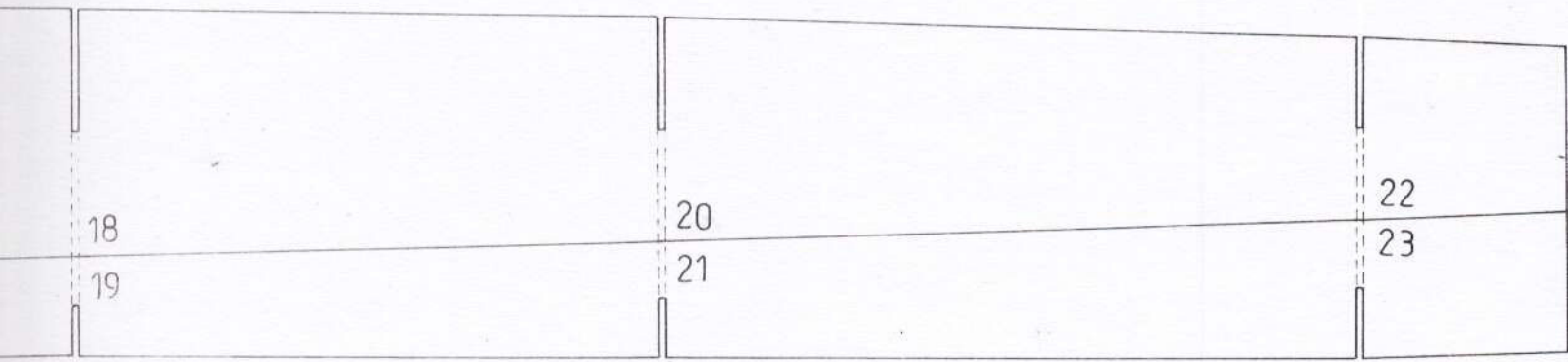
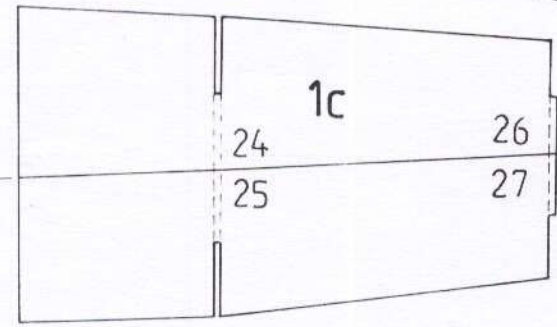



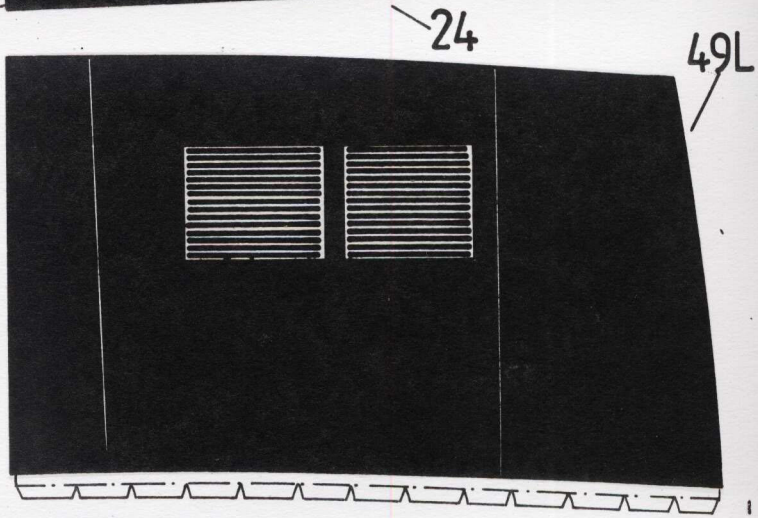
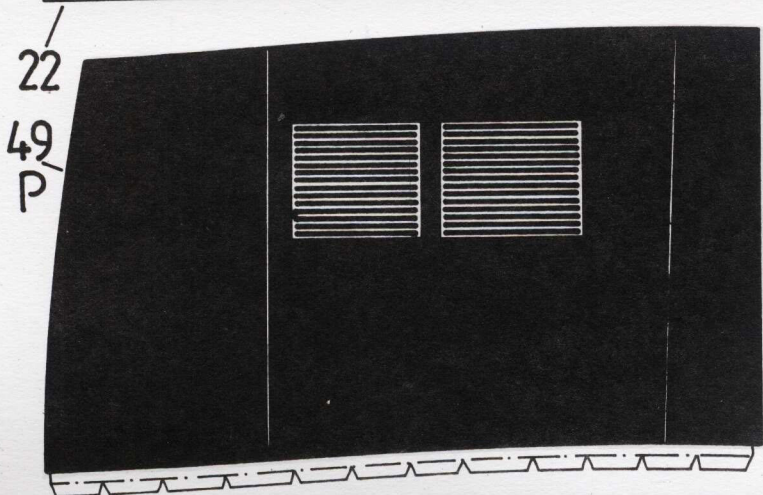
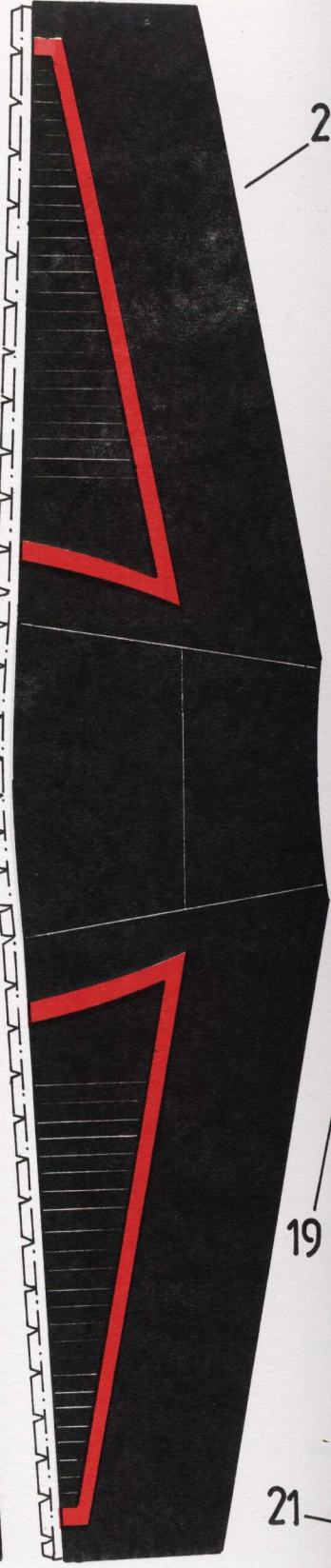
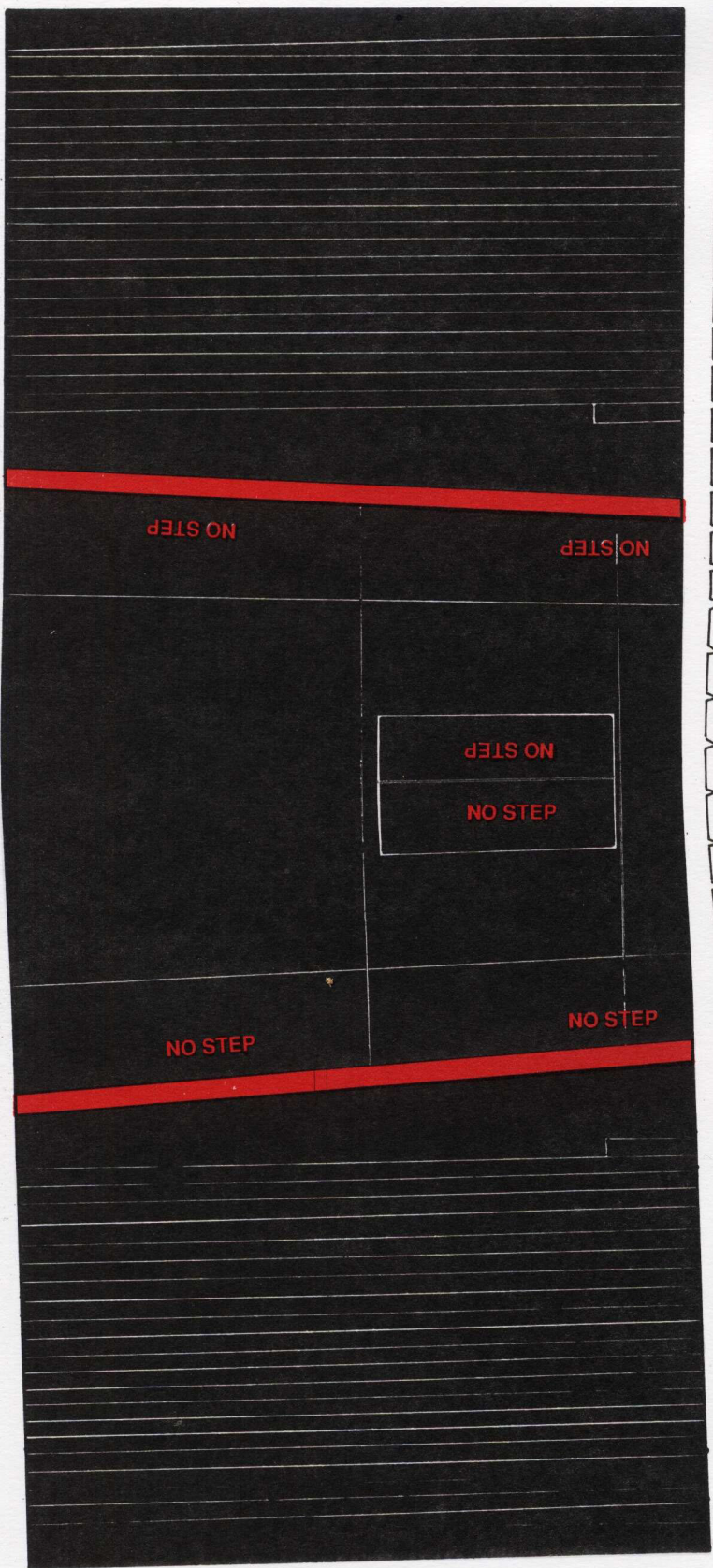



26

17

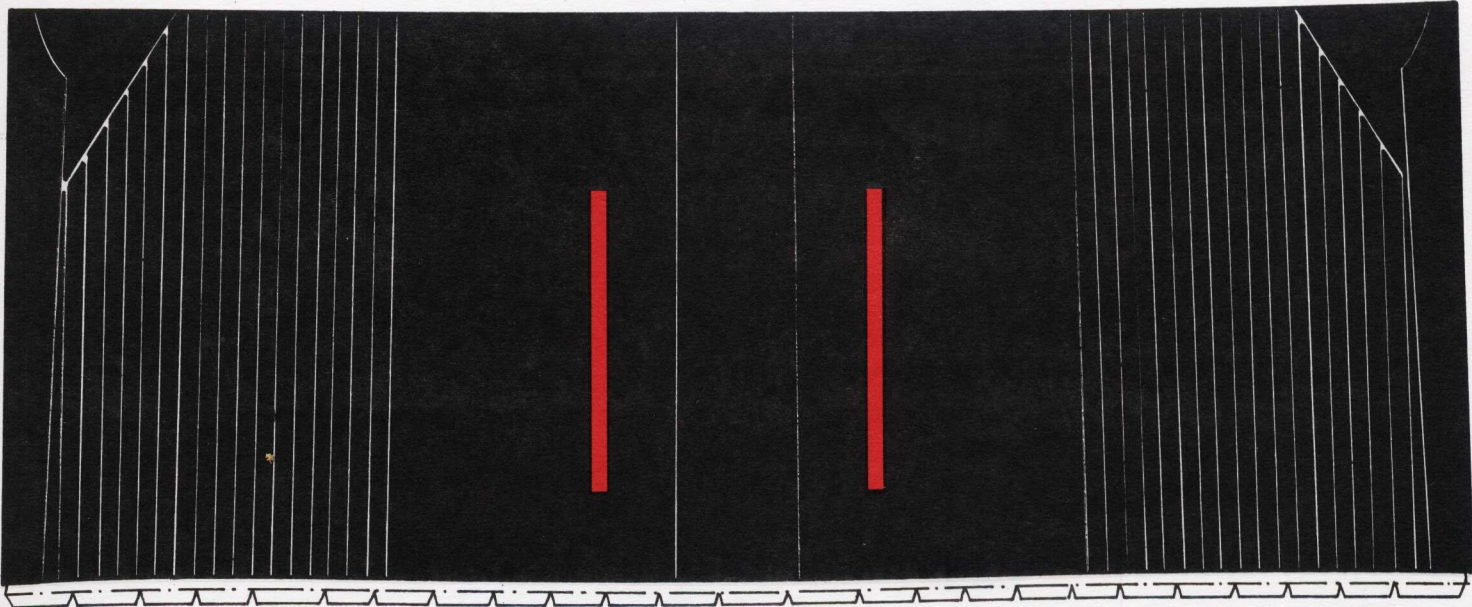
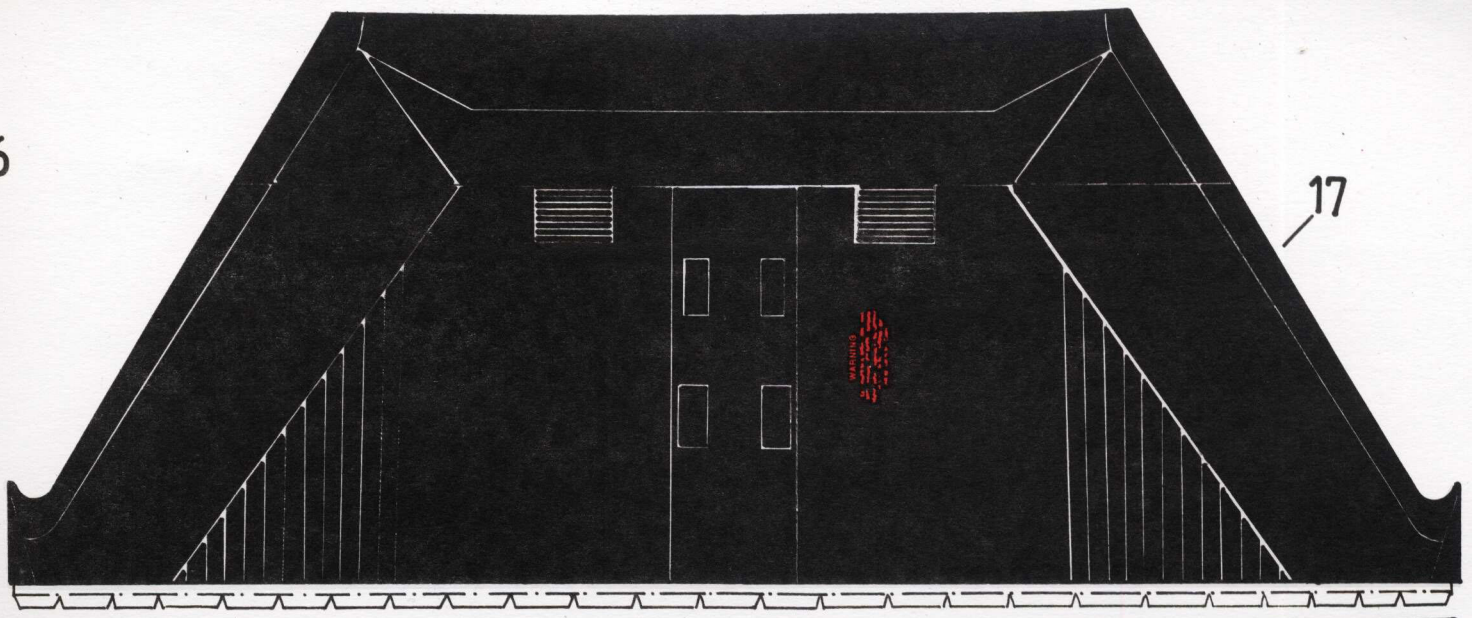

19

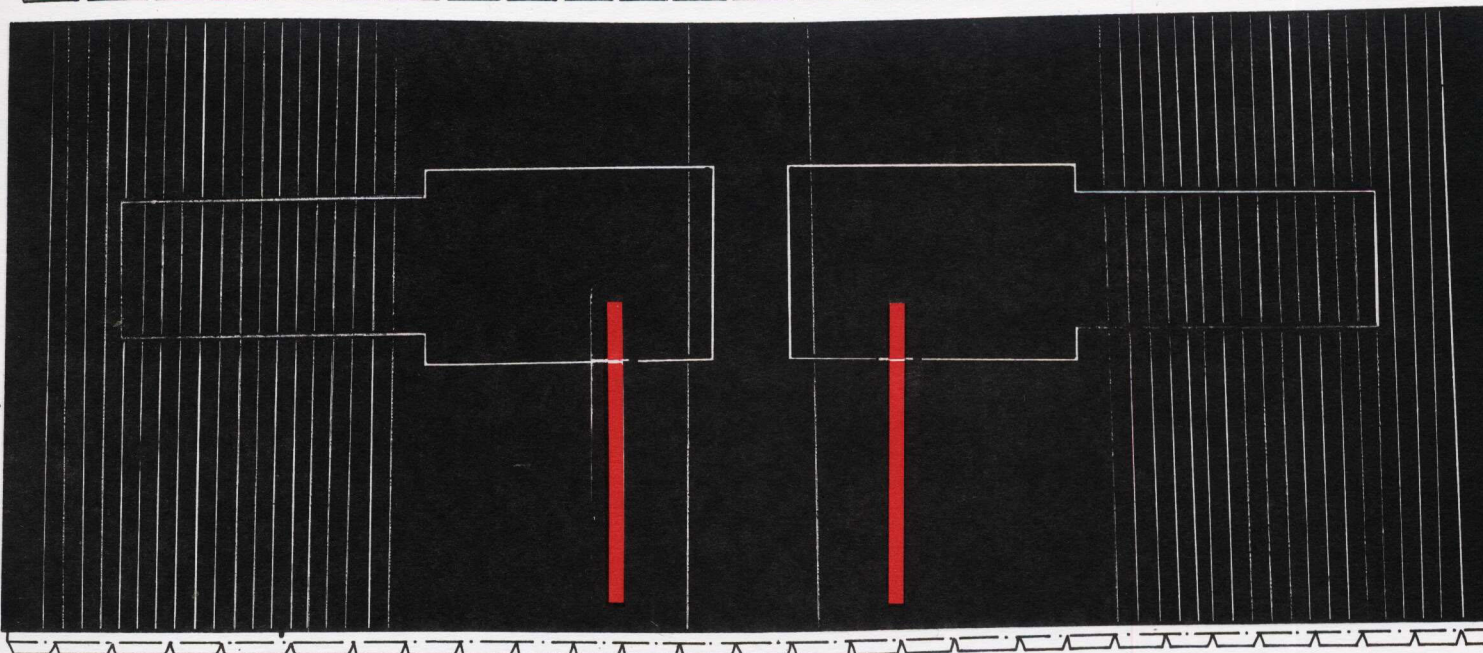

21

49L

55P

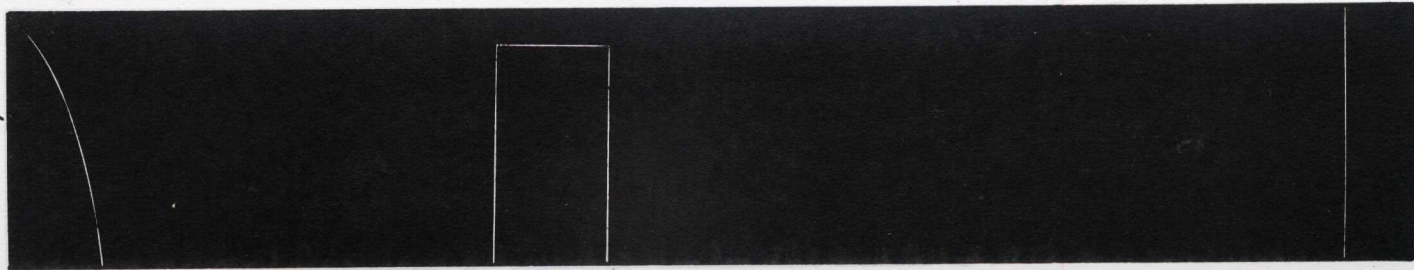





67b

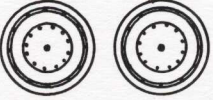
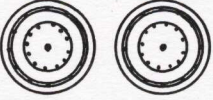
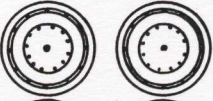
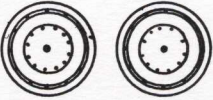

66c

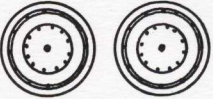

66b

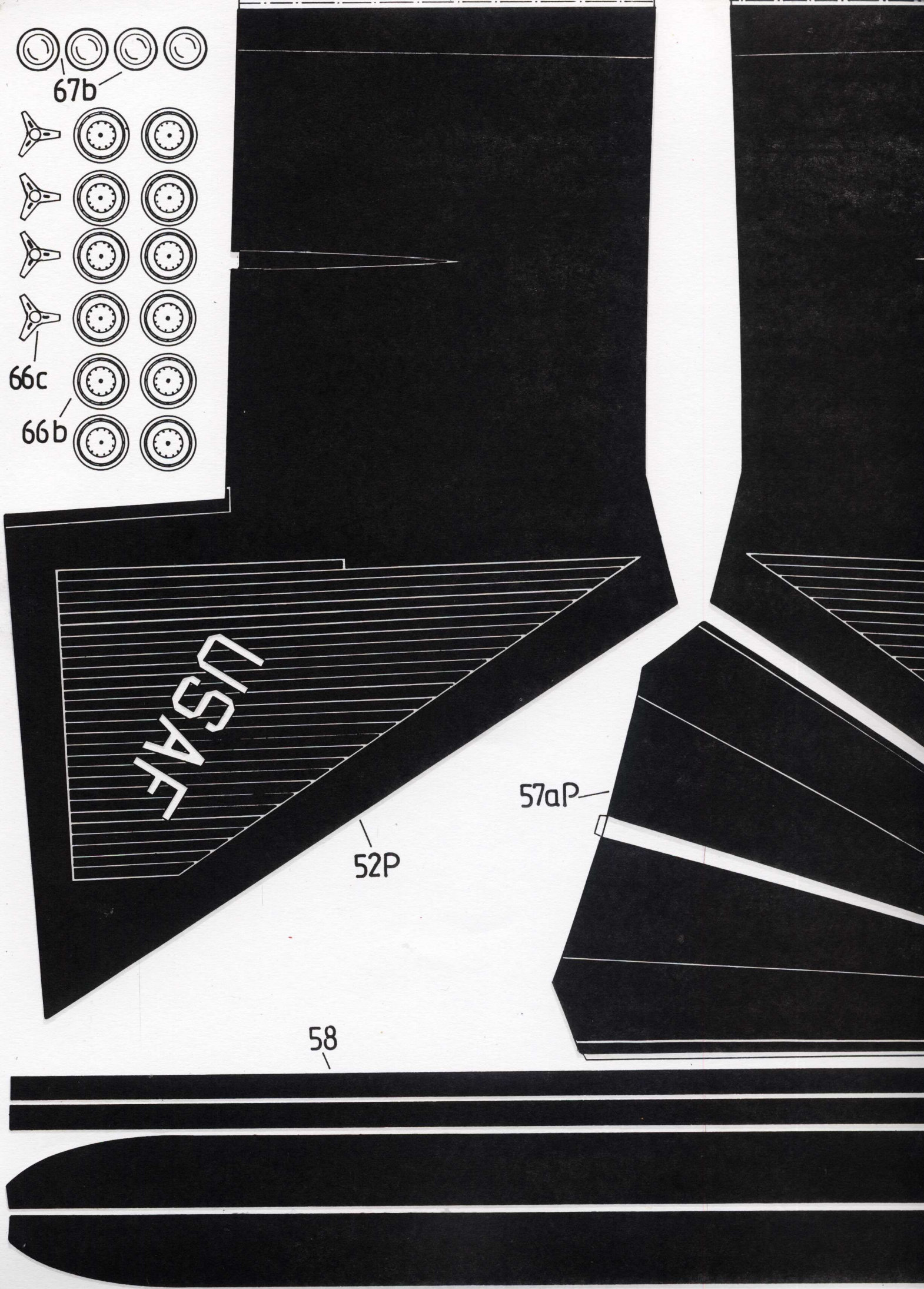
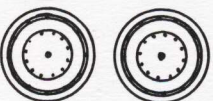

57aP

52P

58



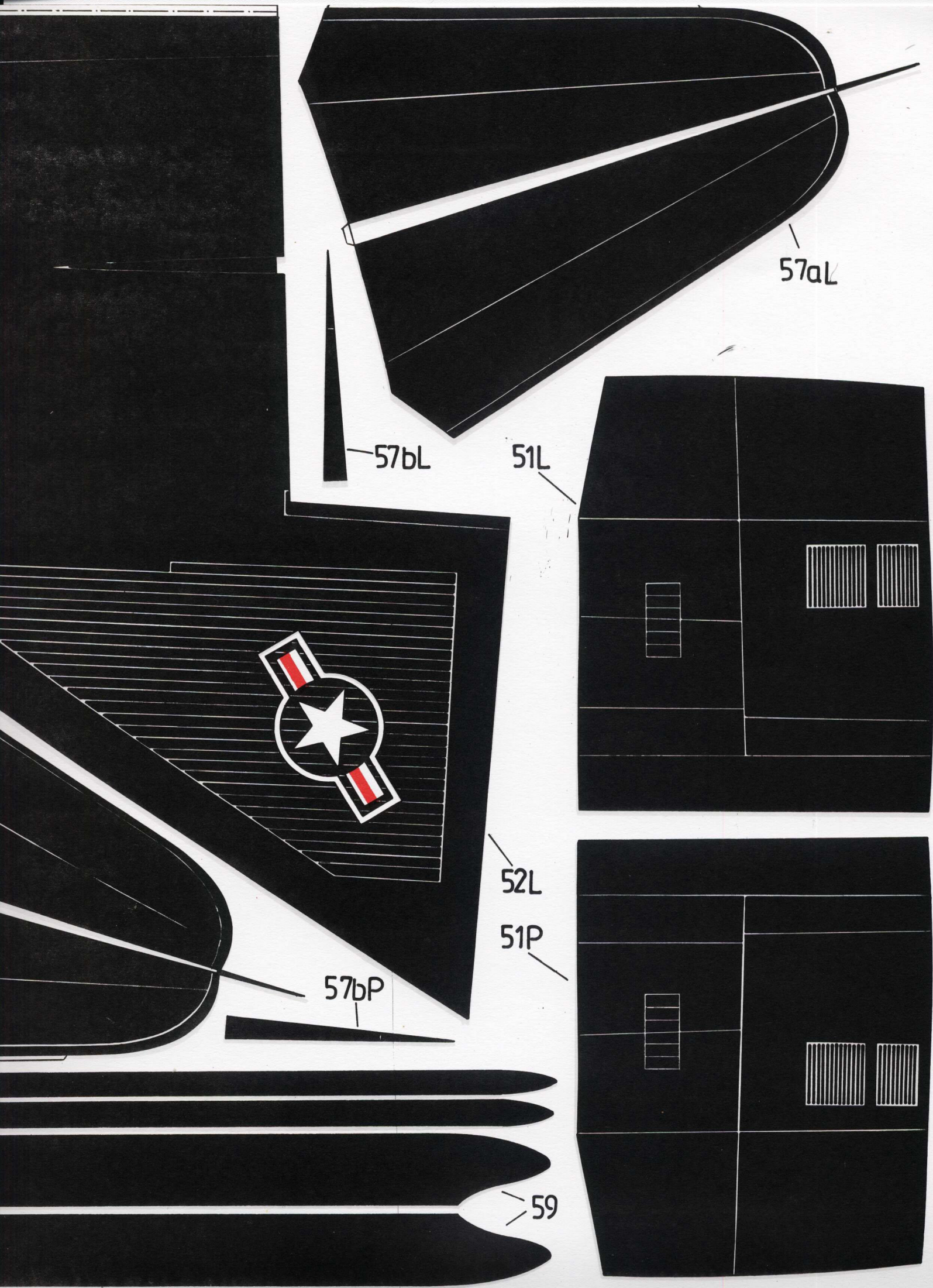

57aL

57bL

51L

52L

51P

57bP

59



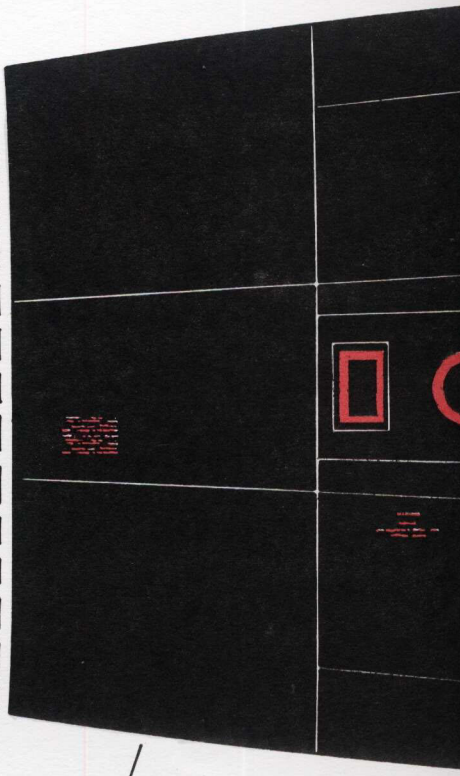
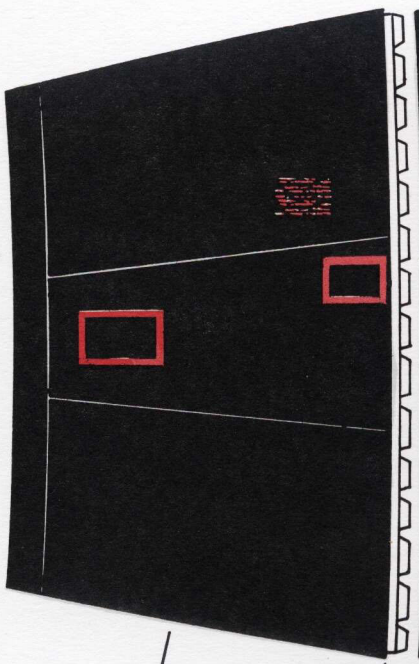
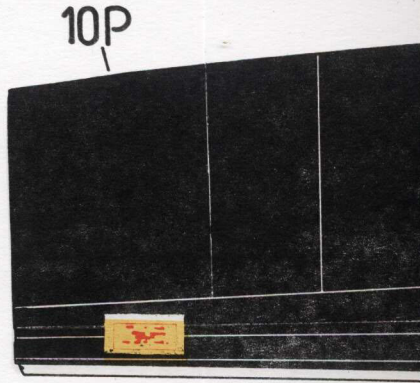
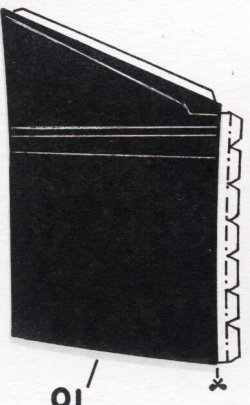
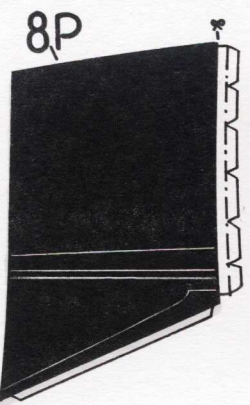
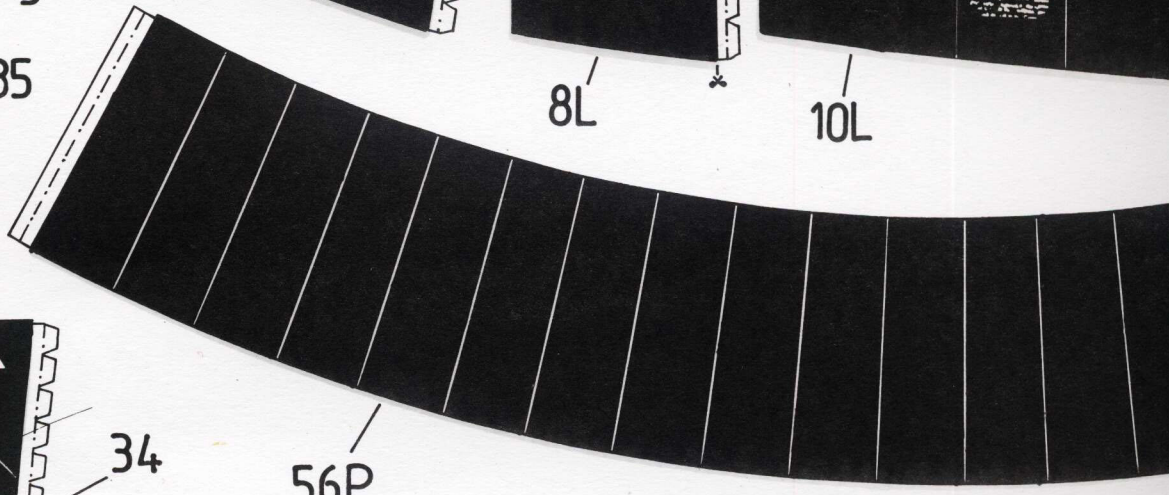
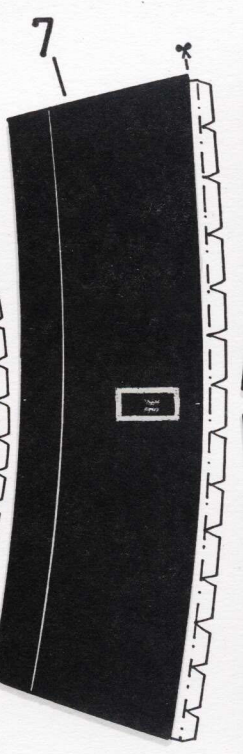
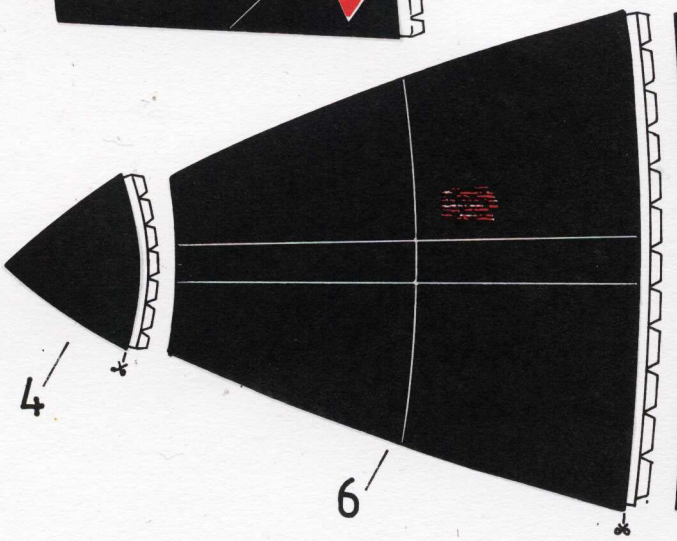
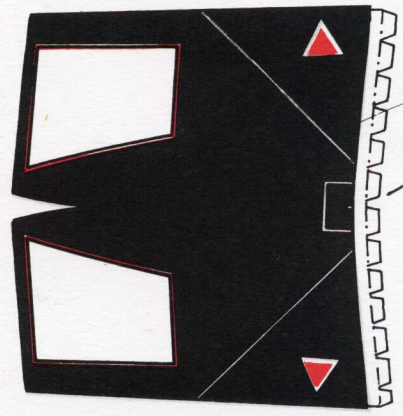
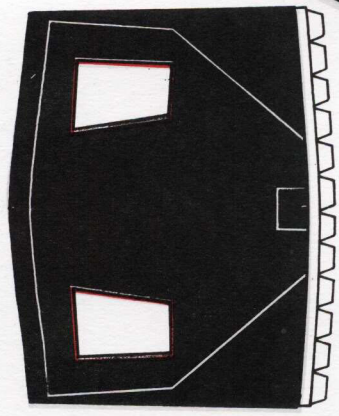
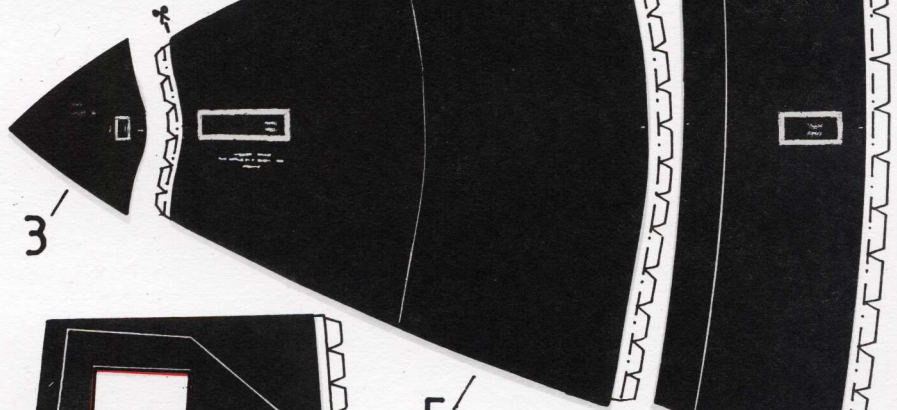
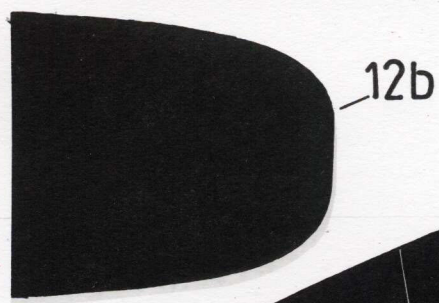



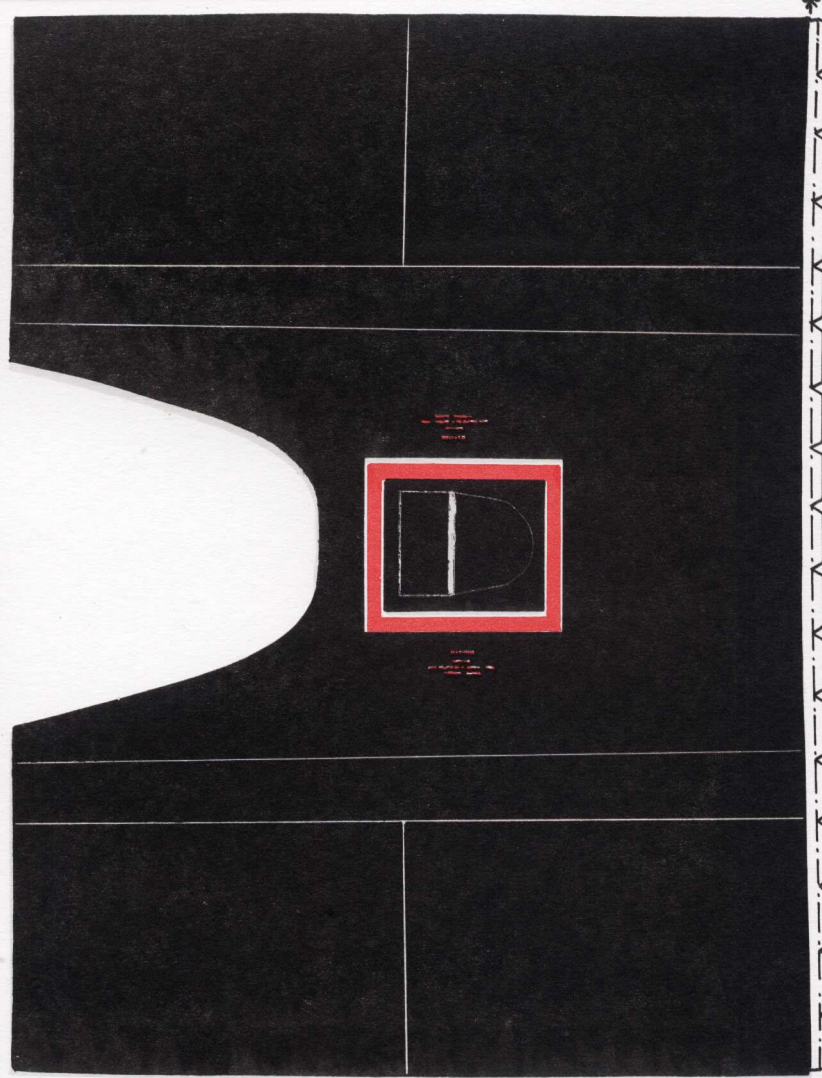
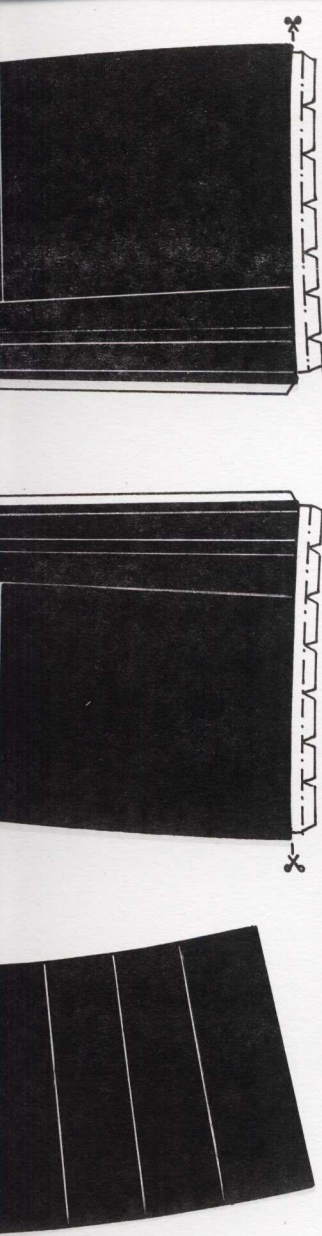

12

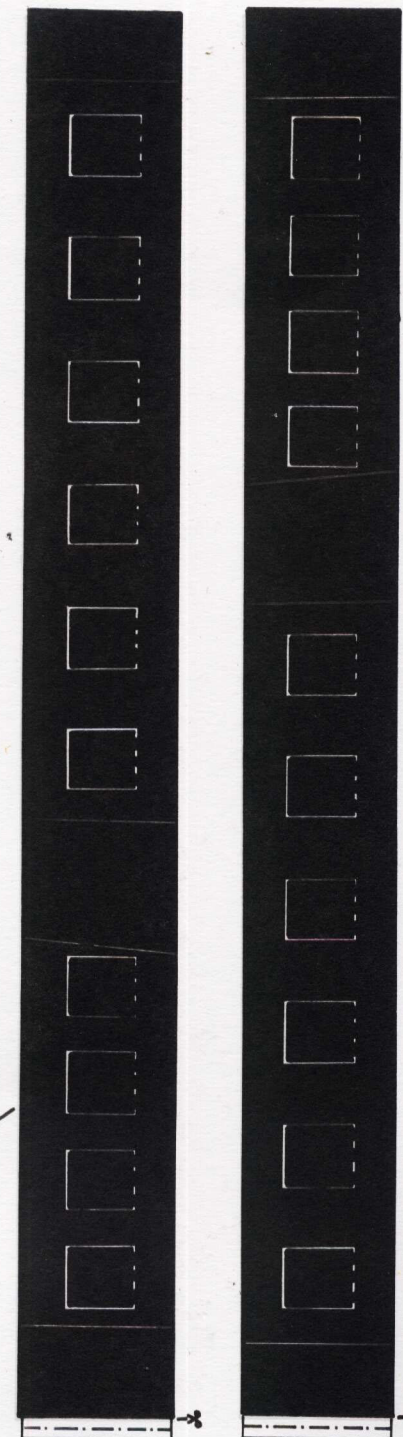

54P

54L

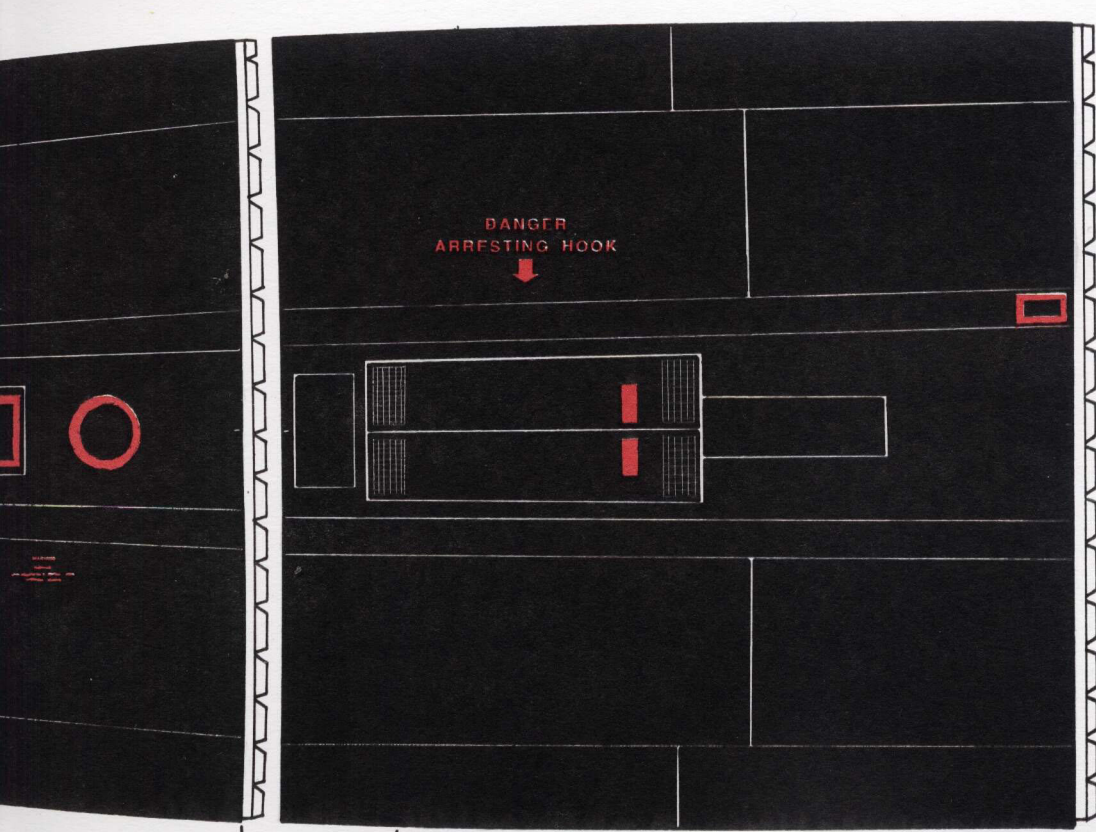

DANGER  
ARRESTING HOOK

13

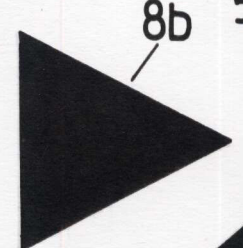

8b

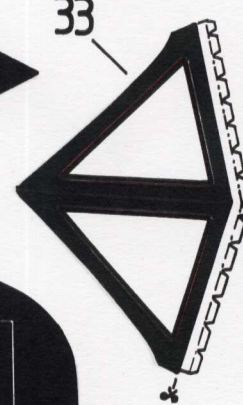

33

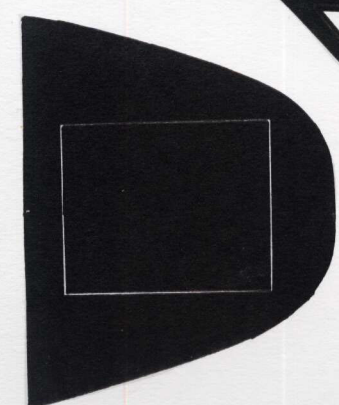

36



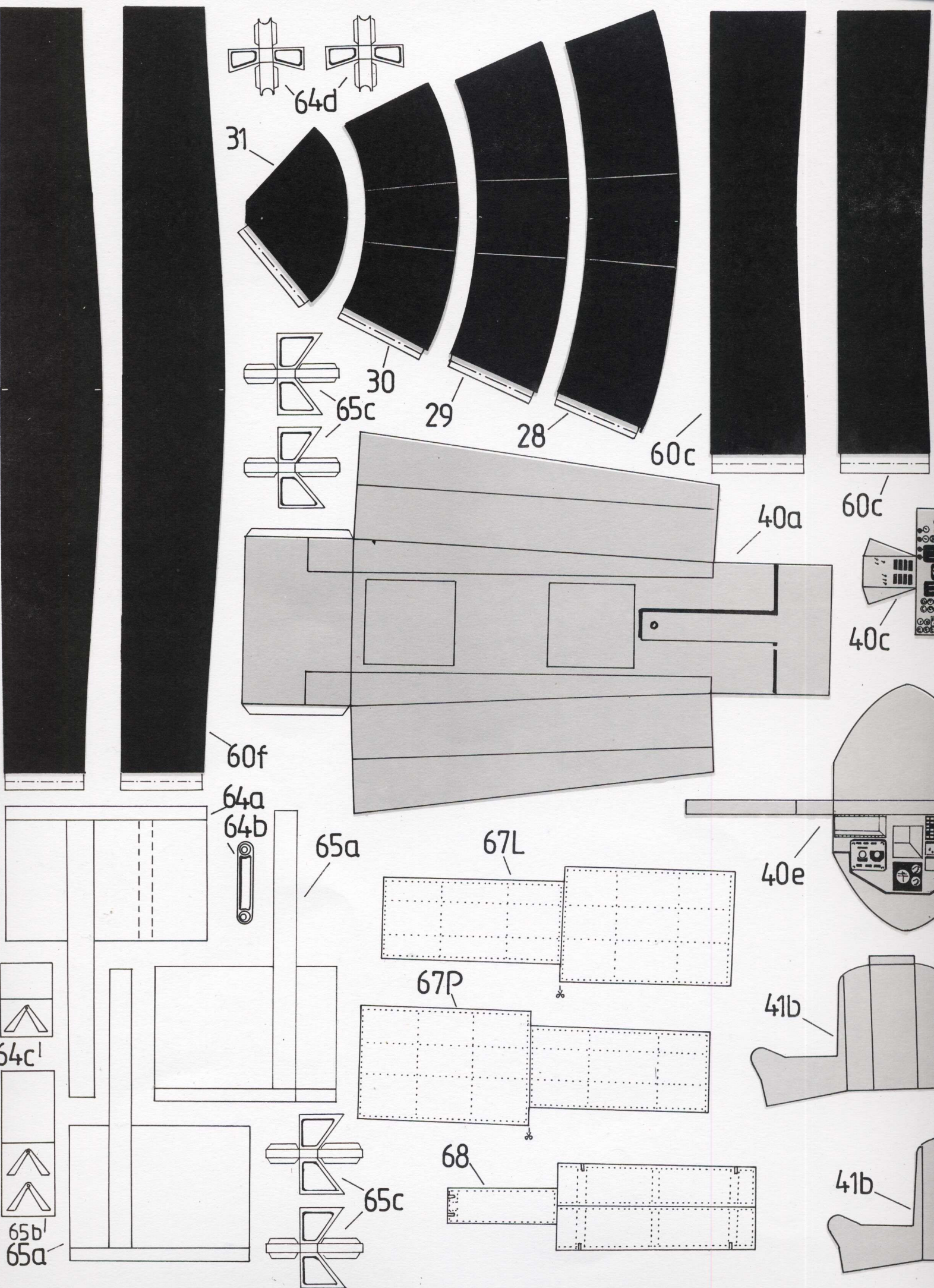



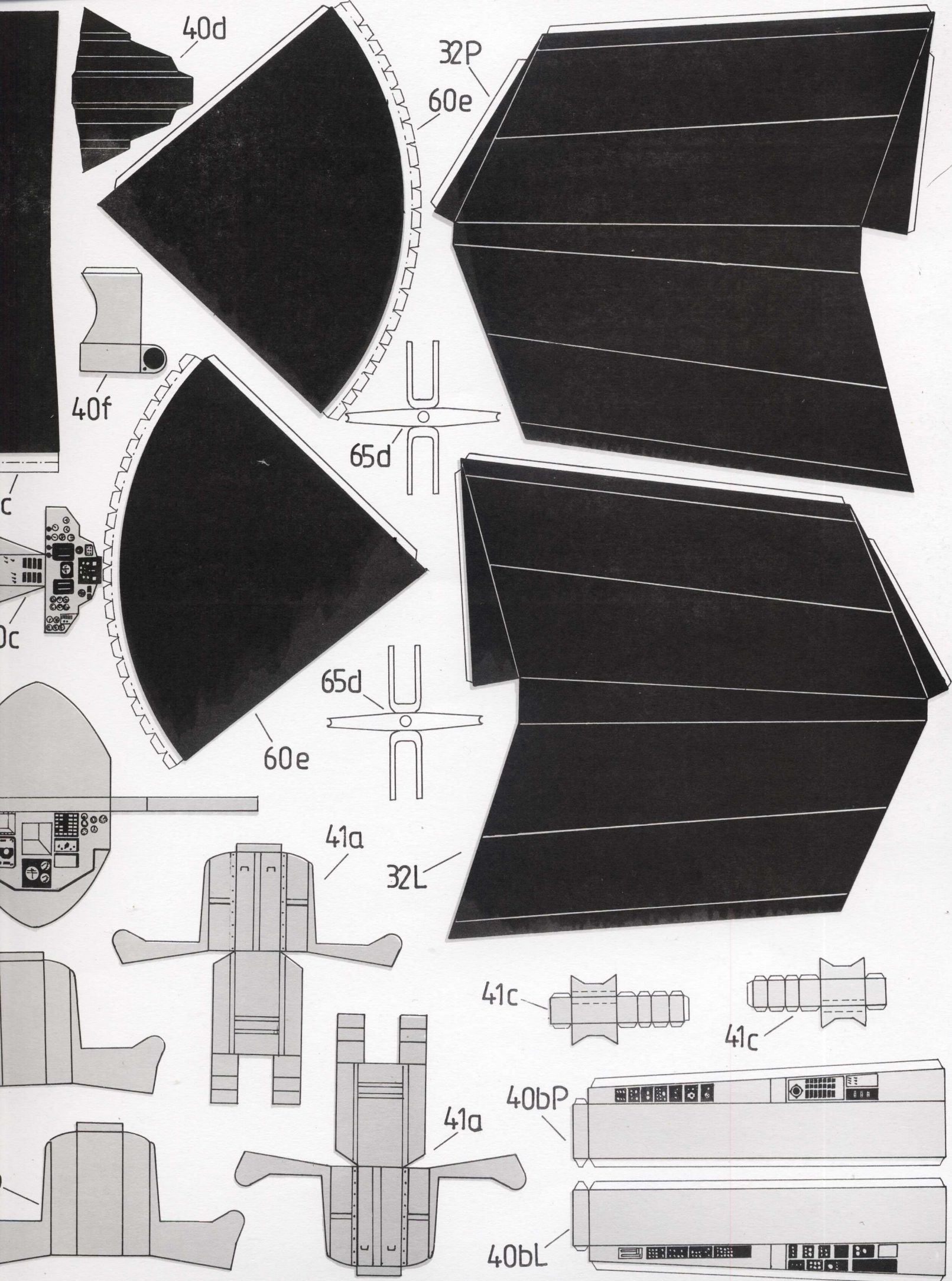



62L

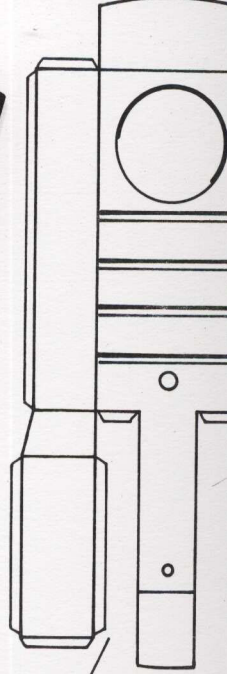

37

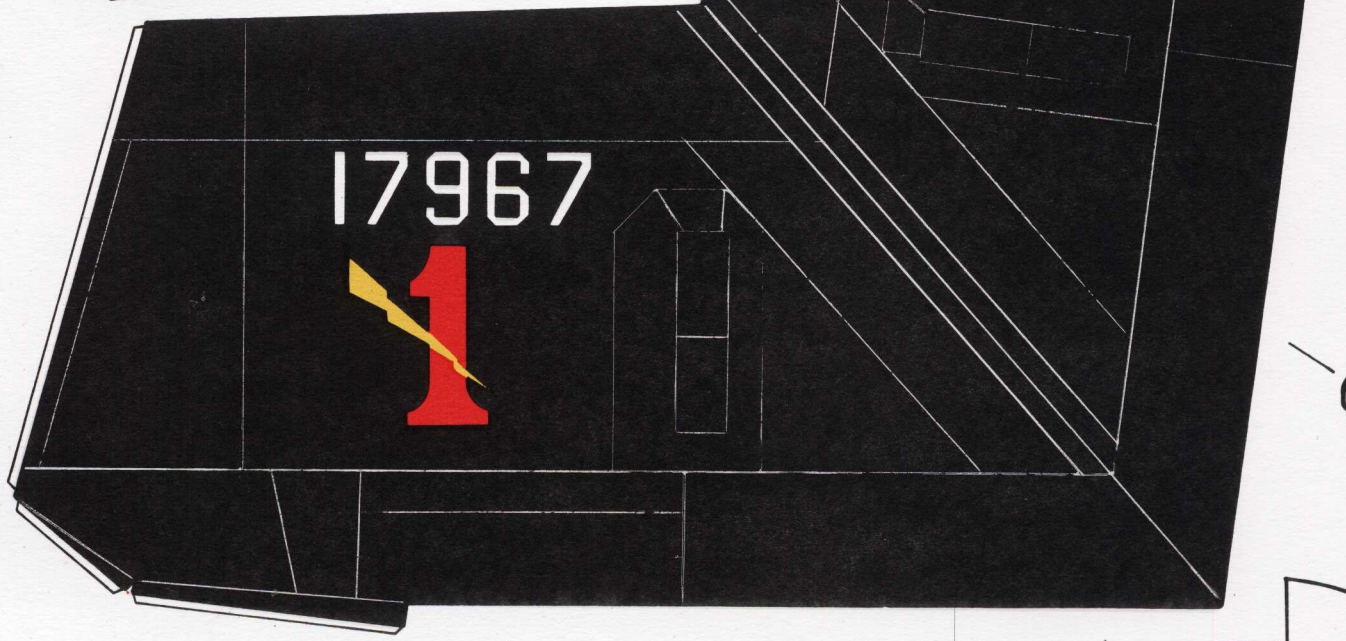

62P

63

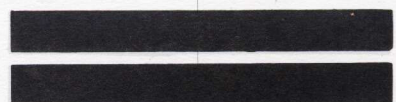

64

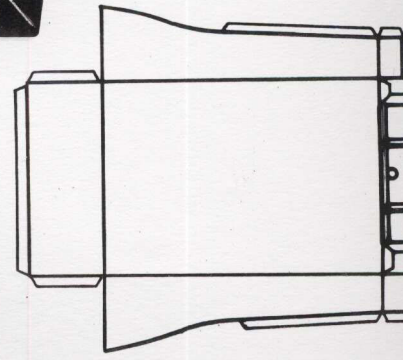
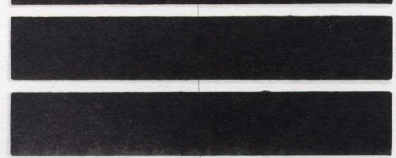



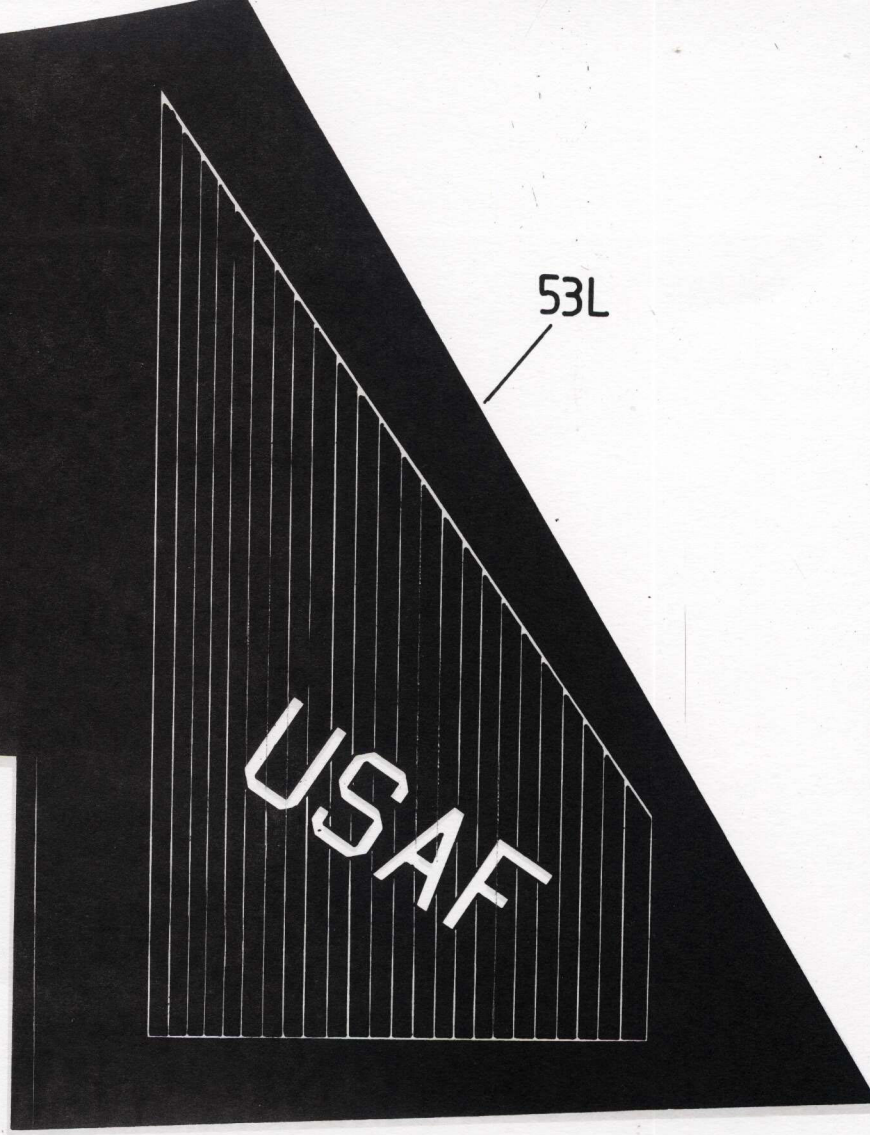
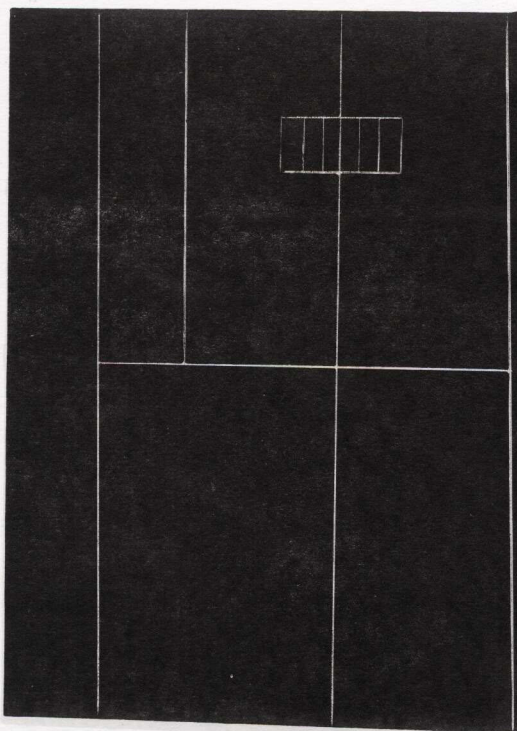
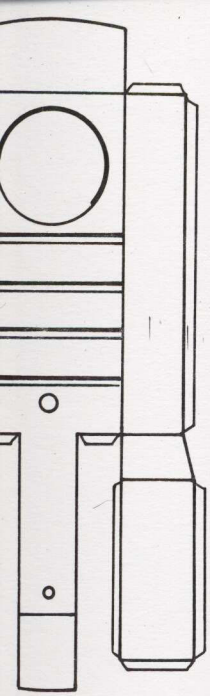

53L

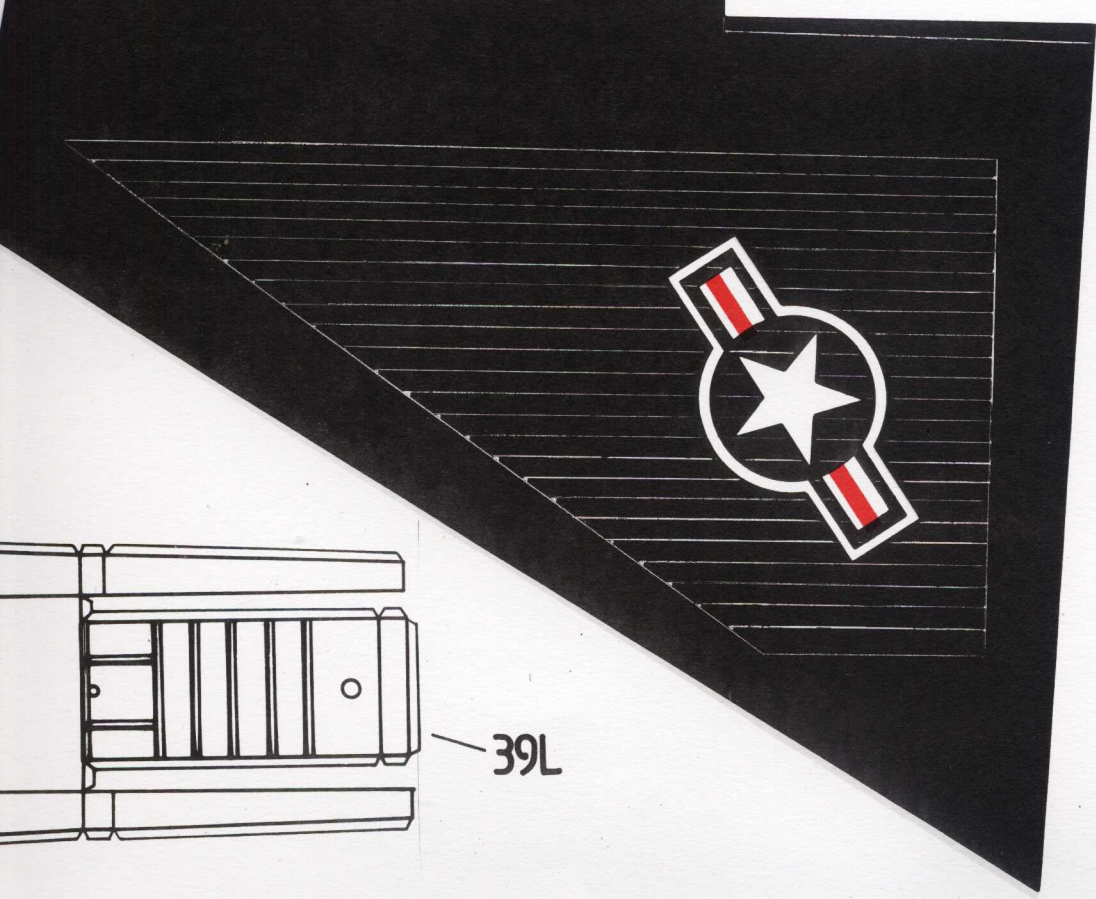
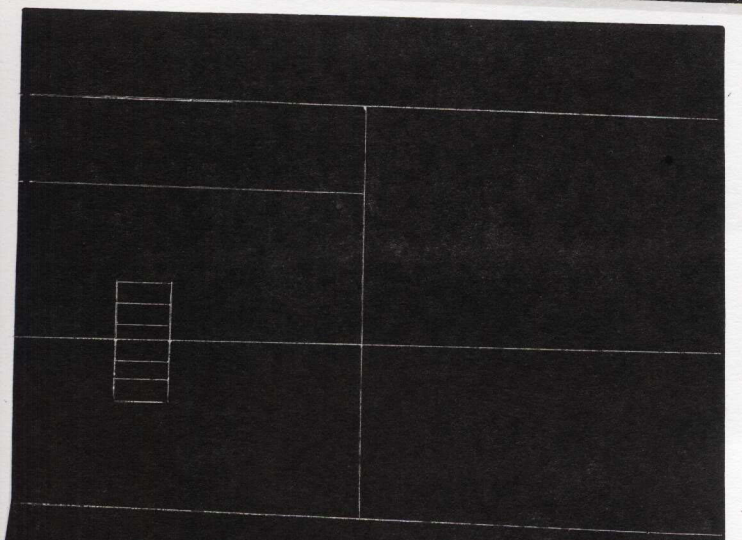

53P

38P

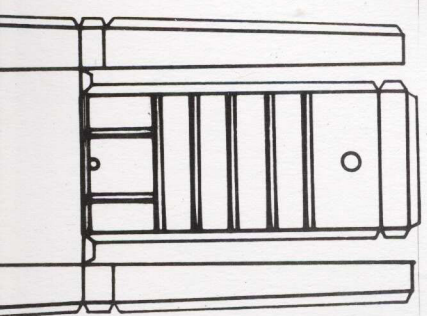
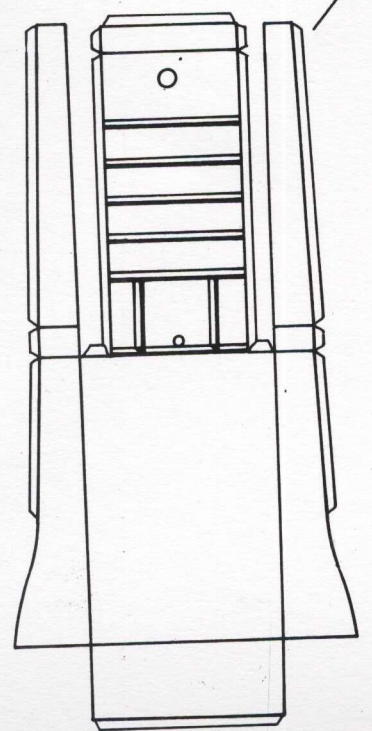

39L



U.S. AIR FORCE

U.S. AIR FORCE

14

16



NO STEP

NO STEP

15



WARNING

WARNING

55L



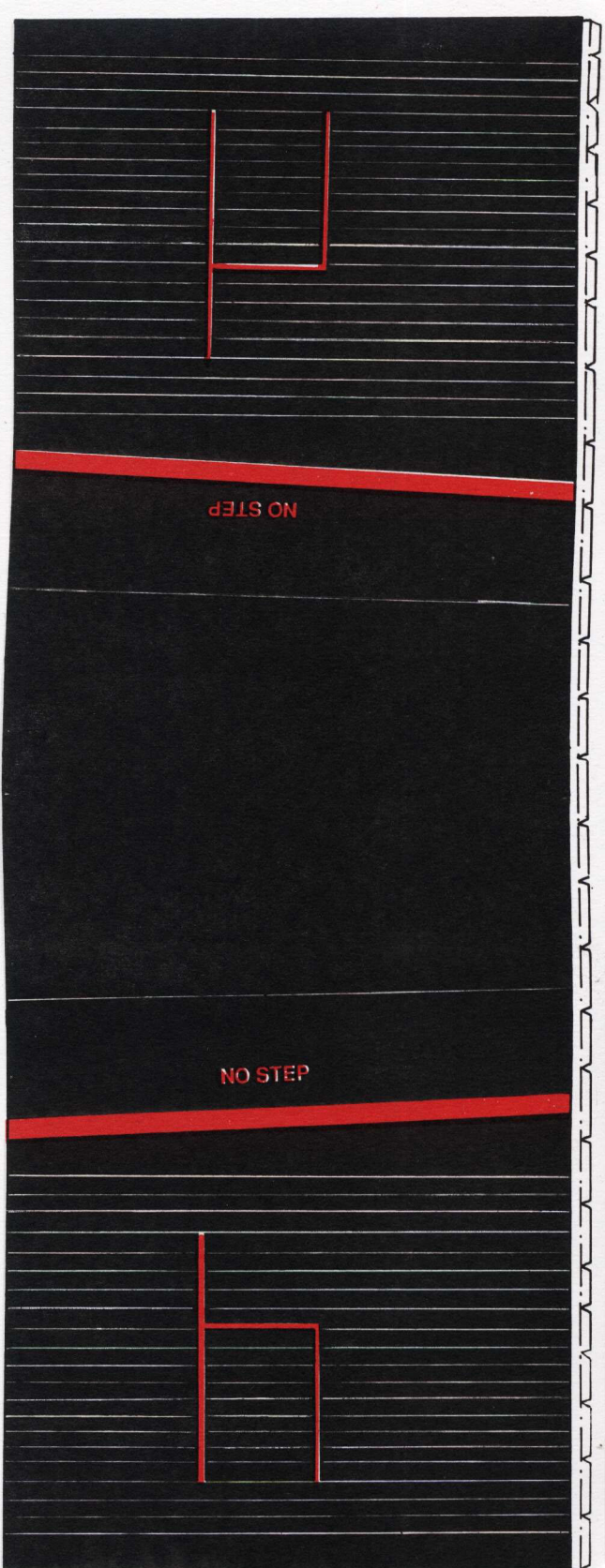
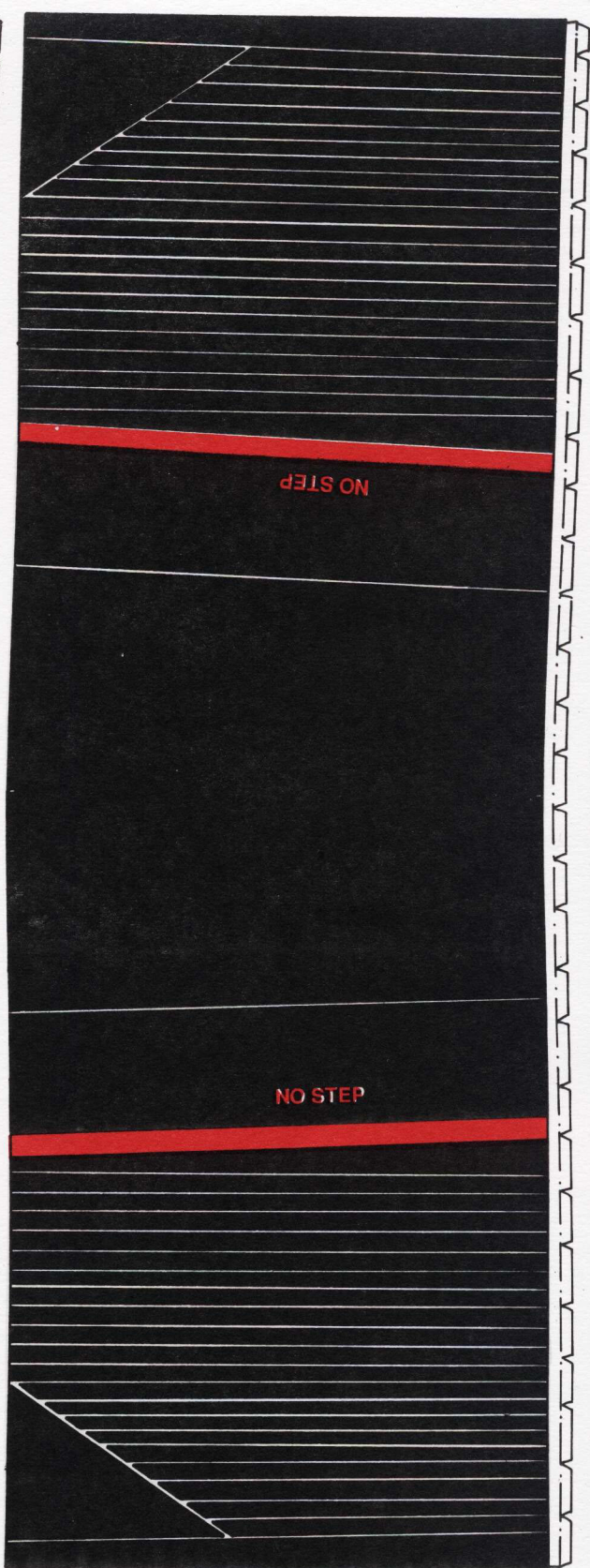
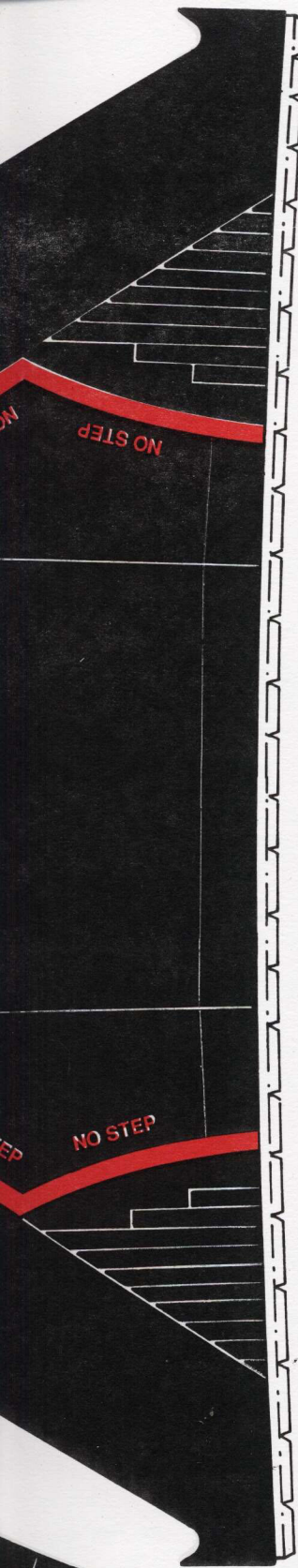

18

20

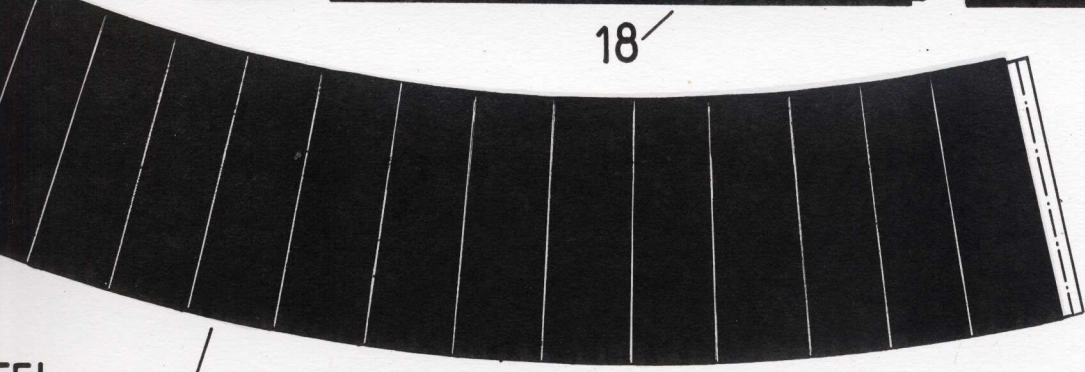

55L

56L



44P

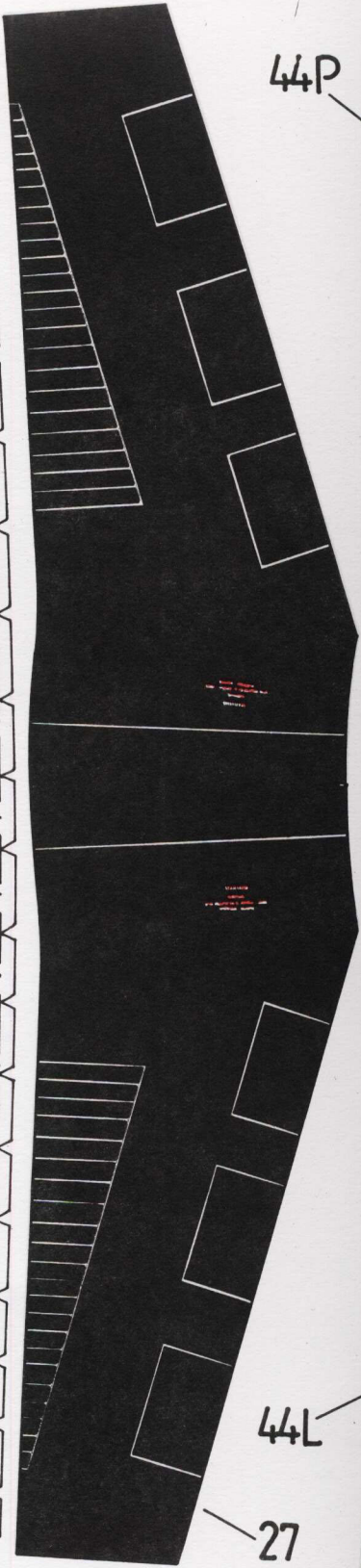
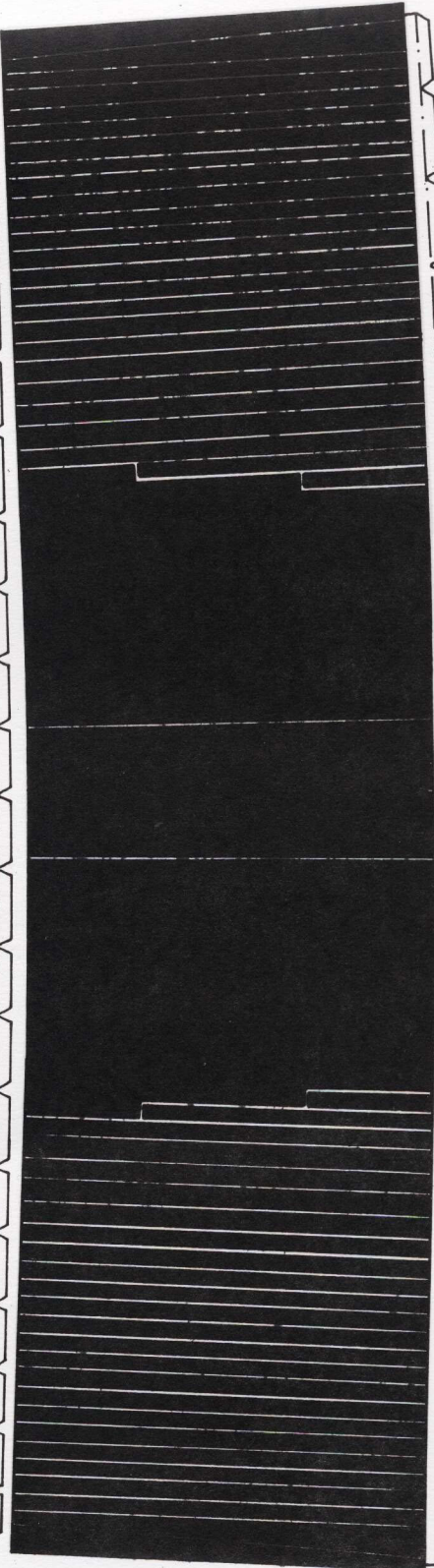
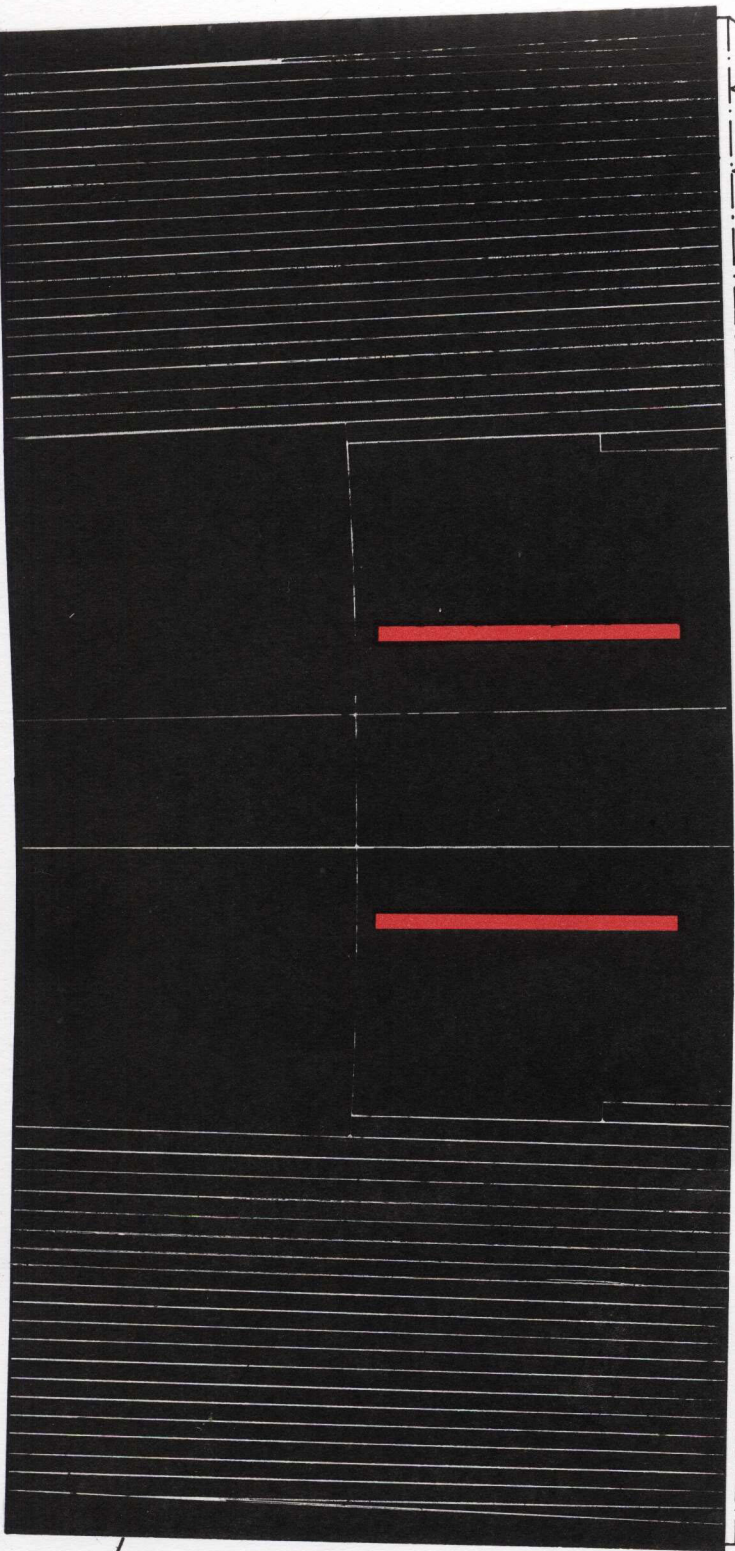

23

45P

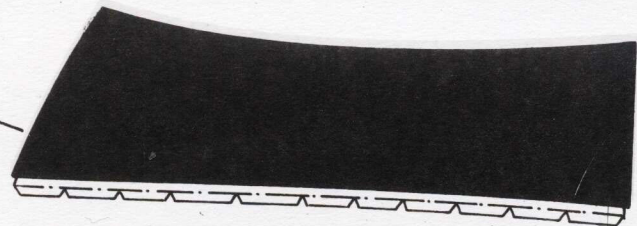

47P

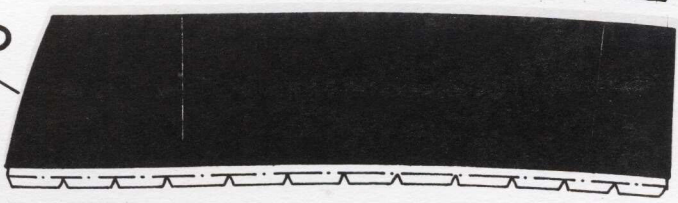

25

45L

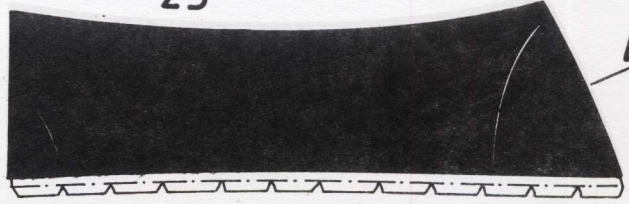

47L

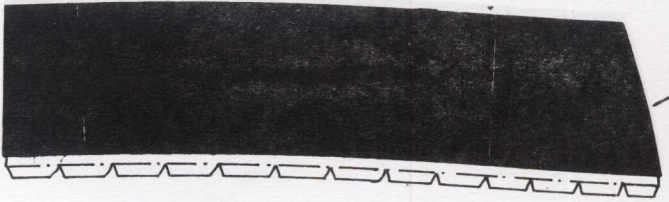

44L

27

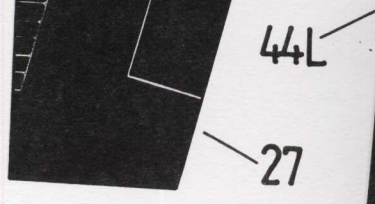



44P

46P

48P

967

50P

4L

7

7L

46L

48L

967

50L

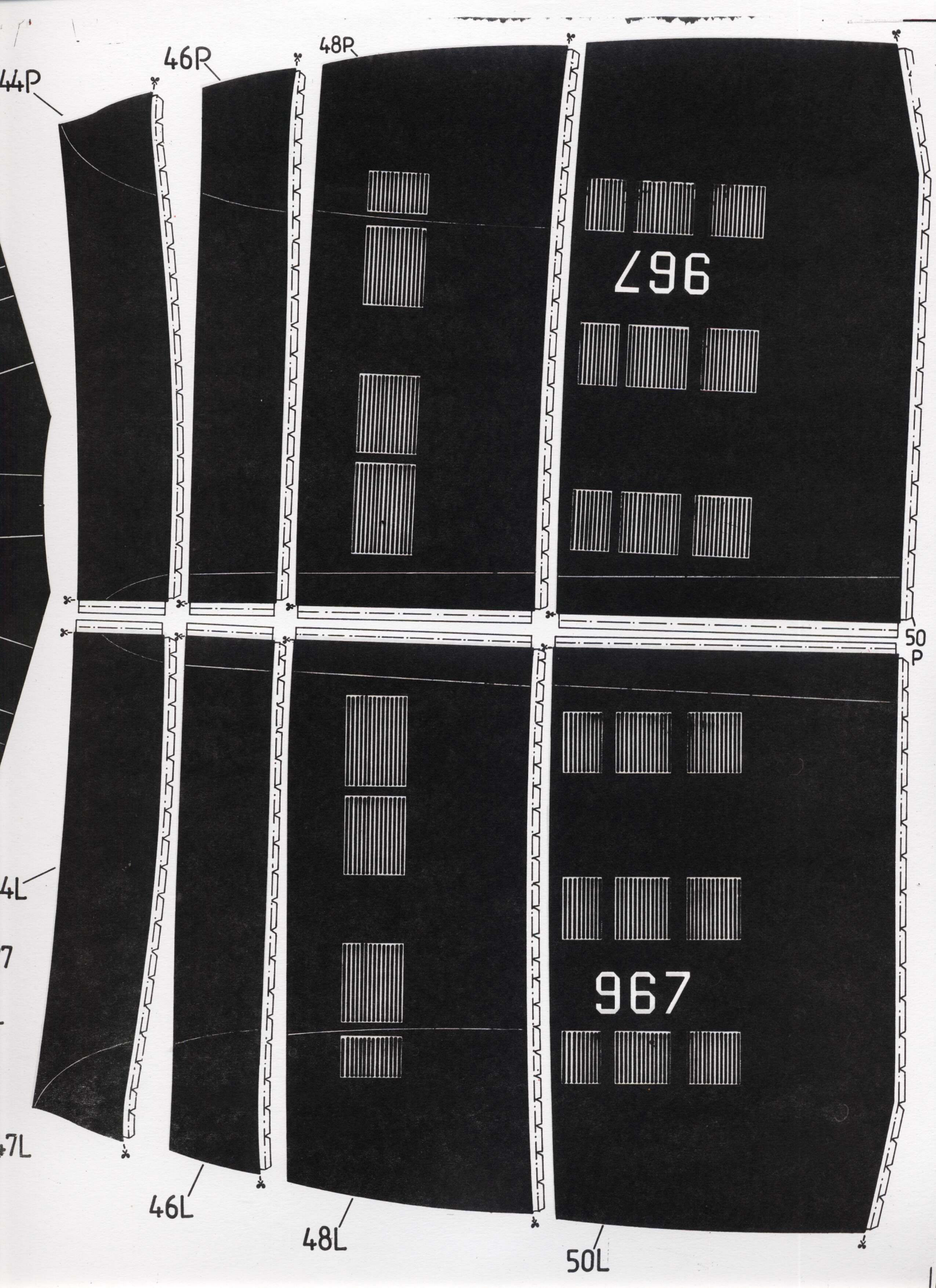



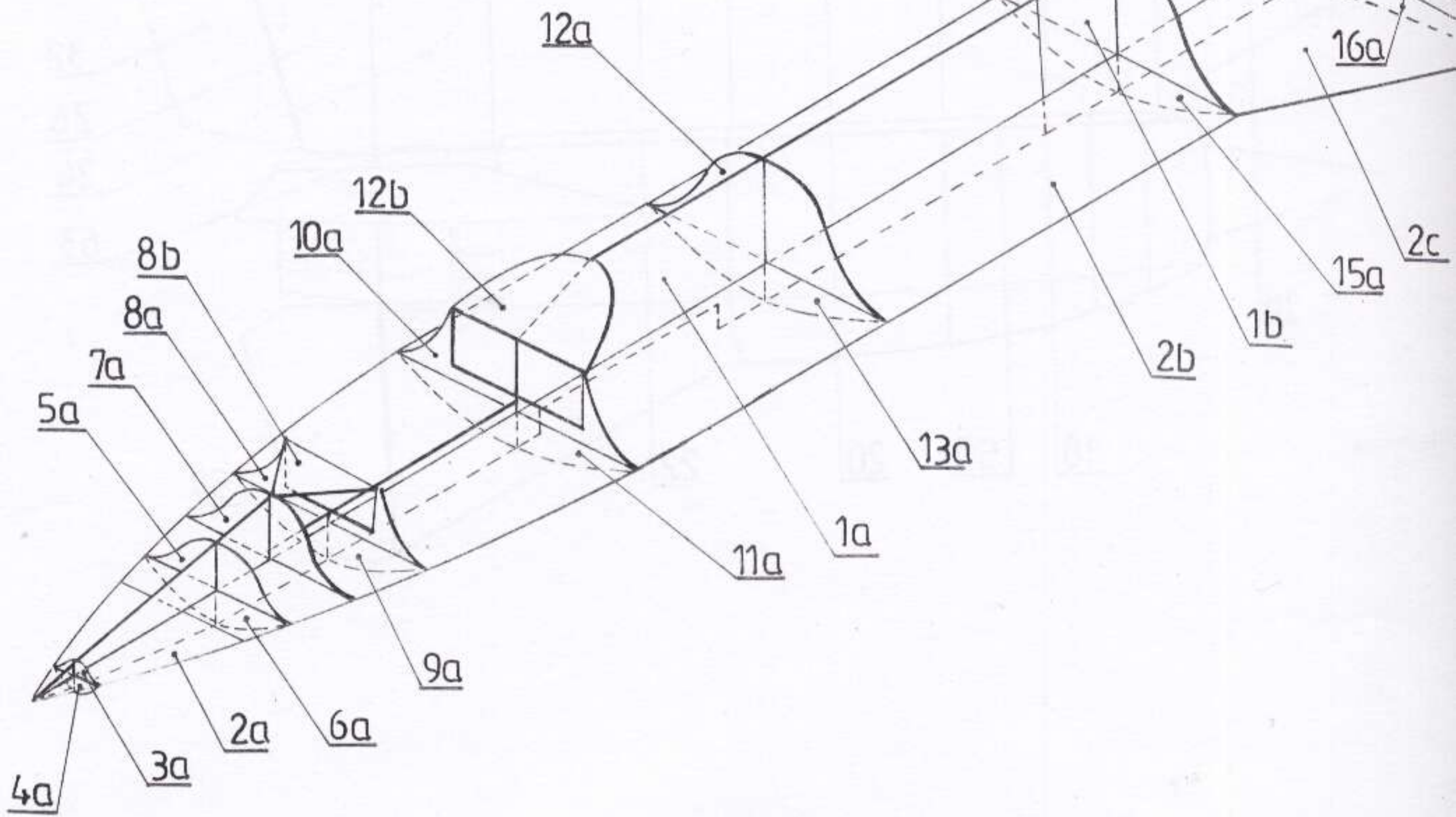
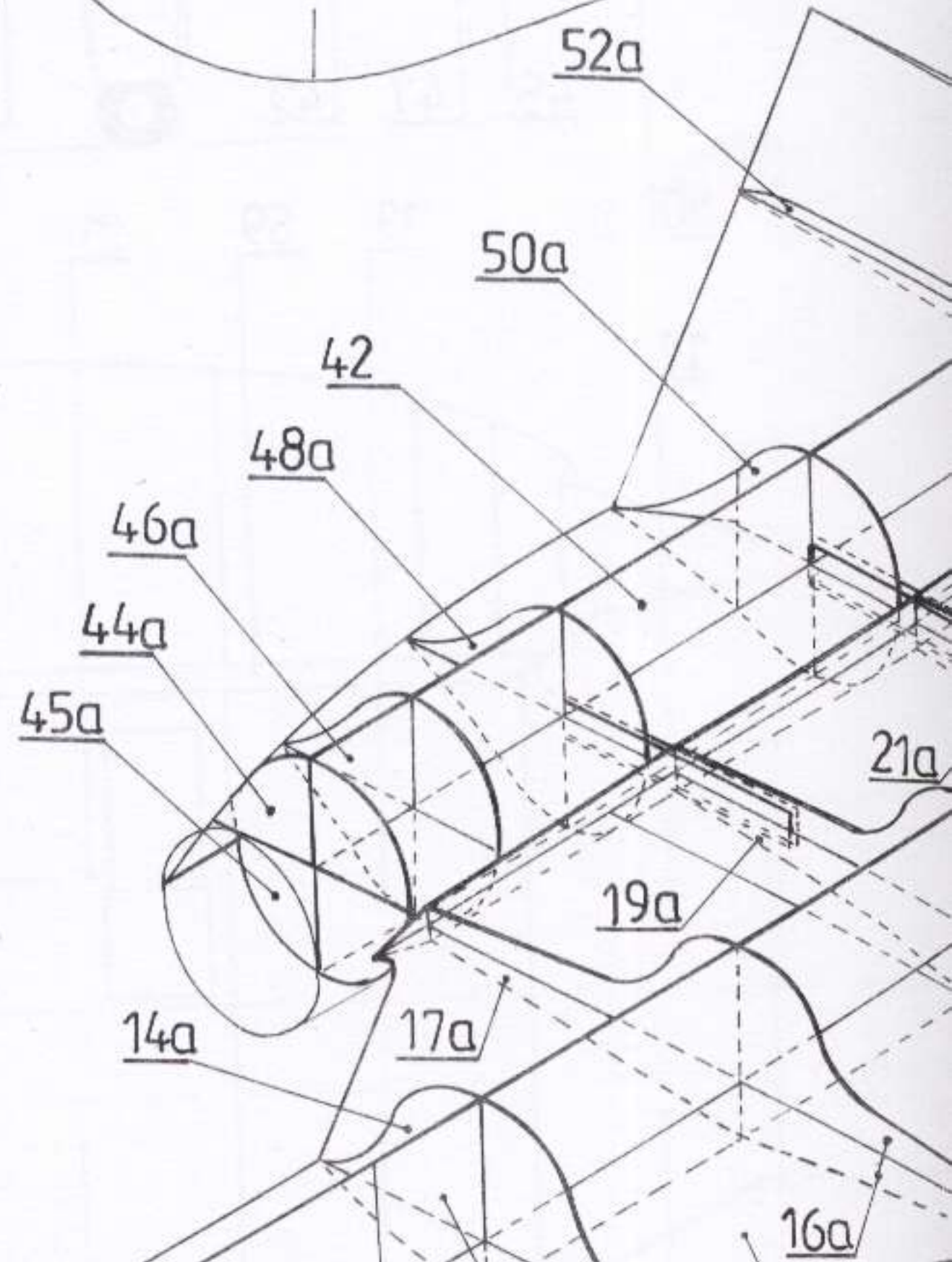
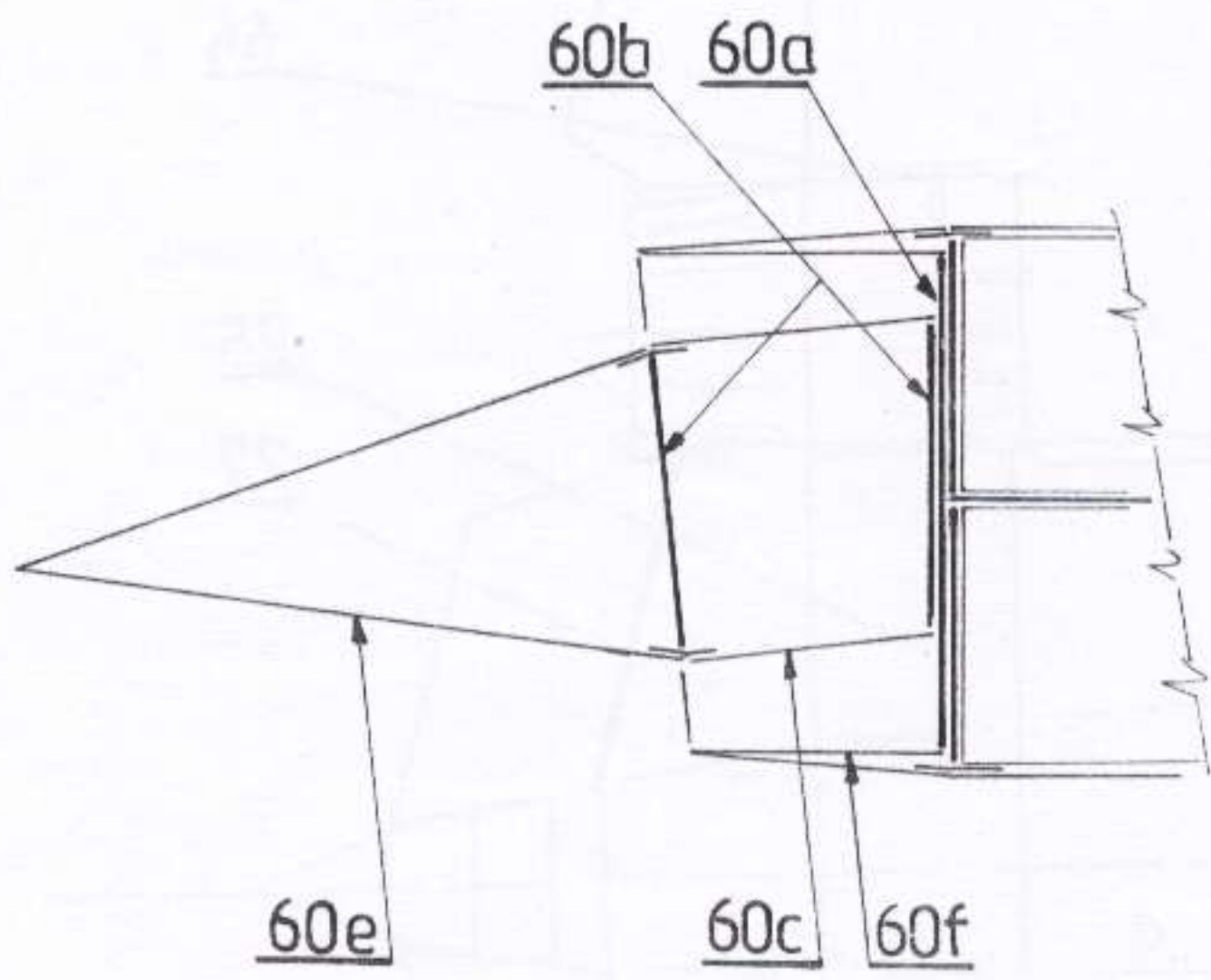
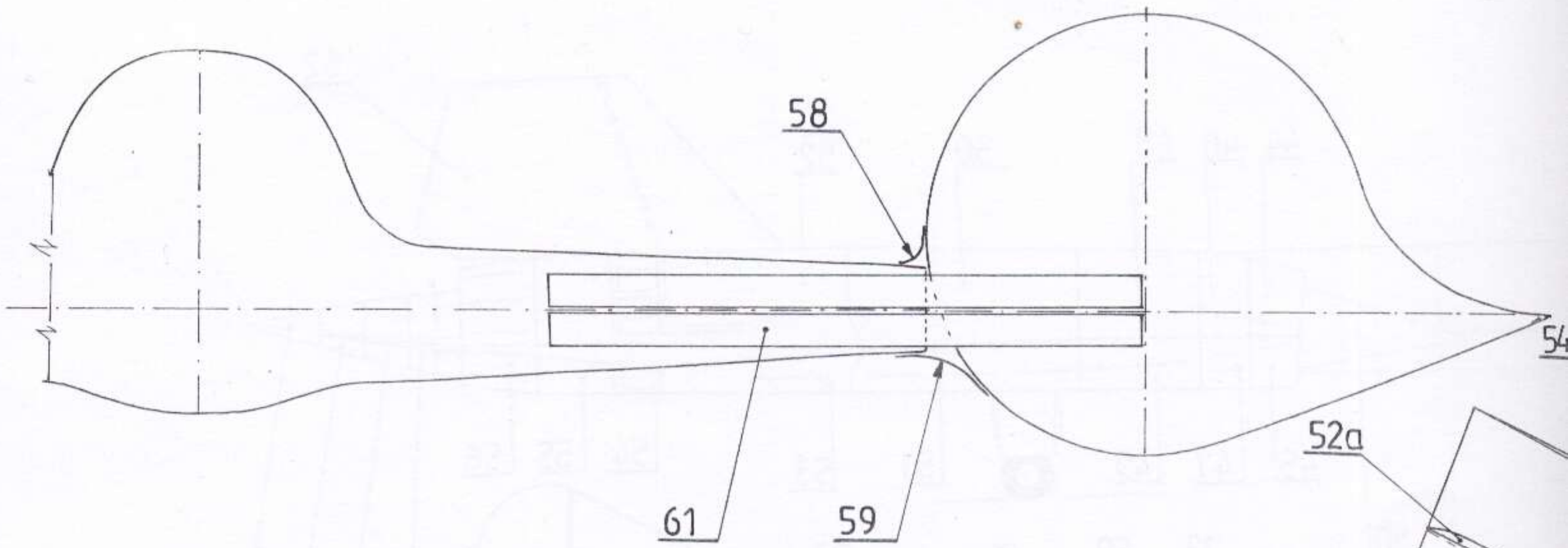



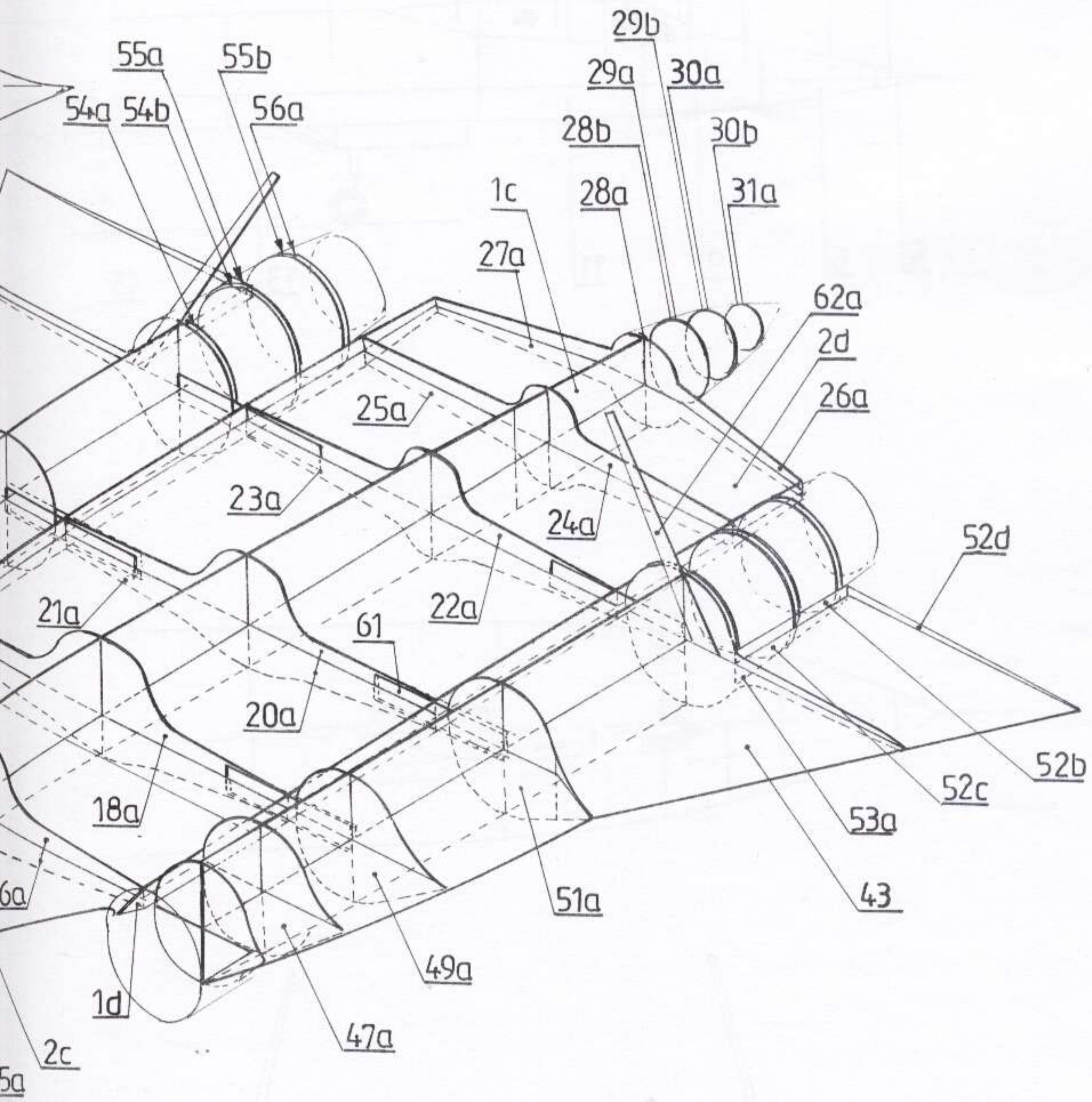



# Lockheed SR 71 BLACK BIRD

