

1:33 MODEL KARTONOWY

GPM

NR
2

Commonwealth
BOOMERANG



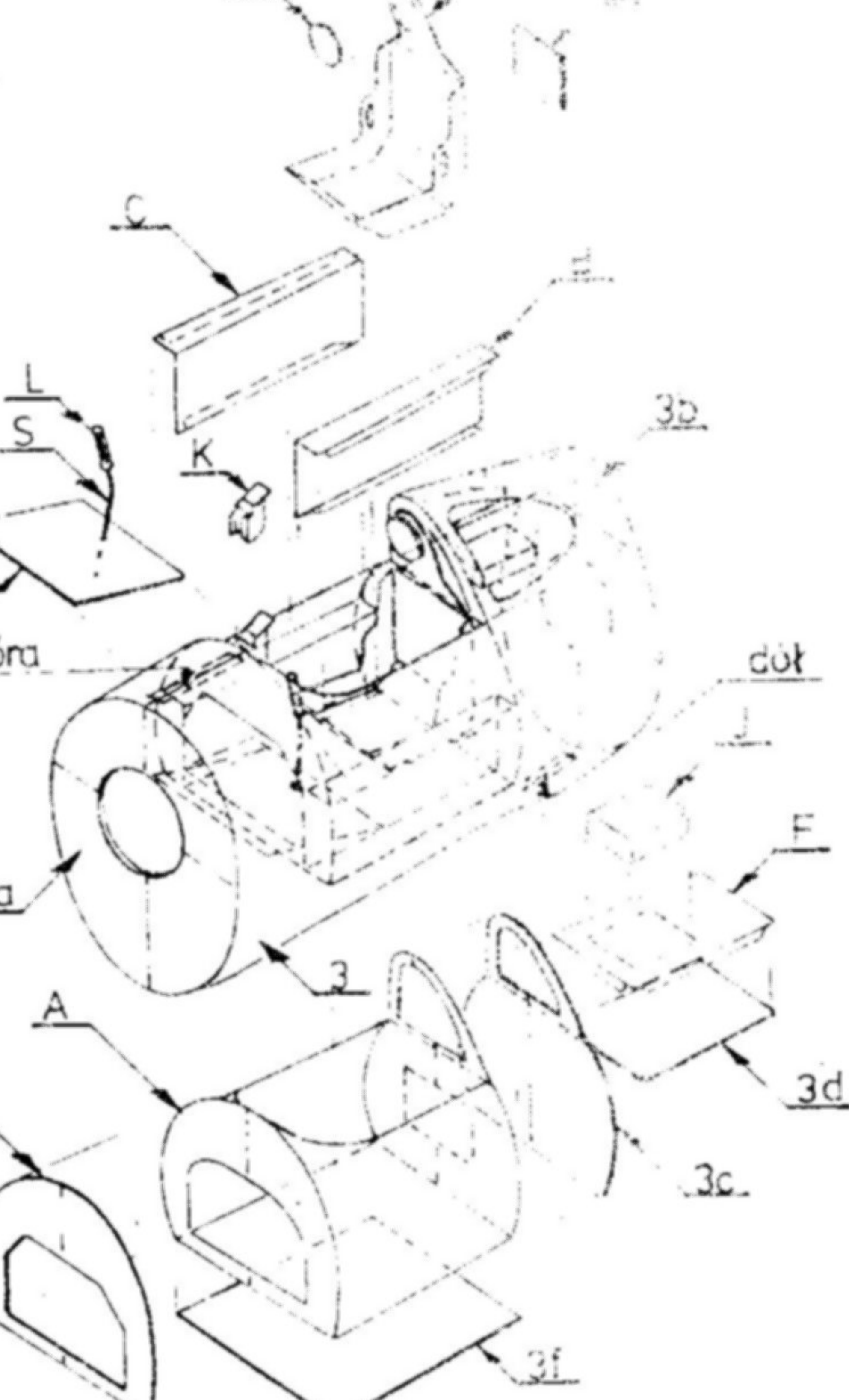
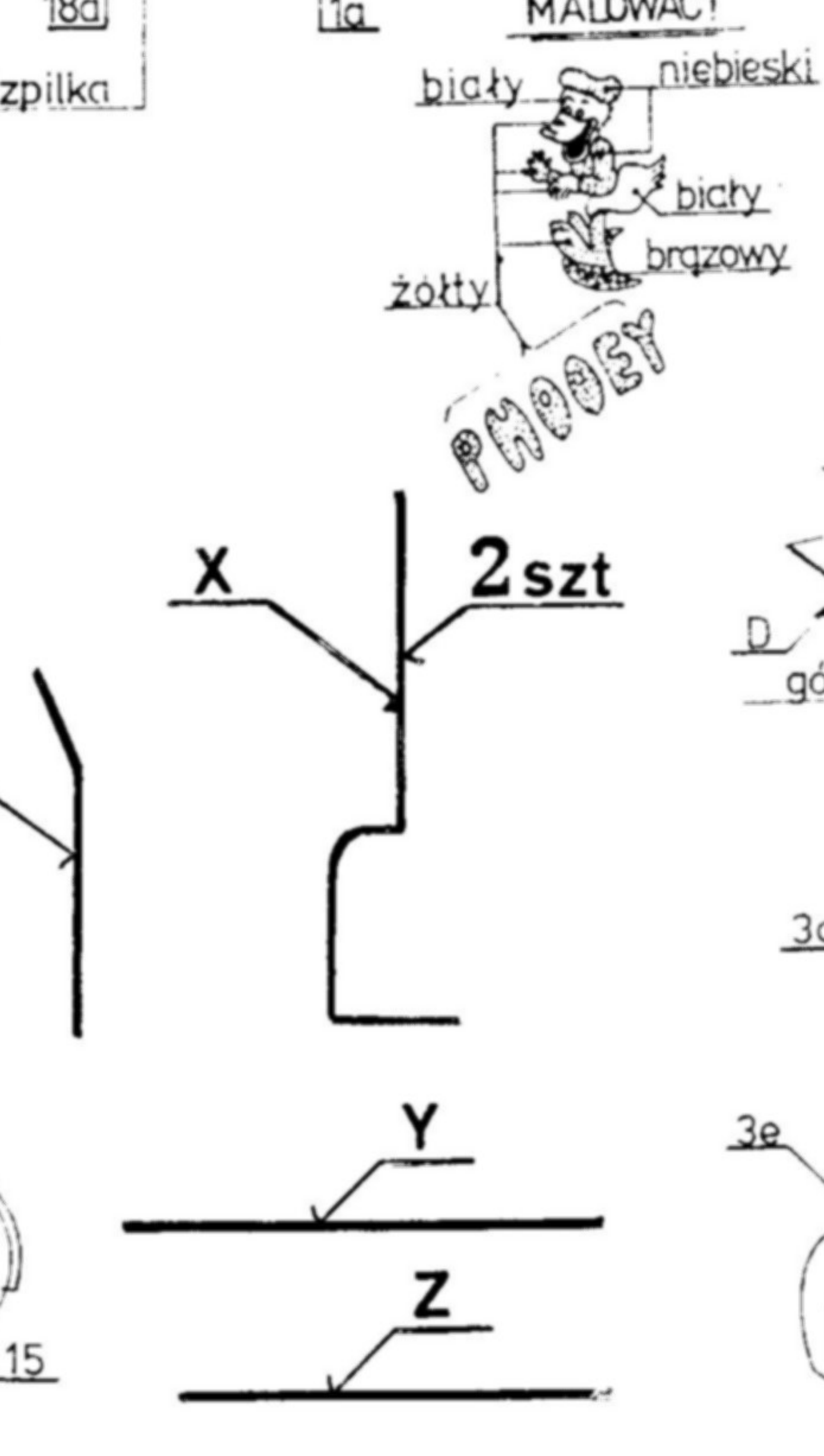
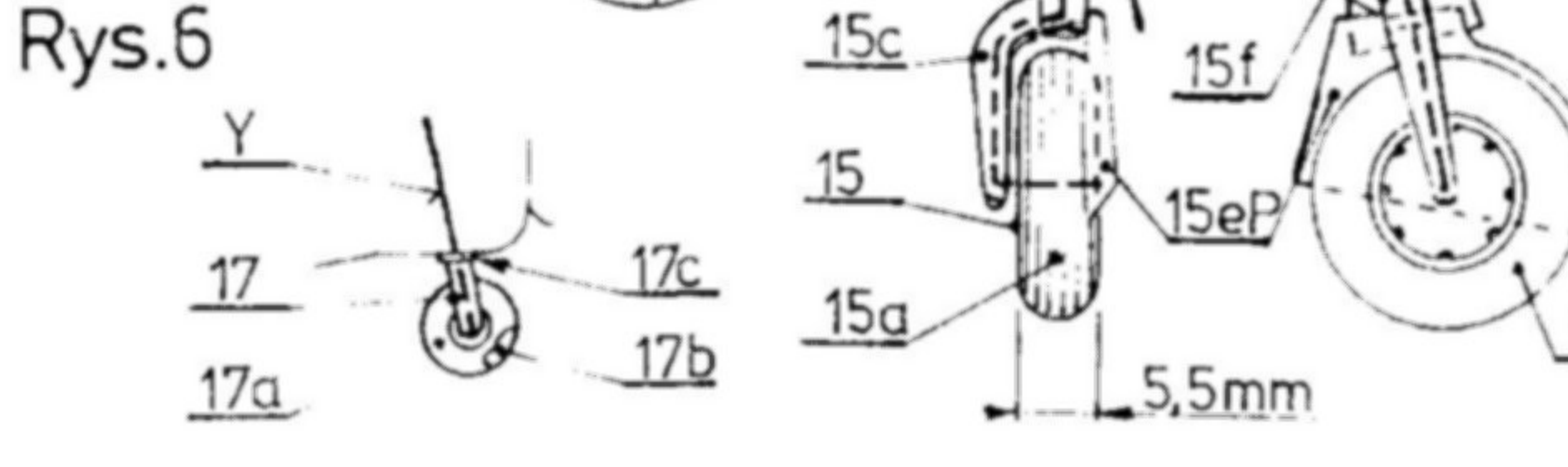
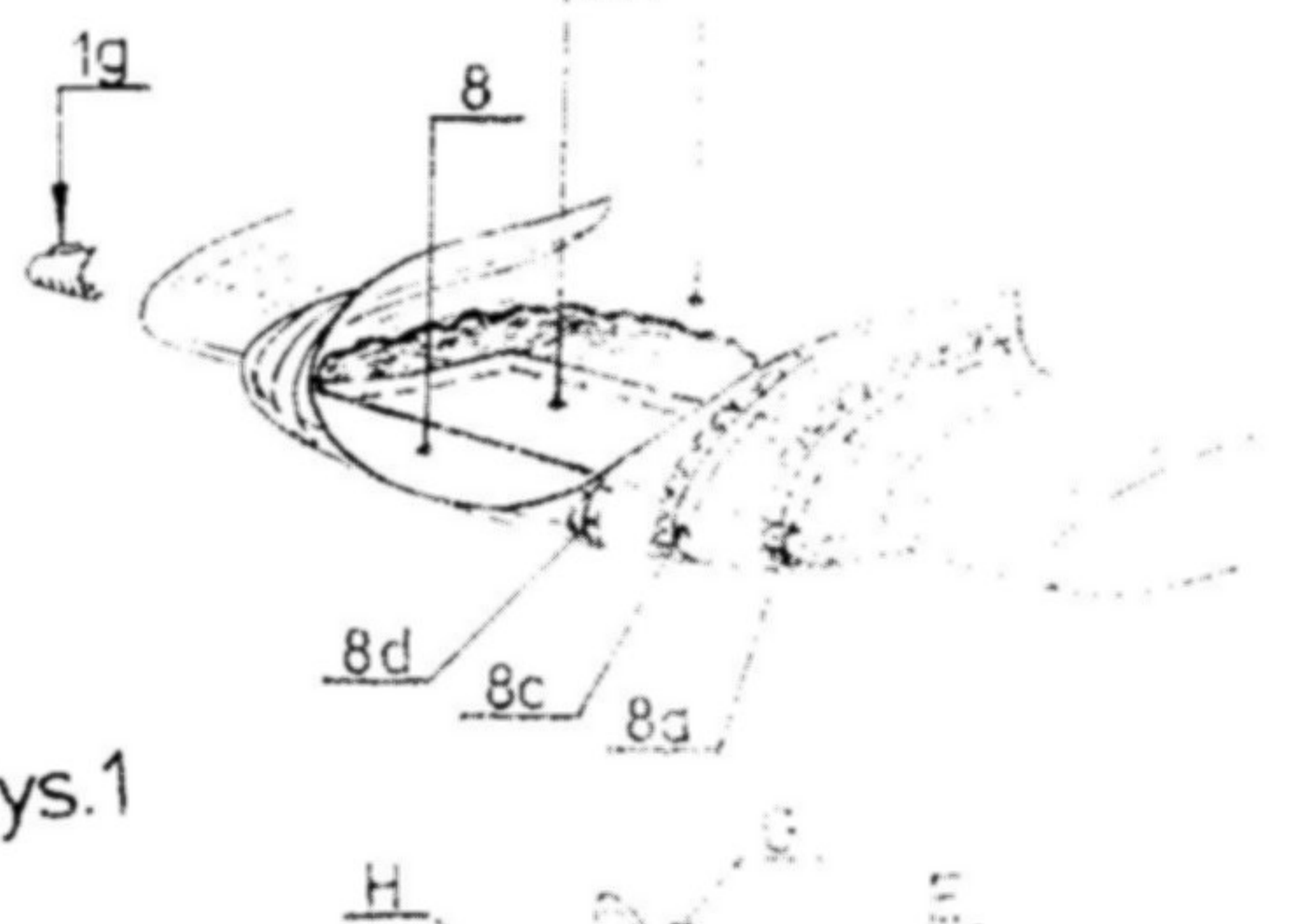
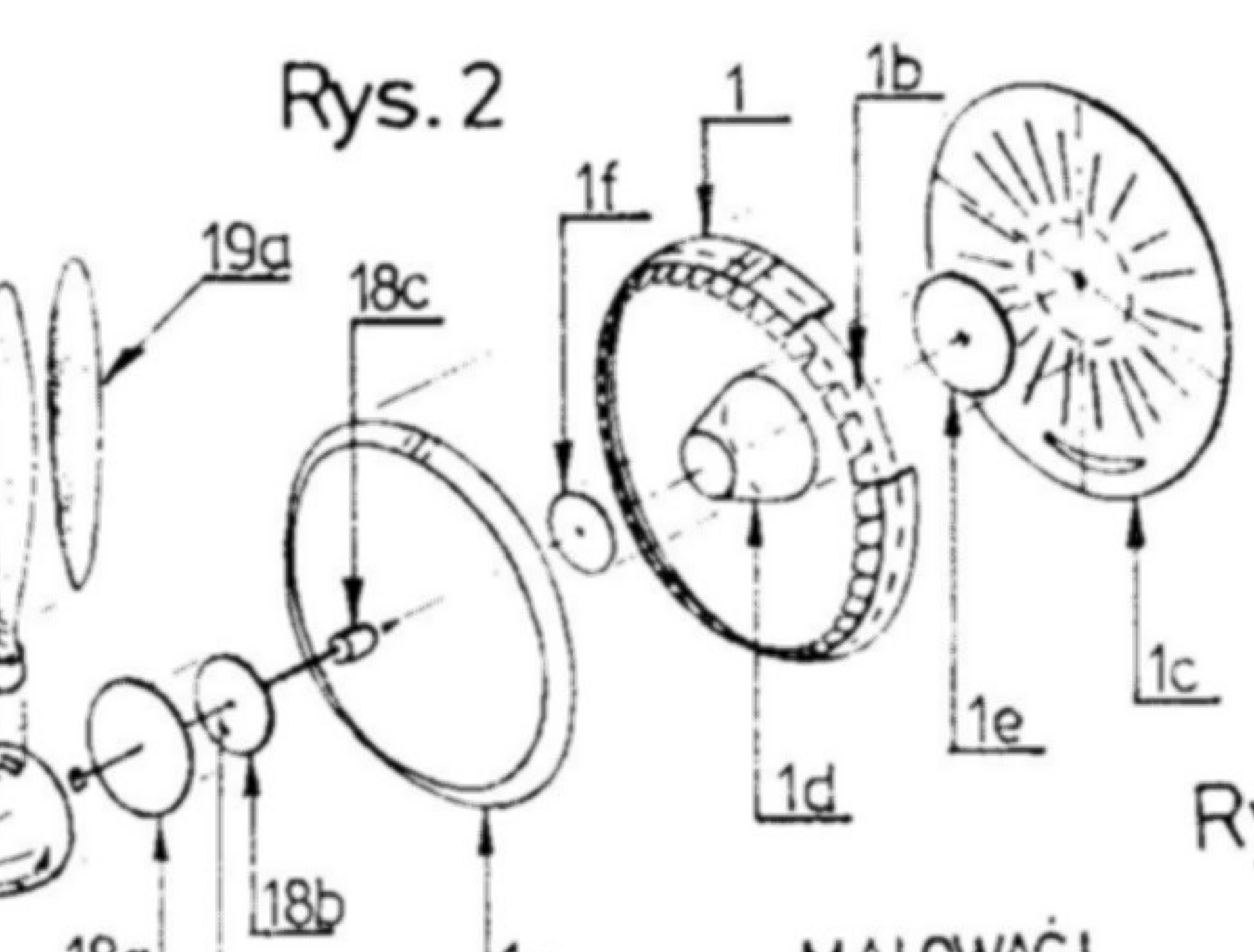
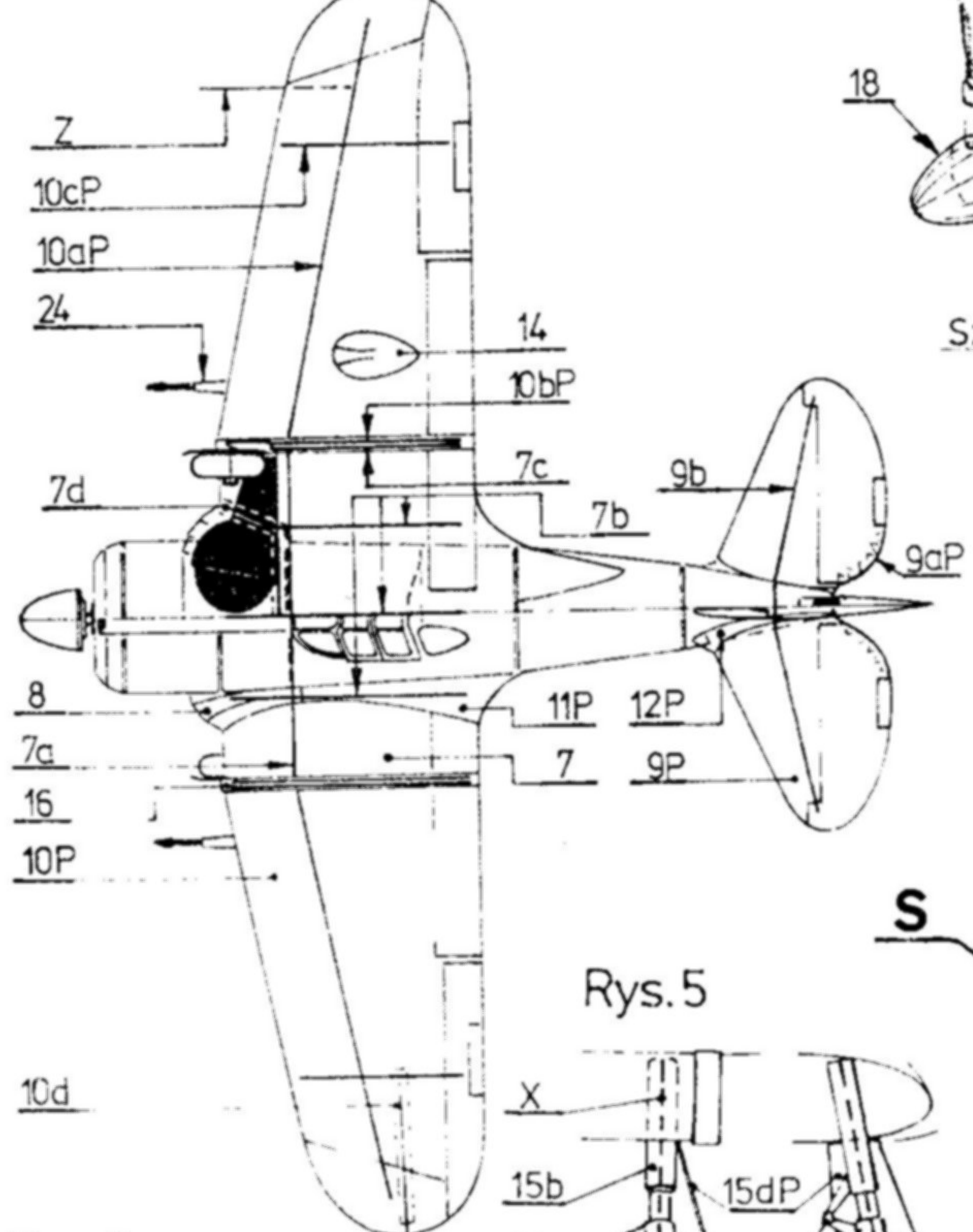
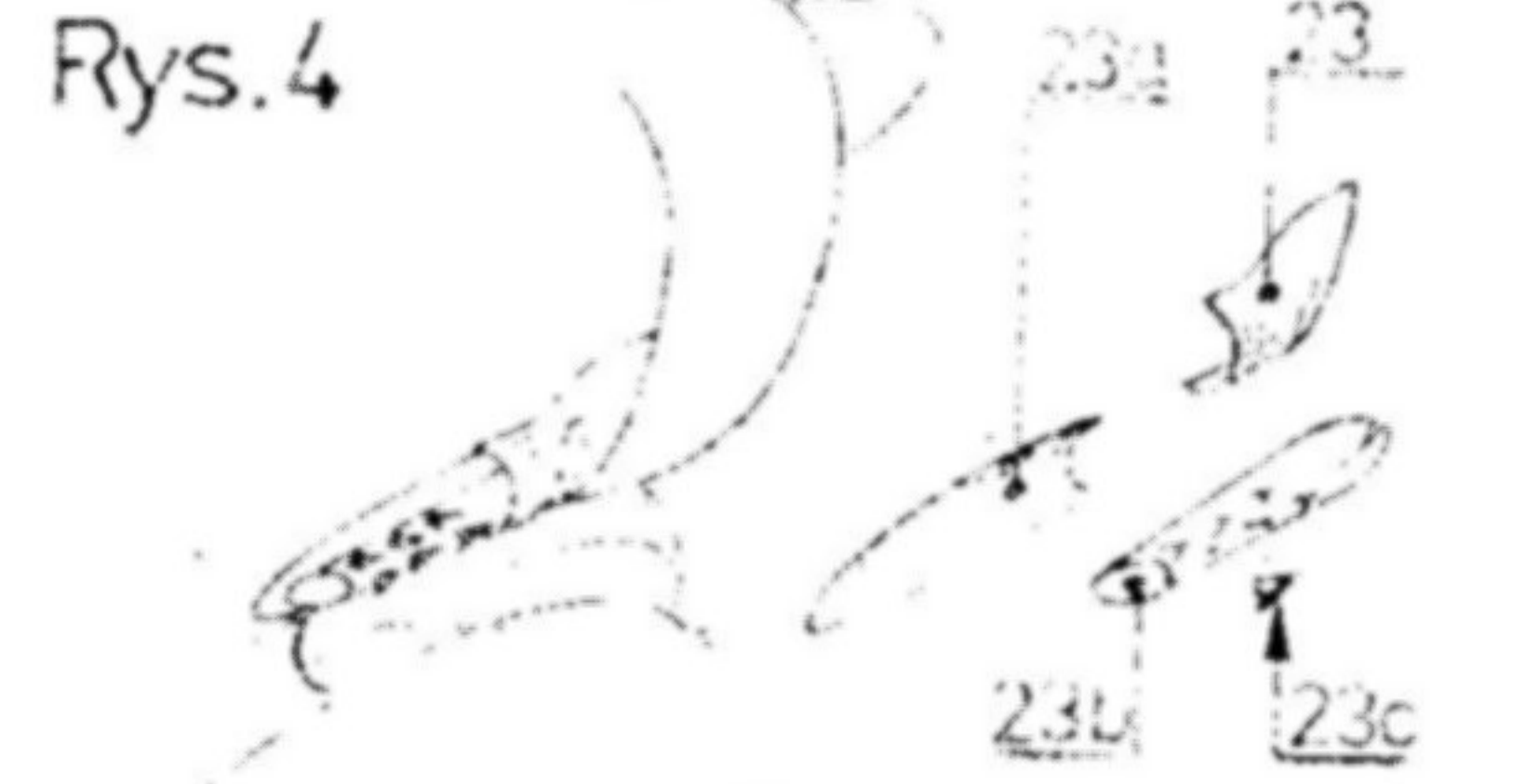
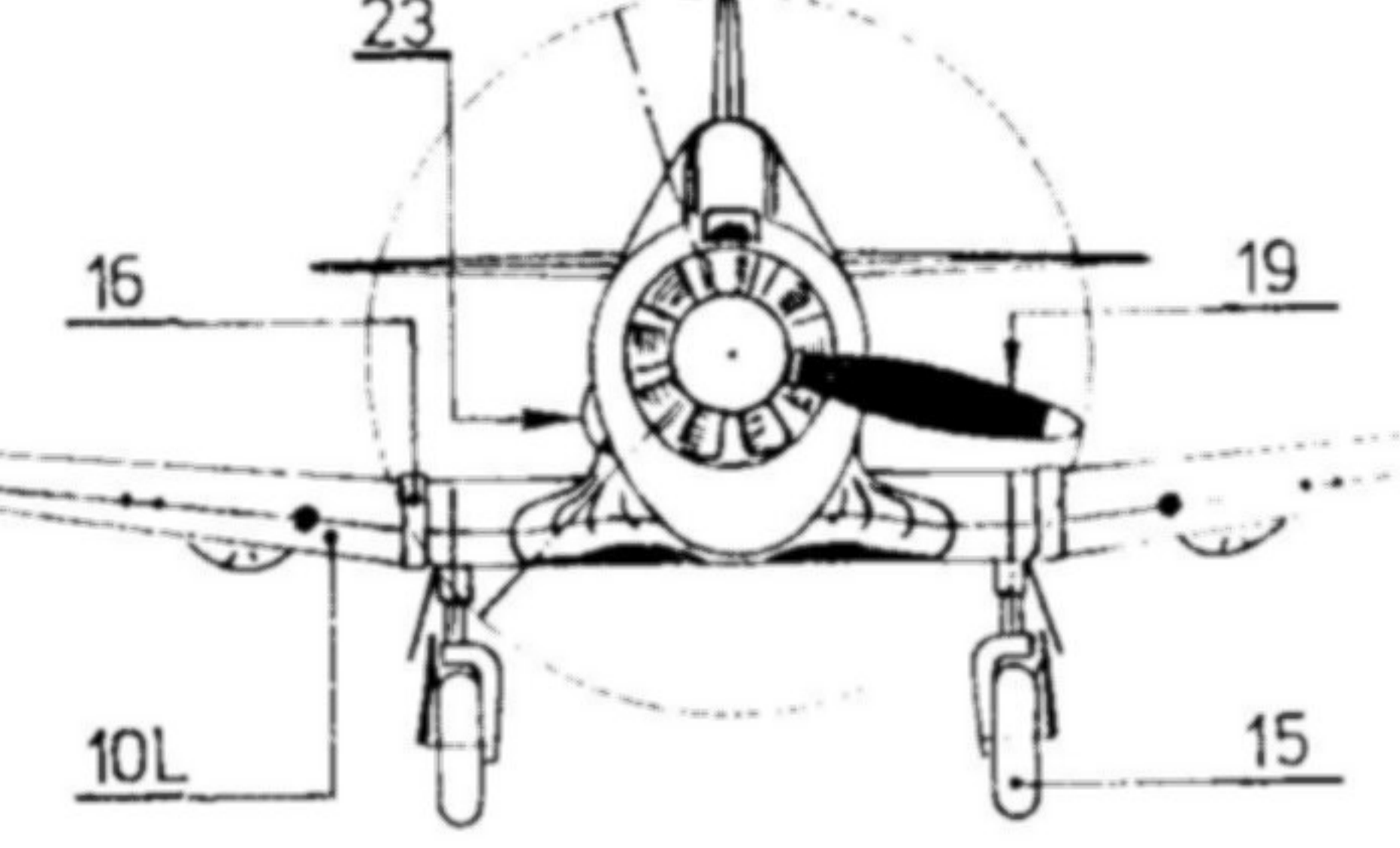
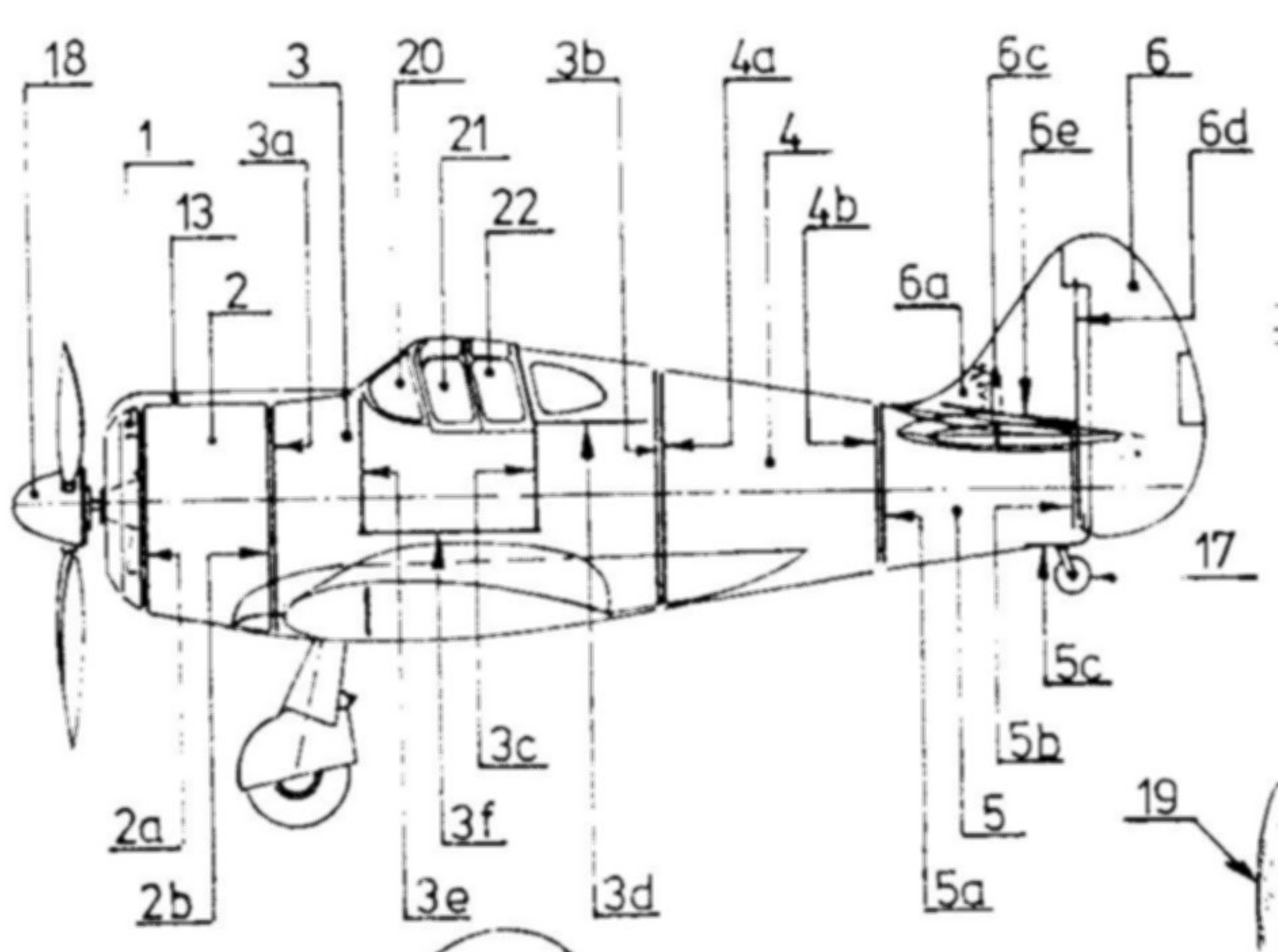

Rys. 6

Uwaga: cz. oznaczone literą L skleamy jak cz. oznaczone literą P.

Budowę modelu rozpoczynamy od sklemania kadłuba. Formujemy cz. 1, 1a, 1b, 2, 3, 4, 5 i wkładamy wręgi 1c, 2a, 2b, 3a, 3b, 3c, 3d, 3e, 3f, 4a, 4b, 5a, 5b, oraz cz. 5c.

Uwaga: część 3 skleamy z wyposażeniem kabiny wykonaną z cz. A, B, C, D, E, F, G, H, J, K, L i drutu S w następującej kolejności; cz. 3 łączymy sklejką /dół/, wkładamy wręgę 3b następnie w obrębie okienek od wewnątrz malujemy szarym kolorem i wyklejamy przezroczystą folią dalej wkładamy cz. F, J i wręgę 3d i kolejno wręgi 3c, 3f, 3e, teraz cz. 3 łączymy sklejką /górną/ i wkładamy wręgę 3a patrz rys. 1. wg rys. 2 skleamy silnik cz. 1a, 1e, 1f i 1g oraz wg rys. 4 rurę wydechową cz. 23, 23a, 23b, 23c. przyklejamy do kadłuba statecznik kier. cz. 6, 6a, 6b, 6c i żeber 6d, 6e. W cz. 5 wycinamy otwory pod dźwigar 9b, skleamy stateczniki wys. cz. 9P, 9aP nasuwamy na dźwigar i przyklejamy do kadłuba.

Centropłata: wykonujemy z cz. 7, 7d dźwigara 7a żeber 7b i 7c i przyklejamy do kadłuba. Gondole podwozia cz. 8, 8a, 8b, 8c, 8d przyklejamy do kadłuba i centropłata.

Uwaga: odpowiednie uformowanie gondoli przedstawiono na rys. 3. Przyklejamy osłony 11P i 11L. Płatek: cz. 10P, 10d formujemy i oklejamy dźwigar 10aP i żebra 10bP i 10cP przyklejamy do centropłata 7 i oklejamy listwą cz. 16 podwozie wyk. z cz. 15, 15a, 15b, 15c, 15dP, 15eP, 15f i drutu X wg rys. 5 oraz kółko ogonowe cz. 17, 17a, 17b, 17c i drutu Y wg rys. 6.

Wiadrochron: cz. 20, 21, 22 wycinamy okienka, malujemy szarym kolorem, następnie oklejamy przezroczystą folią całość przyklejamy do kadłuba. Kołpak skleamy z cz. 18, 18a i 18b oraz łopaty śmigieł cz. 19, 19a całość osadzamy na szpilce i mocujemy do silnika wg rys. 2. Końcową fazą budowy jest wkładanie działek cz. 24 i 24a, rurki pilota Z i przyklejenie osłon pod skrzydła cz. 14.

Oprac. graf. i opis - T. Grzelczak - Łódź
SWW 22 2825-99
Dz. U. Nr 44/89

101

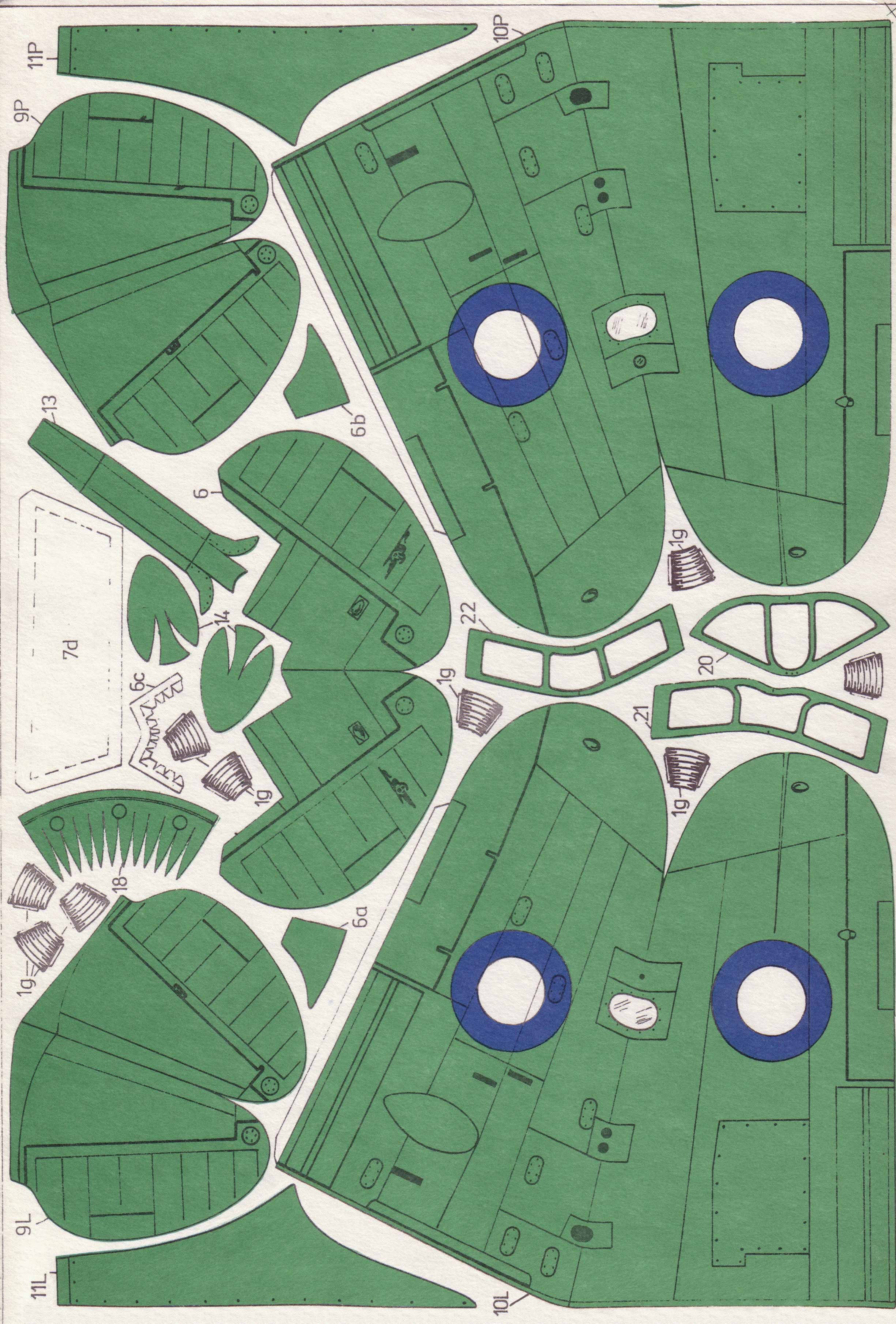

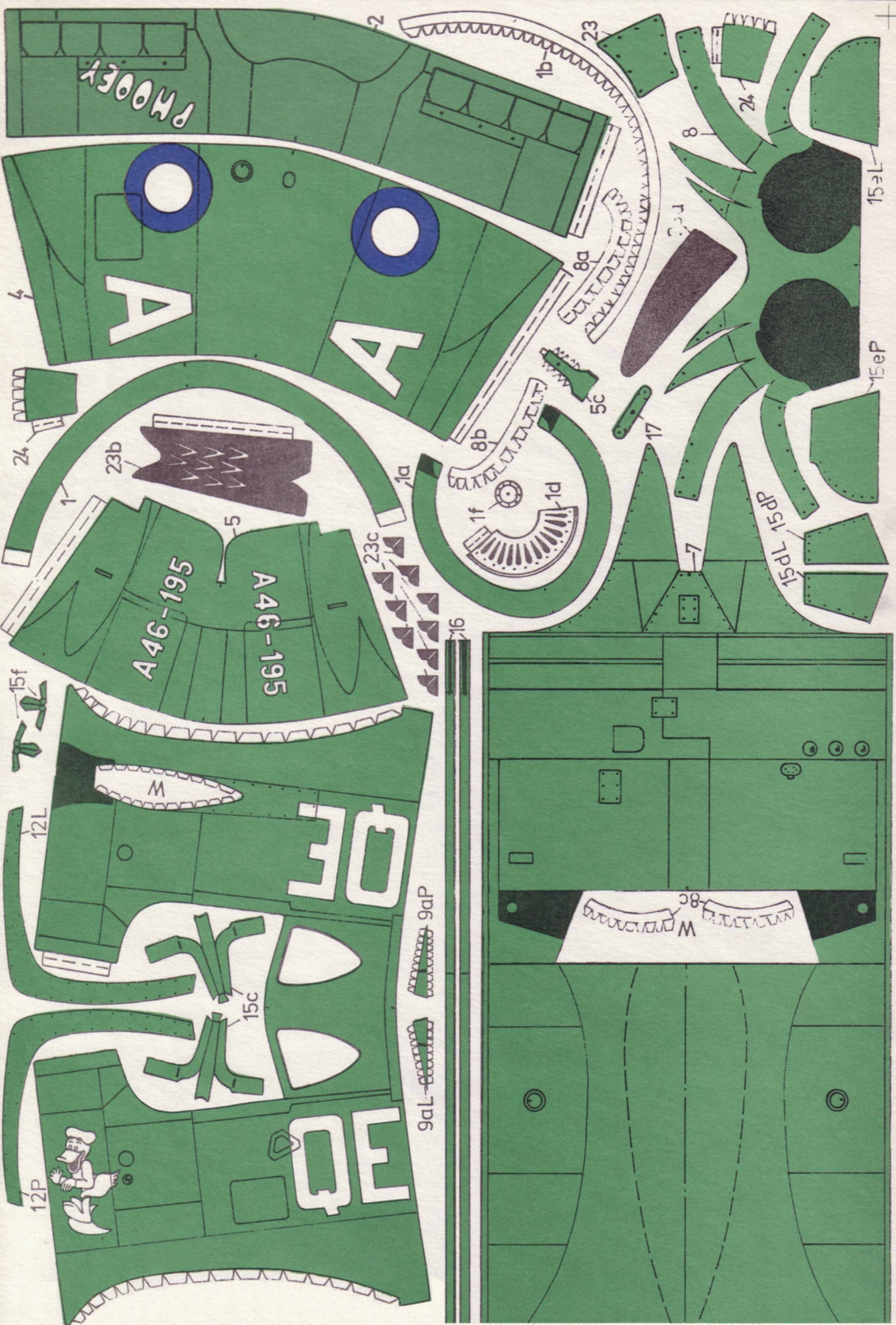

PHOOPY

A

A

A46-195

A46-195

OFF

OFF

