

JOIN MB1.2 USING
JOIN STRIP 1

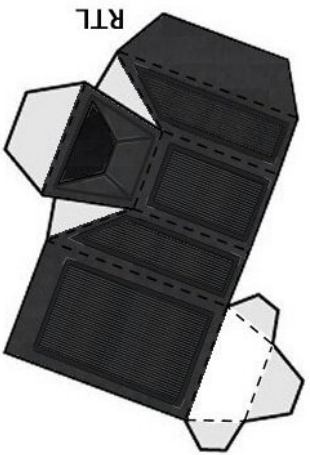

PODTR



PODTL

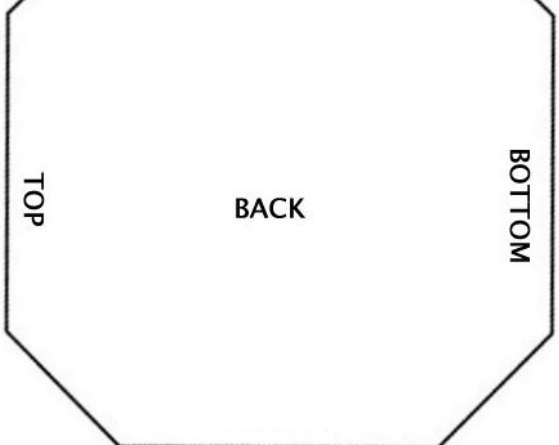
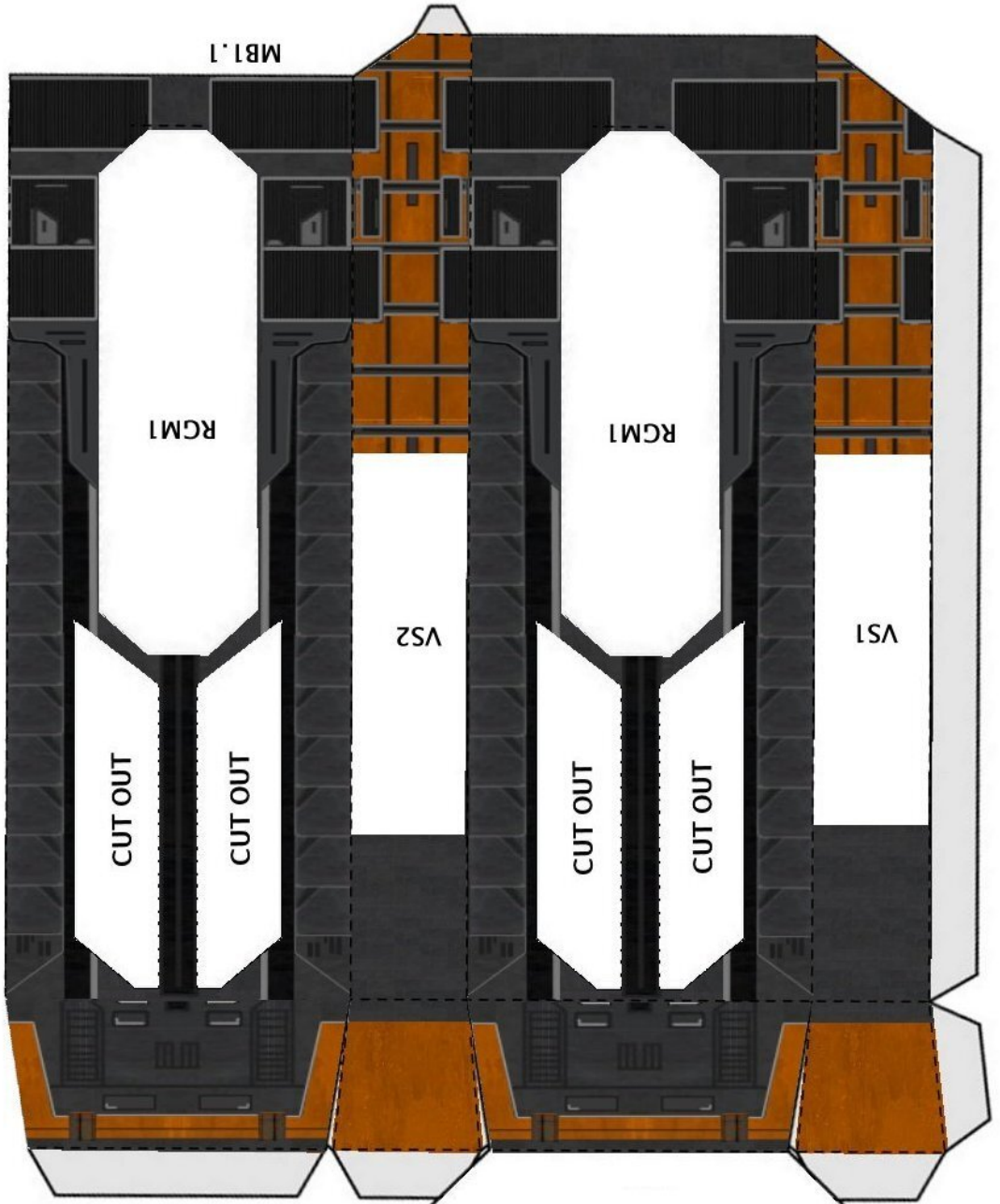

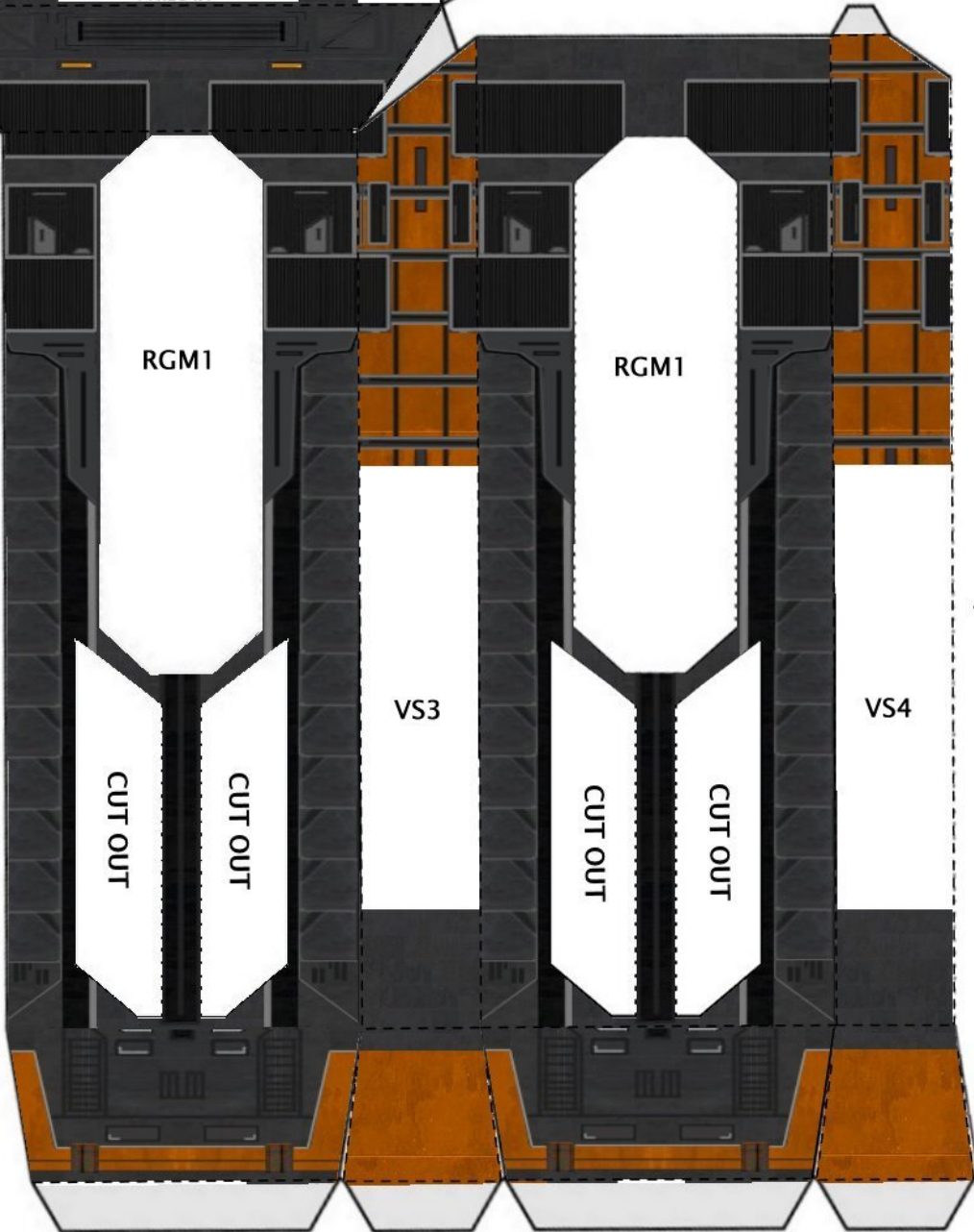
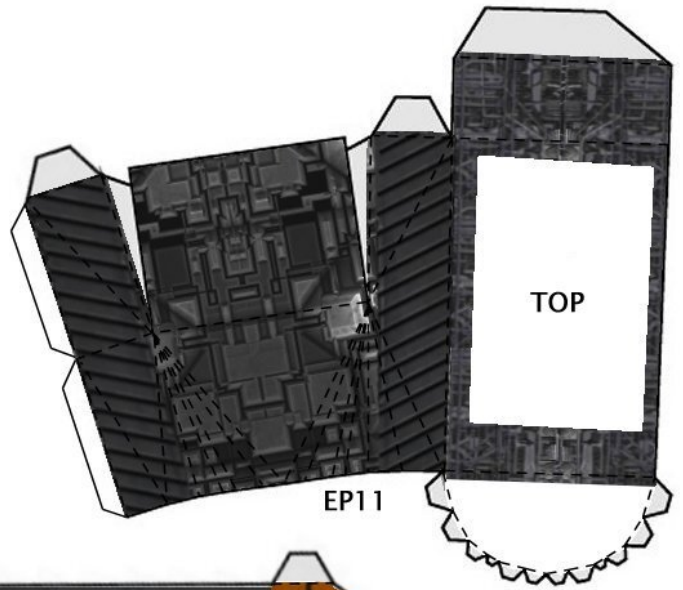
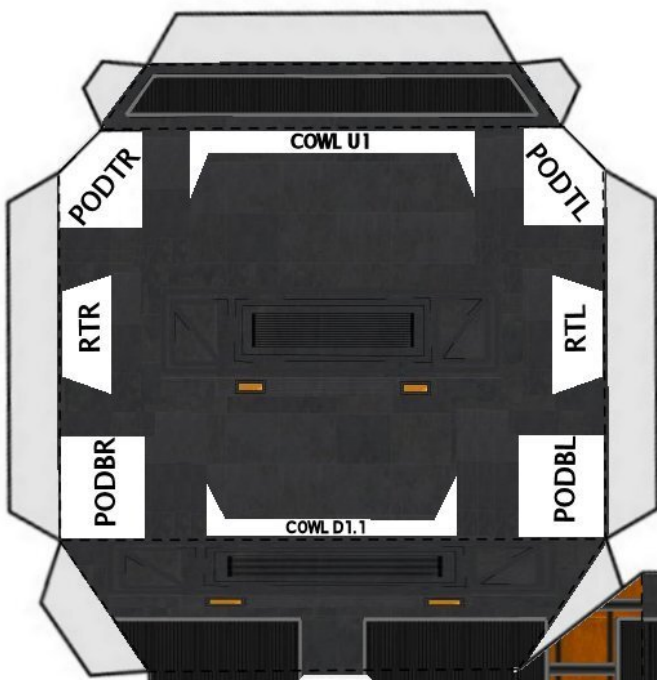

←
JOIN MB1.1 USING
JOIN STRIP 1

MB1.2

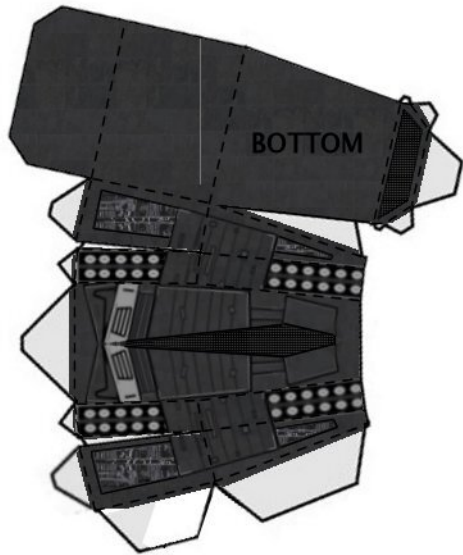

EP1

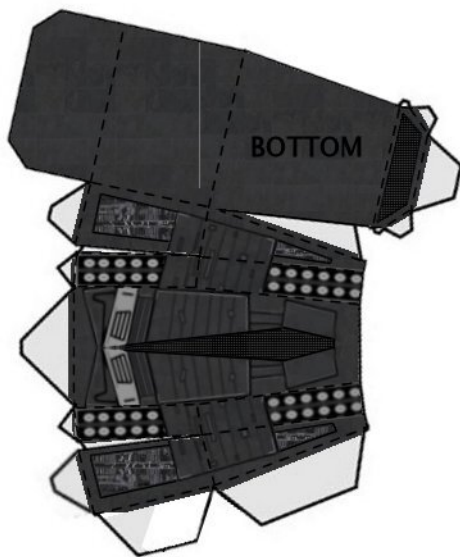

EP1

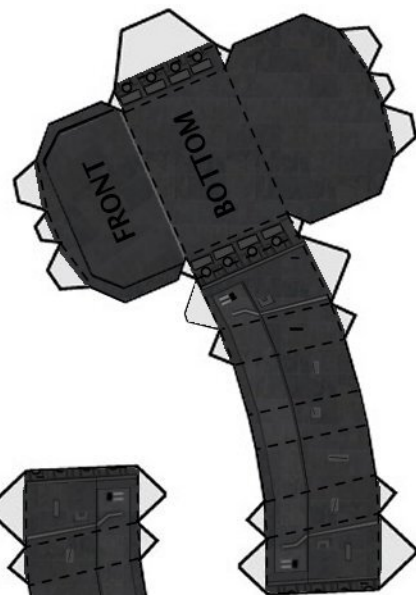

EP2

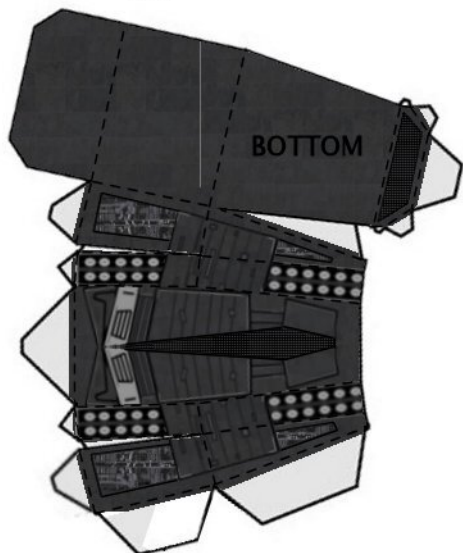

EP1

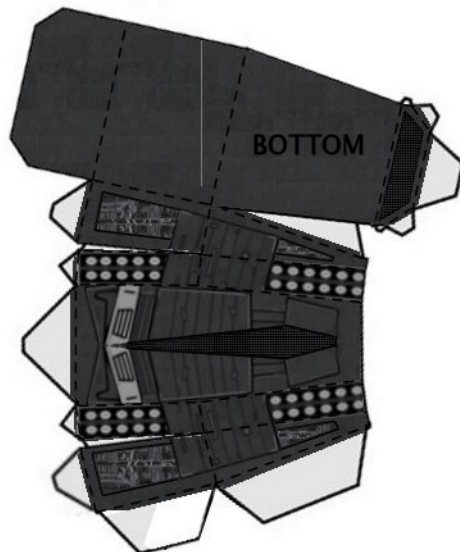

EP1

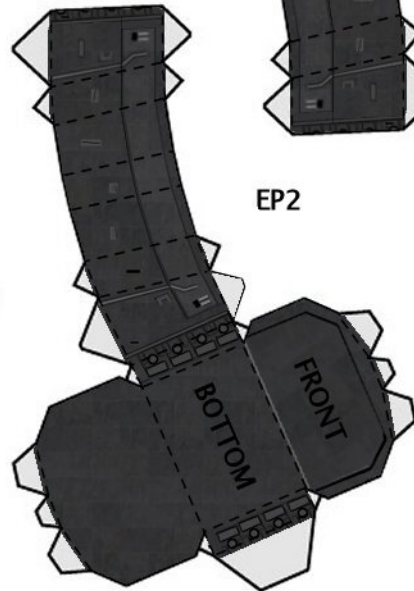

EP2

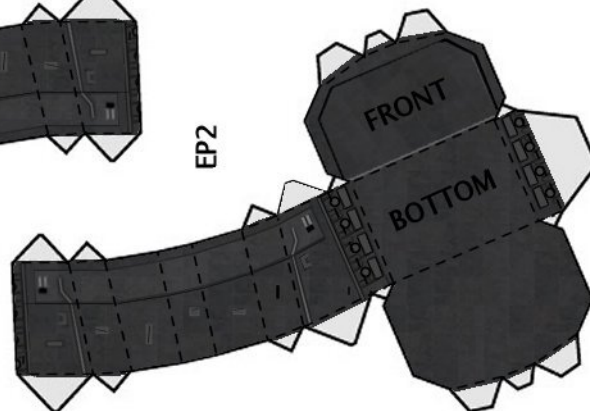

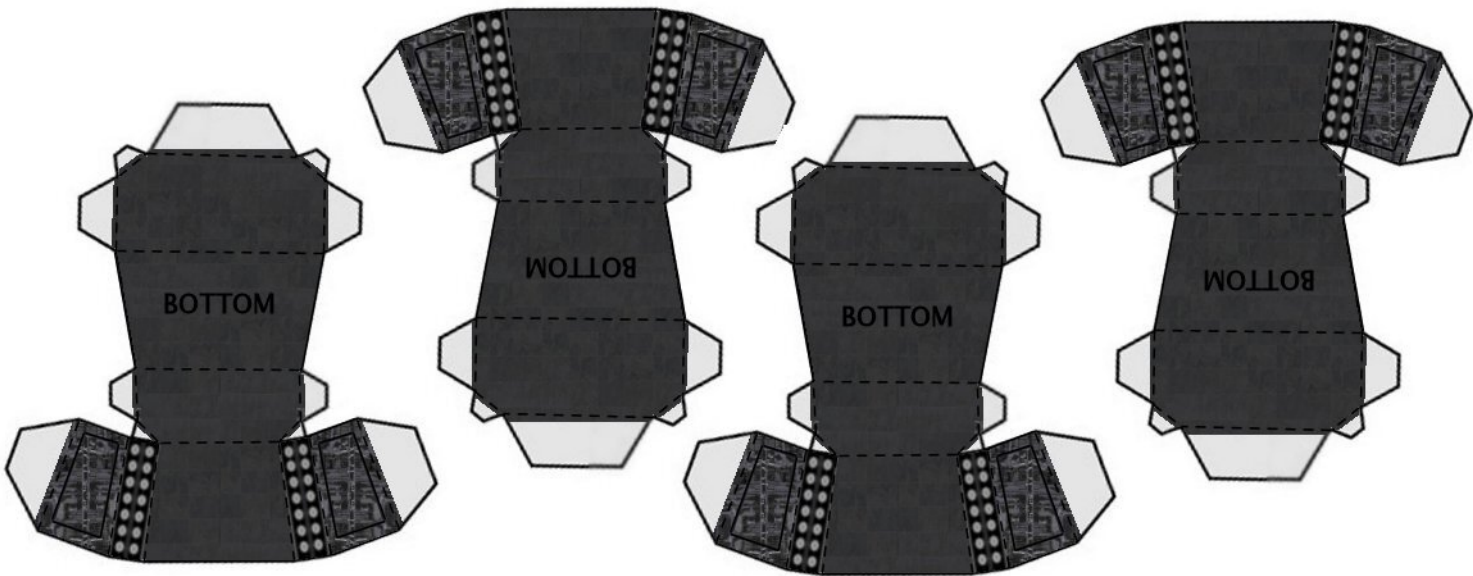
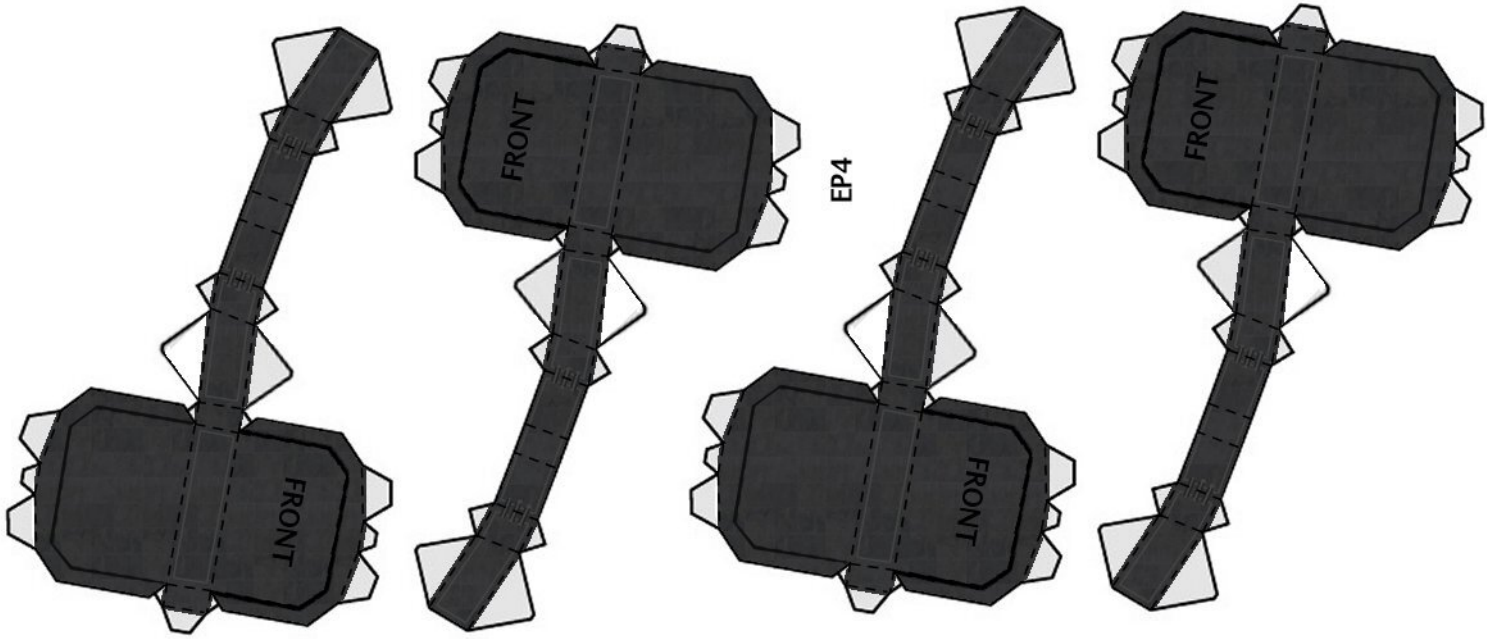
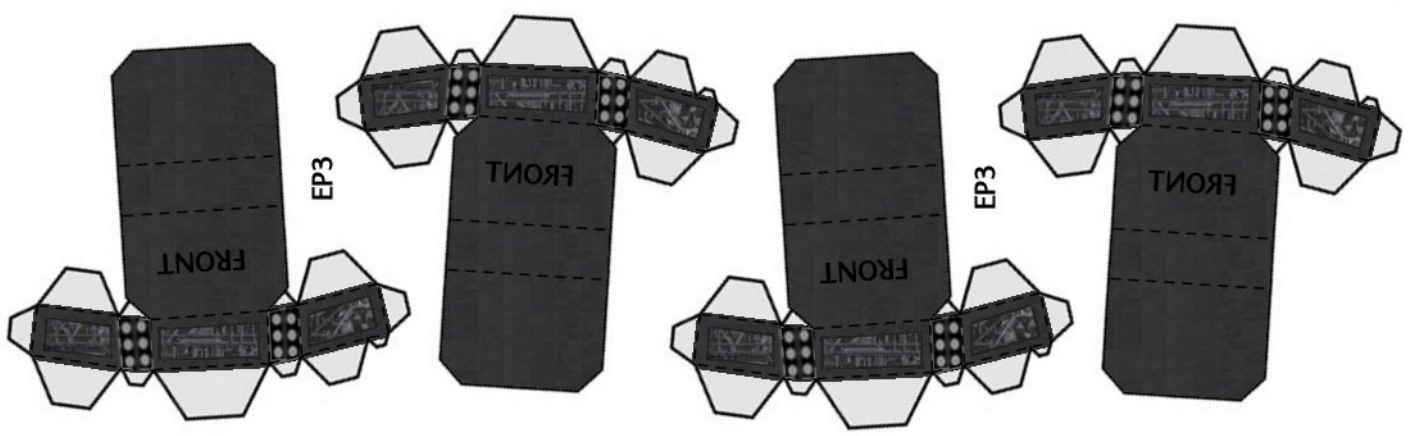

EP6

EP6

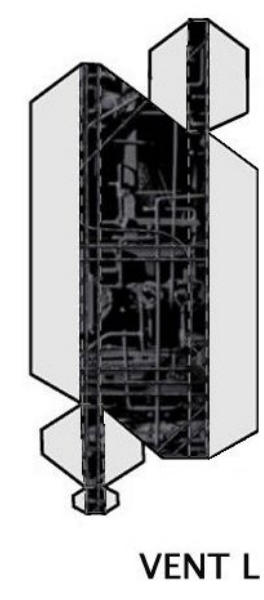
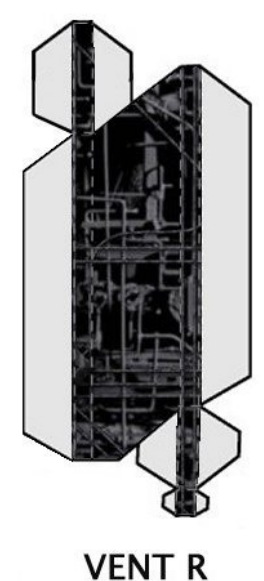
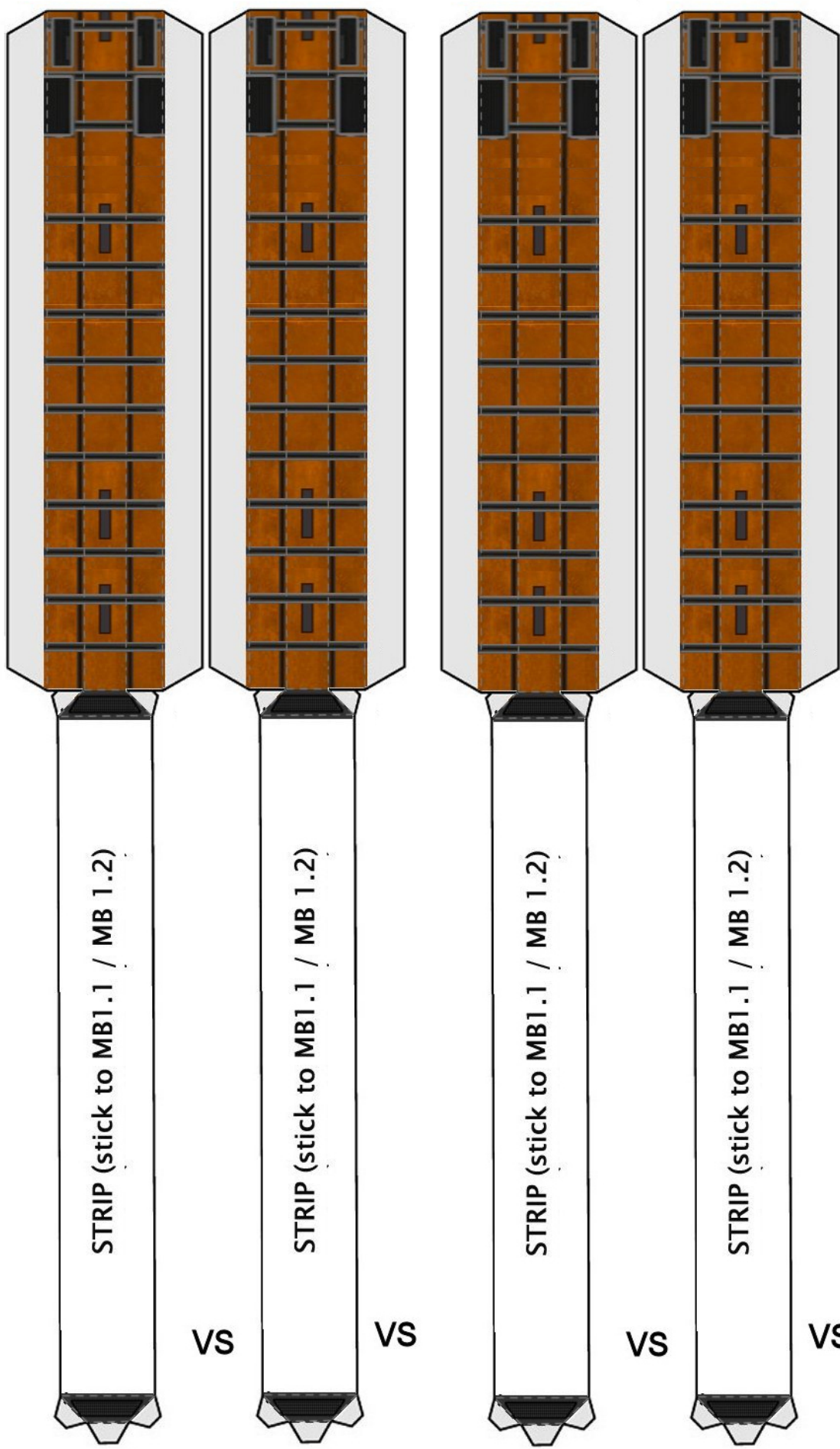



VENT 2

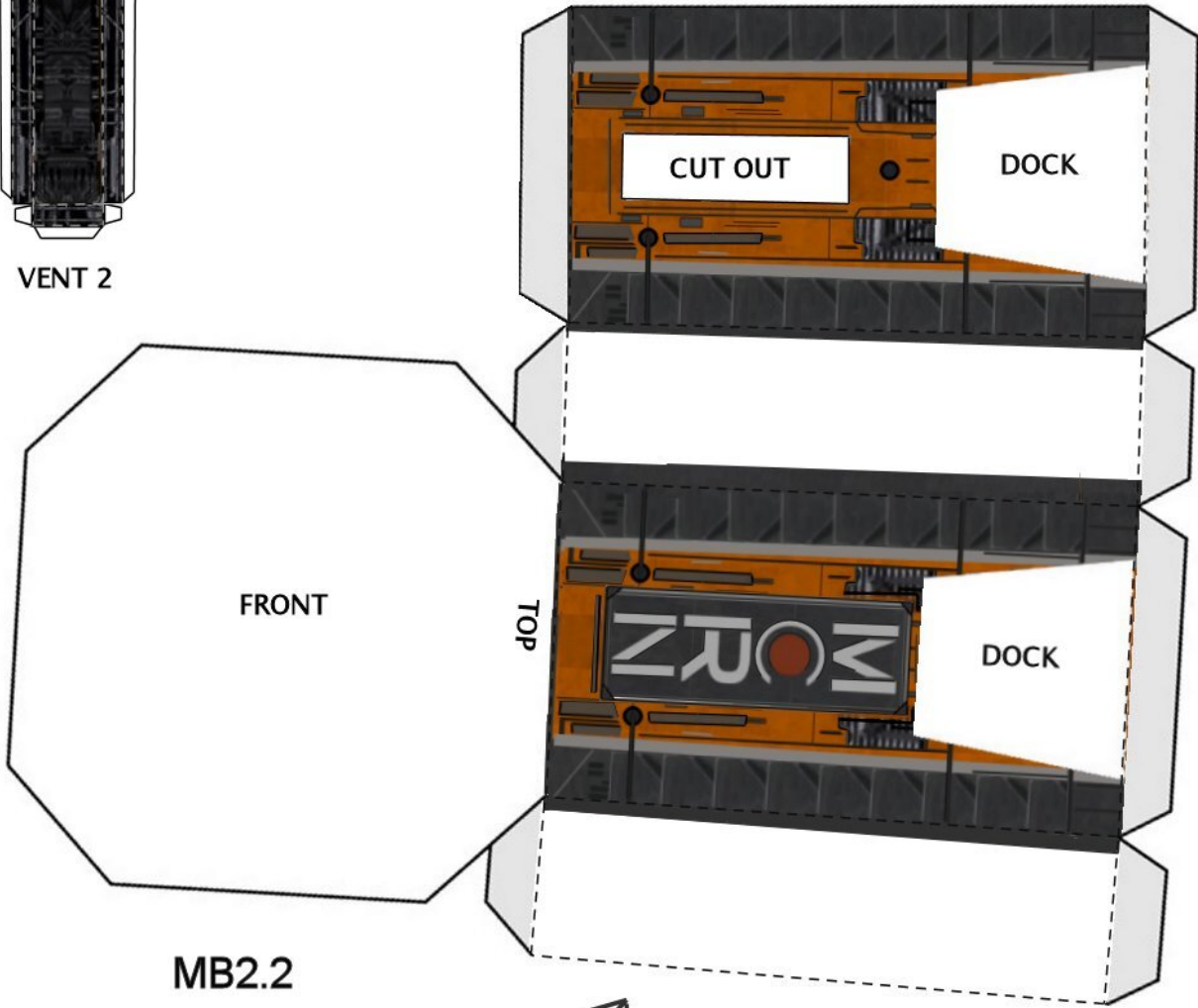

MB2.2

JOIN M2.1 HERE

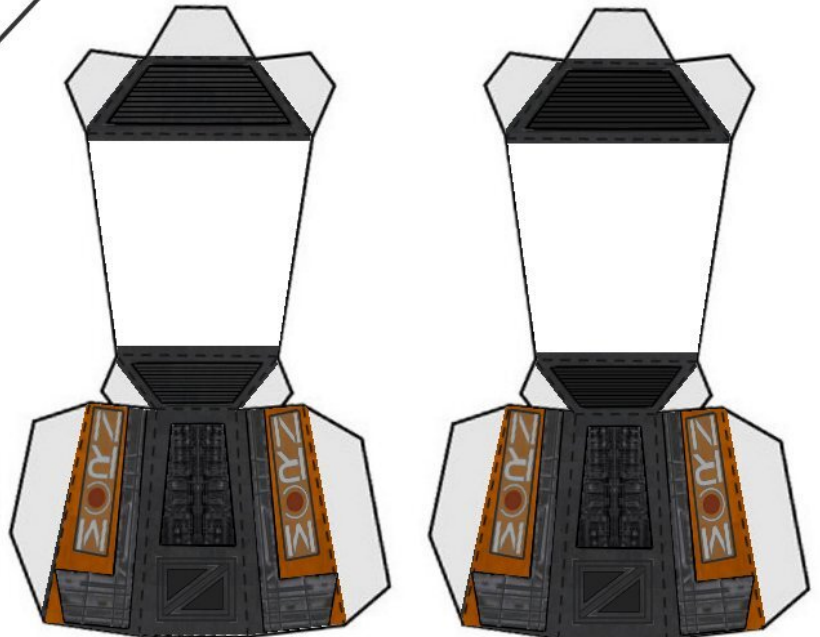

DOCK

DOCK



DOCK



DOCK

JOIN MB2.2
USING JOIN STRIP 2

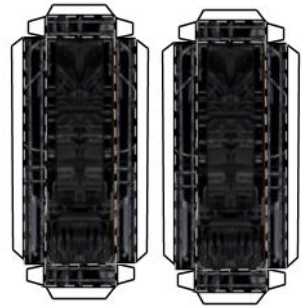
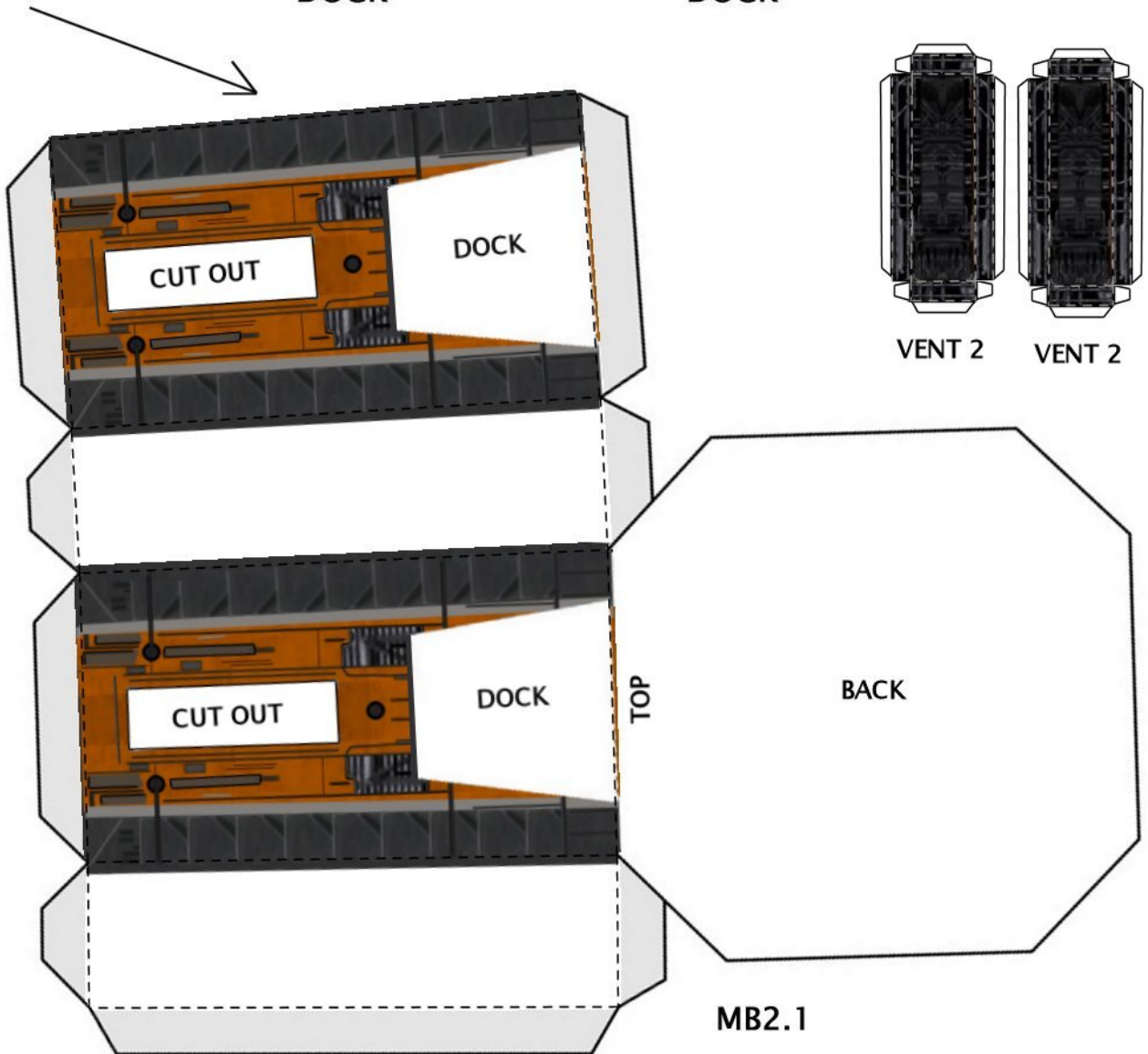

VENT 2

VENT 2

MB2.1

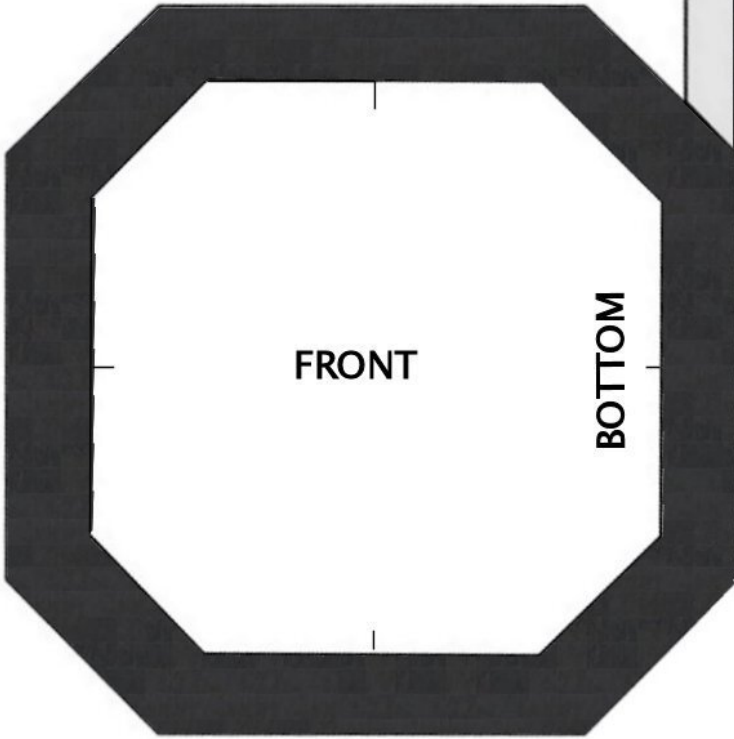
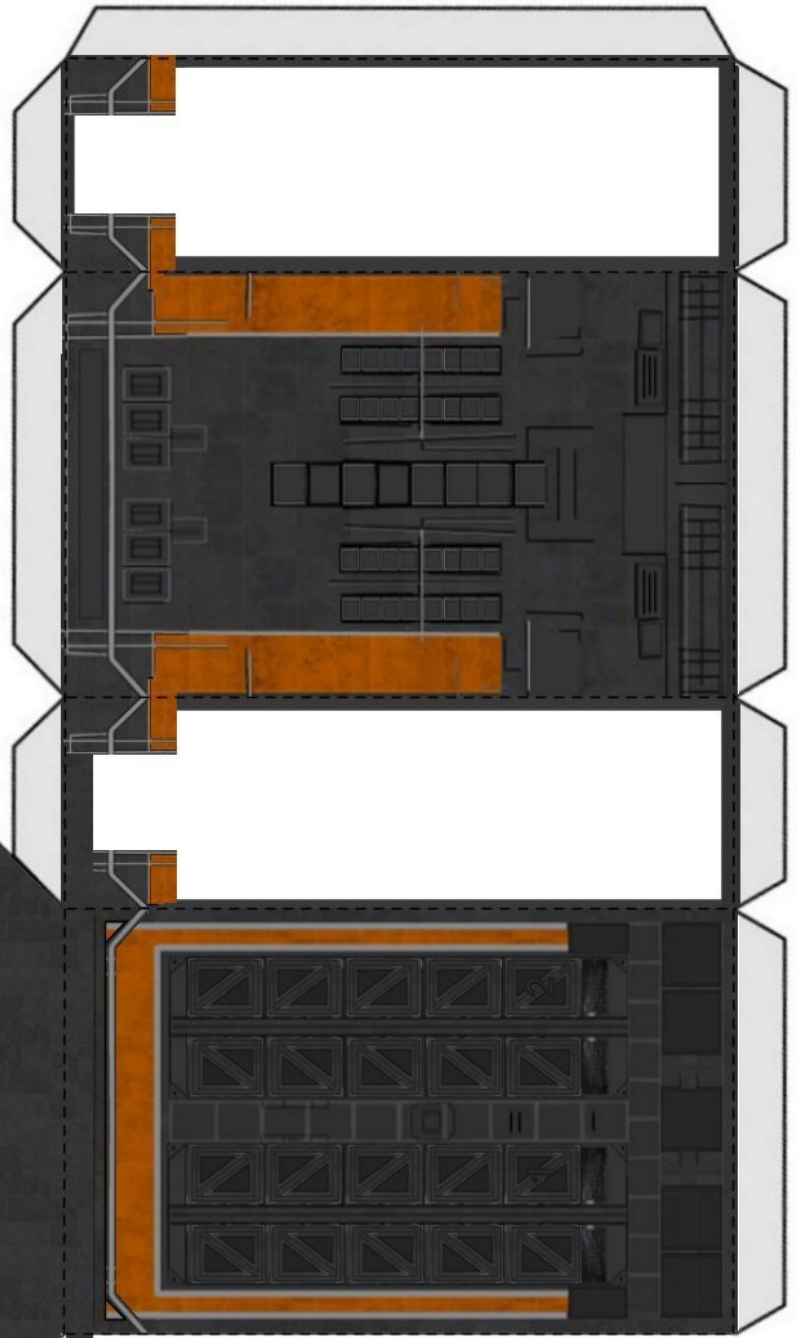
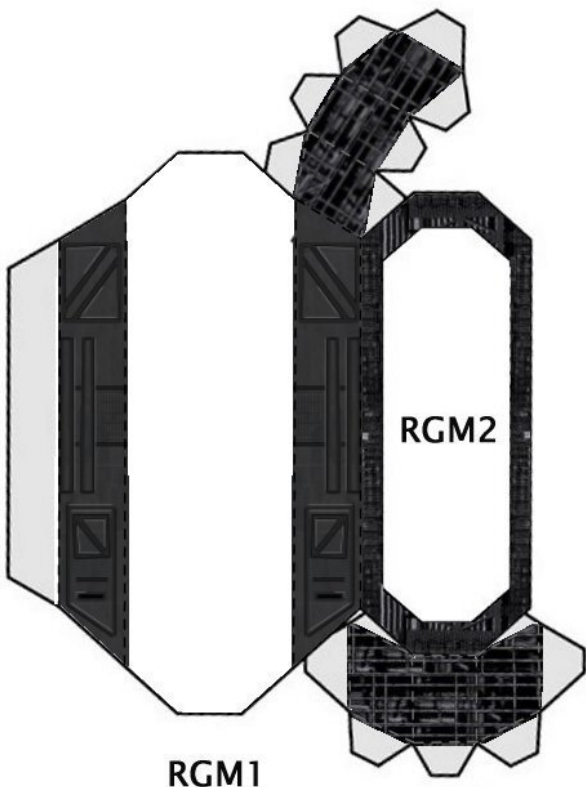

JOIN MB3.2
USING JOIN STRIP 3



An upward-pointing arrow is located below the text, pointing towards the MB3.1 component in the diagram above.

JOIN MB3.1 HERE

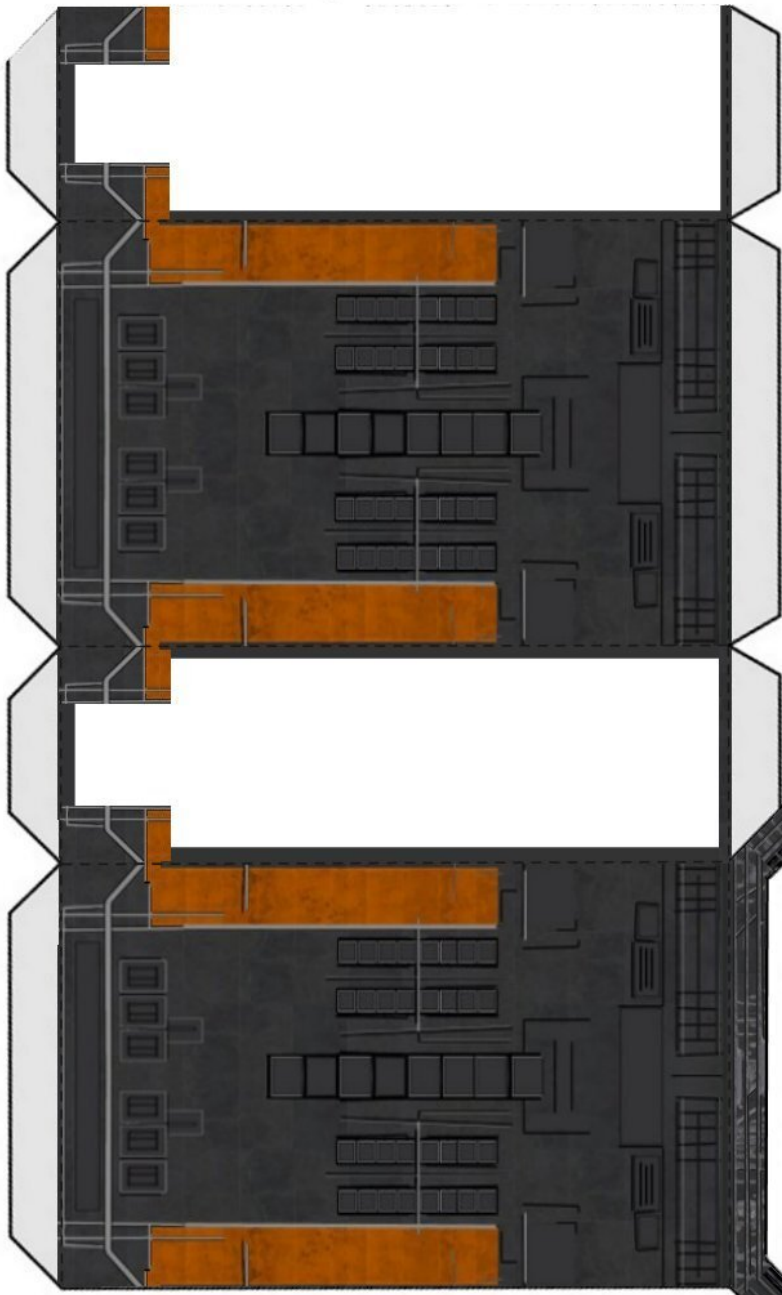

MB3.2

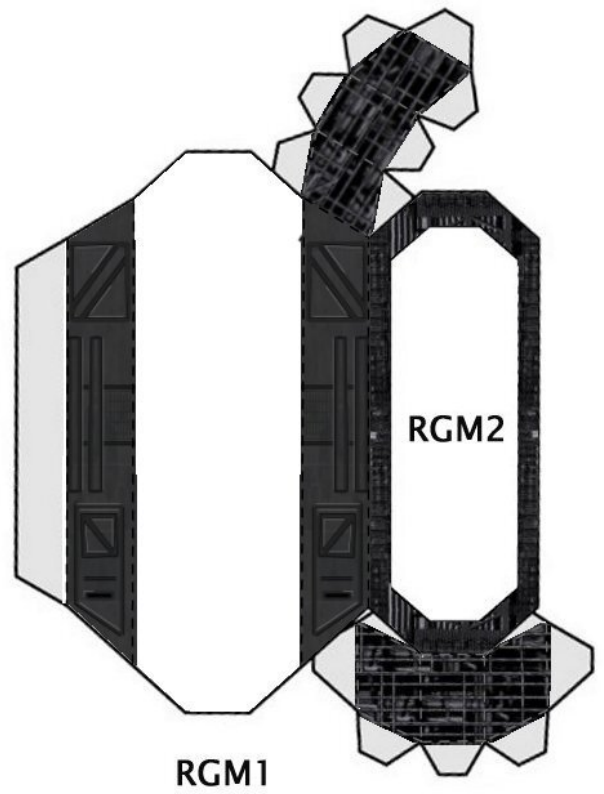

RGM1

RGM2

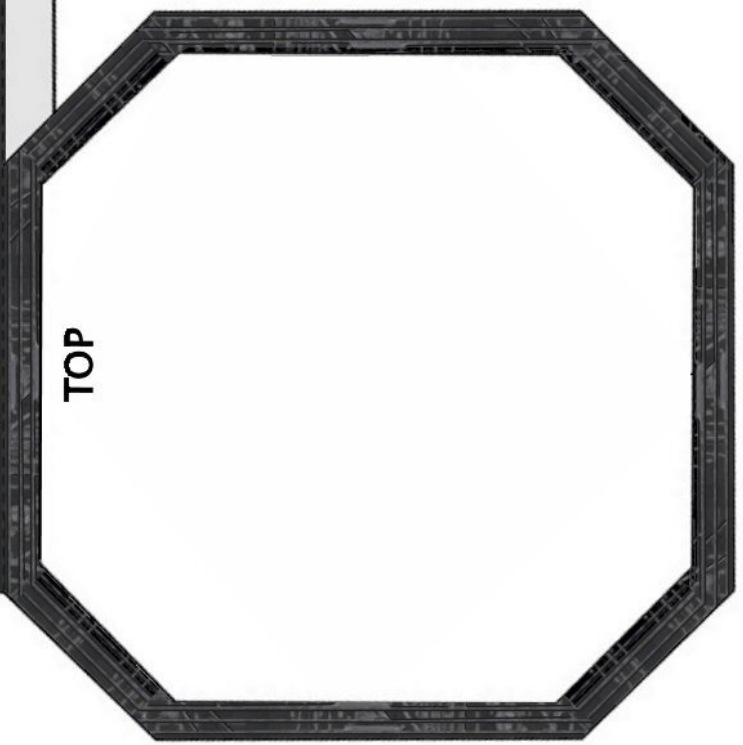

TOP

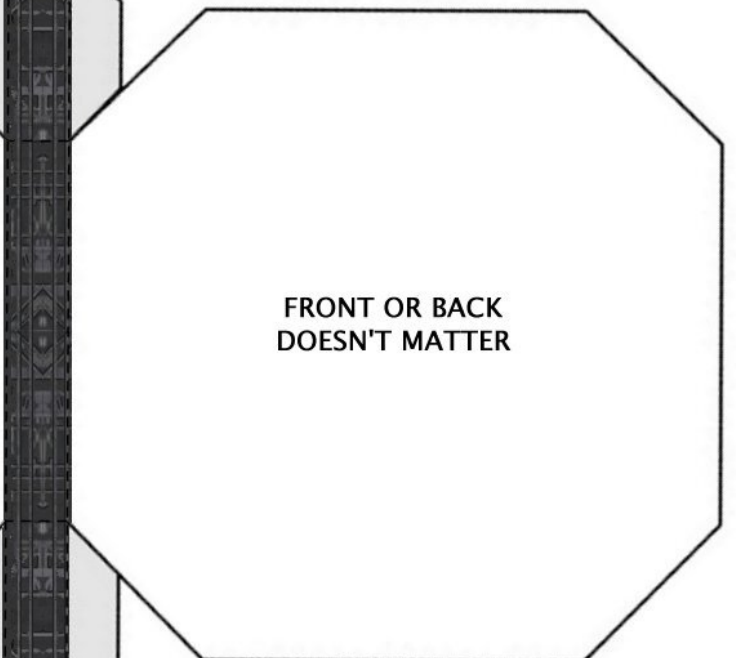
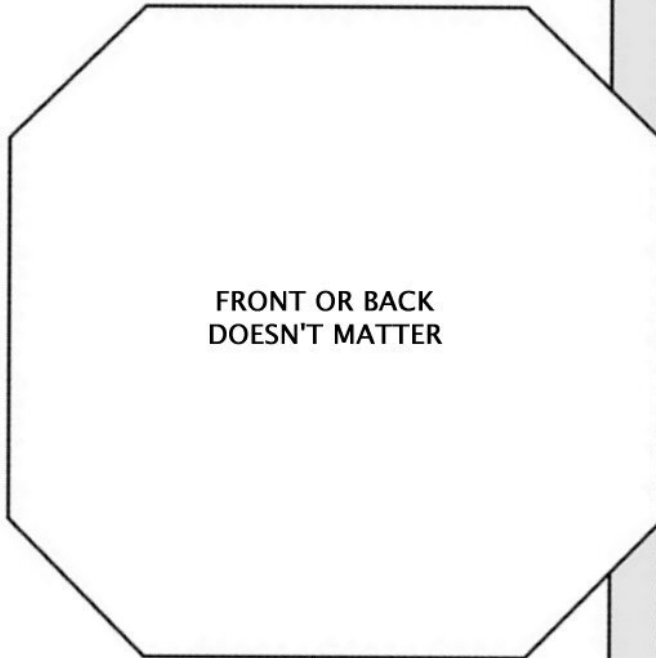
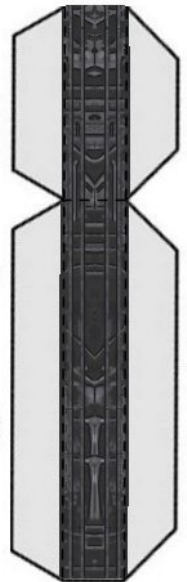
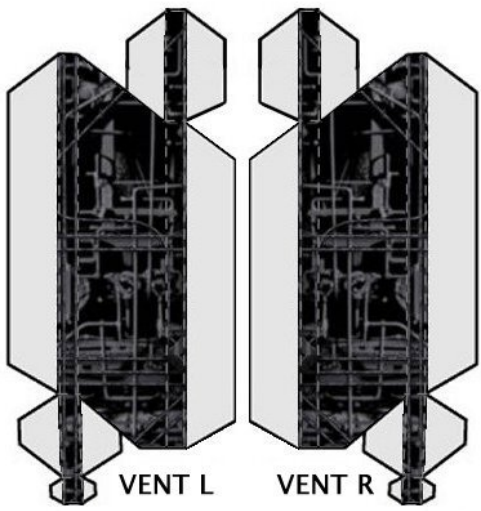

MB4.1

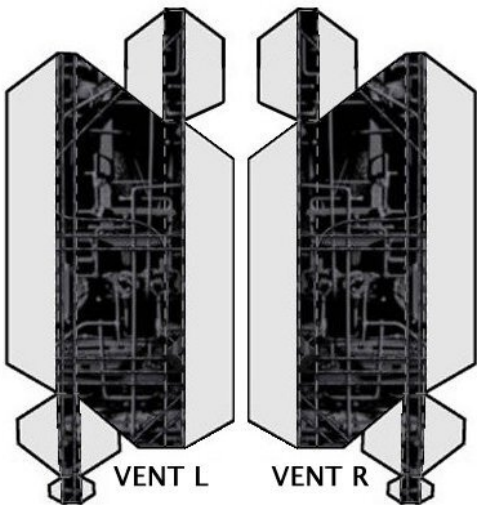

↑
JOIN MB4.2
HERE

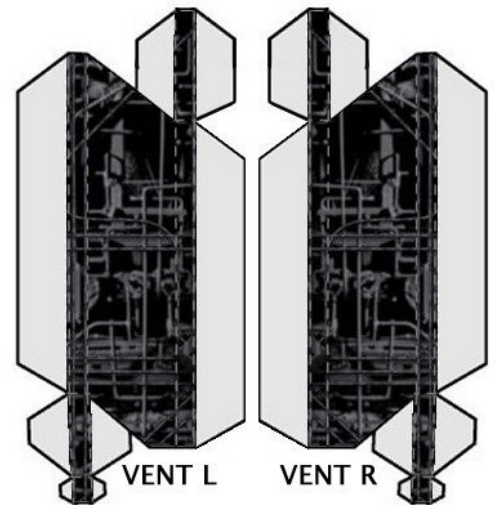

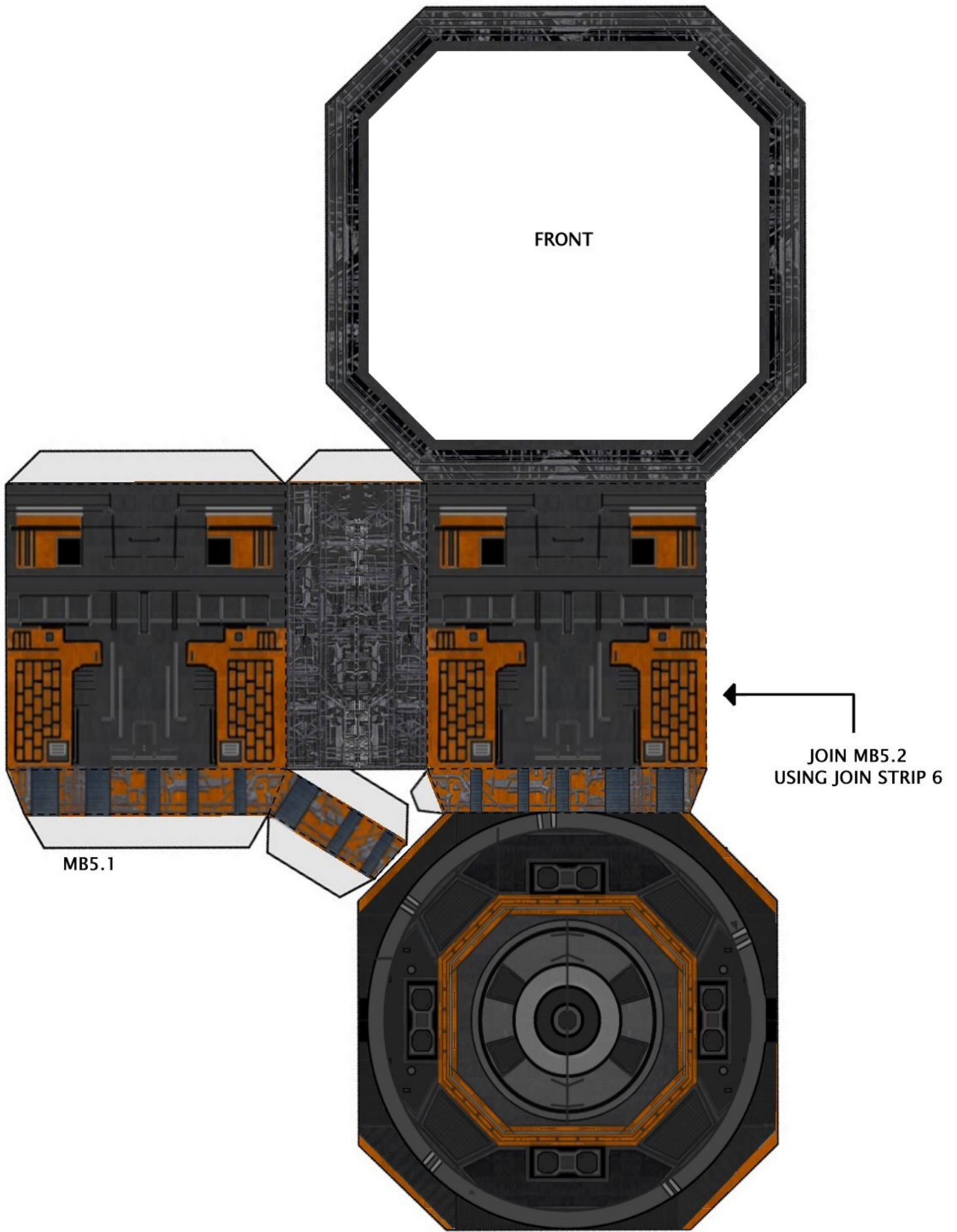

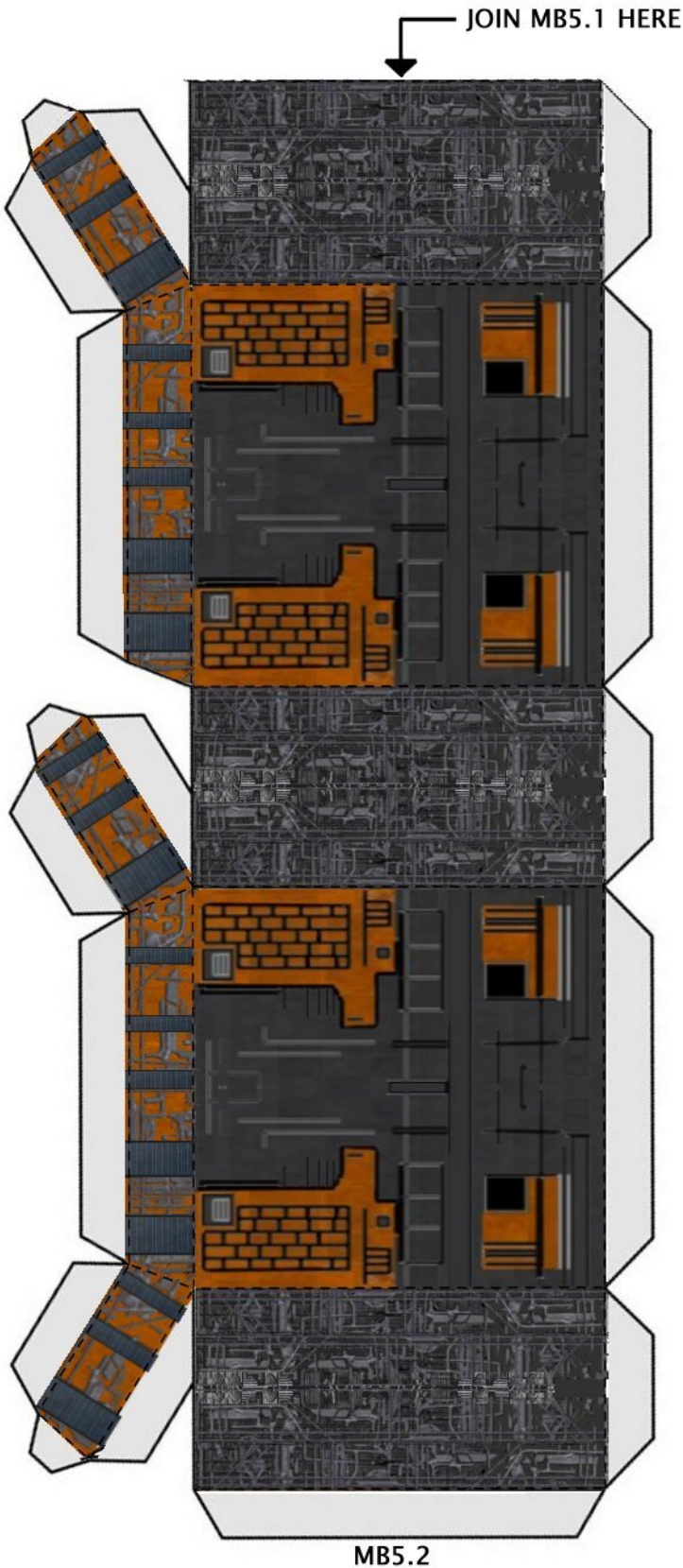

RGCOVER



RGCOVER

RGM2

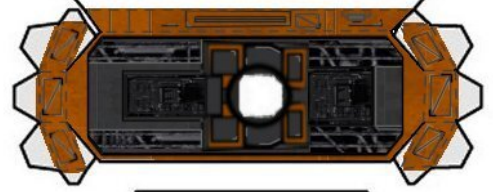

RGM2



RGM2

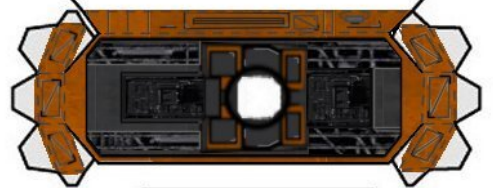

RGM2



RGLANK

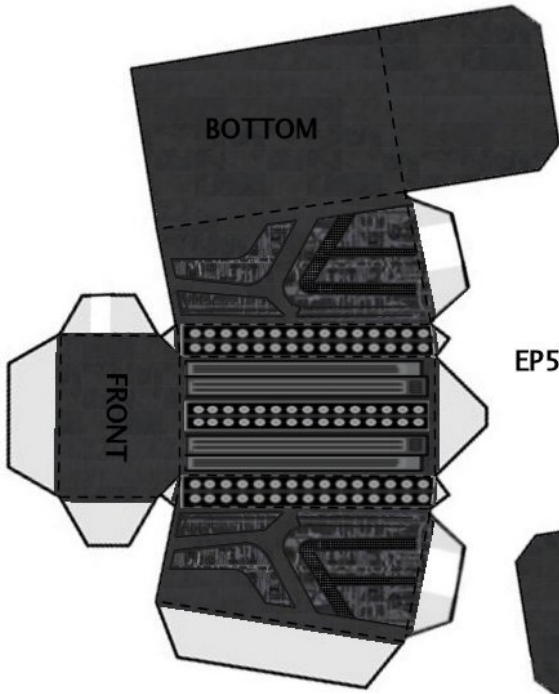

EP5

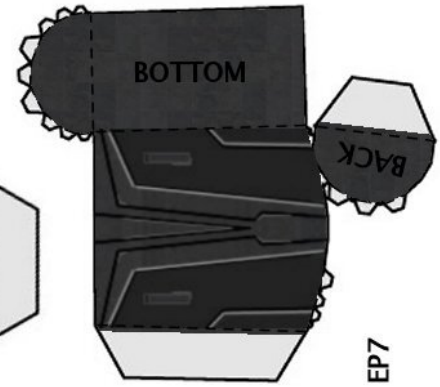
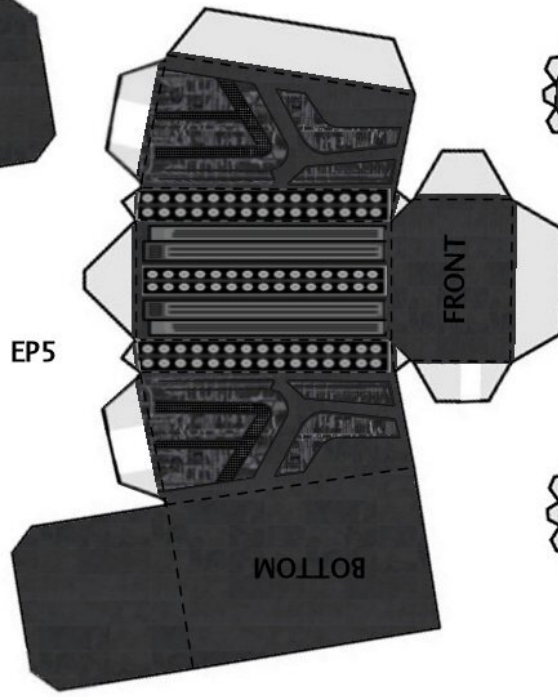

EP7

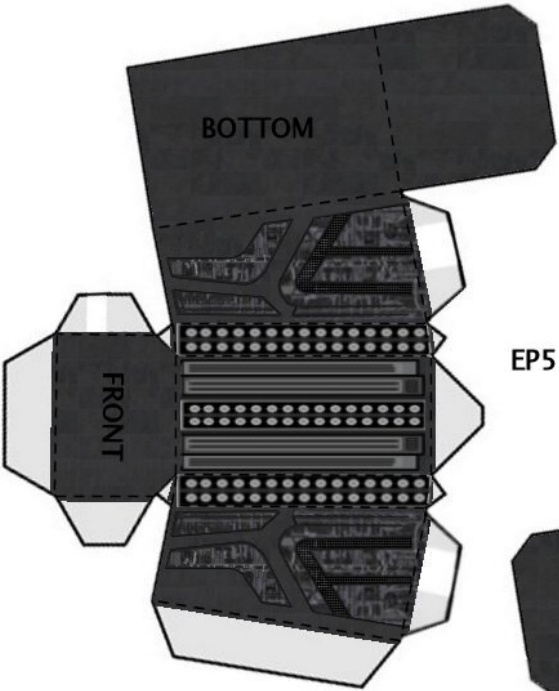
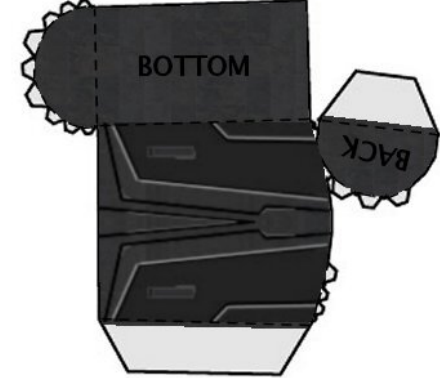

EP5

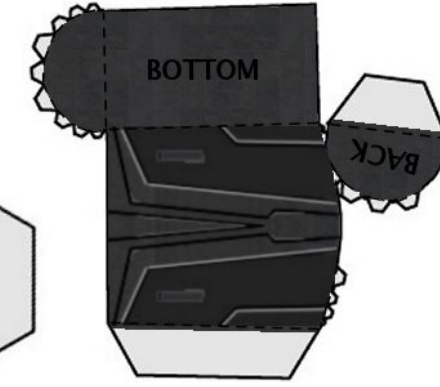
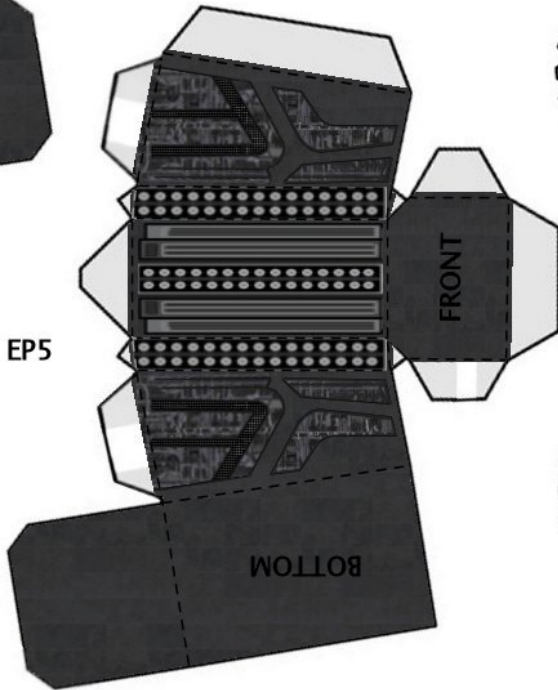

EP7

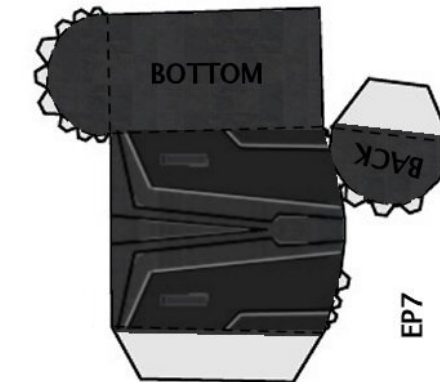

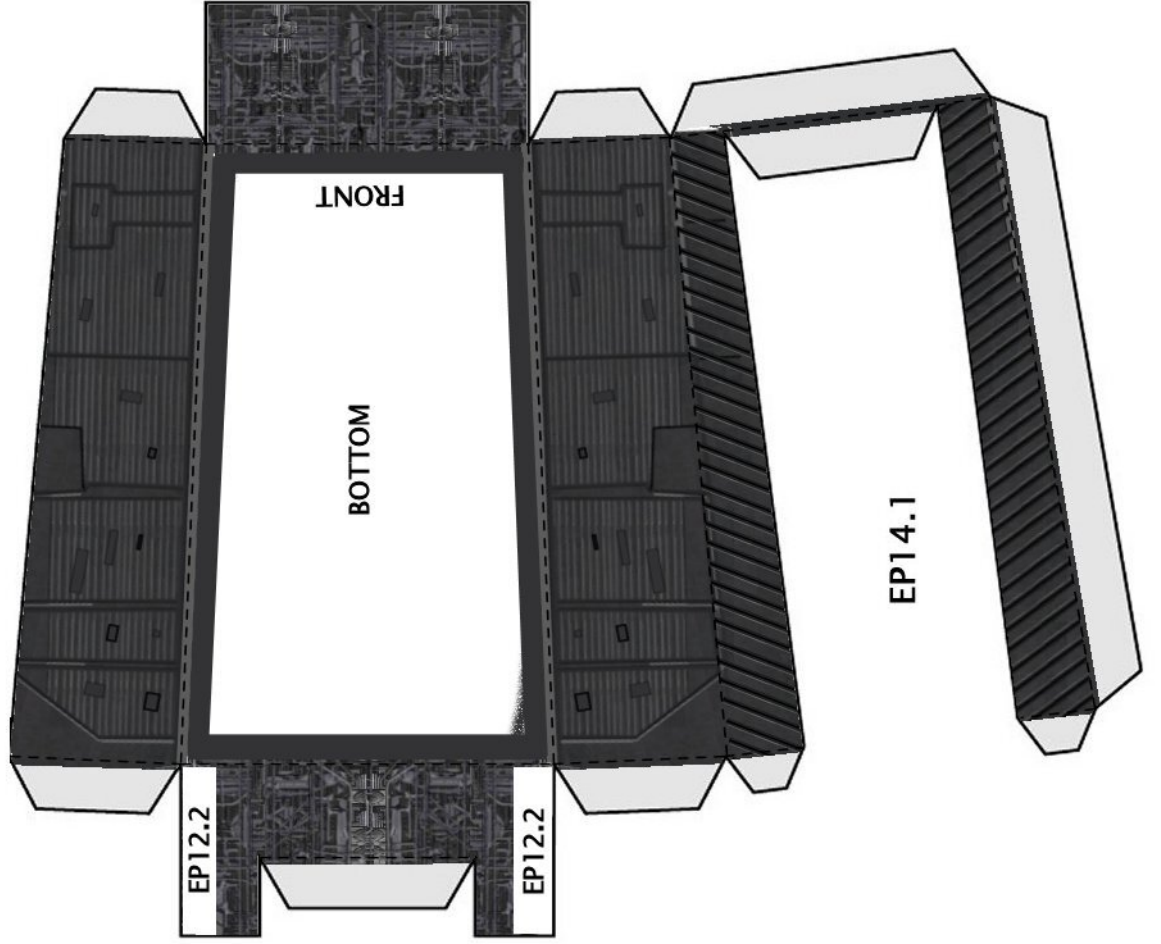
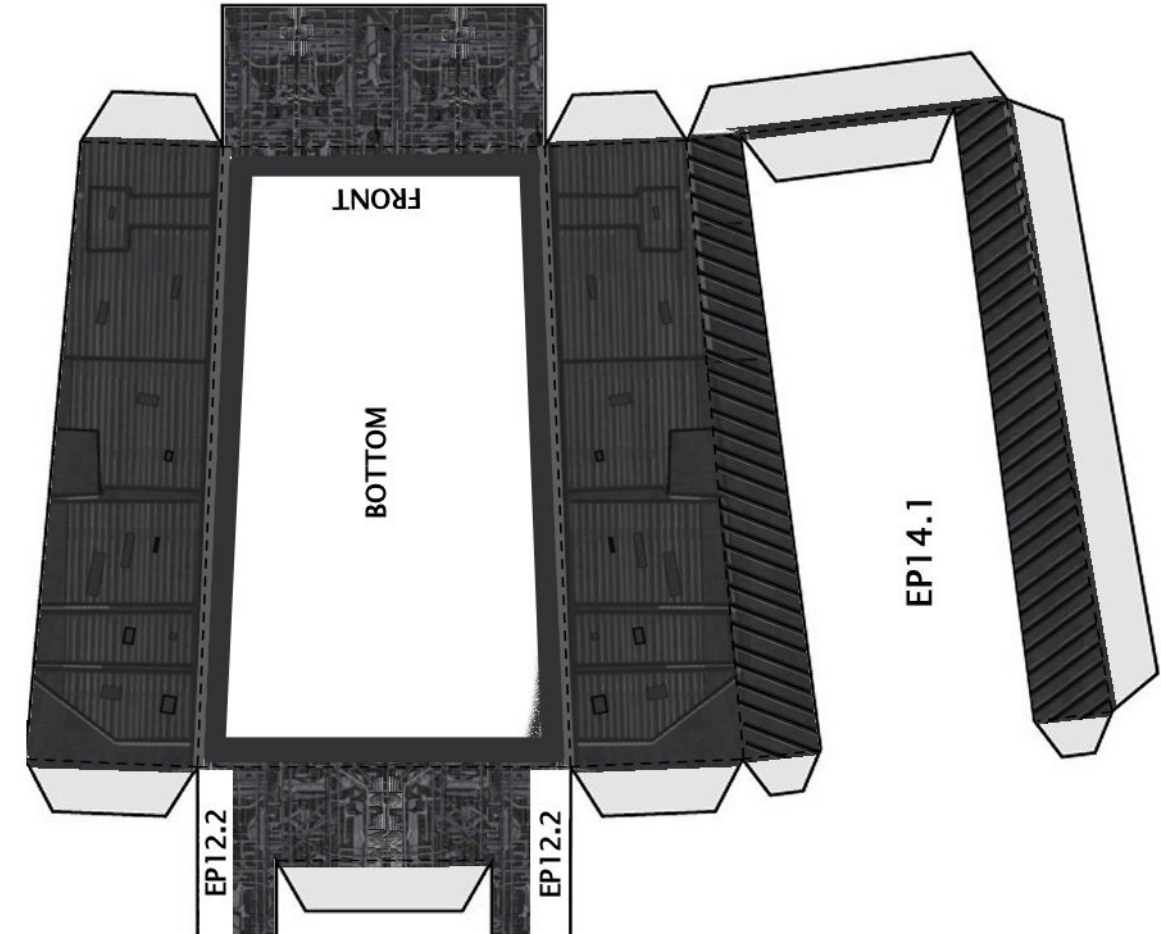

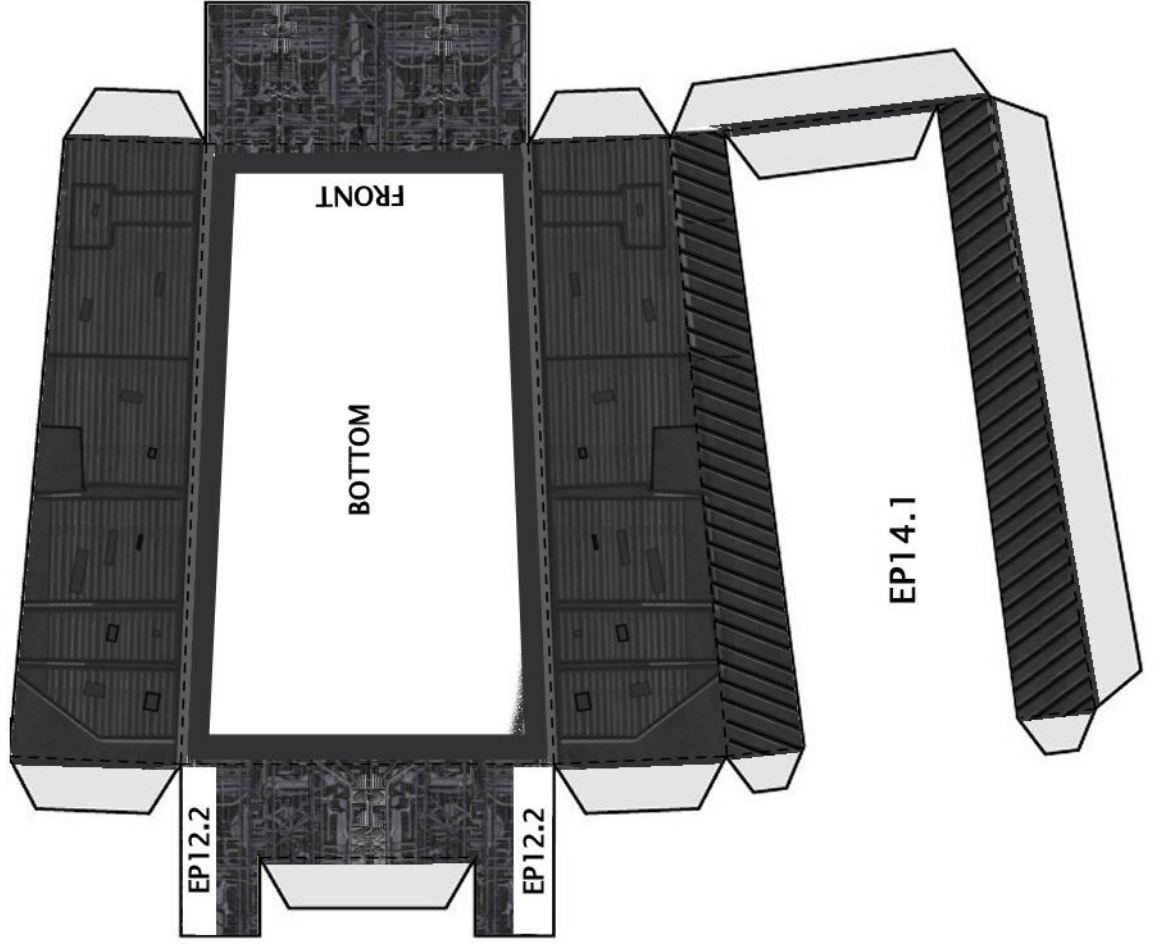
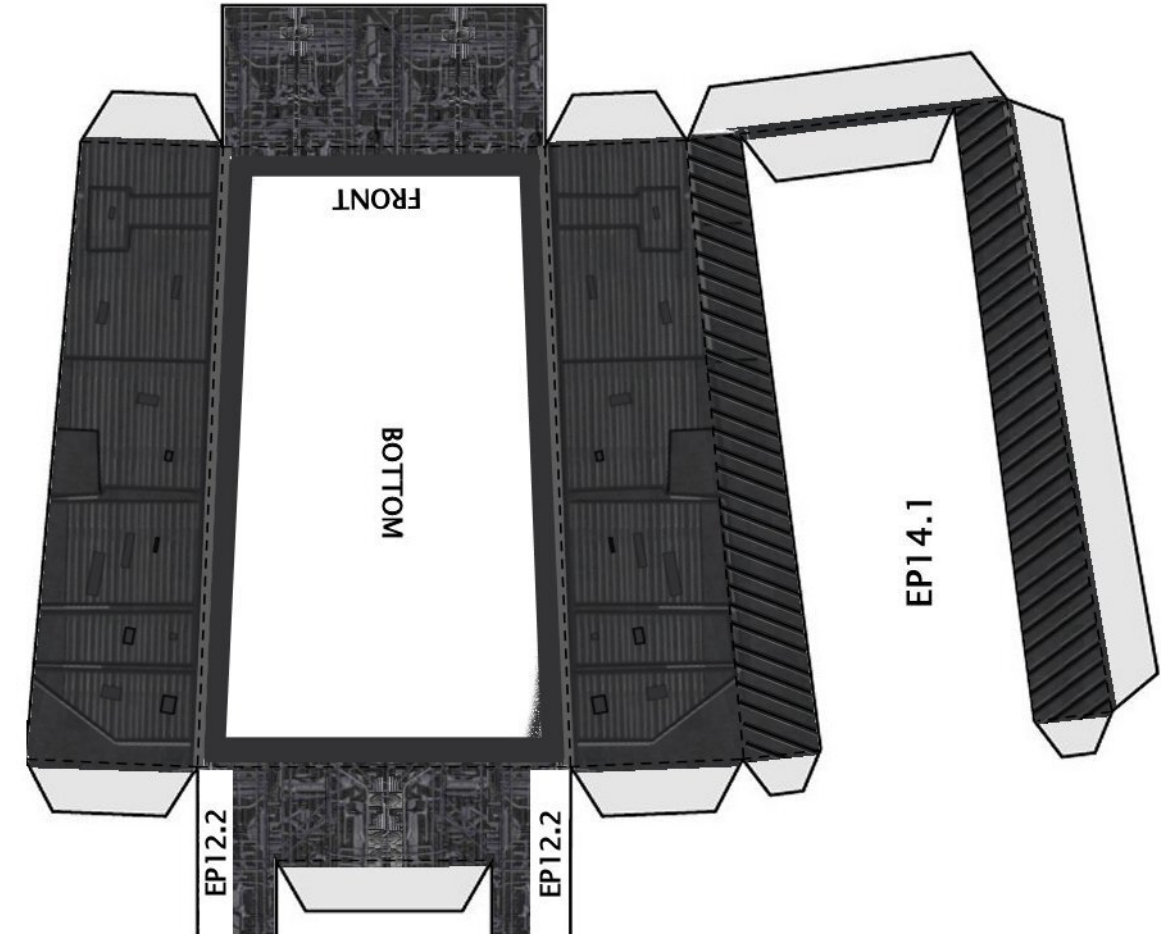

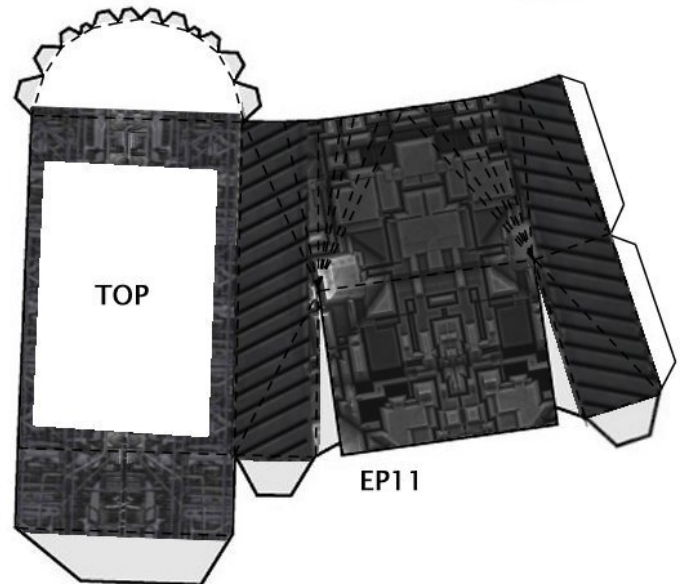
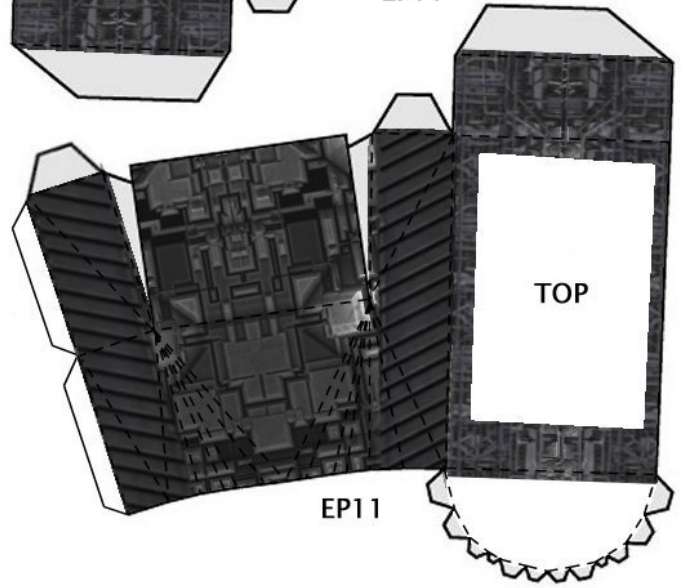
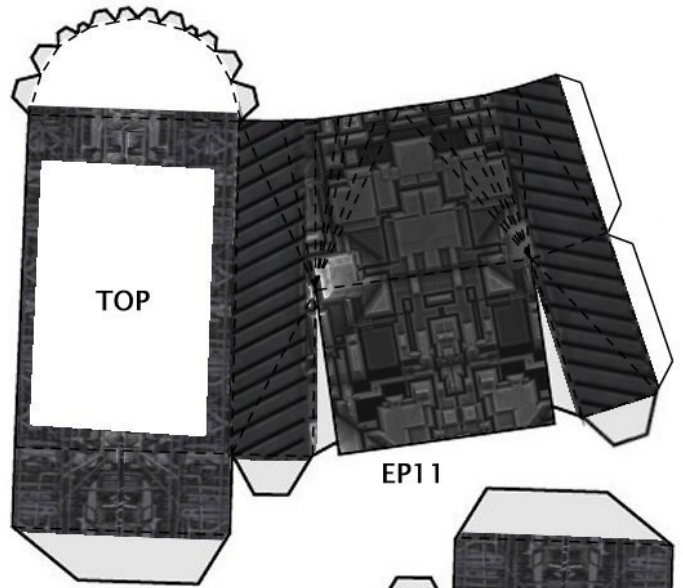
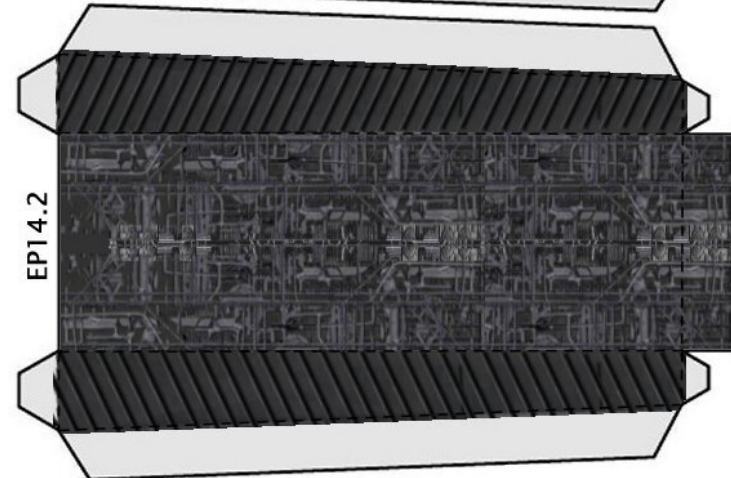
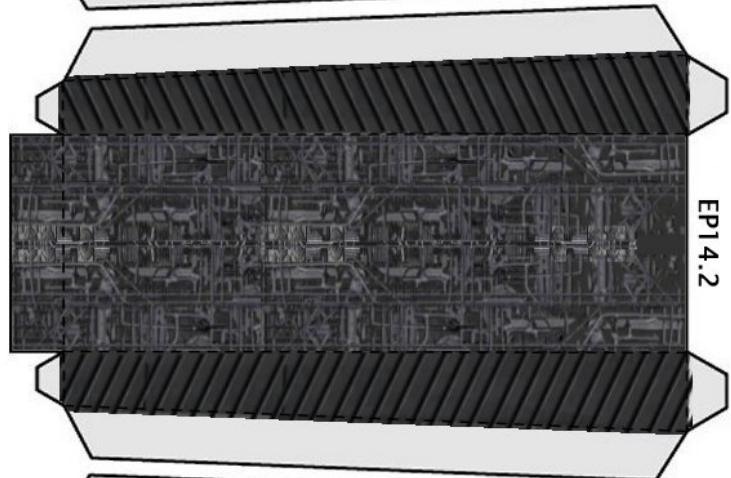
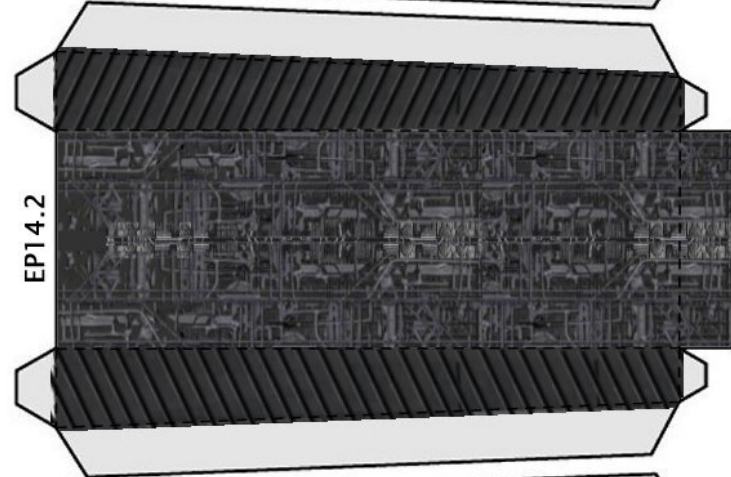
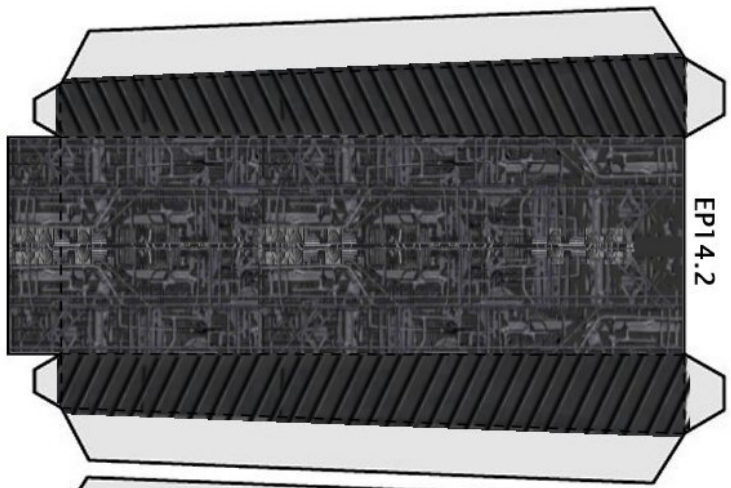

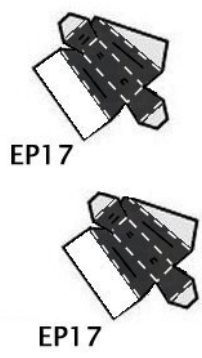
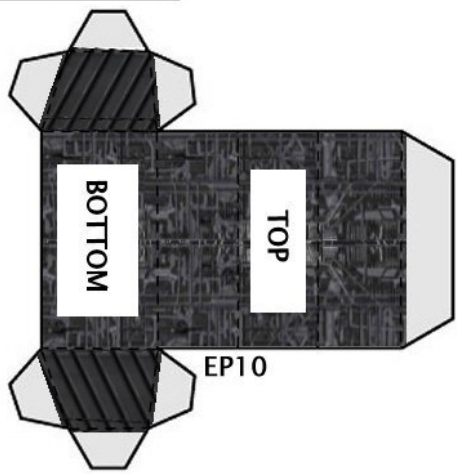
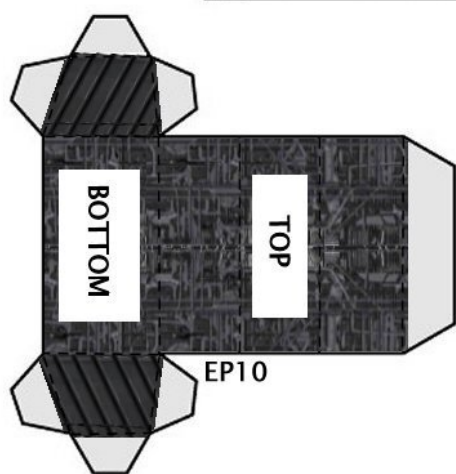
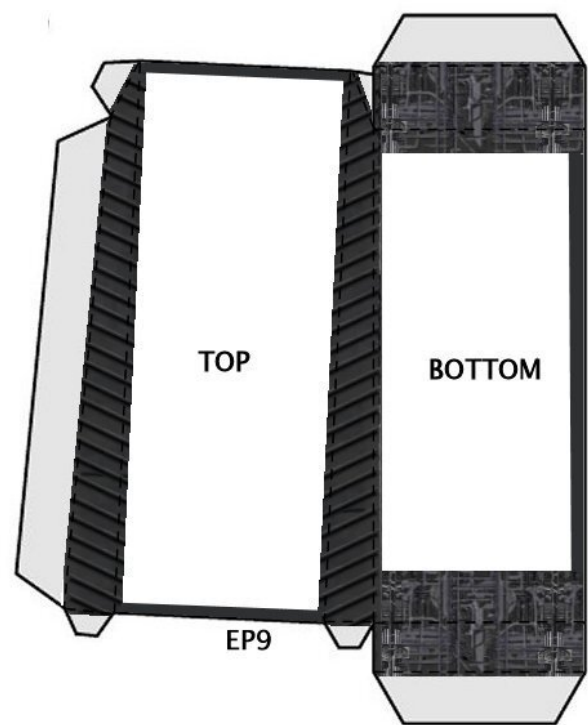
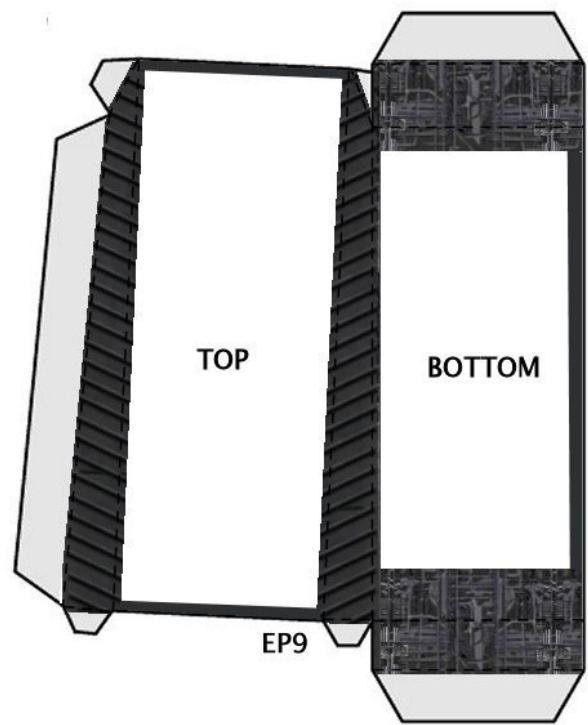
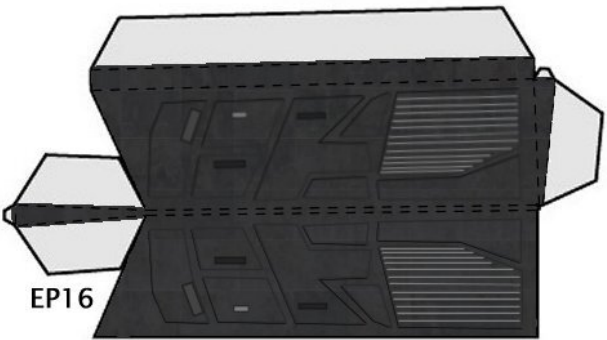
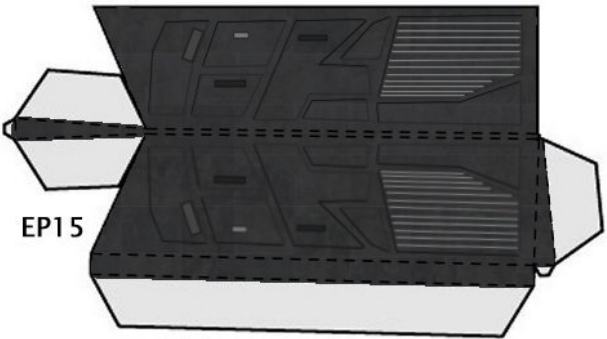
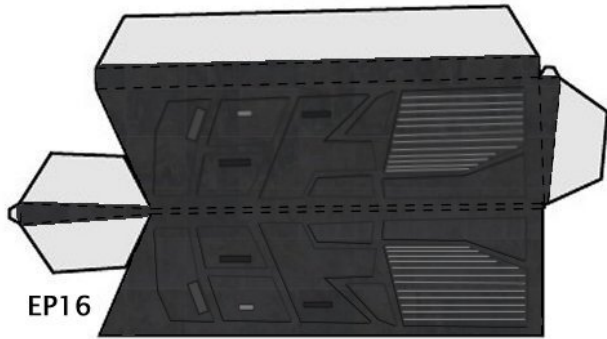
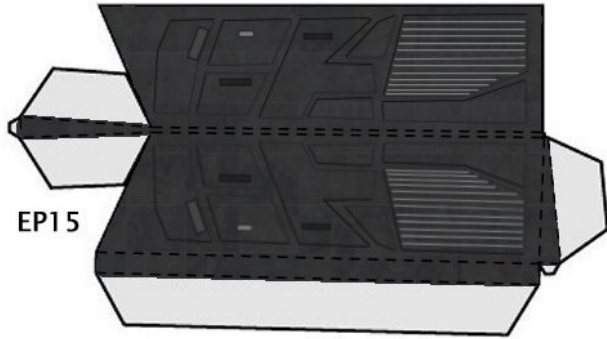

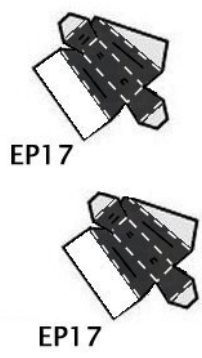
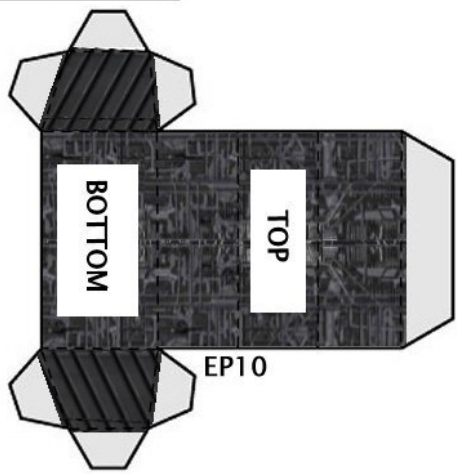
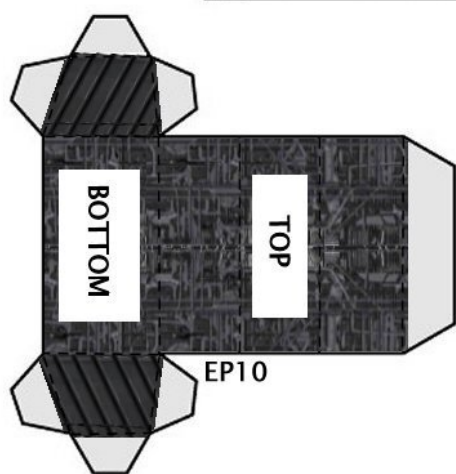
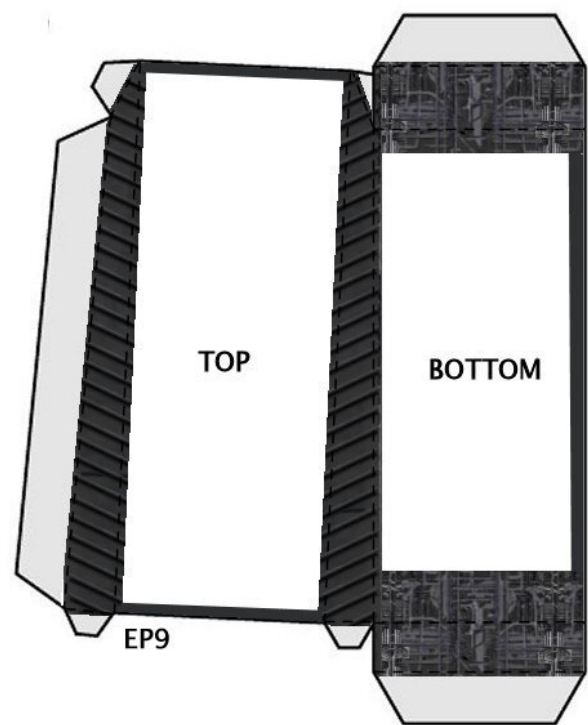
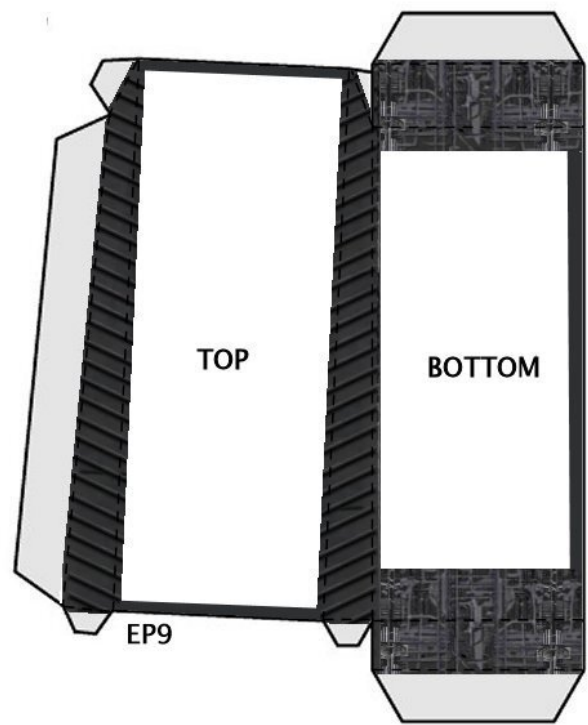
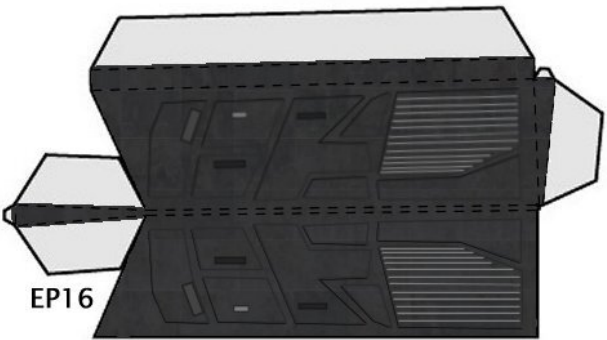
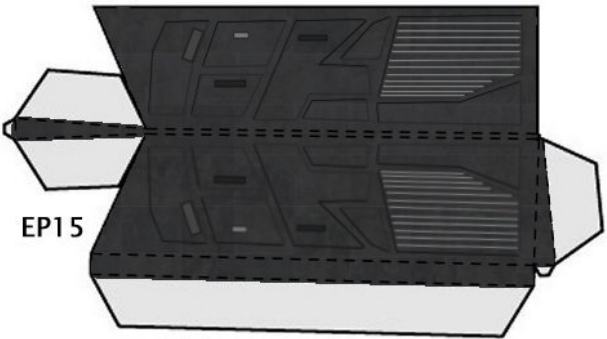
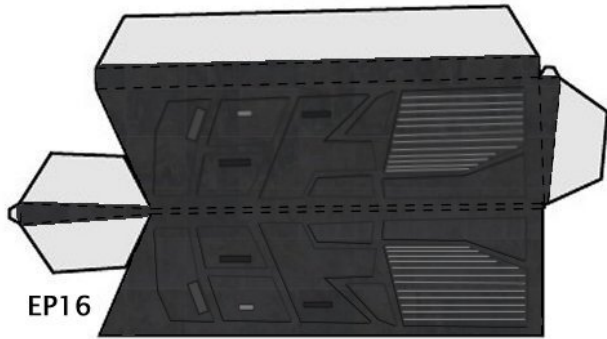
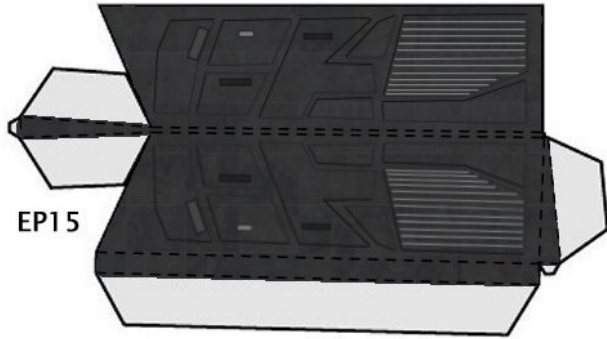

EP12.1

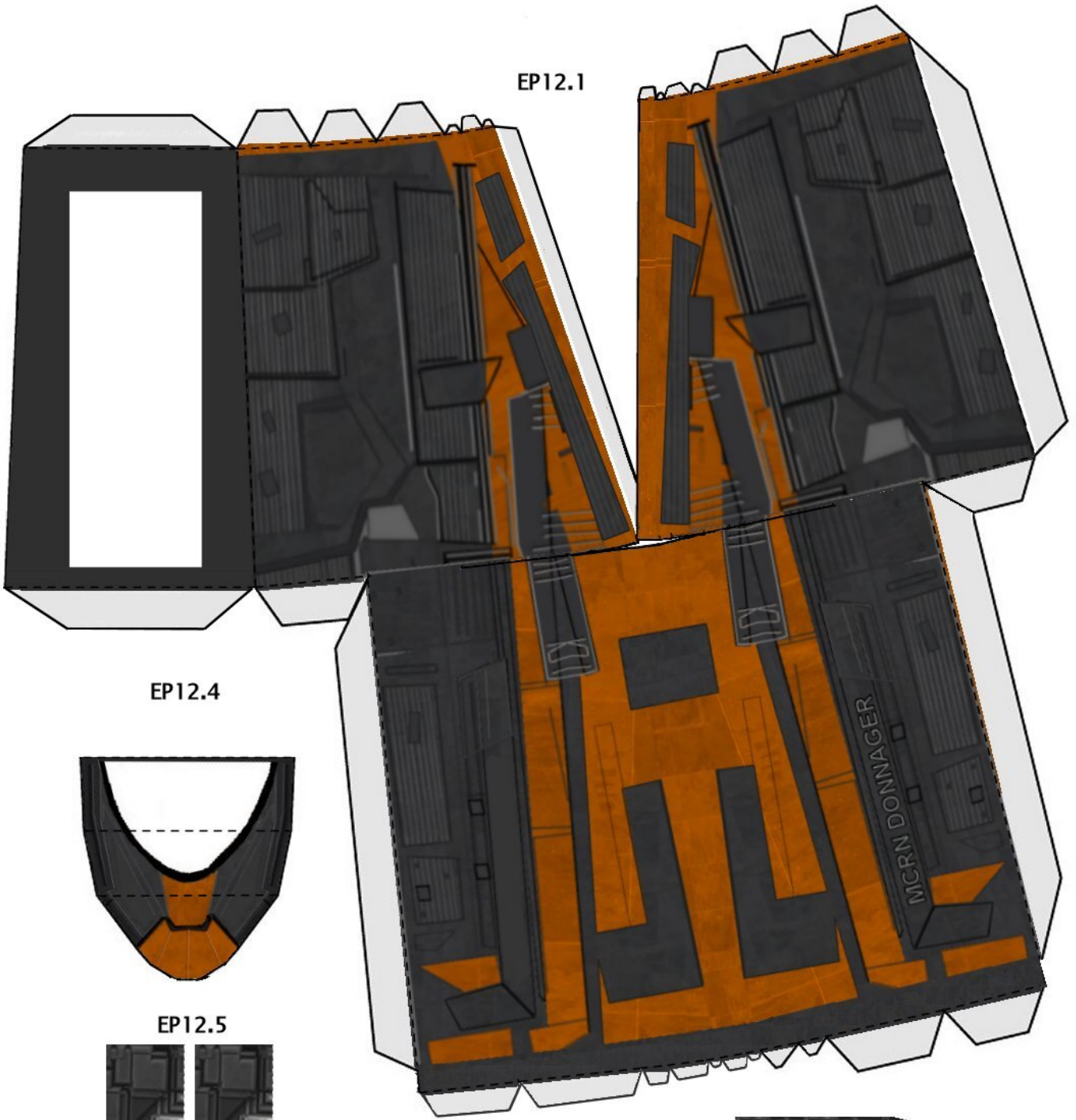

EP12.4

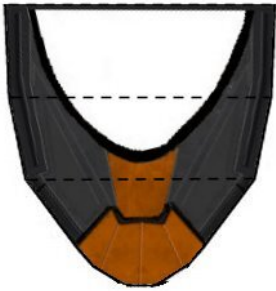

EP12.5

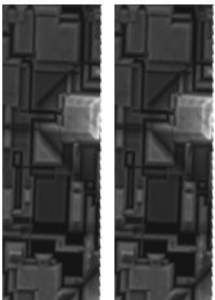

EP12.2 L + R

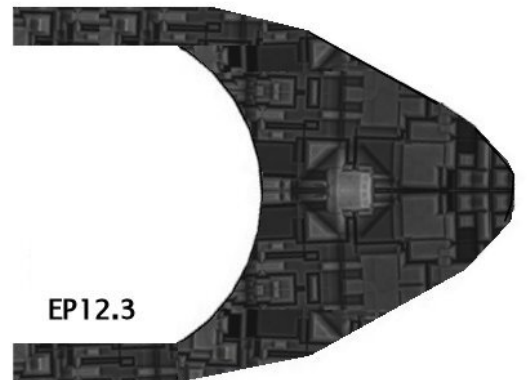

EP12.3

EP12.1

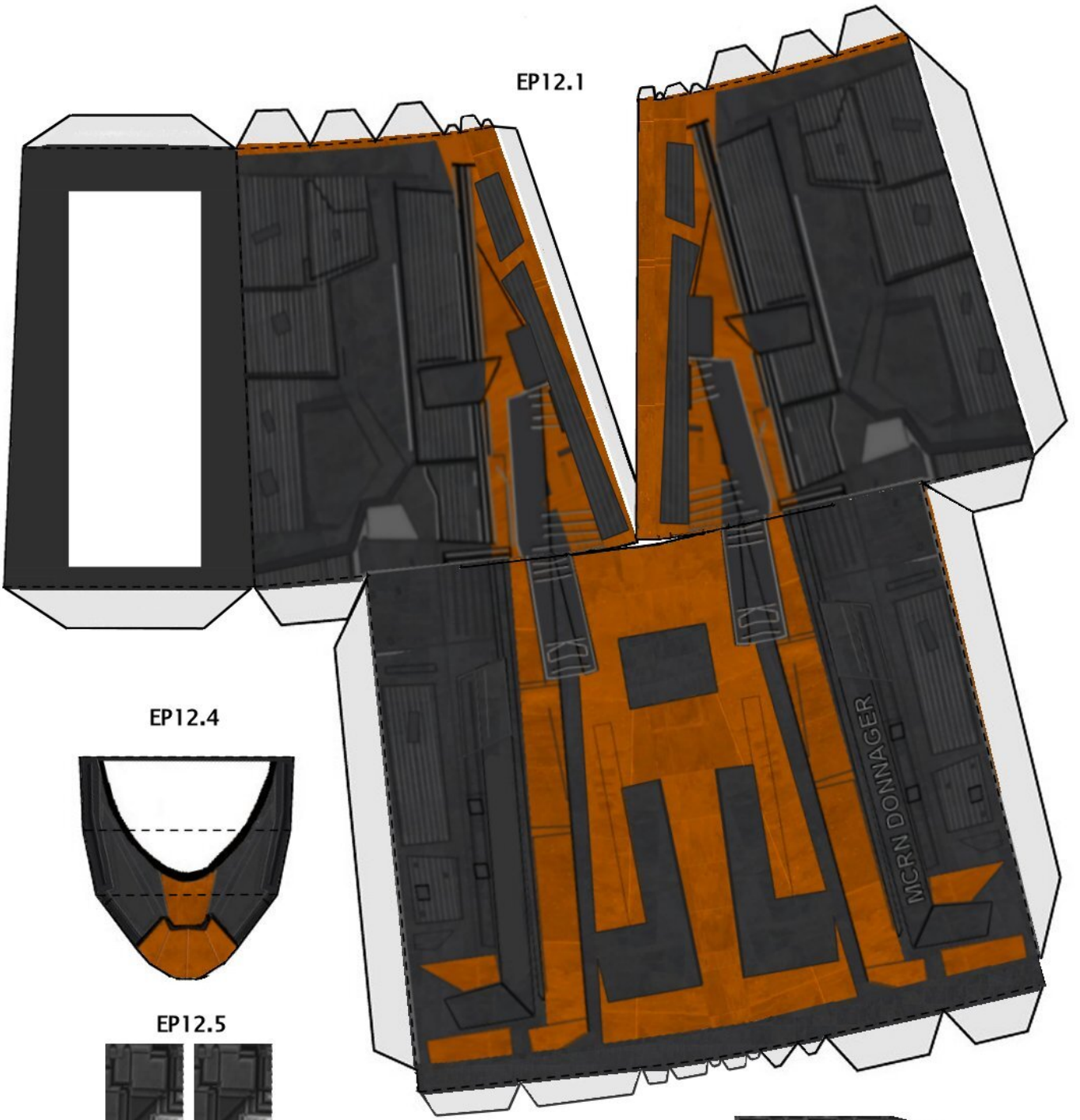

EP12.4

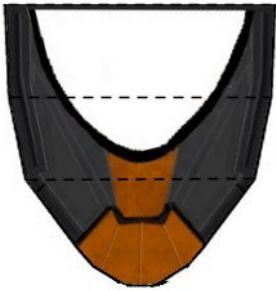

EP12.5

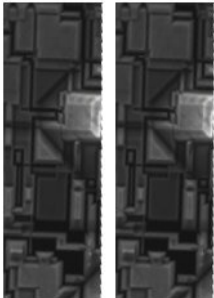

EP12.2 L + R

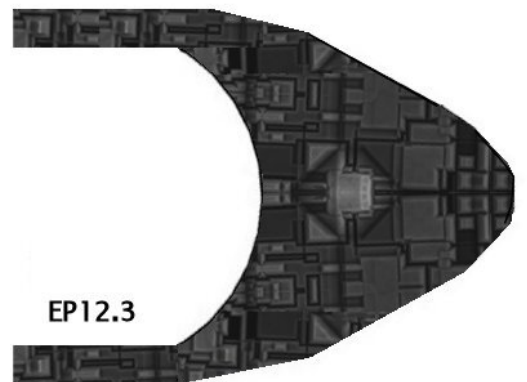

EP12.3

EP12.1

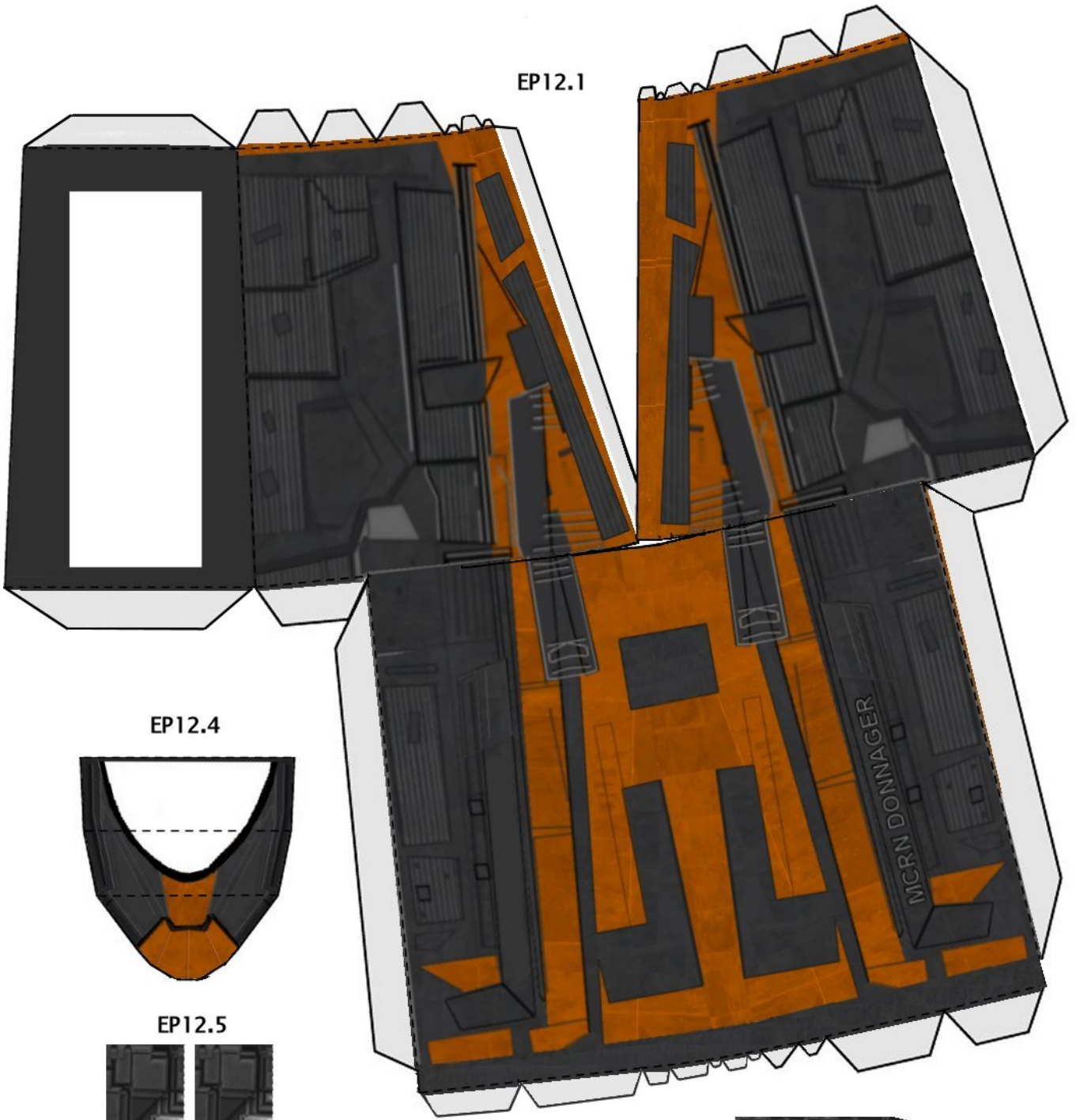

EP12.4

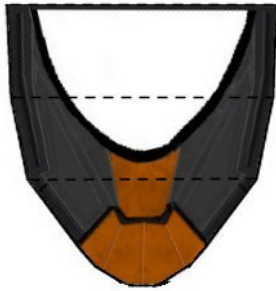

EP12.5



EP12.2 L + R

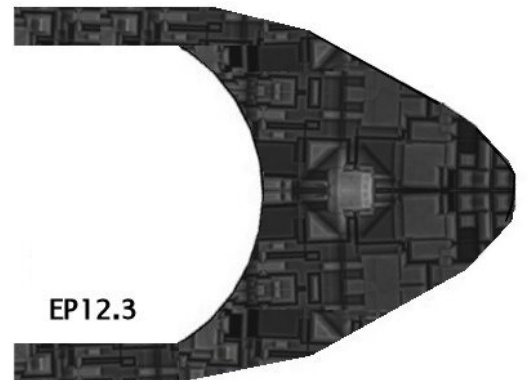

EP12.3

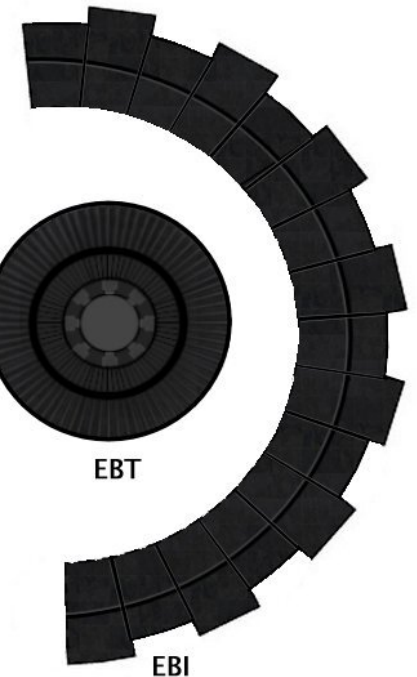
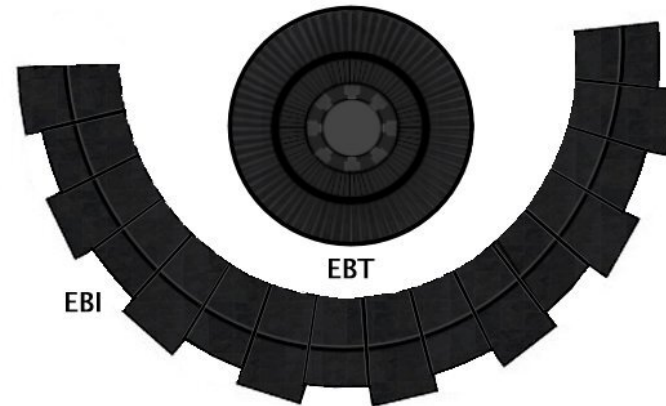
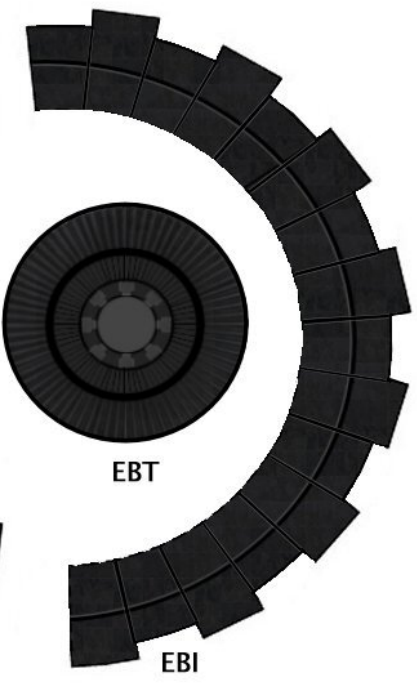
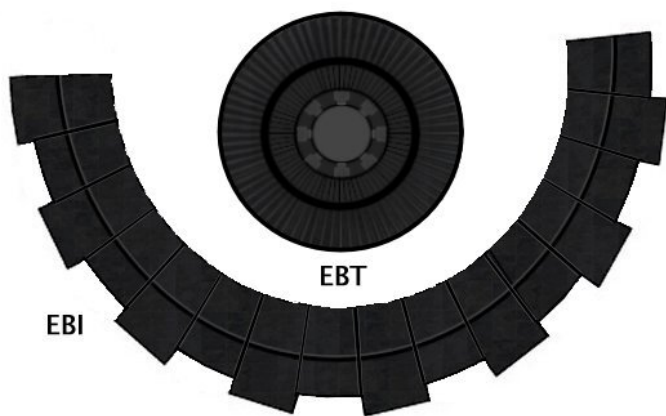

EP12.1

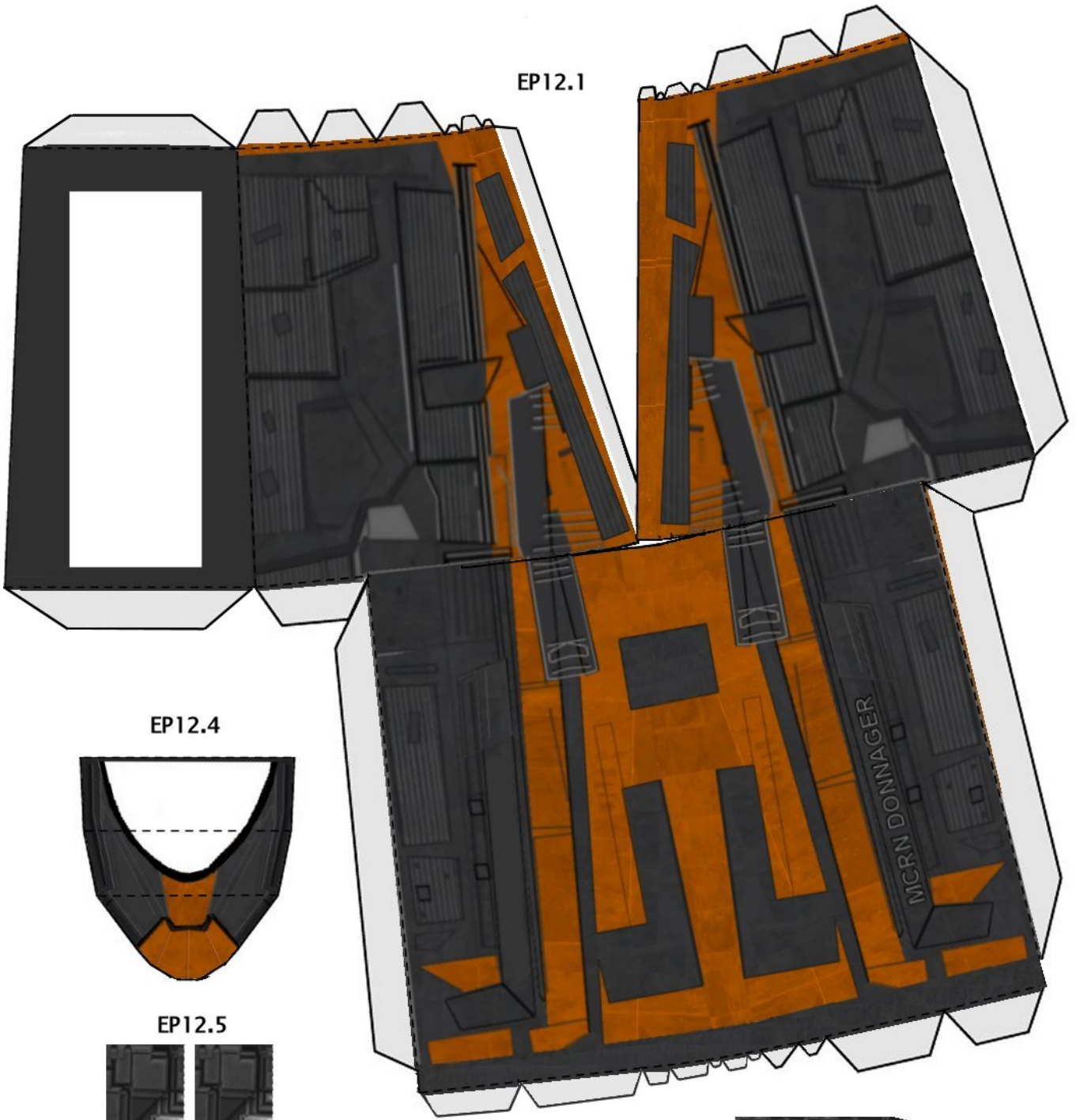

EP12.4

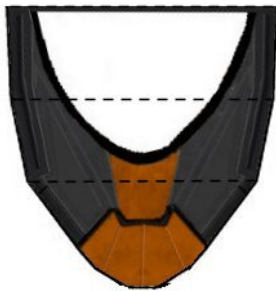

EP12.5

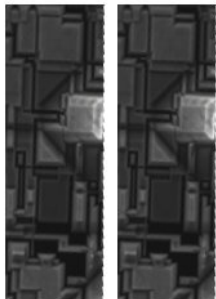

EP12.2 L + R

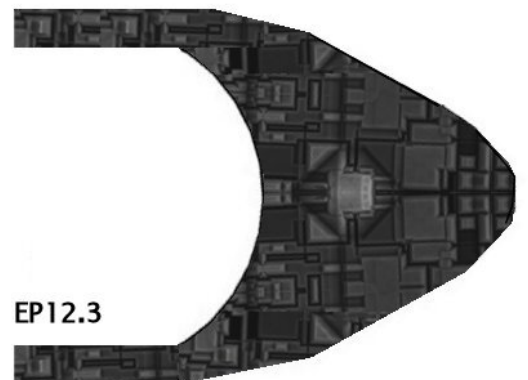

EP12.3

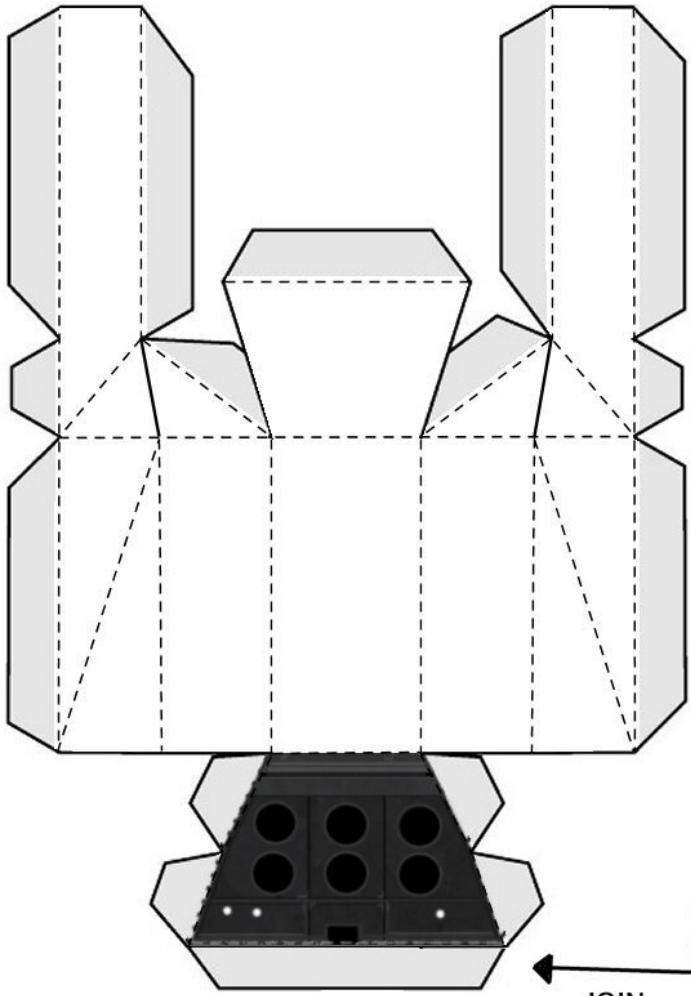

MCI1.1

JOIN

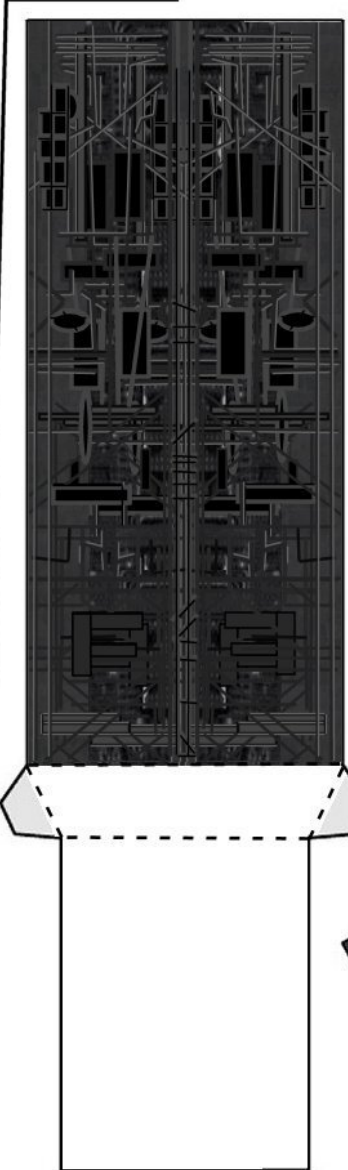

MCI1.2

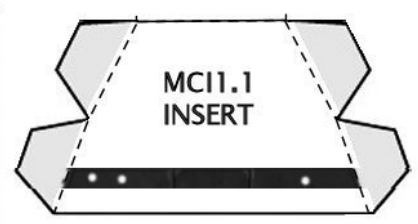

MCI1.1
INSERT

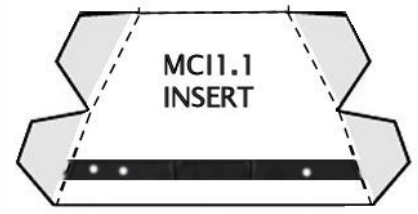

MCI1.1
INSERT

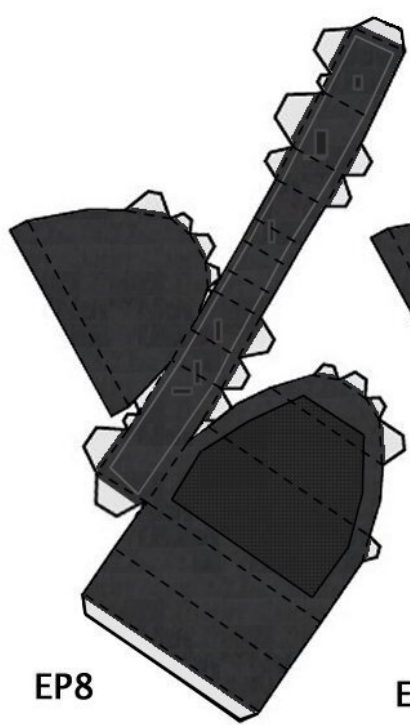

EP8

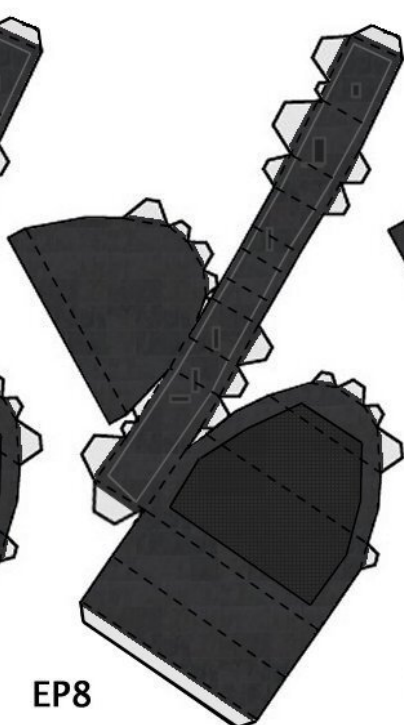

EP8

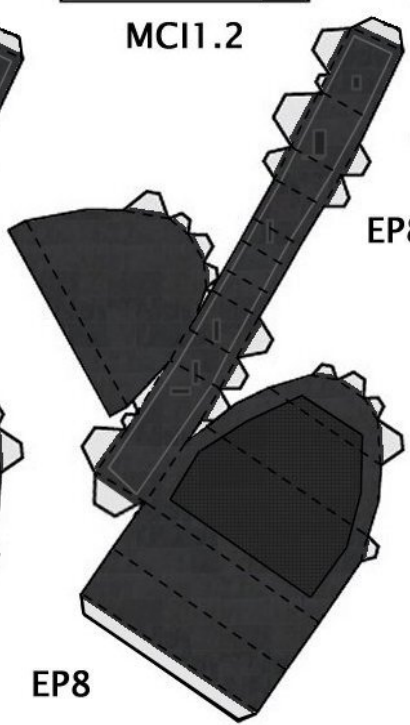

EP8

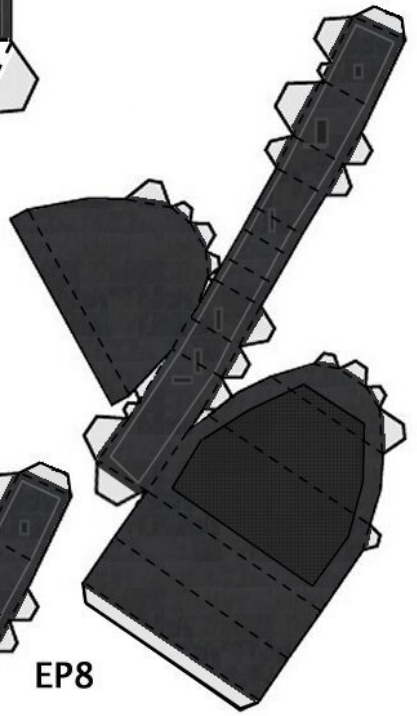

EP8

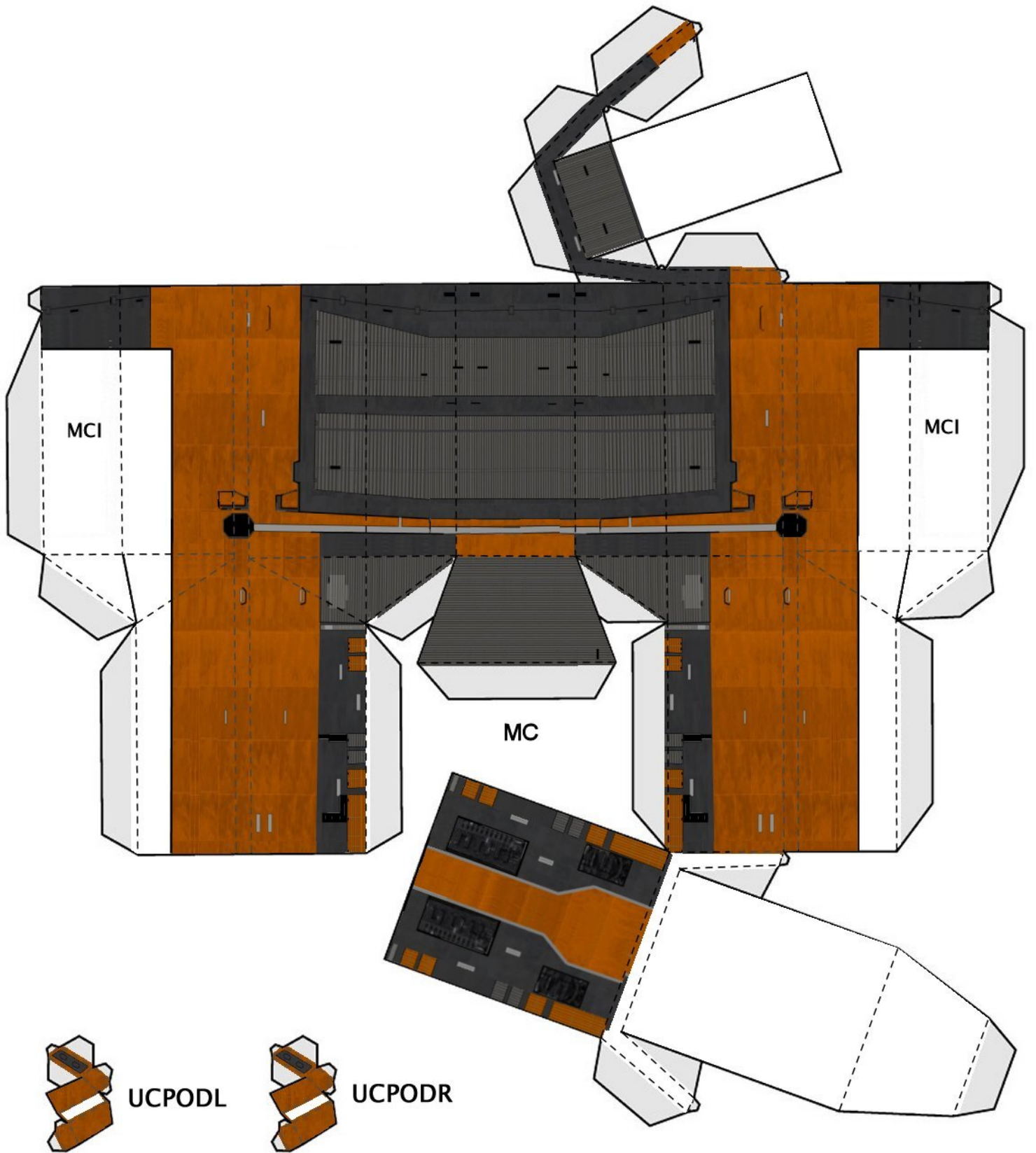

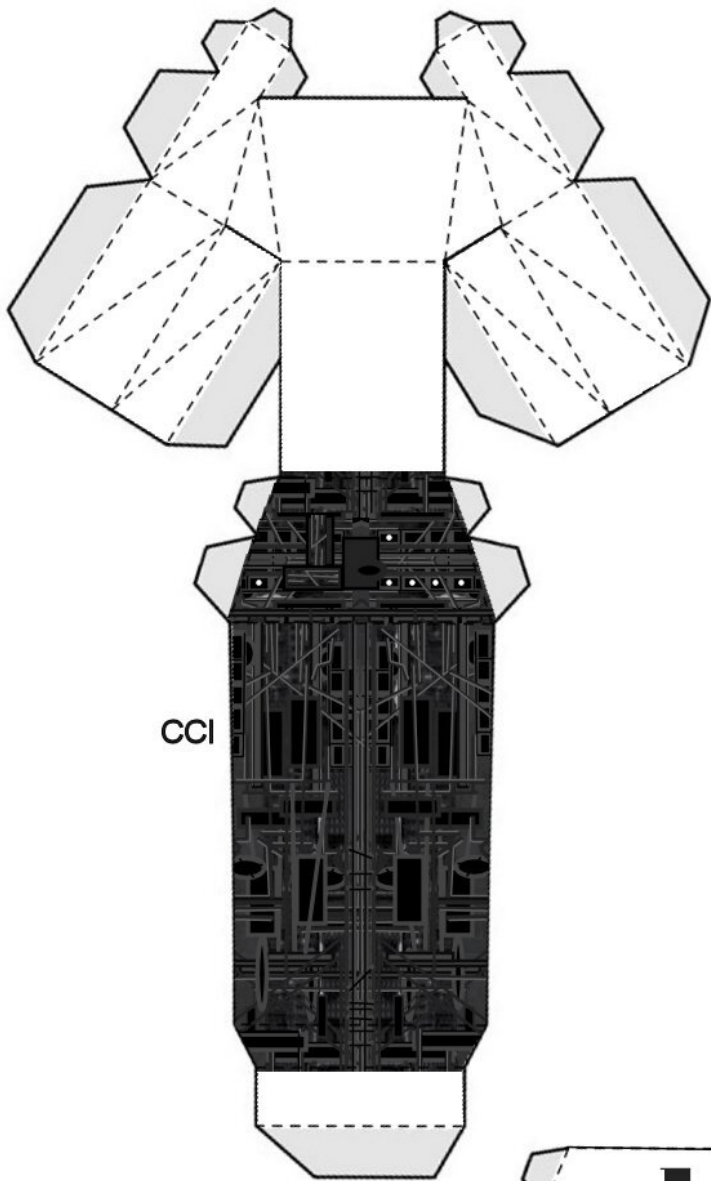

CCI

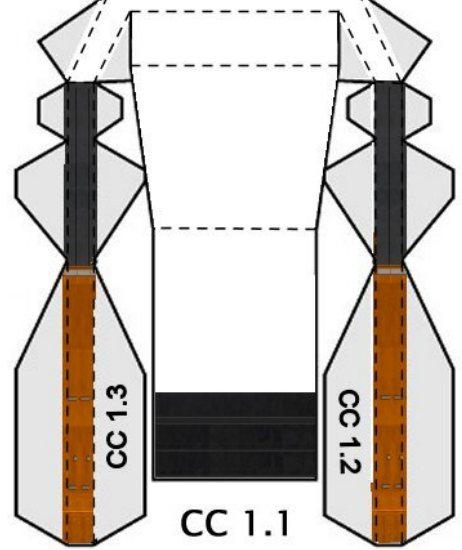
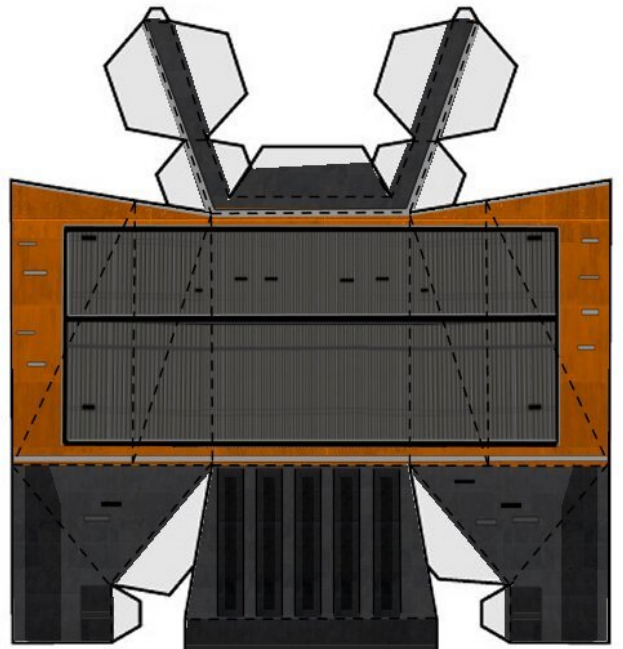

CC 1.1

CC 1.3

CC 1.2

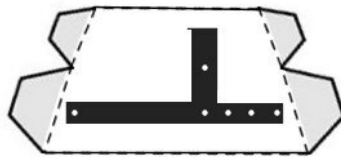

CCI Insert

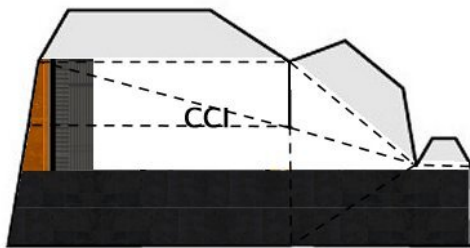

CC 1.2

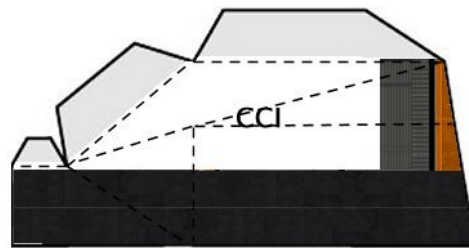

CC 1.3

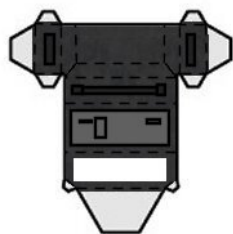

RG1

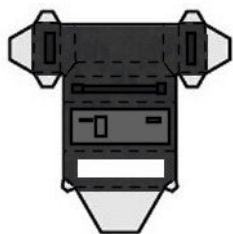

RG1

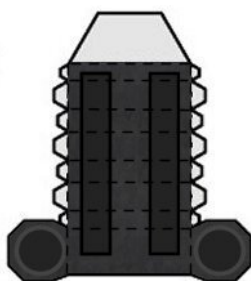

RG2

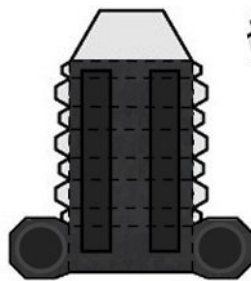

RG2



RG3



RG3

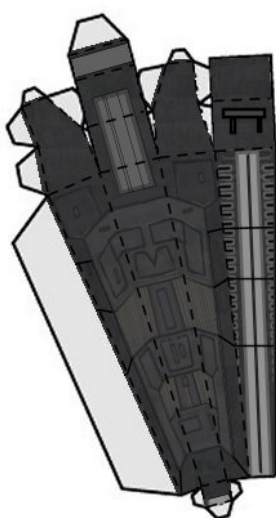

RG5

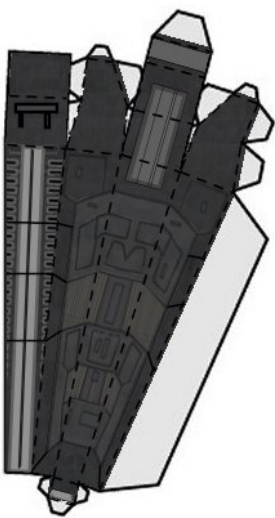

RG4

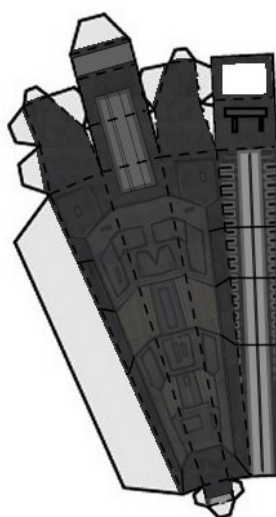

RG5

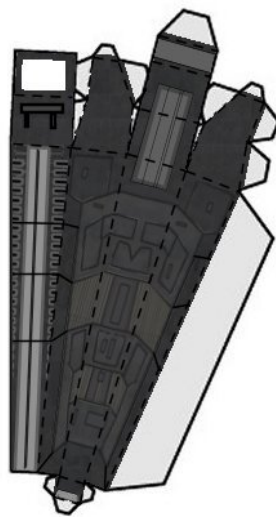

RG4

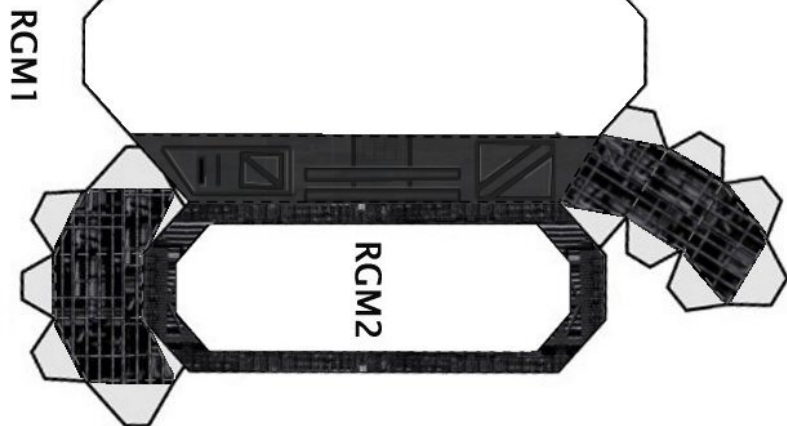
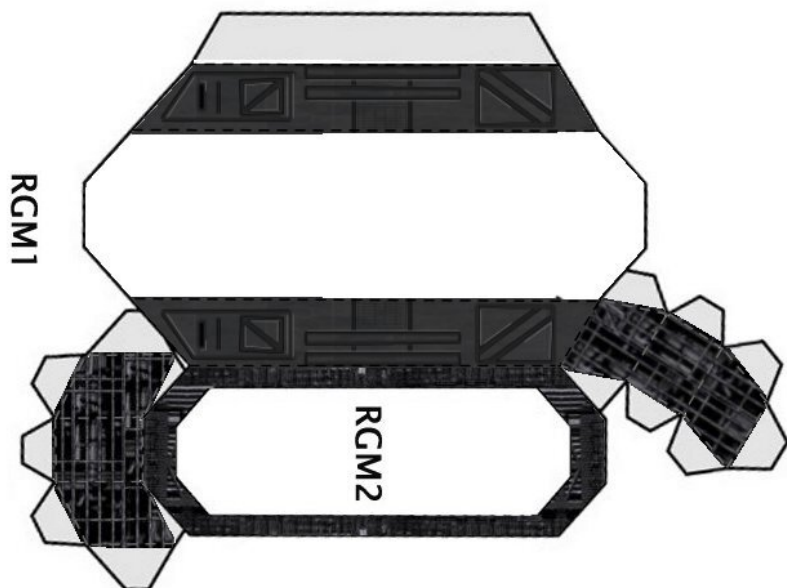

MB1 STRUT PAGE 1

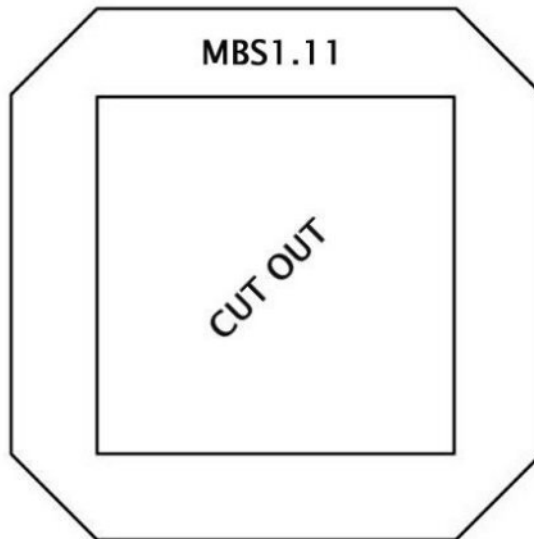
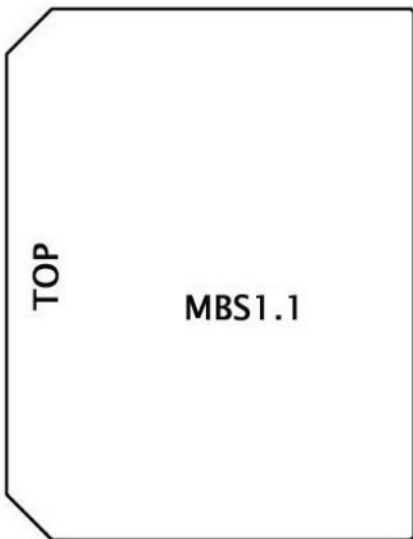
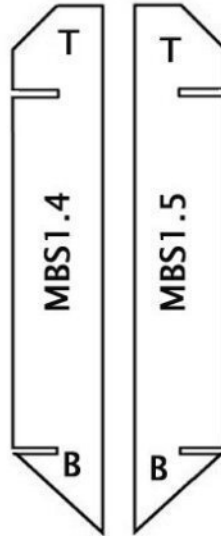
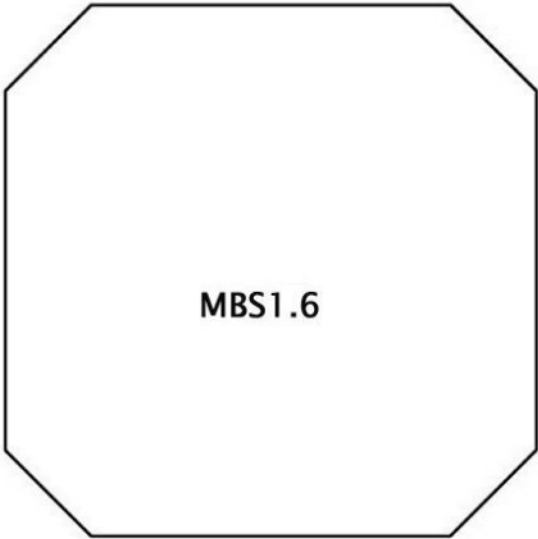
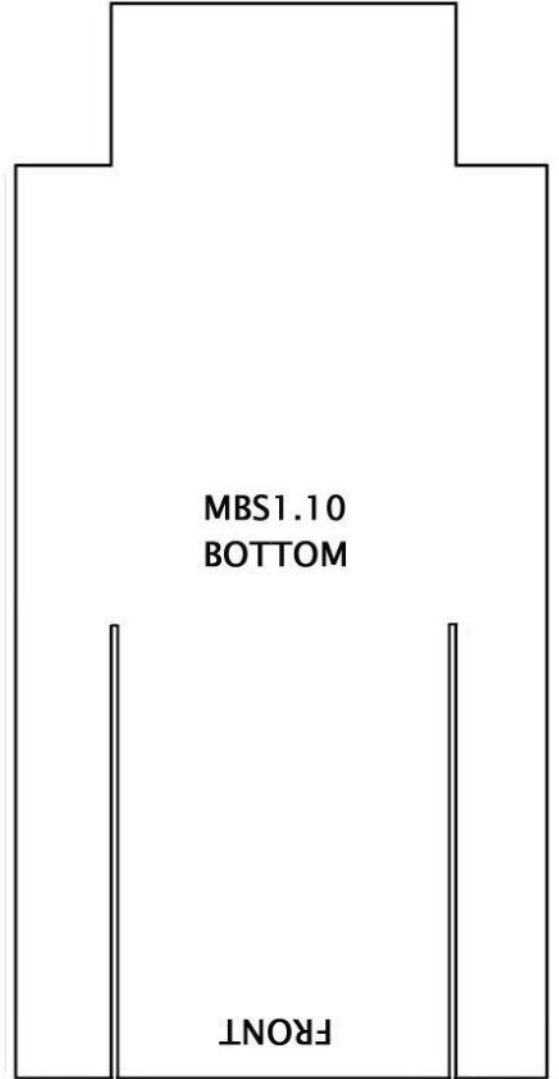
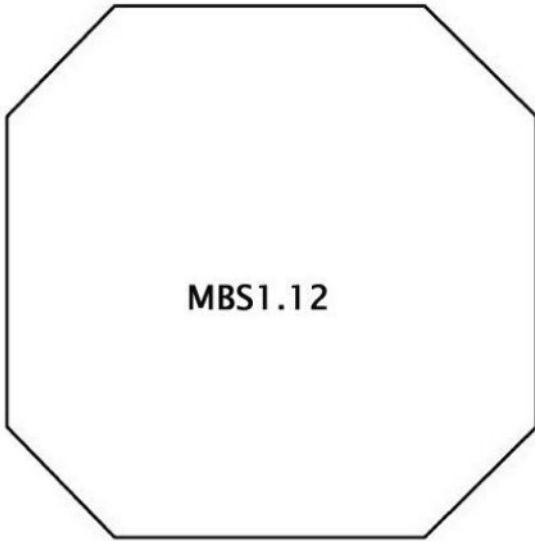

Strut number build
front to back

MB1 STRUT PAGE 2

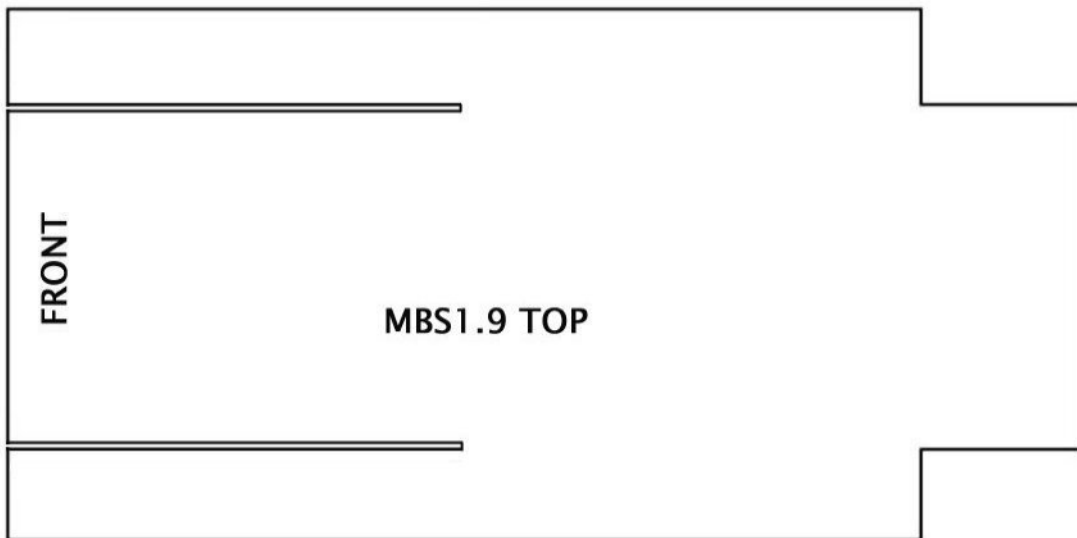
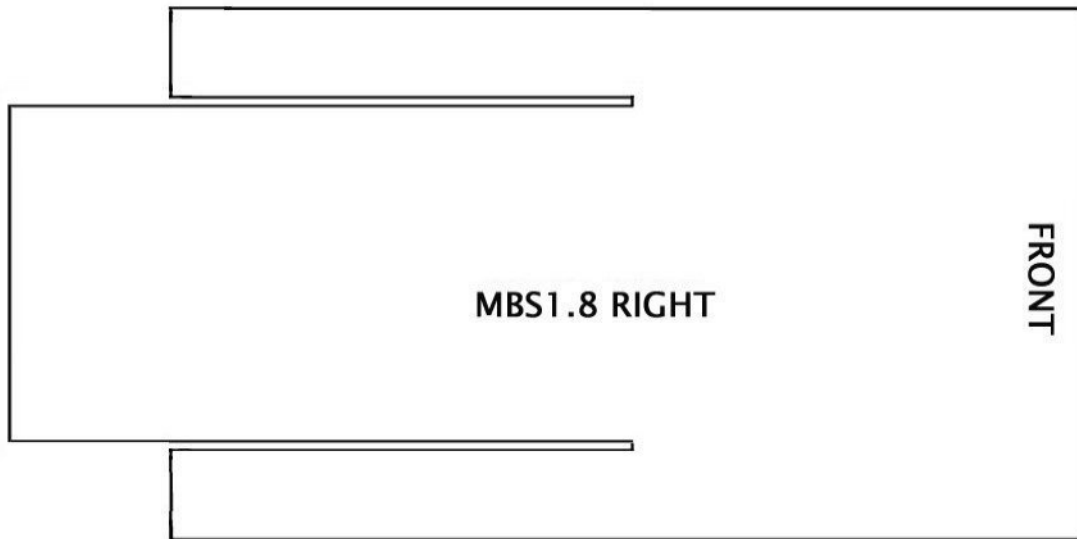

MB2 STRUT

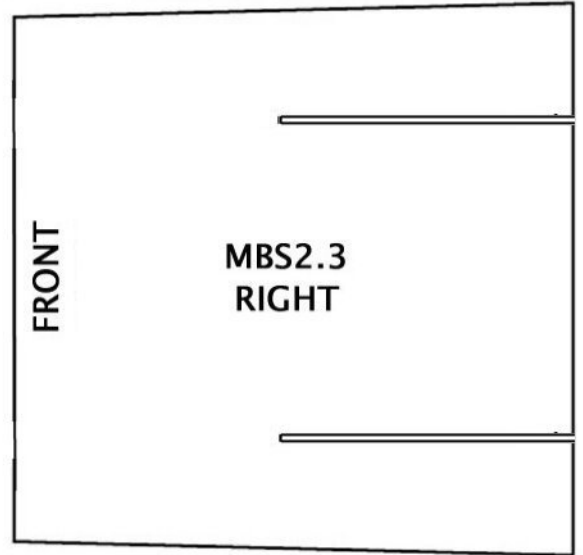
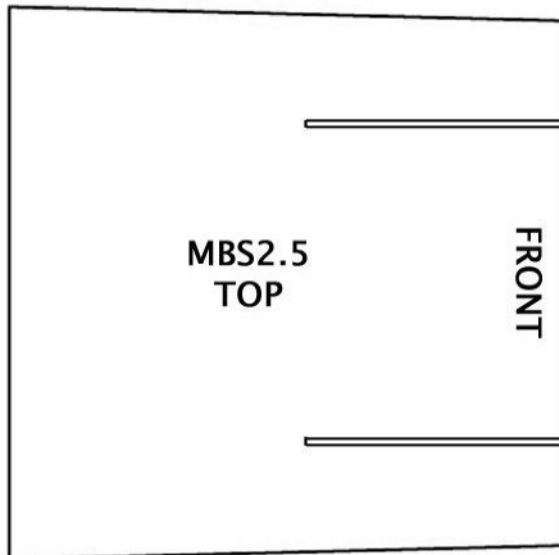
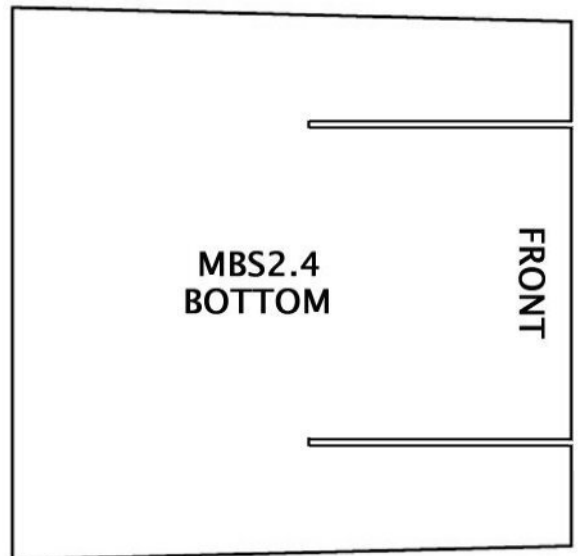
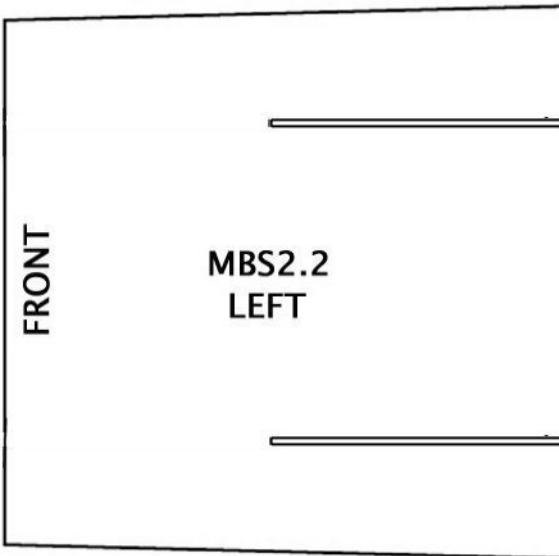
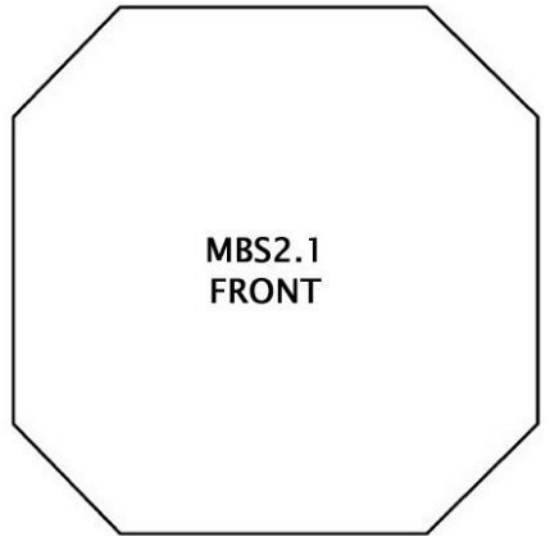
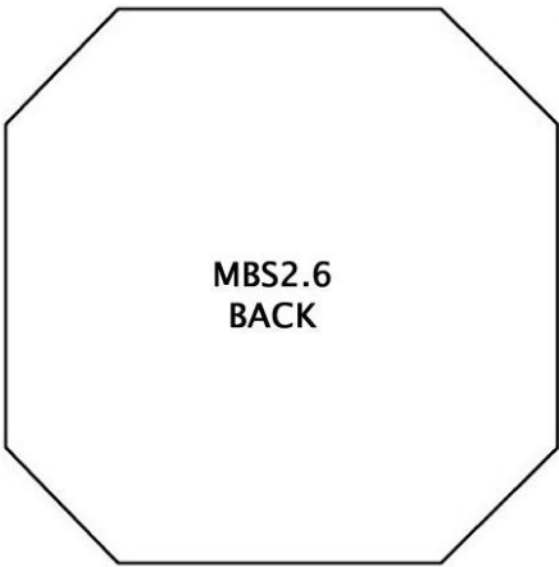

MB3 STRUT PAGE 1

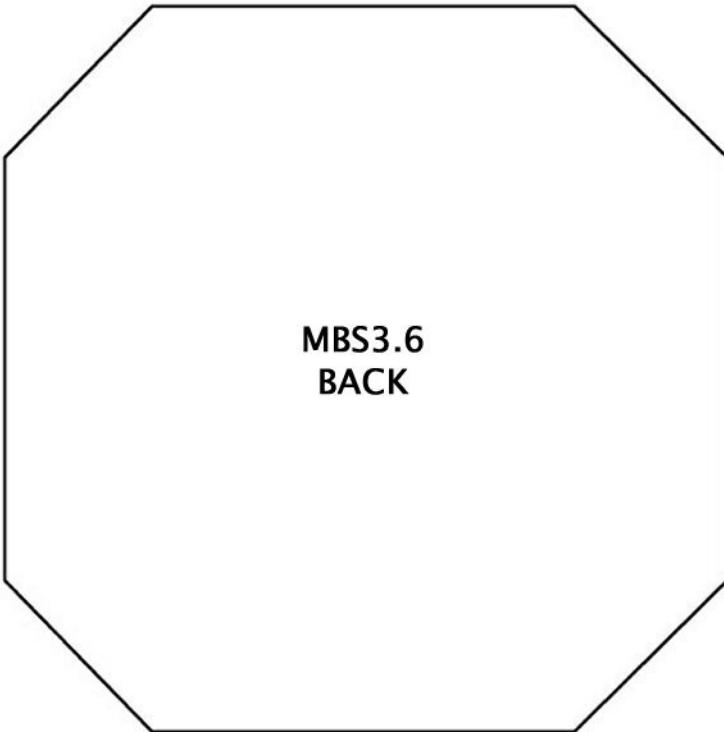

**MBS3.6
BACK**

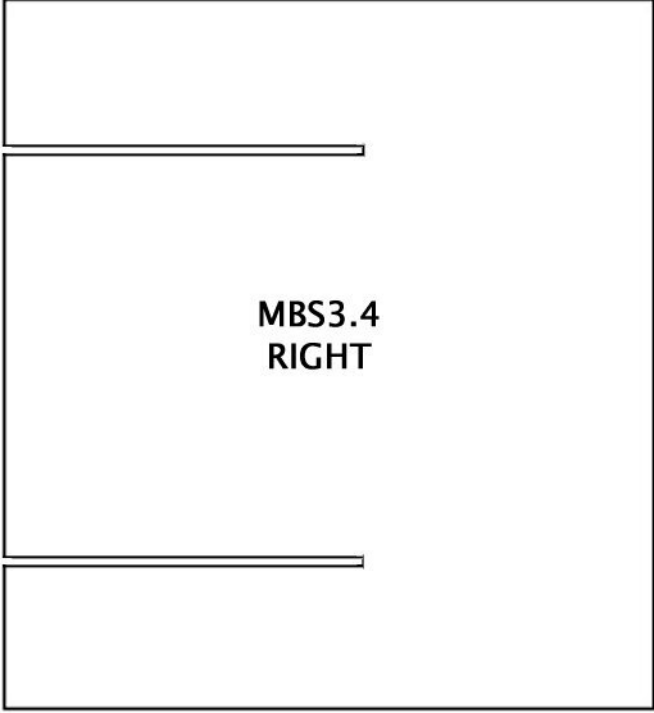

**MBS3.4
RIGHT**

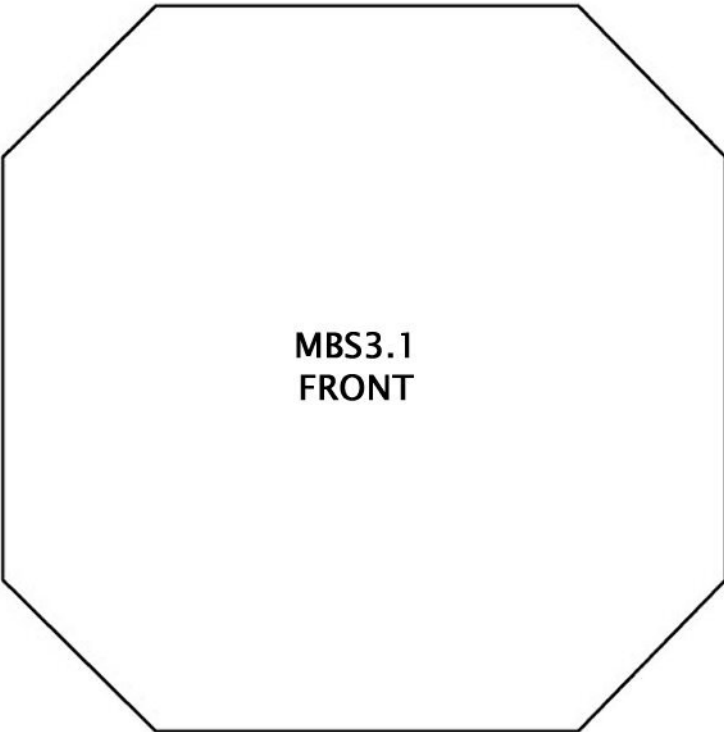

**MBS3.1
FRONT**

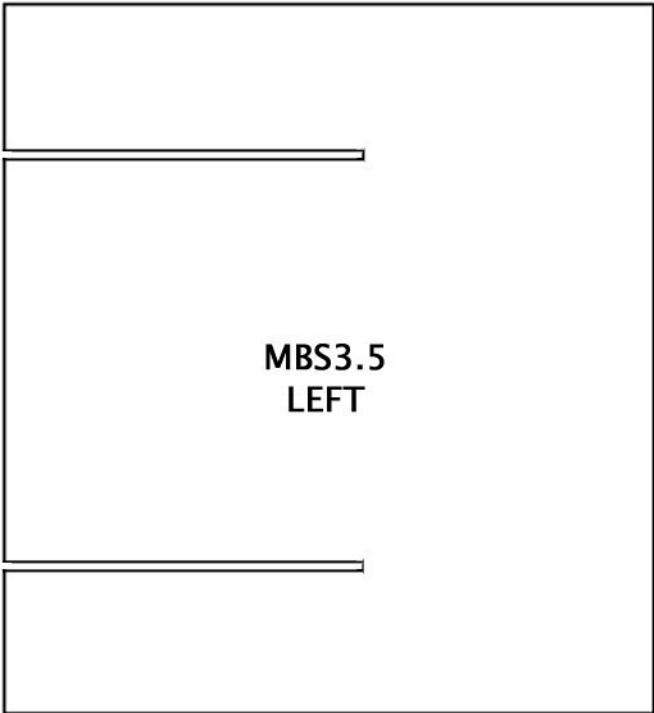

**MBS3.5
LEFT**

MB3 STRUT PAGE 2

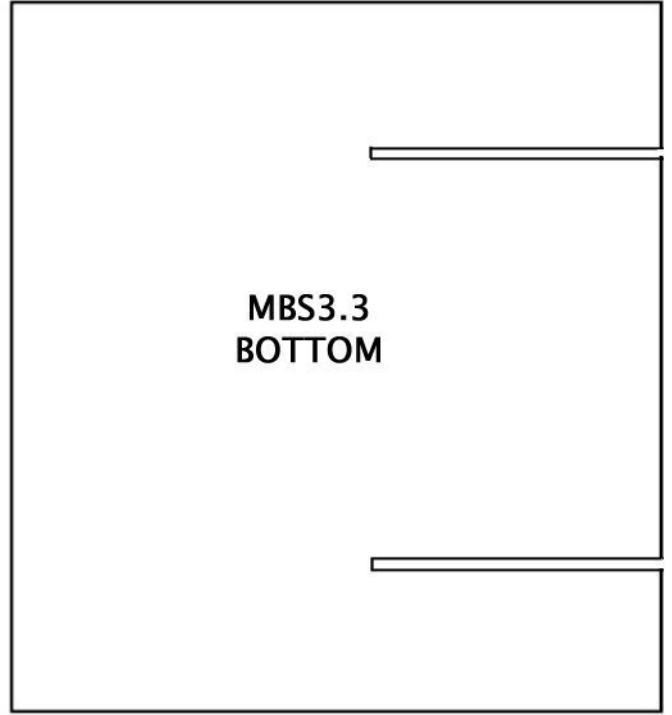
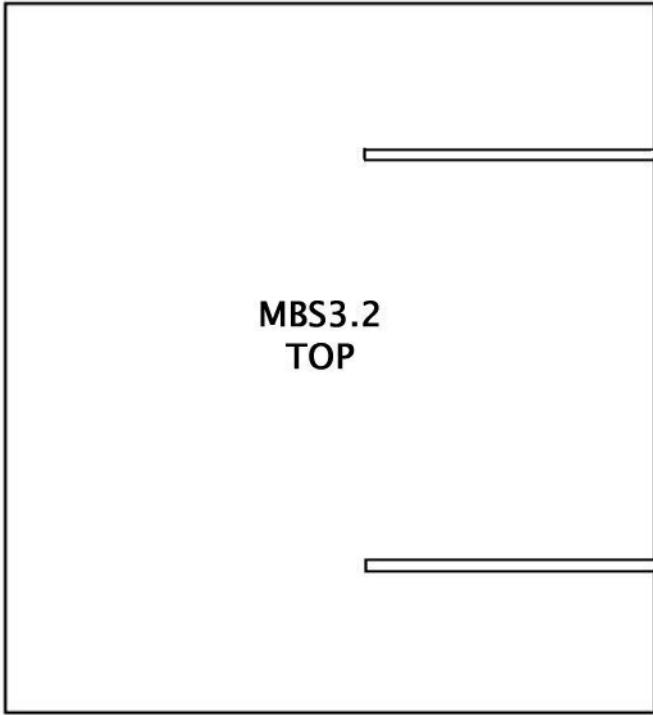

MB4 STRUT PAGE 1

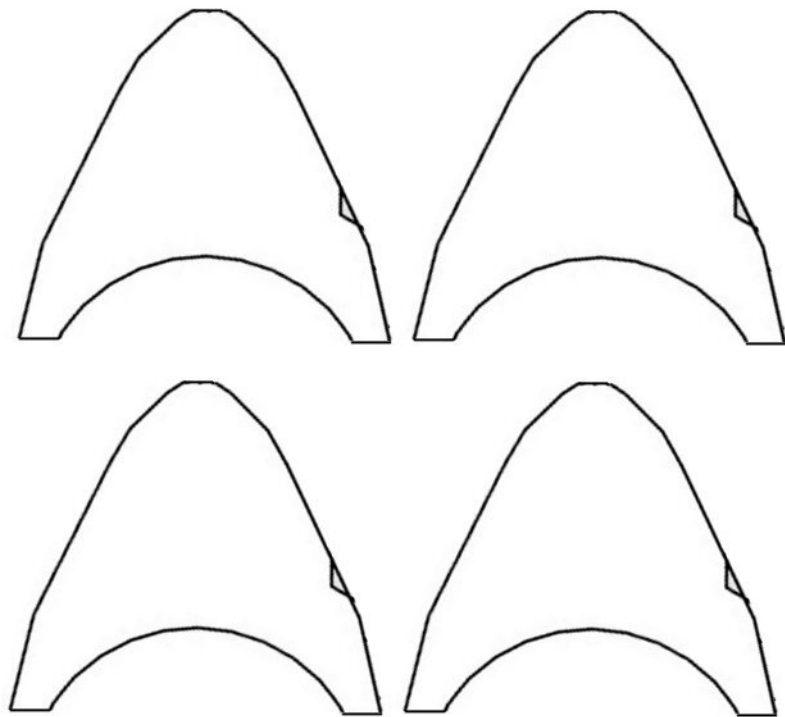

MB5 STRUT PAGE1

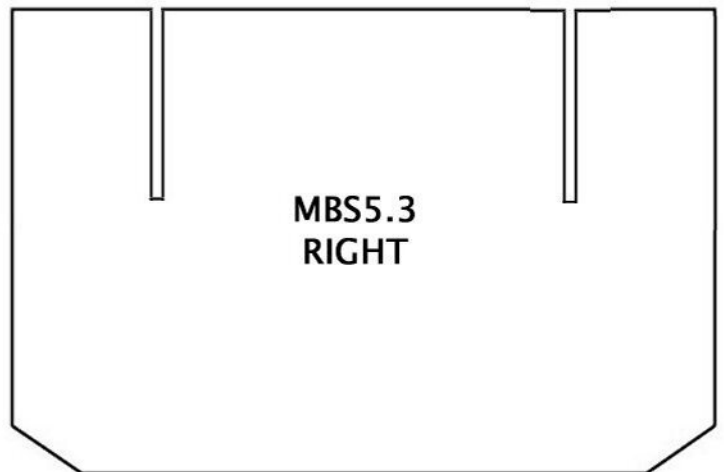
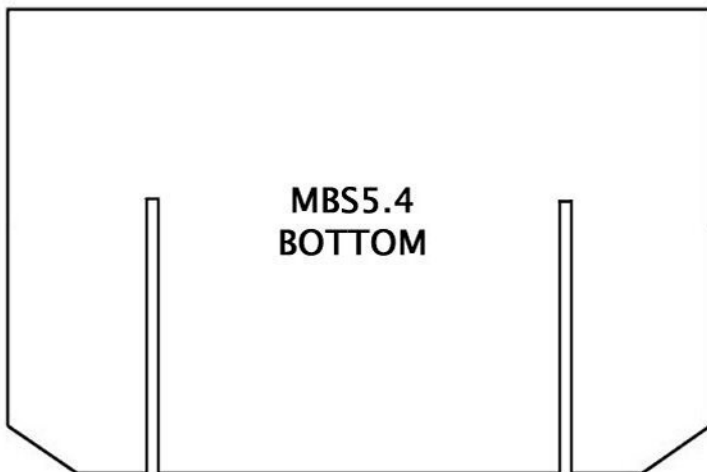
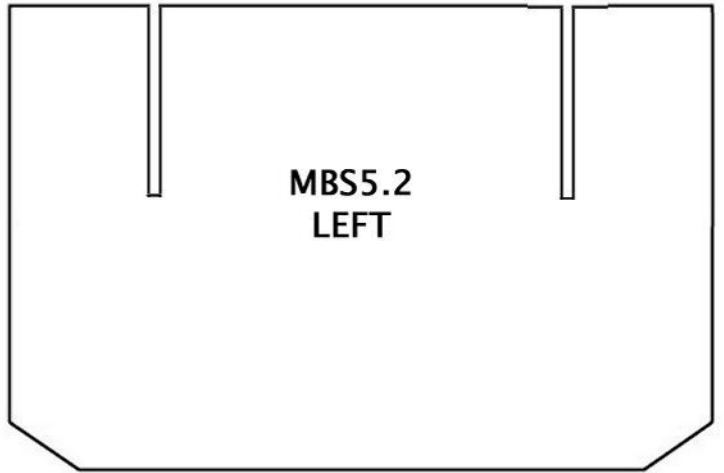
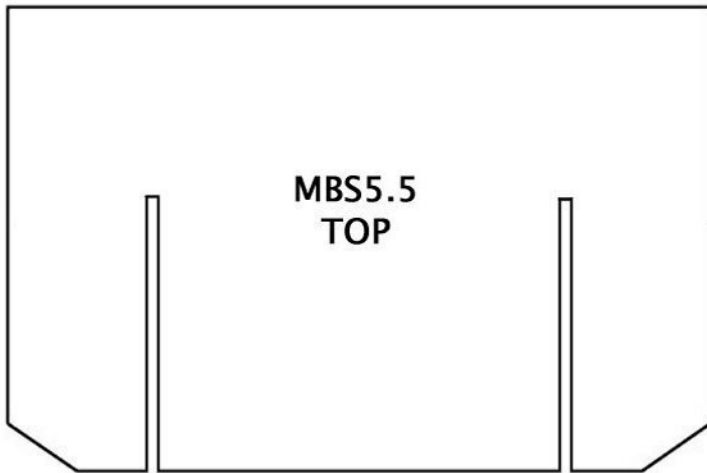
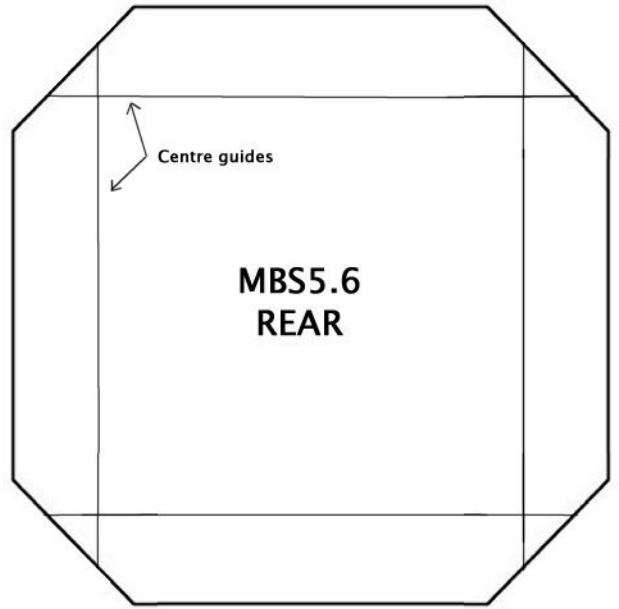
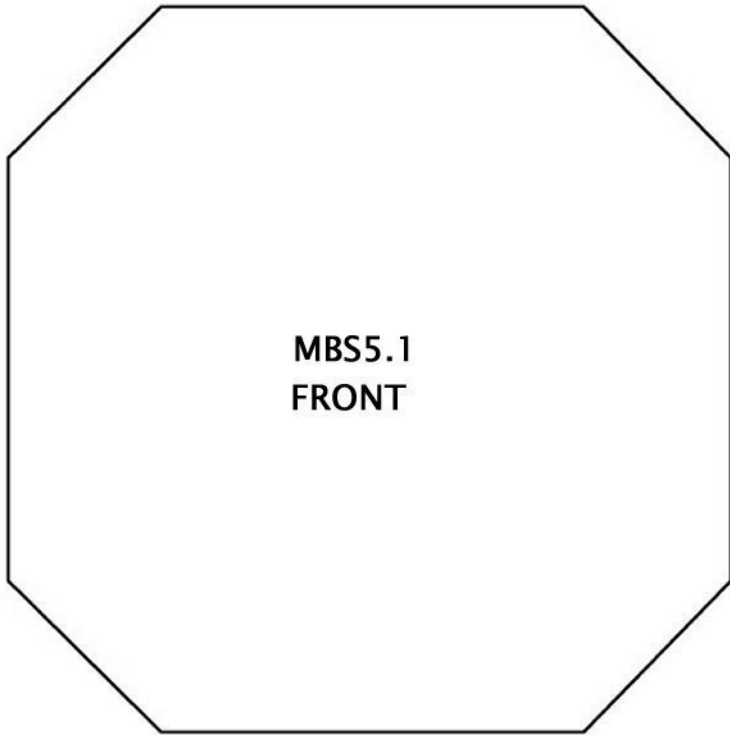

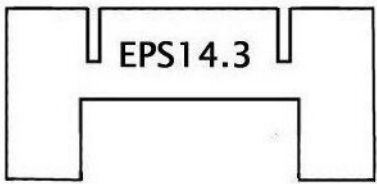
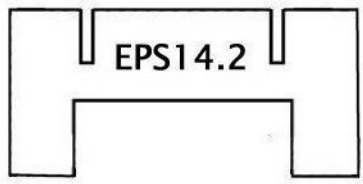
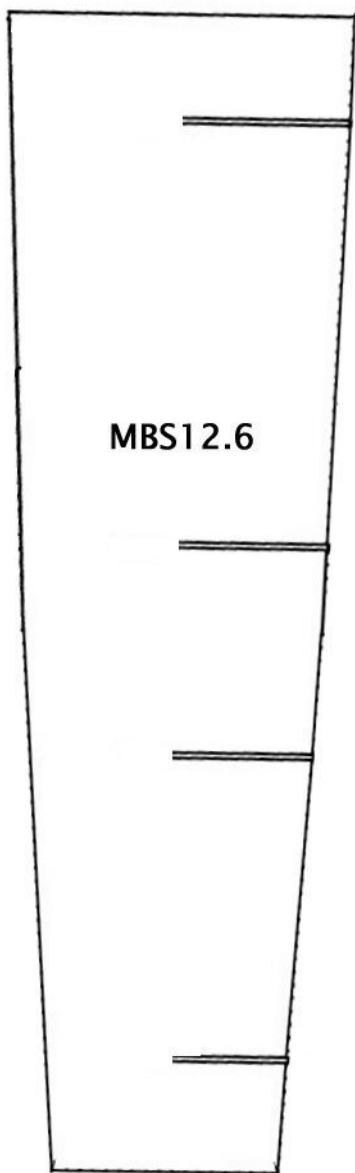
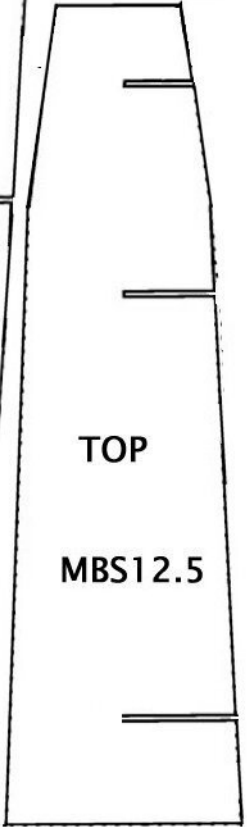
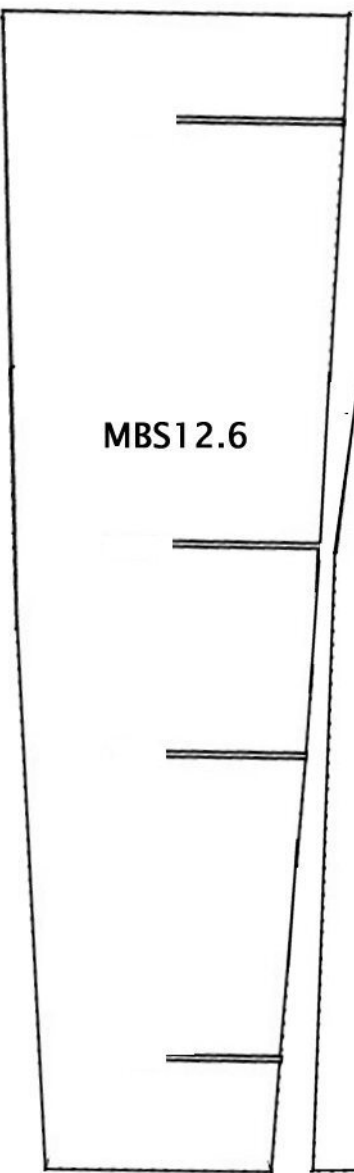
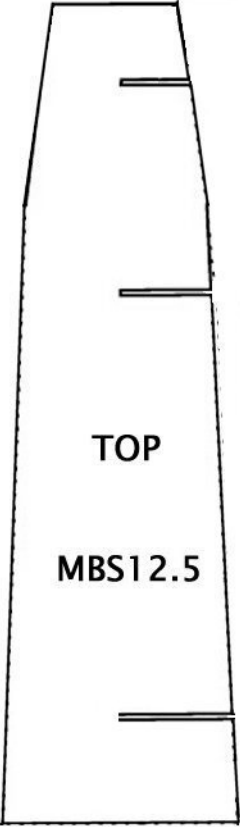
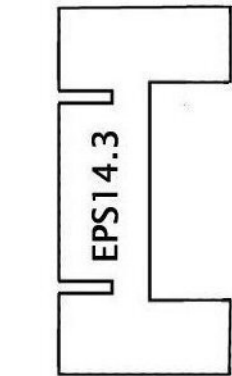
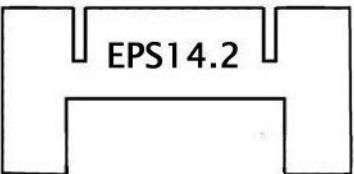
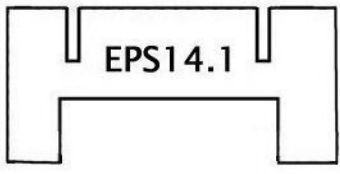
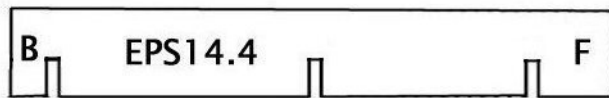

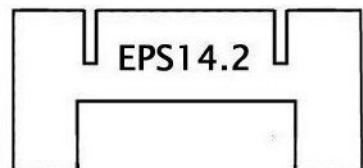
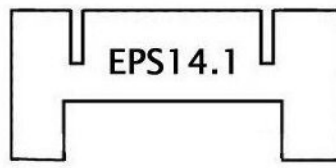
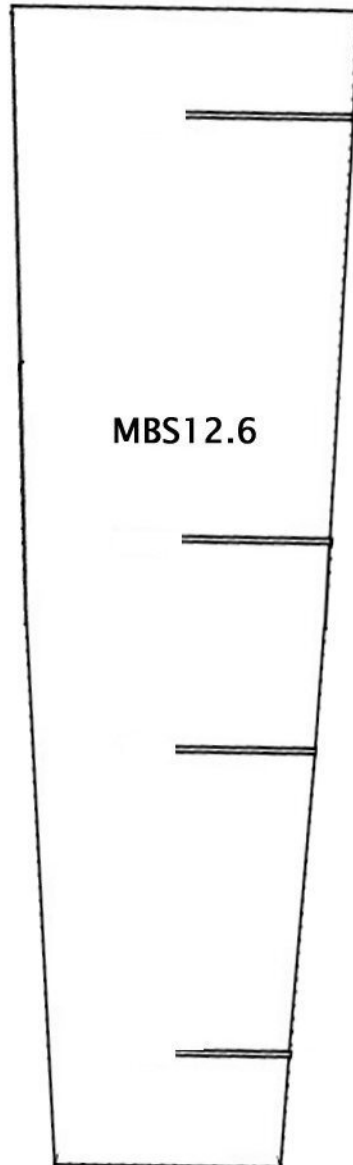
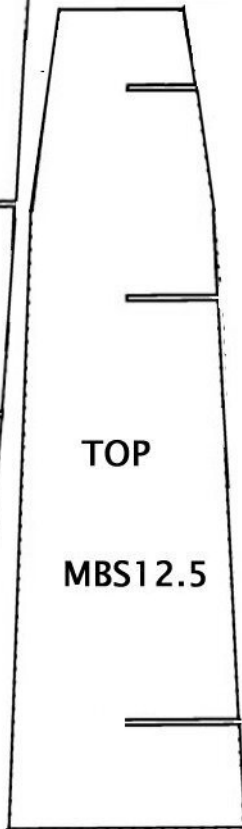
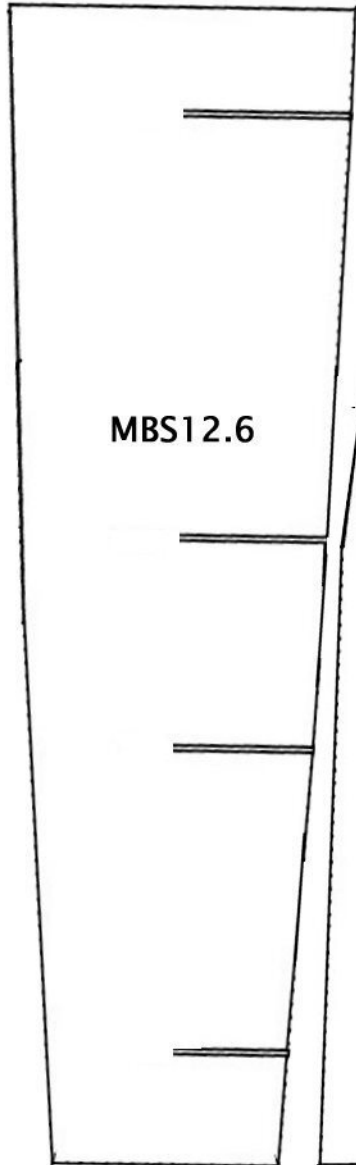
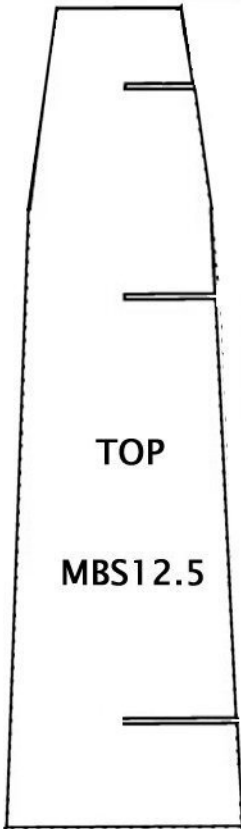
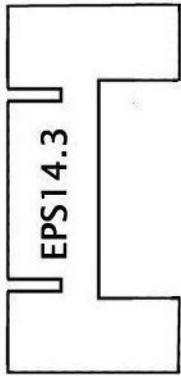
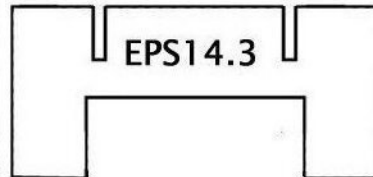
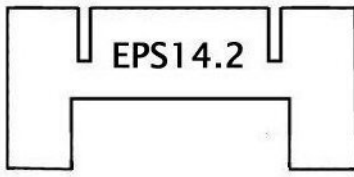
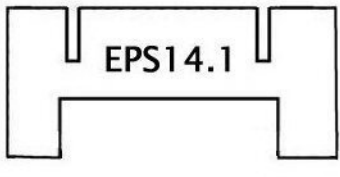
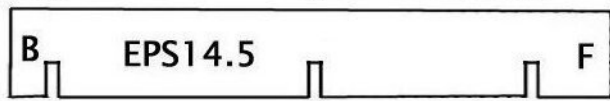
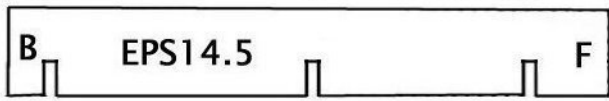
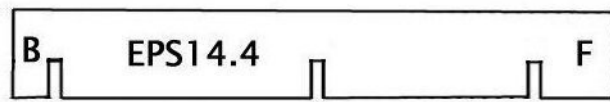
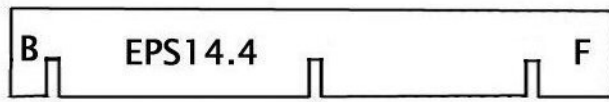

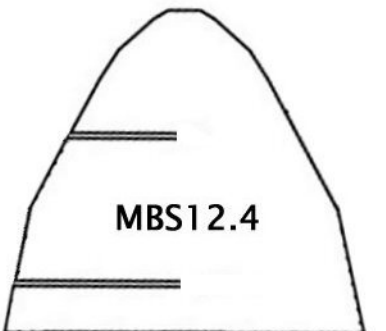
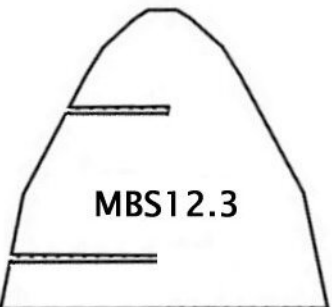
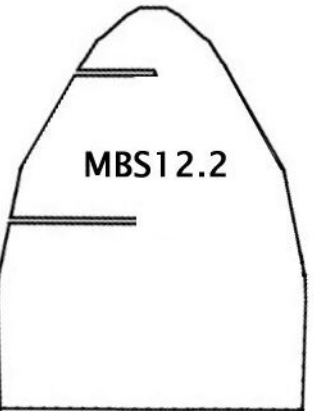
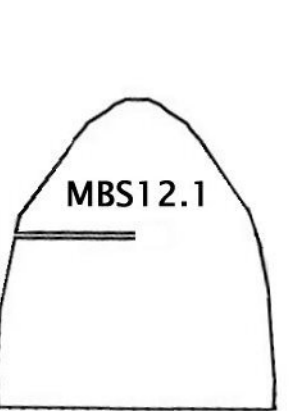
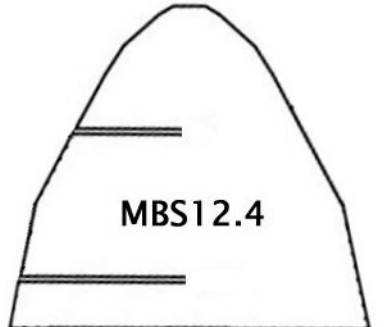
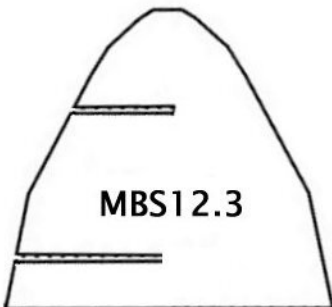
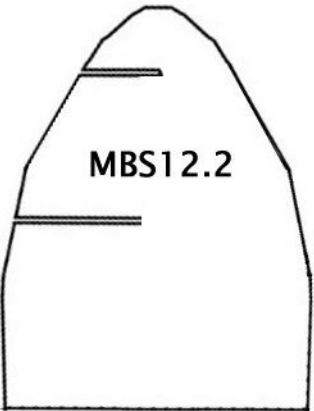
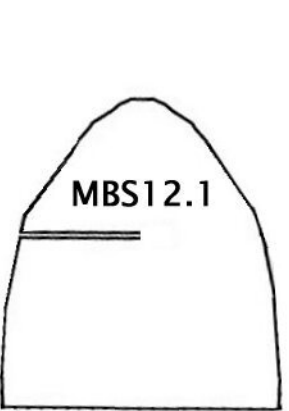
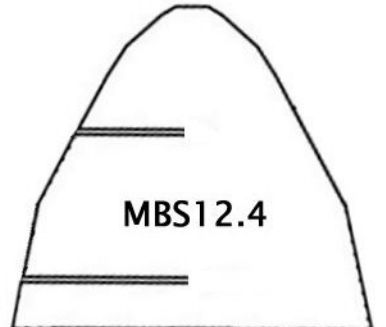
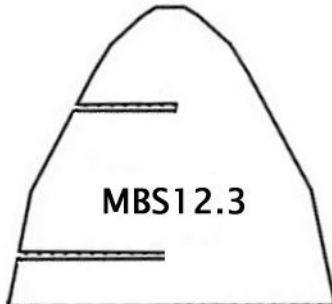
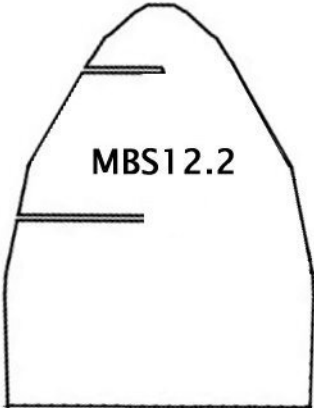
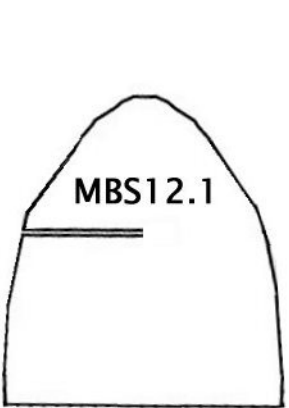
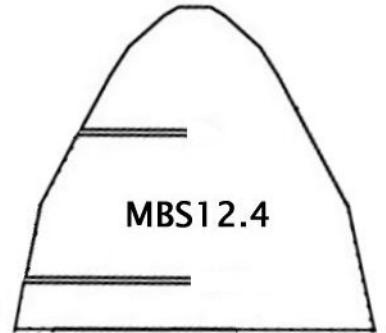
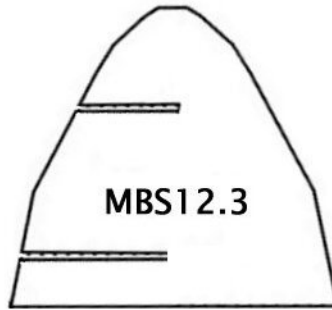
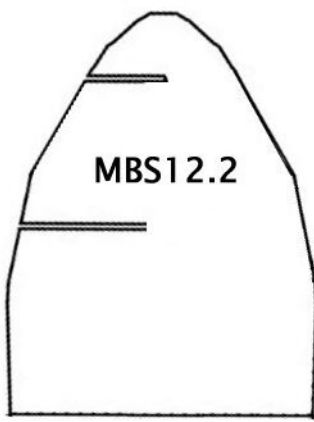
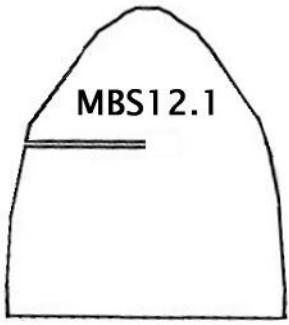

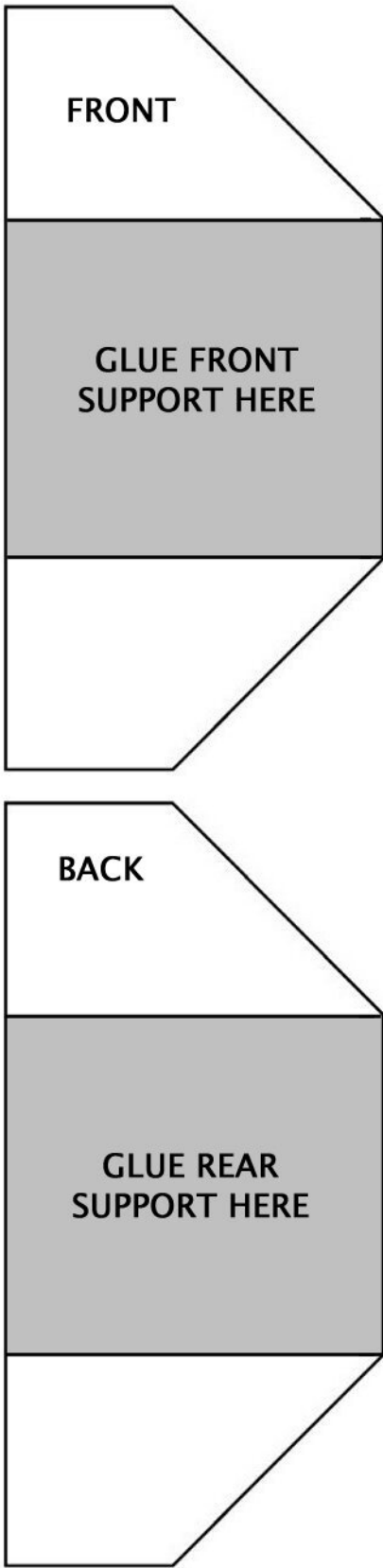

BOTTOM

RIGHT
NAMEPLATE 1

RIGHT
NAMEPLATE 2

STRUT LEFT

STRUT FRONT

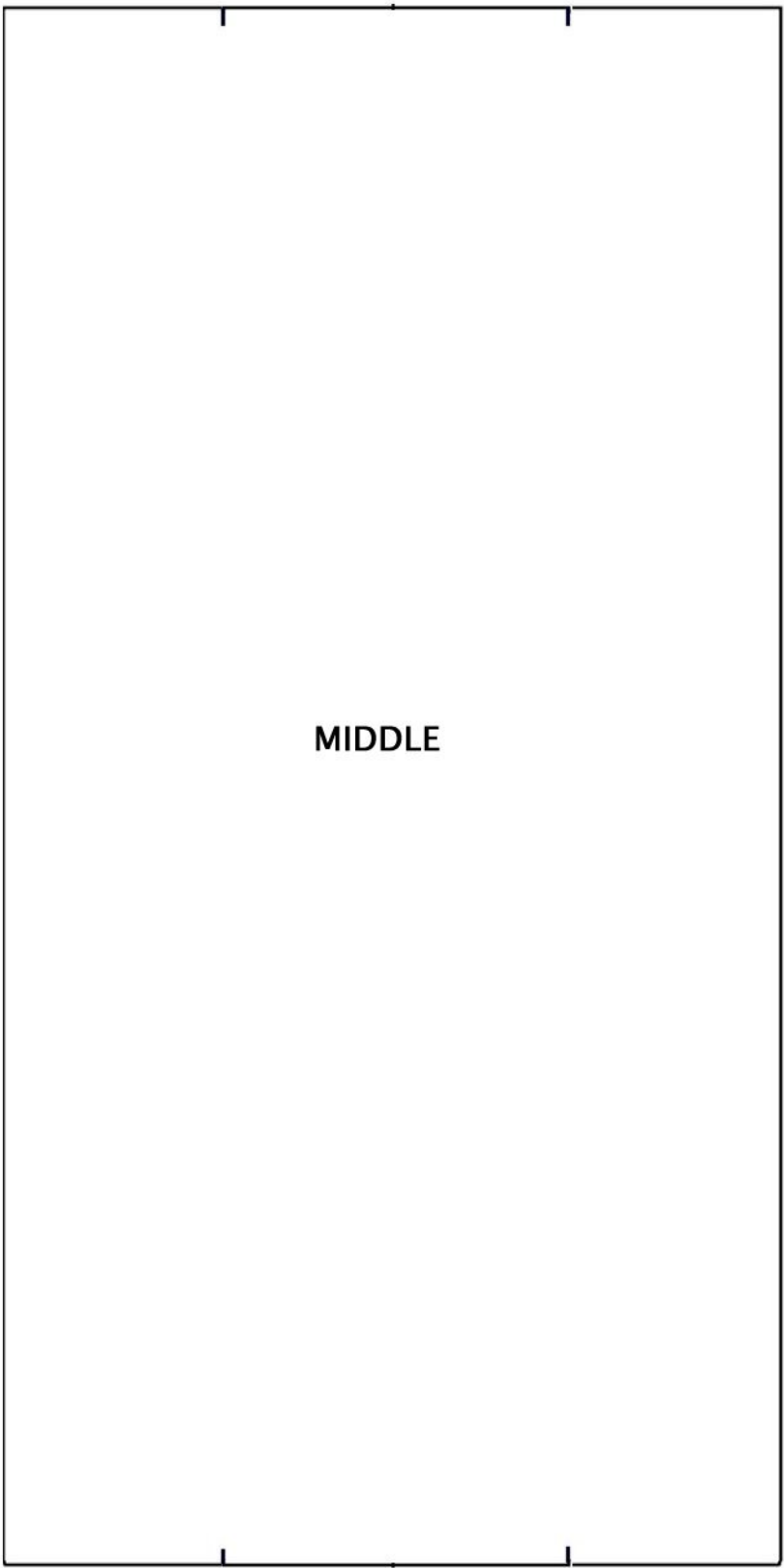

MIDDLE

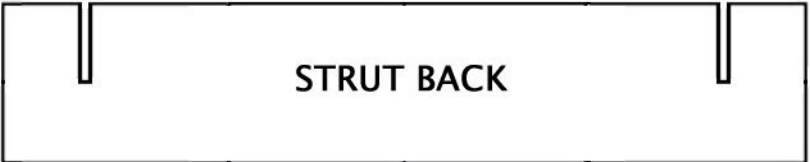

STRUT BACK



LEFT
NAMEPLATE 1



LEFT
NAMEPLATE 2



STRUT RIGHT

WICRIM DONNAGER

Class: MCRN Battleship

Length: 500M

Propulsion: 4x Epstein-Fusion Drive

Armament: 14x Torpedo Tubes (Plasma or Nuclear) 6fore, 8aft, 2x VX-12 Foehammer Ultra-Heavy Railguns, 59x Nariman Dynamics 40mm PDCs

Support Craft: 4 - 8 Patrol Destroyers or Frigates.

Crew: 2080



JOIN STRIP 4

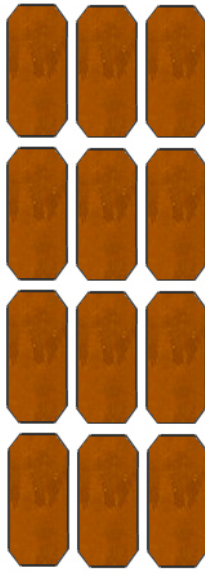

ENGINE JOIN STRIPS