

Bomben und Raketen für alle Flugzeuge

Bombs and rockets for all air craft

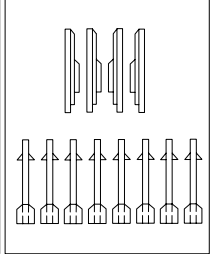
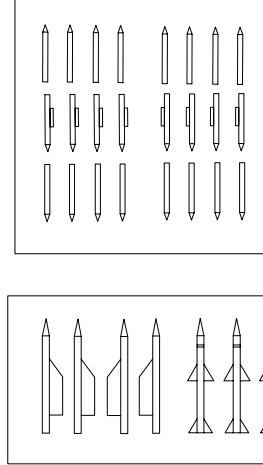
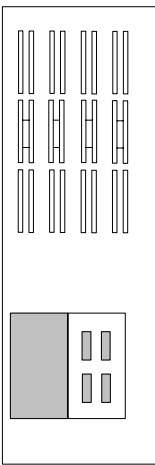
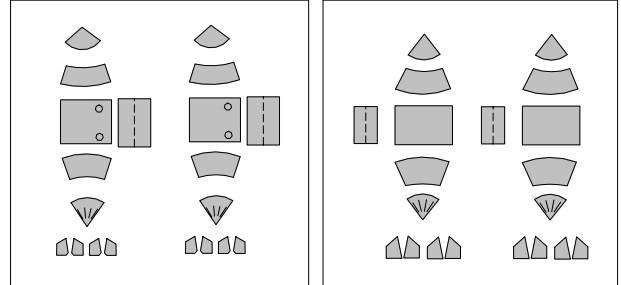

**Wilhelmshavener Modellbaubogen**  
 4 Bogen und Baueanleitung / 4 Sheets and Building Instruction  
**Flugzeuge für U.S.S. NIMITZ**  
 US Carrier Aiplane  
 Maßstab/Scale: 1:250  
 N. Dorn Design  
 (c)2004 Mbwe-Verlag KG, D-26382 Wilhelmshaven  
 Made in Germany

Bomben und Raketen für alle Flugzeuge

Bombs and rockets for all air craft

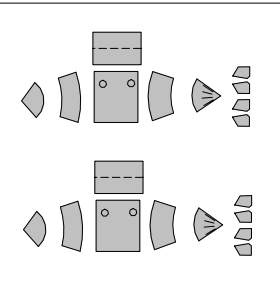
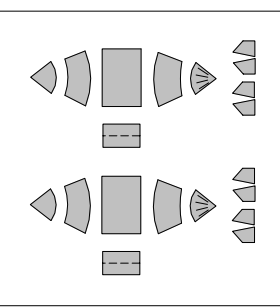

SEAHAK

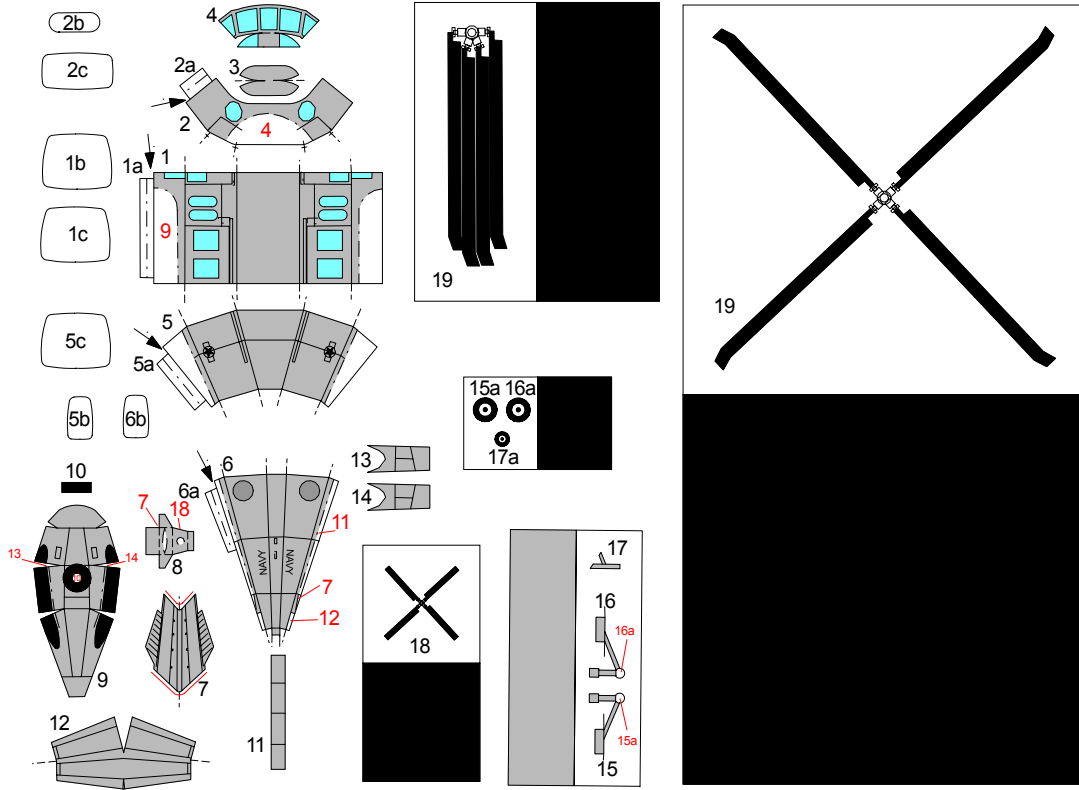

VIKING

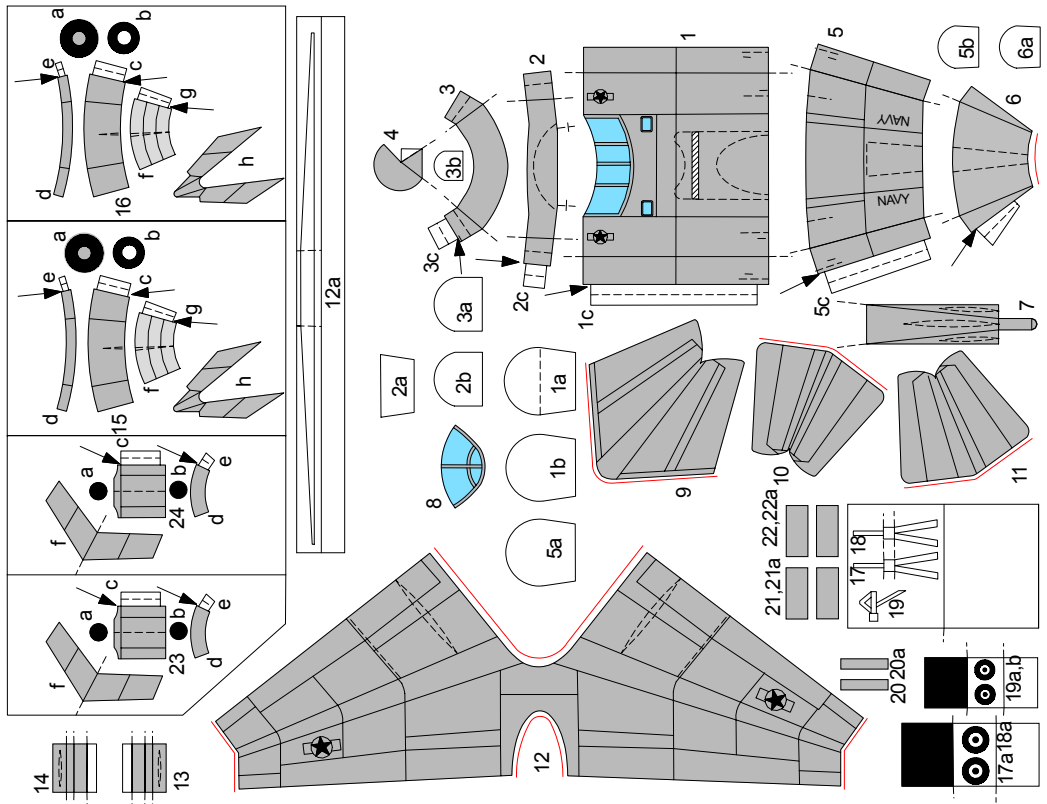

# JEMMYH

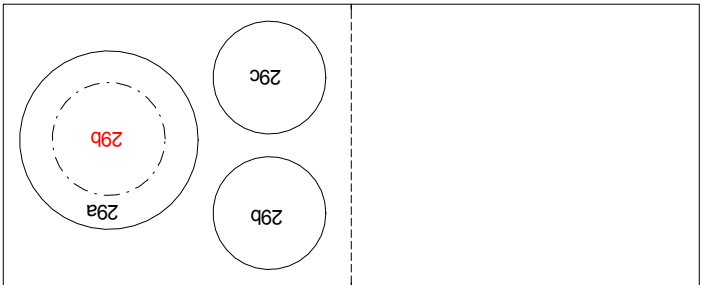
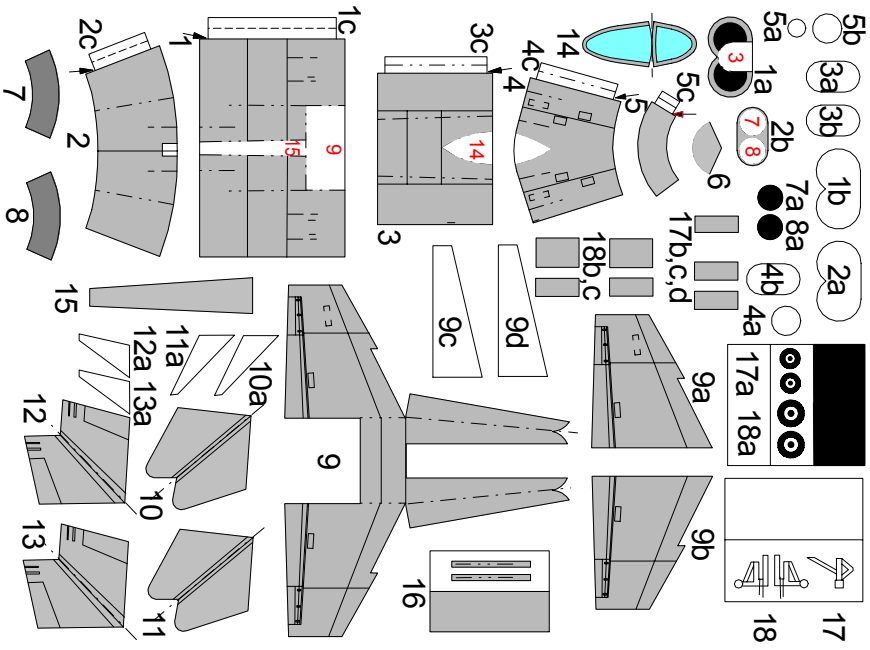

# HAWKEY

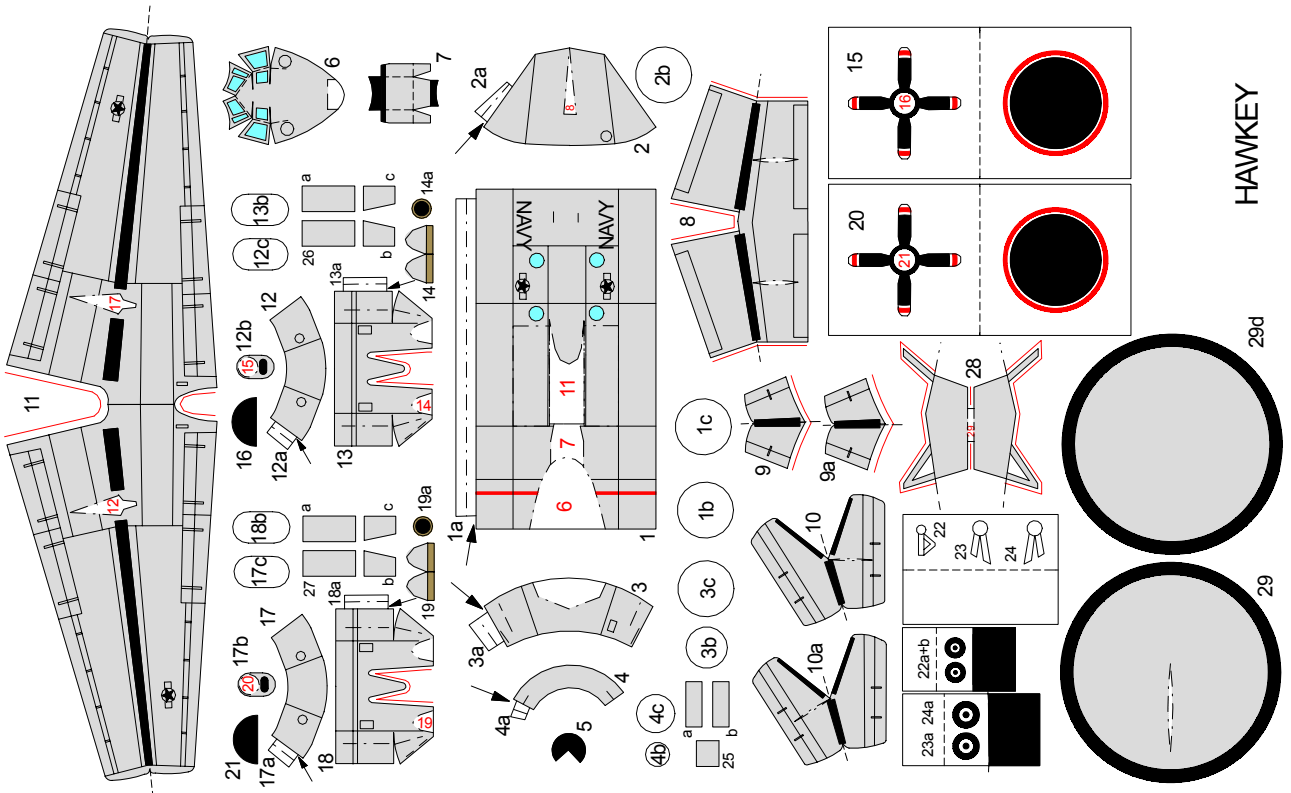

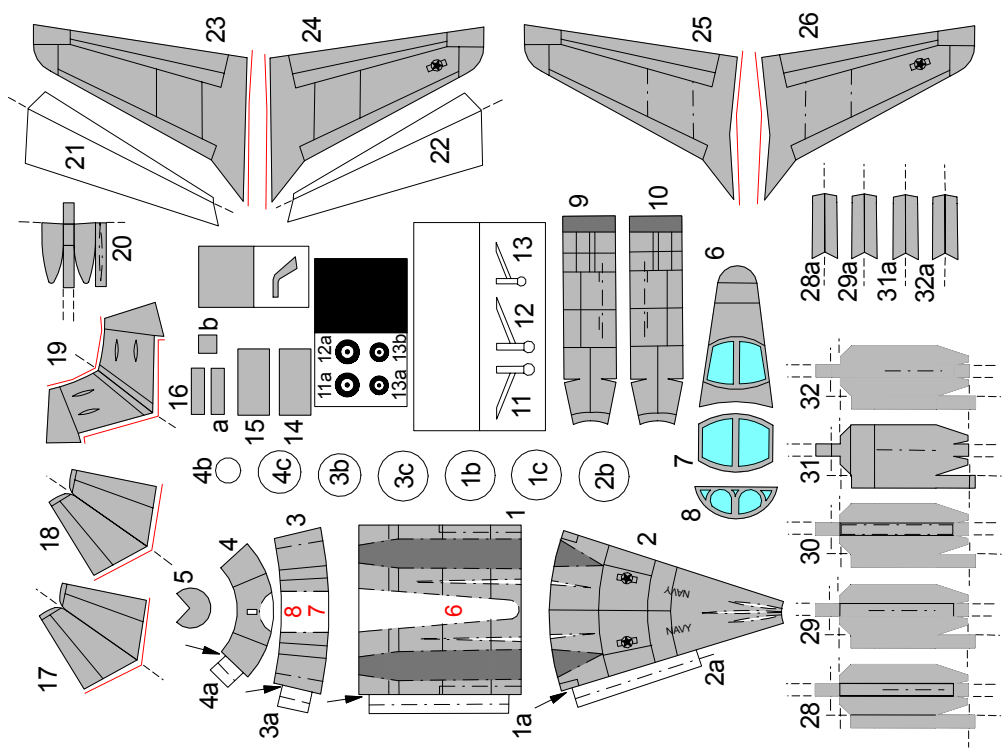

PROWLER

Zugwagen

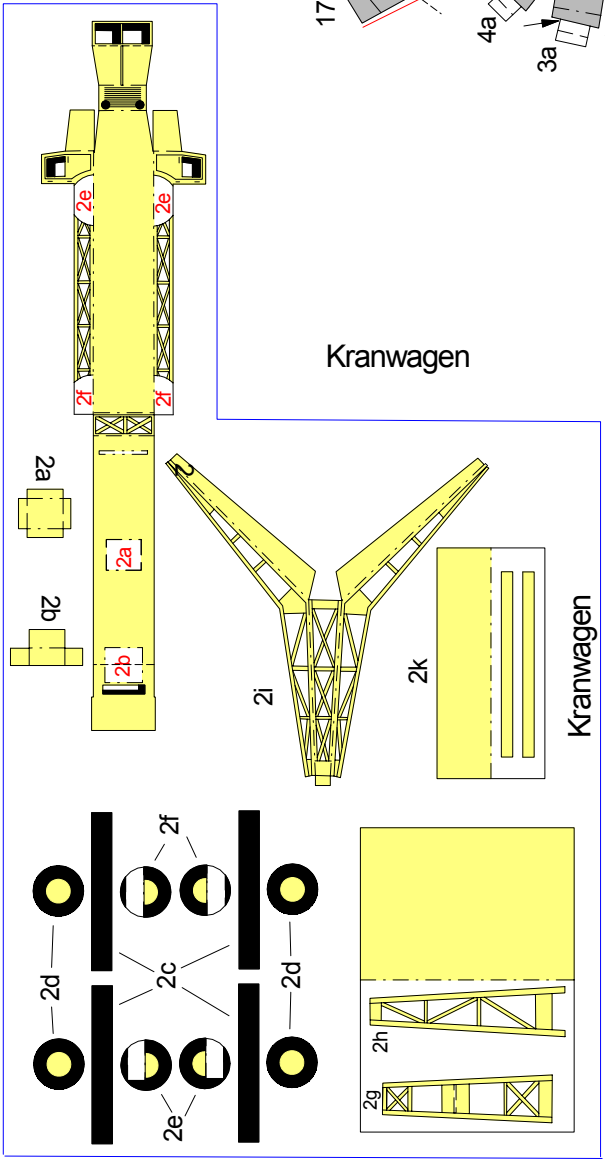

Kranwagen

Kranwagen

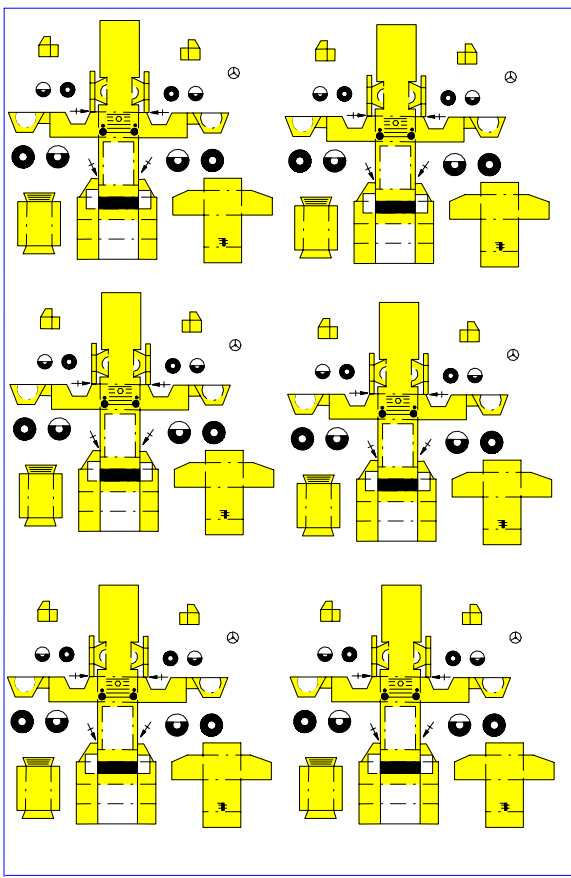

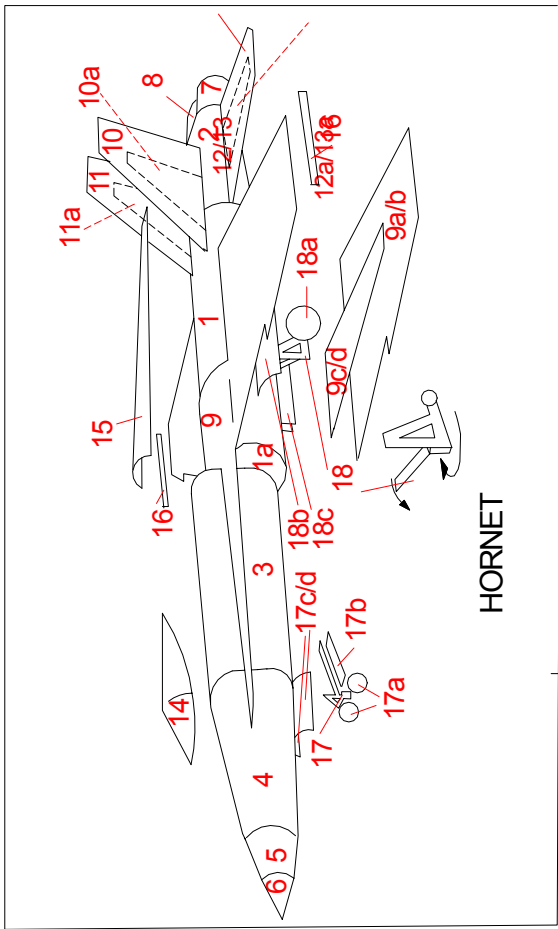

HORNET

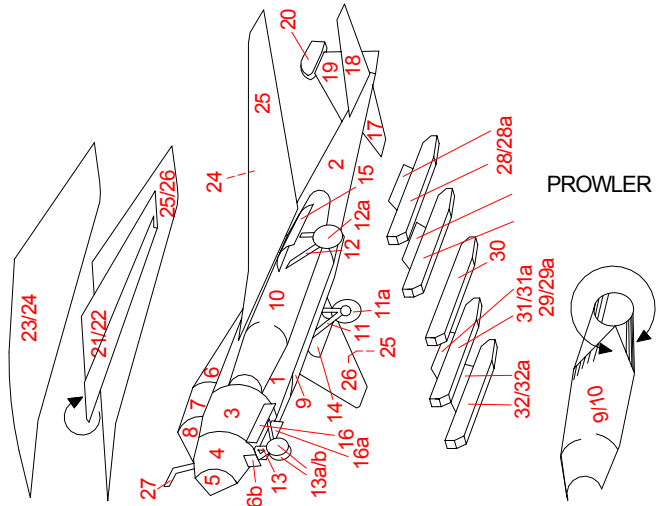

PROWLER

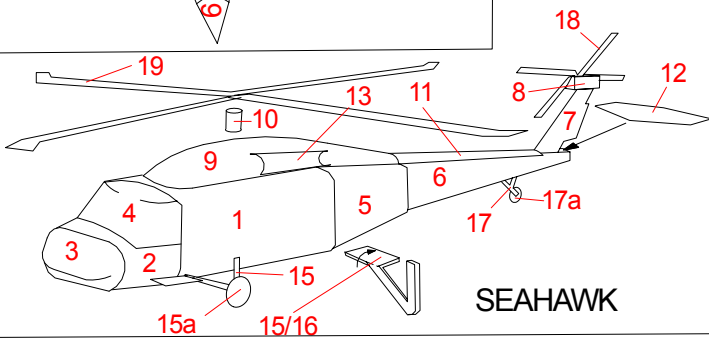

SEAHAWK

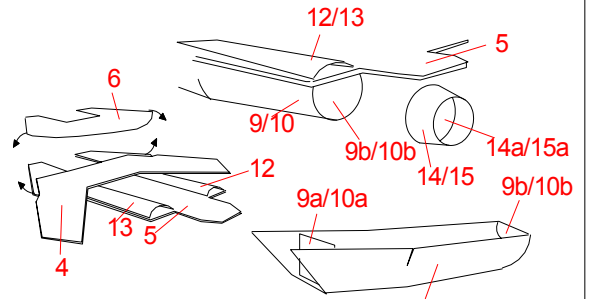

TOMCAT

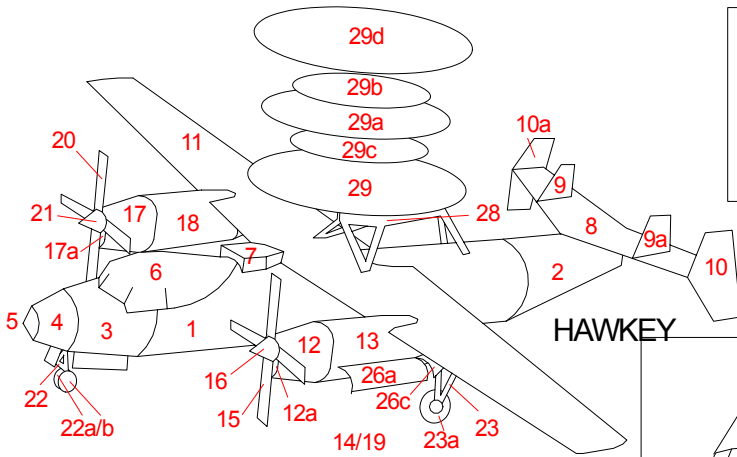
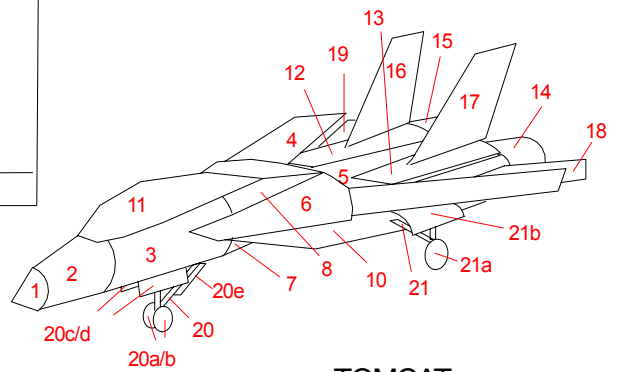

HAWKEYE

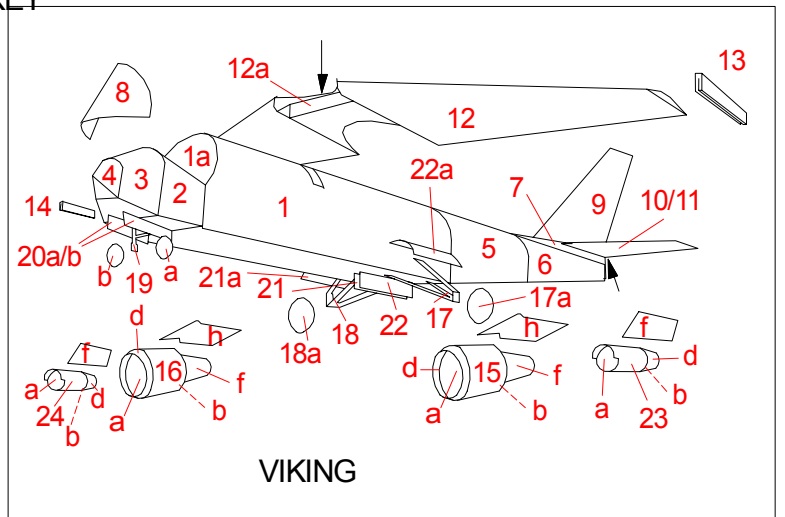
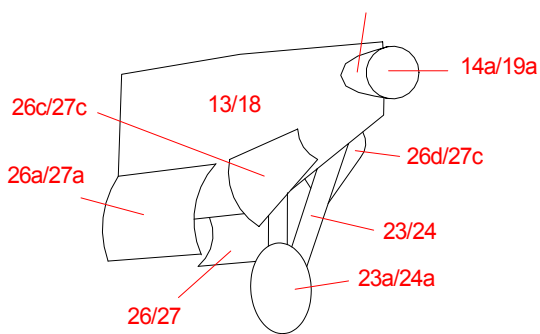

VIKING

# GENERAL INTRODUCTION FOR THIS MODEL WITH ONLY DIAGRAM-INSTRUCTION

Building this model with only diagram instructions can be just as easy if not easier than building a model with detailed step-by-step text instructions. There are three basic things to be kept in mind:

1. Read the following General Instructions very carefully to understand what the different markings / lines mean.
2. Before you start cutting-out, mentally assemble the model piece by piece to insure you understand the concept.
3. Refer to the diagrams as you assemble the model.

## THE ART OF MODELING WITH WILHELMSHAVEN PAPERMODELS

Building Wilhelmshaven card models is not difficult - it's just different from other forms of modeling and has its own methods. We would like you to find as much pleasure in the hobby as we do. Patience and precision are required, but with sufficient care the results are truly amazing.

### **What tools are needed?**

A basic tool kit is very inexpensive. You may find you have most of these items already.

1. *Hobby Knife*. For straight and curved lines.
2. *Scissors*. For curved lines. Small scissors with fine points are best.
3. *Cutting Board*. For protecting the work surface and prolonging the life of your knife blade.
4. *Blunt Edged Blade*. A steel ruler is ideal and an essential piece of equipment for guidance in scoring and cutting straight lines.
5. *Curling Tool*. For making curled shapes without creases you need a cylindrical object such as a knitting needle, a piece of dowel or a smooth pencil. For forming large cylinders we use a section of a broom handle.
6. *A Pair of good Tweezers* is handy for working with small parts.

7. *Selection of Felt Tip Pens*. For coloring cut edges and scored lines. Only buy as you need them so as to prevent unused pens drying out and becoming useless.

Other useful items to be found around the home are: a pin for pricking holes in the card, a needle for threading rigging etc., and paper clips or pegs for holding the parts together while waiting for the glue to dry.

### **A word about glue (cement).**

Water-free quick drying glue is best suited for assembly. Dry fit the parts, checking for alignment before applying glue. Use glue sparingly, wiping off any excess immediately.

Too much causes shrinkage and makes a mess. Once having gained experience most modelers will find that each adhesive has advantages for particular techniques as applied to the type of modeling.

All parts will fit together perfectly as each piece is tested for accuracy many times before it reaches the production stage. Some parts need to be doubled or even tripled for strength and rigidity (using scrap pieces from the sheets). They too must fit exactly. If too big, sand down the edges with a fingernail file. Before starting construction read the instruction from beginning to end and study the printed parts

so you will have a good idea of how everything is to go together. Build the model in your mind before cutting out any of the parts. This is all very well, but what if the instructions are in an unfamiliar language? After you have made a couple of models, you are unlikely to find this much of a problem.

The Wilhelmshaven card model is based on simple shapes; these being the box, the cylinder, the pyramid and the cone.

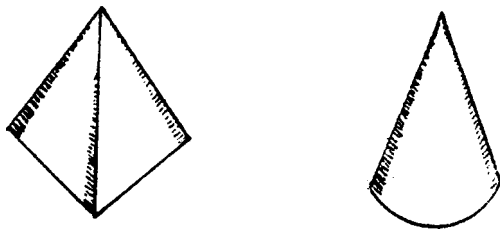
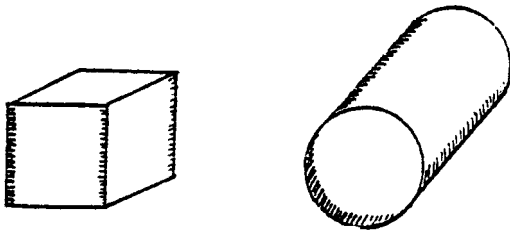

More complex shapes are built from combinations of the four basic shapes, and after you have gained a little experience you will be able to recognize what to do simply from the shape of the printed part.

Each WILHELMSHAVEN MODEL is an exact miniature of its original. This is achieved by using detailed construction plans and drawings of the prototype, color photographs and other data supplied by the shipyard or manufacturer. The colors are as accurate as they can be from the data available.

### Techniques

The construction follows a logical pattern. Therefore your most important instruction is the line code.

- straight lines mark where to cut,
- ..... dashed lines mark the location to be scored on the reverse side, to bend up,
- - - - - dash-dotted lines are fold lines, to bend down,
- - - - - dash-double-dotted lines are boundaries.

Arrows indicate where component parts have to be separated from each other:

- ▶ cut out or along the line,
- / ▶ cut as far as cross mark,
- ▶ cut half the thickness of the sheet,
- / ▶ cut half the thickness of the sheet to the transverse mark.

Cutting should be done exactly along the line. Straight lines can best be cut along a (steel) ruler using a cutter or a razor blade.

Score each part before cutting it out.

Cut out and assemble parts in strict numerical sequence.

If removing any part(s) of a specific group from the sheets, lightly pencil the number of the piece(s) on the unprinted side as a reference.

Check each part for fit and alignment before gluing in position.

To score a part on the unprinted (reverse) side hold it against a window pane in daylight using a small steel ruler, this applies only to those pieces marked for bending upwards.

The following letters appear on certain deck fittings, wing spars etc., to show the direction

- O = Ober = upper
- U = Unter = lower
- H = Hinten = rear
- V = Vorn = front.

The model is generally assembled in numerical order unless stated differently in the written

directions. However, economic printing requires that sequential parts are not always printed next to each other. But a clear numbering system makes them easy to find.

The black numbers are part numbers. The colored numbers indicate the attachment areas to which the corresponding black numbered parts are to be glued.

Joining edge to edge means that where two components fit together they join bluntly. Joining tabs are those parts of a component which are being used to tie straight edges (seams) together.

Joining rings are those joining pieces which are rounded with the component, to join up cylindrical or conical components.

For all joints which are made with joining rings care must be taken that the ring, after being cut out, is fixed in the same way as it was joined in the first place. After being rounded the projecting edge of the joining ring is to be pressed slightly inwards facing to the center of the cylinder or cone, so that the next piece can more easily slide into it.

A clean joint can be made if the glue is applied to the inner surface of the connecting piece instead of to the joining ring. Before bending an external component the fold line is to be scored with a blunt knife (or similar device), to avoid damaging the pattern. Before bending inner components, such as the former which fit inside wings or other contour-surfaces the fold lines should be cut half way through the sheet to obtain a clean bend.

To build rounded components, they should be pulled over an edge, such as the edge of a table.

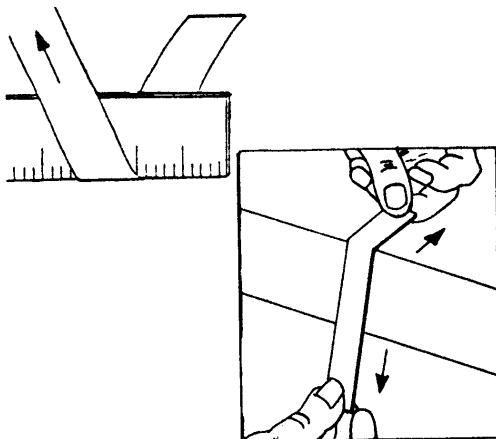

With an appropriate strong or gentle pull, a very even and smooth rounding to any desired diameter can be obtained. It can also be achieved by rolling

a round pencil or dowel over the component using a foam pad as rolling surface. The smaller the diameter of the dowel the smaller the diameter of the component. Very small parts such as landing gear or round masts may be "wrapped" around any item of similar diameter (nails, knitting needle etc.). Some practice is needed (e.g. with scrap) but careful rounding makes assembly easier. To form a cylinder roll the part around a piece of dowel, pencil etc. Very small pieces are best done against the tip of your finger.

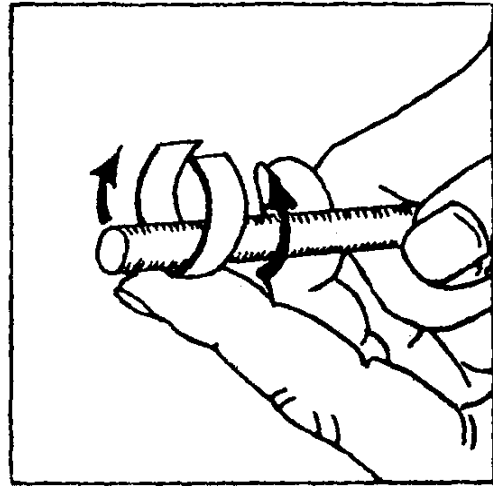

To form a cone use the same procedure as forming a cylinder, but keeping the point of the cone in the same position while forming the curve, i.e. a series of radiating bends.

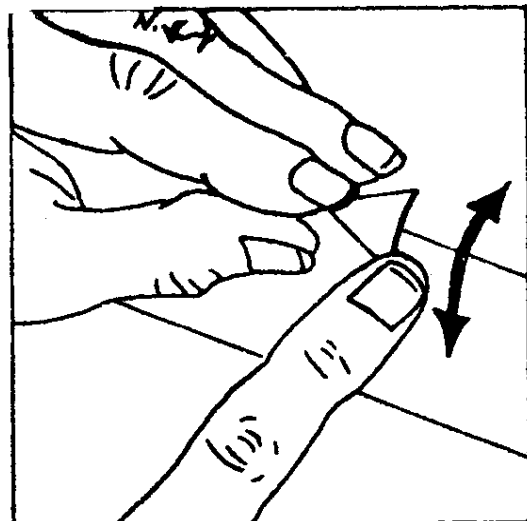

Small strips can be rounded by pulling them between a dull knife blade and the thumb, as one curls a ribbon.



## Ships

### Base Plate

If possible "pin glue" the base plate to an even surface of a pad. Use a minimum of glue and work quickly so that spots do not dry out before placing the base plate into position on the pad.

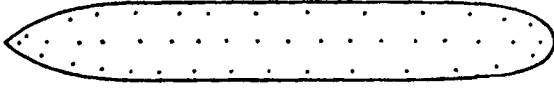

Press down gently to ensure that the base plate is completely flat as this is the key to all that follows including a warp-free construction. The model should be left in position on its baseboard until completed, at least until the hull, decks etc. are placed and glued in position. Then remove the model from the base-plate by sliding a steel ruler gently between the base plate and the model.

### Bulkheads

Cut out the section bulkhead.

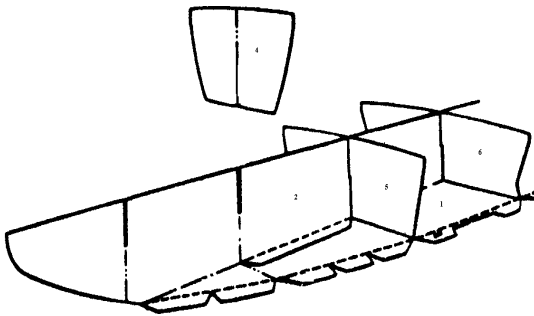

You may wish to use scrap for doubling it to increase the strength. They will fit perfectly and the finished model will be strong enough if used straight from the sheet. However, the structure can be made even stronger by laminating with off-cuts of soar sheet or alternatively made from 10 or 20 thou plastic card.

### Compound Curves

Some of the merchant ship models may have a stern or bow built in sections. Place the piece to be curved with the printed side down and gently rub with a warm teaspoon. After the parts have been worked into shape they can be more easily fit or glued into position. The work can further be facilitated by using splices of masking tape - sticking them at the inside of the joints: first glue gently the edges of the joints, wipe off the surplus and carefully stick the tape at the inside edge-to-

edge joints. Practice it first on some pieces of scrap before attempting this on a model! After the splice is dried out rub over the outside surface of the joint with a pencil, pen barrel etc. taking care not to shine up the printed surface.

### Detailed Railing, Ladders, Rigging.

Railing can be made from half staples joined by fine wire or from plastic spruce. Ladders can be made from plastic spruce or from prefabricated model fittings. Rigging is best made from plastic spruce.

### Bollards

The following method provides satisfactory results:

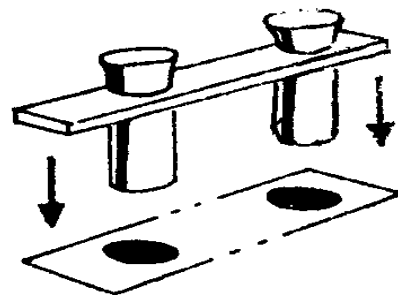

(a) before cutting out the marked part on the sheet place the base plate face up on a piece of soft wood. Center a needle into the circle indicating the bollard position and push through. Then work the needle around with a circular motion until all material within the circle has been "pushed" through to the reverse side. Repeat until all positions have been opened up.

(b) Turn over and with a sharp blade trim off the "wedges" that have been raised on the reverse (non-printed) side.

(c) Repeat step (a) on the deck position, opening up each circle as before. Obviously you cannot cut off the wedges but this is not important as they cannot be seen on the completed model.

(d) Get pins or small nails of suitable diameter and sand or grind the tops flat. Cut to about 1/4 in length.

(e) Cut an appropriate section from a scrap, push two pins through it, then cement the piece onto the deck and tap pins down to the desired height. Repeat until completed.

Having completed your model you will find that, although the ship has been built from thin cardboard it is remarkably strong. This strength

can further be increased by coating it with an acrylic spray. This can either be done at a sub-assembly stage or after completion. If the latter, do it before rigging. Several one shot "misting" are much more effective than two or three heavy coats. Practice on a piece of scrap first! By experience one can obtain a finish from mat to a high gloss.

## Aircraft

The design of the models is based on combinations of simple geometric shapes: the tube, the cylinder and the cone. Your success will depend upon the craftsmanship applied in building these simple constructions.

Cut out the section bulkhead. You may wish to use scrap to make it double thickness for added strength.

### Fuselage

Most fuselage construction of paper model airplanes is based on the progressive assembly of a series of cylinders and cones. They are built in ring-shaped sections, which are joined end to end: one section fits over the flange of next.

To give the fuselage shape and strength, bulkheads are fitted into the sections. All bulkheads must be strengthened by doubling their thickness with an additional of paper. On the model sheet, the fuselage sections are laid out in logical order and you can visualize how they go together. Once they are cut out, this order is lost. To avoid confusion, you should work on only one section at a time. Mark the part number and the direction of orientation on the back of the parts after they are cut out. Think about how the fuselage is assembled from many different parts. They are precisely engineered to fit exactly on and into each other. You can build a fine-looking model if you work with care, by making careful

cuts with a sharp blade and by being patient and neat when fitting parts together.

### Wing

Add strips to spar assemblies as required to smooth the airfoil curve. Progressively contour wing and tail surface skins using a tapered rounded edge over a rubber or plastic sponge pad.

### Cockpit

Windows and glass areas on aircraft may be glazed with thin cellophane.

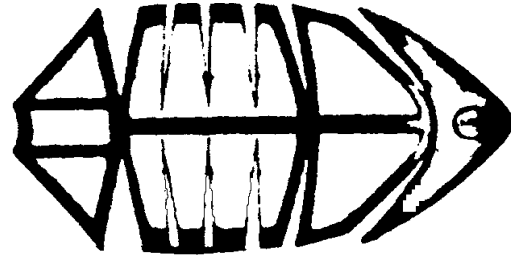

Cut out the cockpit frames leaving an excess surround of card. Then with a very sharp blade remove the printed "Glass" area. Apply glue, making sure that it is everywhere on the frame which will come in contact with the transparent material. Wipe off any excess glue and put in place the transparent foil. Turn over quickly and with a toothpick etc. Carefully press down along pillar, cabin edges etc. to ensure a good joint. When thoroughly dry, trim off excess card, curve gently to shape and fit into position.

Apart from building a model straight from the sheet there is ample opportunity for super detailing, mixed constructions using different material up to and including prefabricated parts available in your hobby shop.

**Enjoy your Wilhelmshaven Model  
building experience!**