

## CREATIVE PARK

<http://www.canon.com/c-park/en/>



View of completed model

### Assembly Instructions : Three A4 sheets (No. 1 to No. 3)

\* Build the model by carefully reading the Assembly Instructions , in the parts sheet page order.

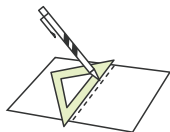

\*Hint: Trace along the folds with a ruler and an exhausted pen (no ink) to get a sharper, easier fold.

### Assembly Instructions



**Mountain fold(dotted line)**  
Make a mountain fold.



**Valley fold(dashed and dotted line)**  
Make a valley fold.



**Scissors line(solid line)**  
Cut along the line.



**Cut in line(solid line)**  
Cut along the line.

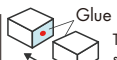

**Glue**  
The glue spot(colored dot) shows where to apply the glue.

**Red dot**  
Glue parts with the same number together.

**Green dot**  
Glue within the same part.

**Blue dot**  
Glue to the rear of the other part.

**Tools and materials**



Scissors, set square, glue(We recommend stick glue), pencil, used ballpoint pen, toothpicks, tweezers, (useful for handling small parts)

**Assembly tip**



Before gluing, crease the paper along mountain fold and valley fold lines and make sure rounded sections are nice and stiff.

**Caution**



Glue, scissors and other tools may be dangerous to young children so be sure to keep them out of the reach of young children.

Before starting assembly :  
Writing the number of each section on its back side before cutting out the sections is highly recommended.  
(\* This way, you can be sure which section is which even after cutting out the sections.)

→ Indicates where sections should be glued together.

We recommend using Matte Photo Paper and wood glue.

### Assembling the Easter Bunny

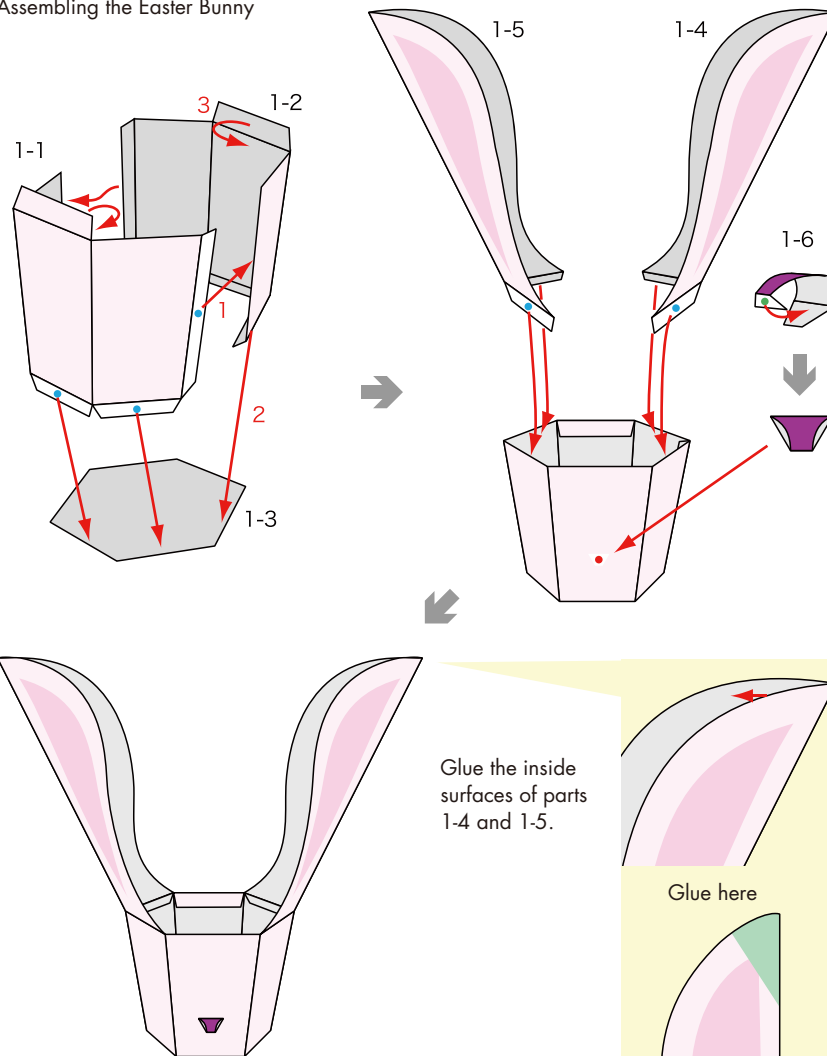

# Easter : Bunny Egg Holder : Assembly Instructions

## Assembling the ribbon

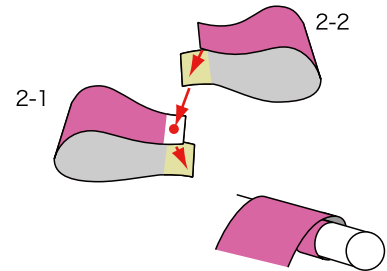

Wrap this part around a round pencil or other such cylinder to make it assume a curve.

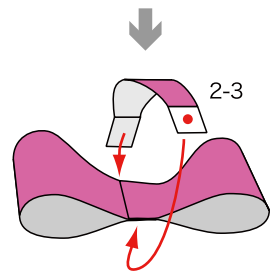

Glue the rear sides of the dots first.

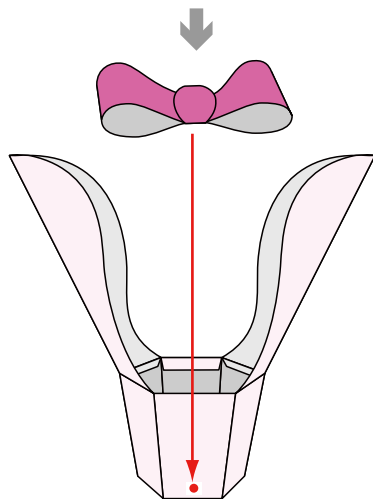

Glue the ribbon to the Easter Bunny.

## Assembling the lid

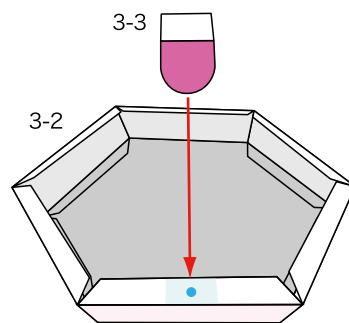
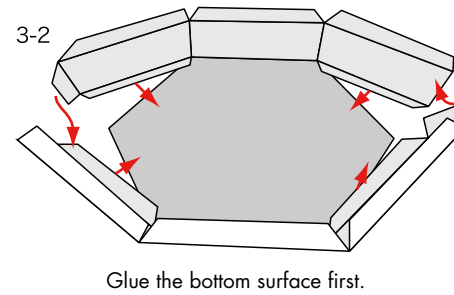
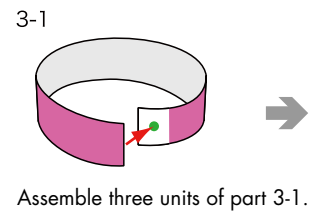

Glue the rear side of part 3-3.

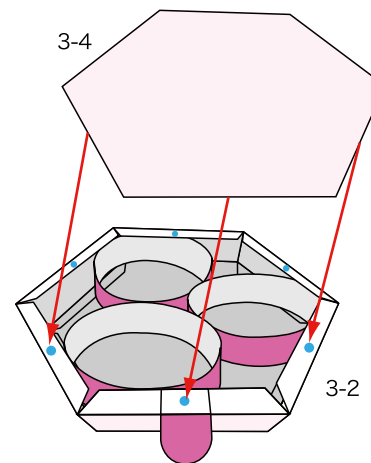

Glue part 3-4 into place after inserting parts 3-1 into part 3-2.



The lid is complete!

## Assembling the egg holders (three in all)

The egg holders differ in color only. Each is assembled in the same way.

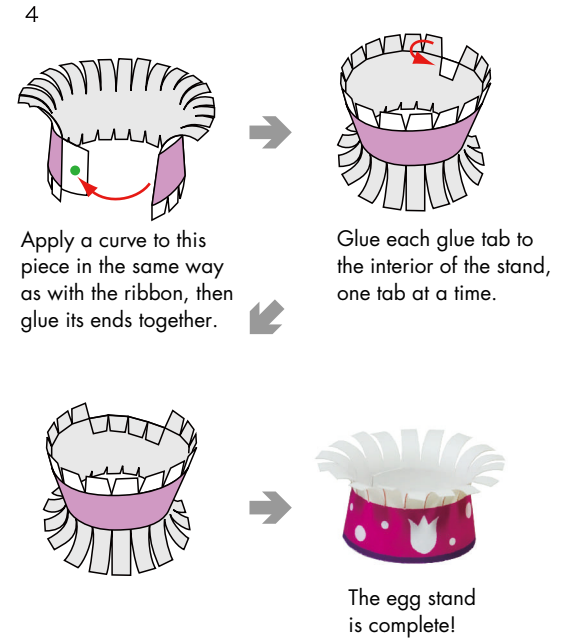

Apply a curve to this piece in the same way as with the ribbon, then glue its ends together.

Glue each glue tab to the interior of the stand, one tab at a time.

The egg stand is complete!

## Assembling the chicks (three in all)

Although the shapes and illustrations of each chick differ slightly, each one is assembled in the same way.

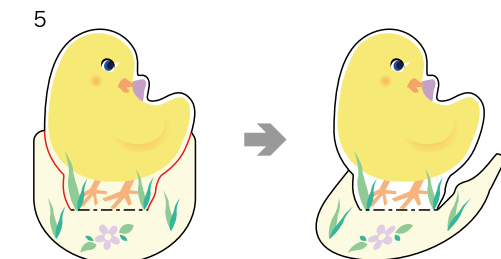

# Easter : Bunny Egg Holder : Assembly Instructions

Assembling the Easter eggs (six pieces in all : three lids and three bases)

Although parts 6-1 and 6-2 differ in size and pattern, the assembly method is the same.

6-2

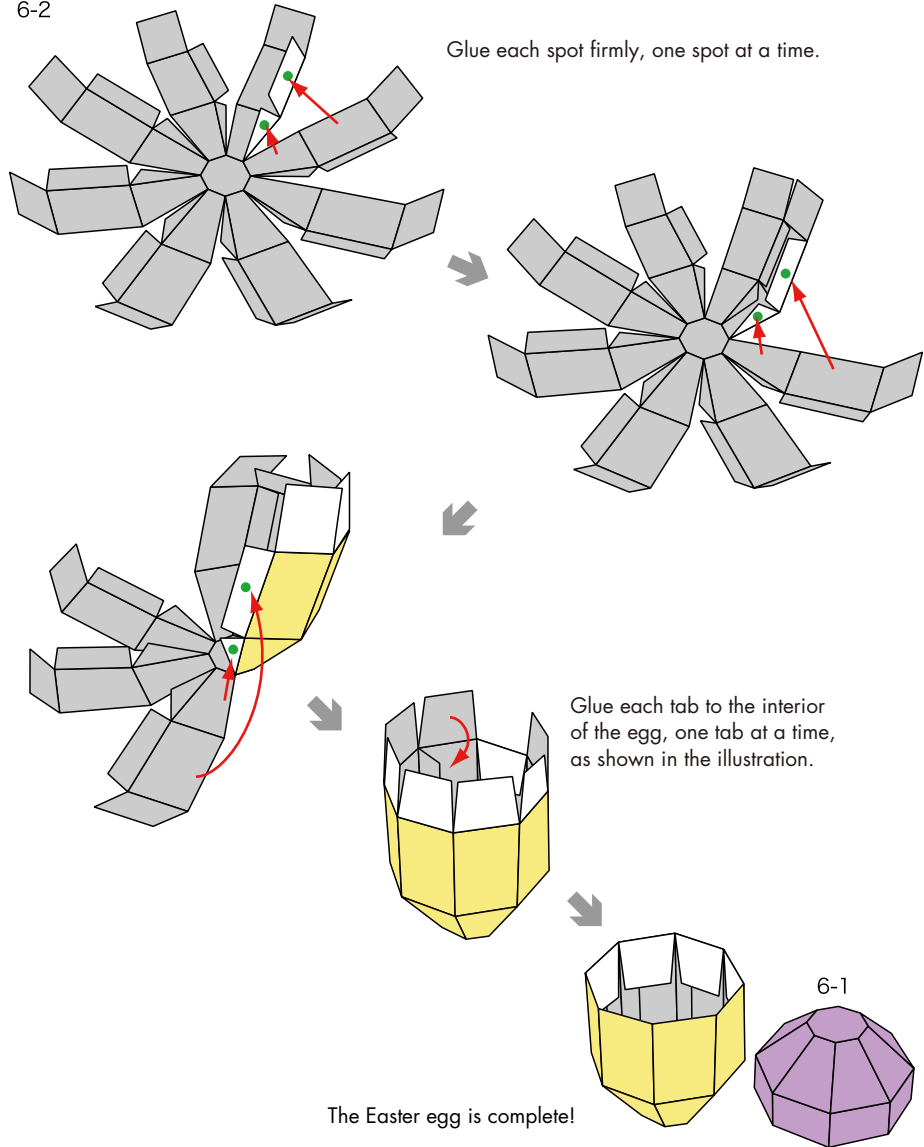

Arrange the Easter Bunny box, the egg holders, the Easter eggs, and the chicks in the way you find most pleasing. You can also use this model to hold real Easter eggs.

