

PAPER CRAFT

<http://www.canon.com/c-park/en/>



You will need

Scissors, glue, a used ball-point pen

Assembly Tip

Trace along the folds with a ruler and a used pen (no ink) to get a sharper, easier fold.

Caution

Glue, scissors and other tools may be dangerous to young children, so be sure to keep them out of the reach of young children.

Notation Key

----- Mountain fold

- - - - - Valley fold

———— Scissors line

———— Cut in line

● Glue

● Glue reverse side

Assemble the BOX 1

1 Glue the outer flaps of the side panels.

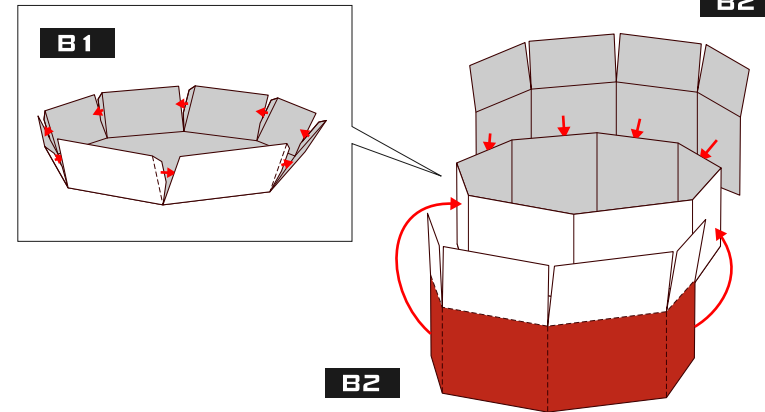

2 Make the outer box.

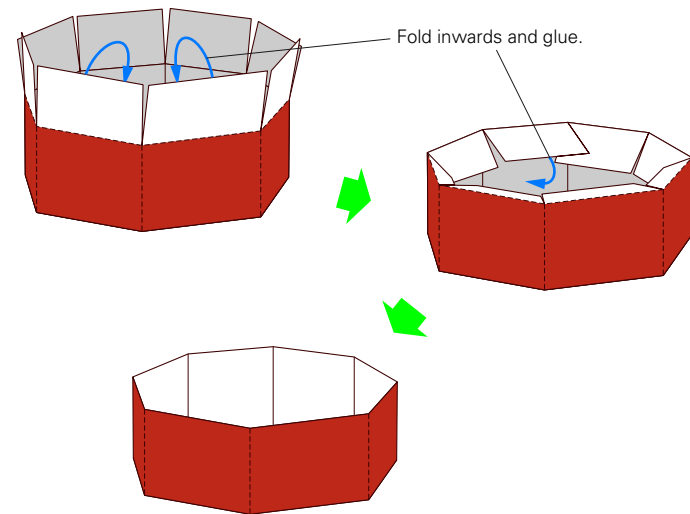

Assemble the BOX 2

1 Make the inner box.

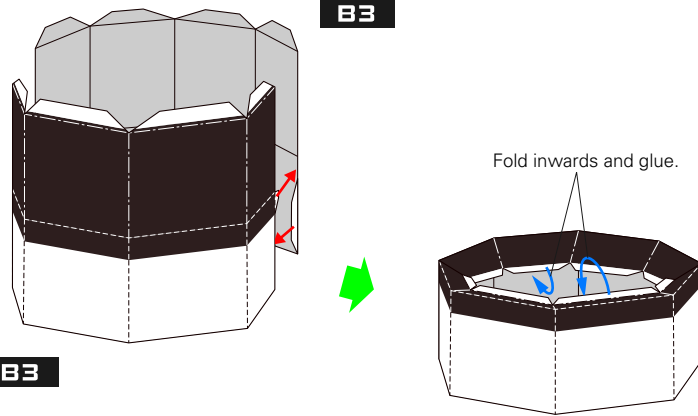

2 Assemble the box.

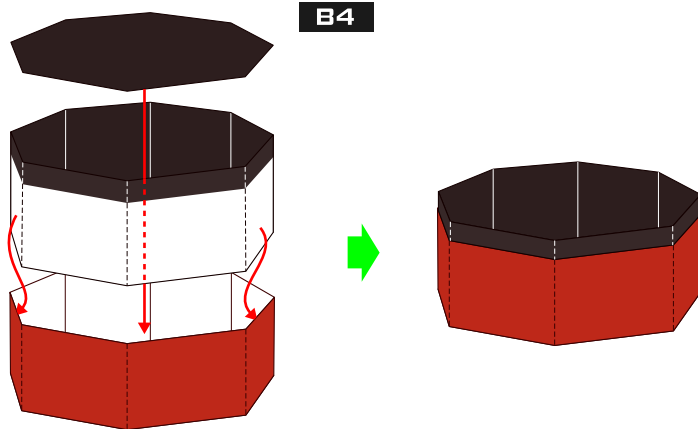

Assemble the LID

1 Make the lid.

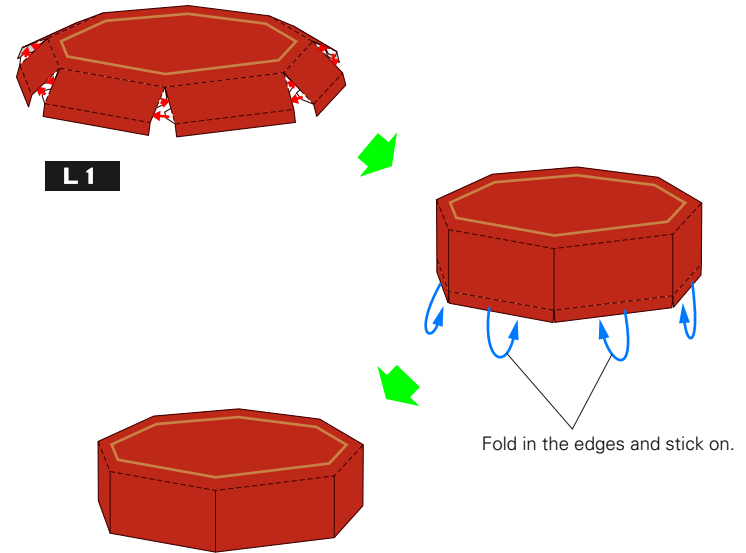

2 Put on the lid and the box is complete!

