

★ For best results use 80 gr/m² special coated paper If you have ink jet printer
 ★ For best color matching use color reference tables for printer calibration

★ Use border scales to control the dimensions of the printed layout
 ★ Print the layout with maximal available resolution

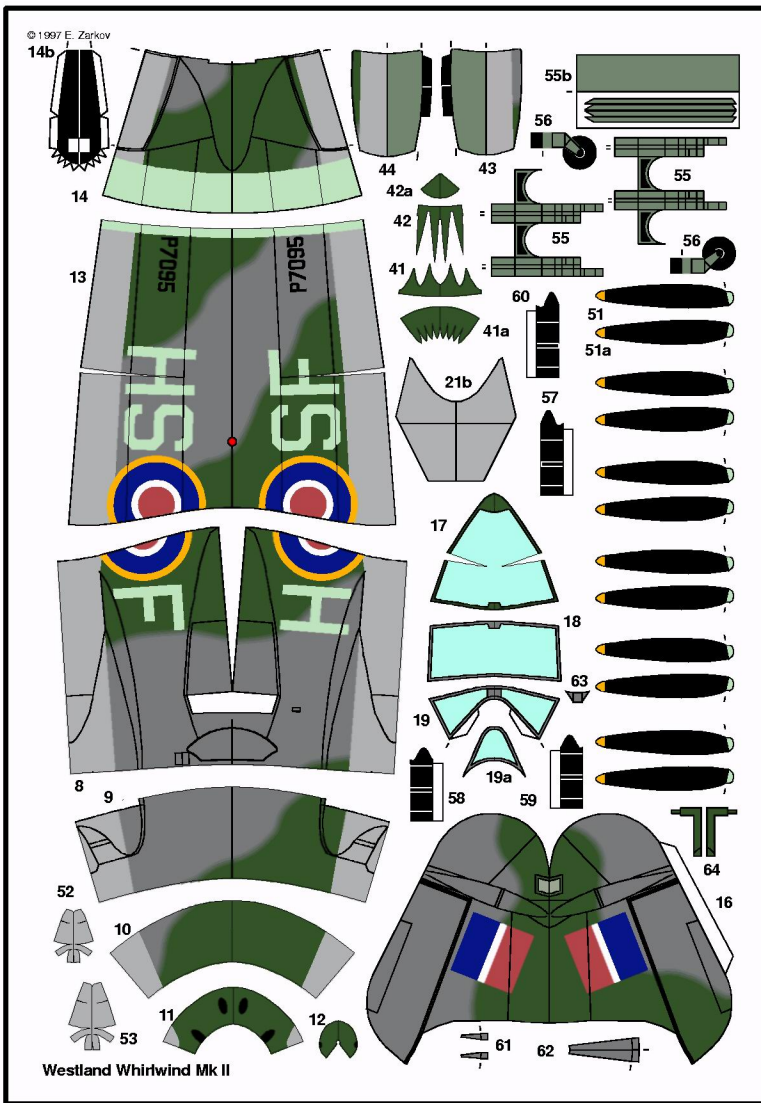

Scale 1:72

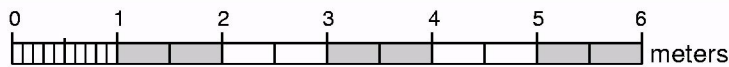

★ For individual use only, under no circumstances can this document be resold without written permission by ModelArt.
 ★ You can contact us sending E-mail to: modelart@sf.icn.bg



★ For best results use 80 gr/m² special coated paper If you have ink jet printer
 ★ For best color matching use color reference tables for printer calibration

★ Use border scales to control the dimensions of the printed layout
 ★ Print the layout with maximal available resolution

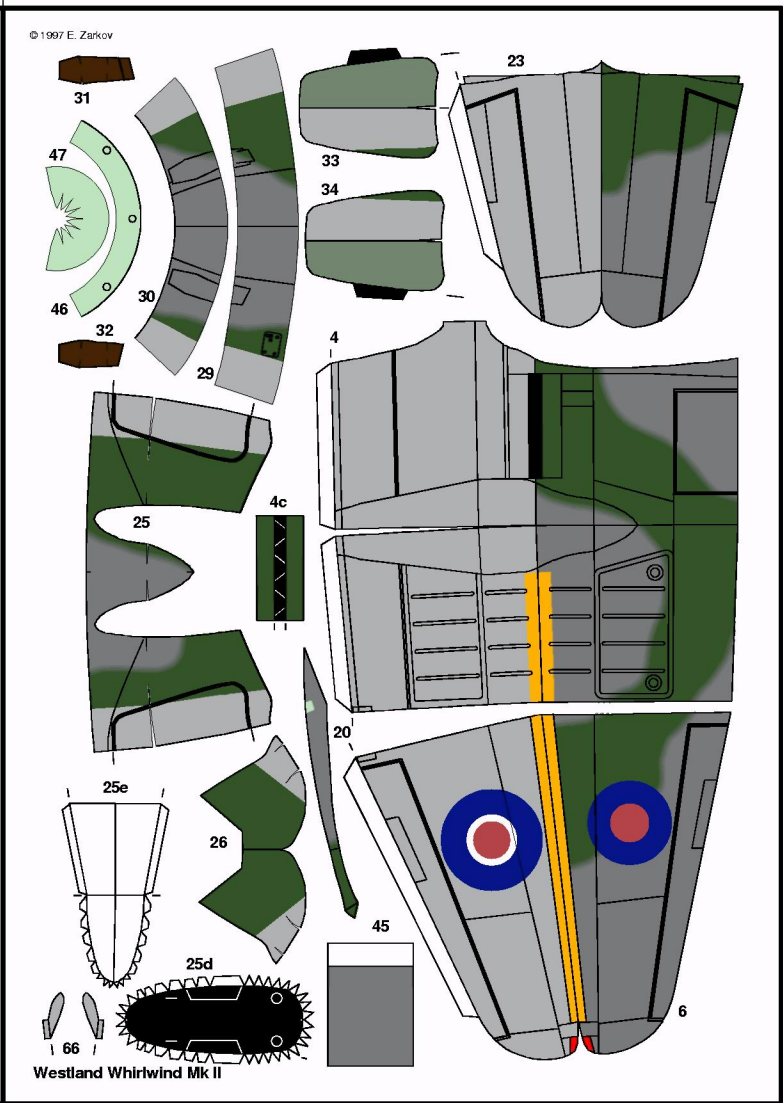
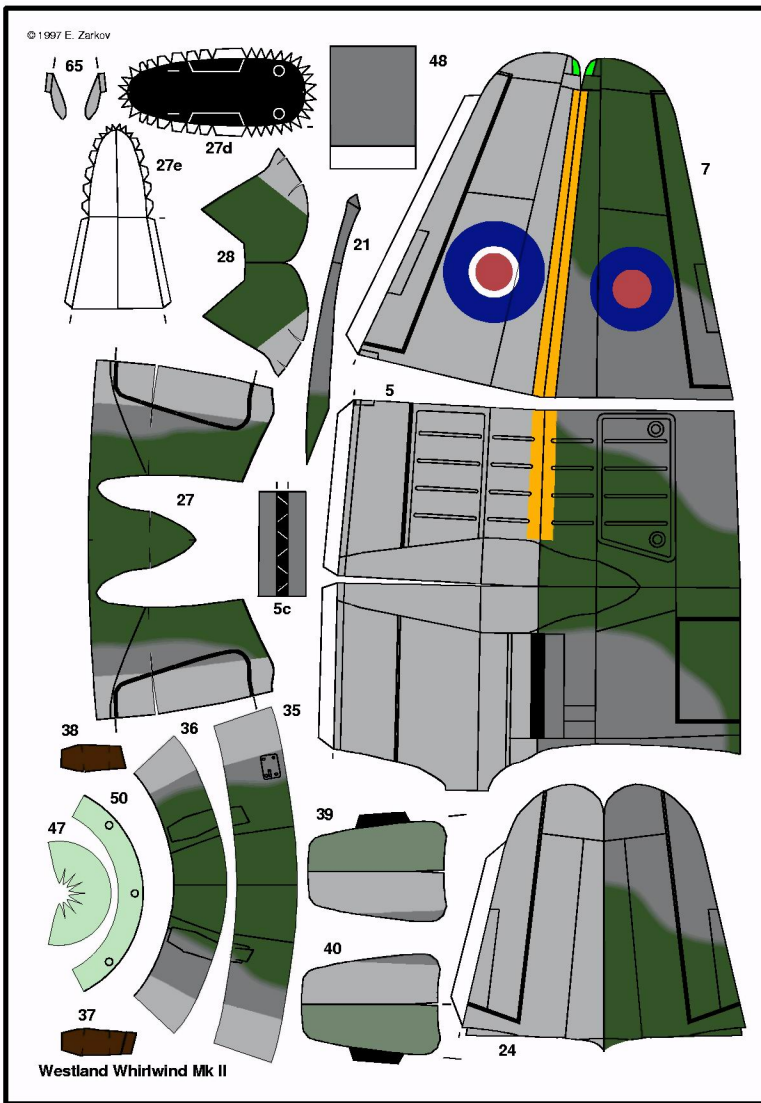

Scale 1:72

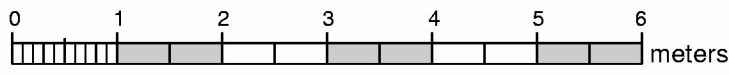

★ For individual use only, under no circumstances can this document be resold without written permission by ModelArt.
 ★ You can contact us sending E-mail to: modelart@sf.icn.bg



★ For best results use 80 gr/m² special coated paper if you have ink jet printer

★ Print the layout with maximal available resolution

Page 3 of 7

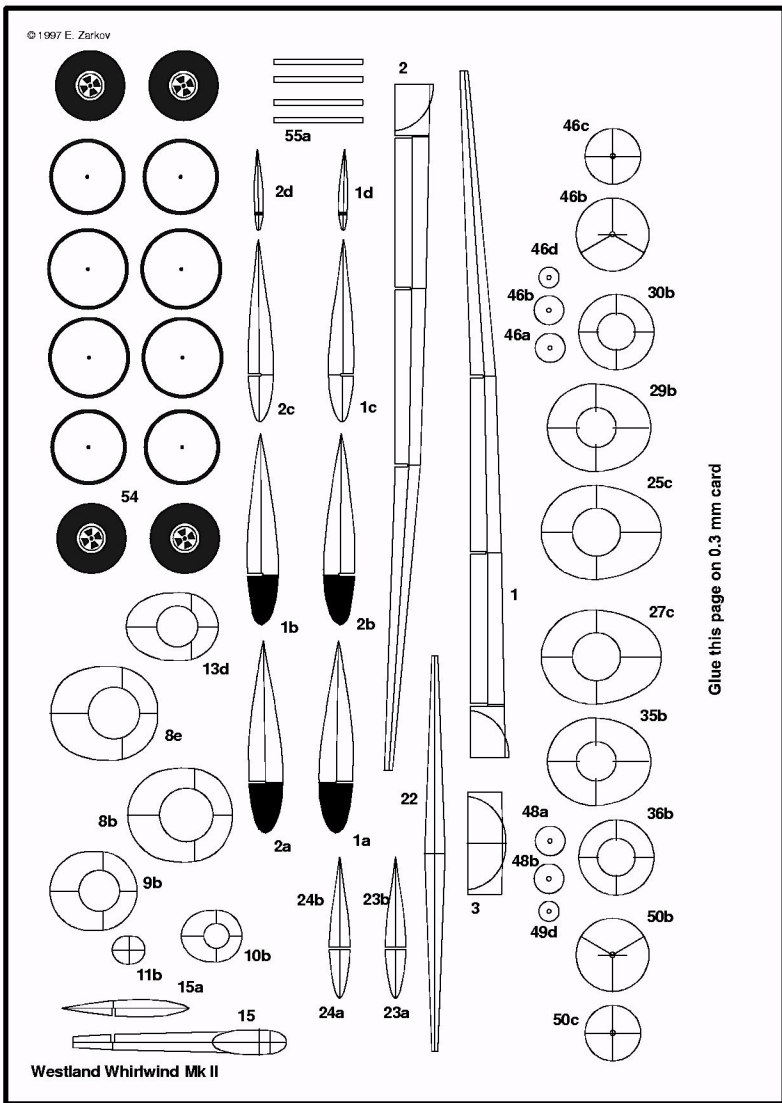

Glue this page on 0.3 mm card

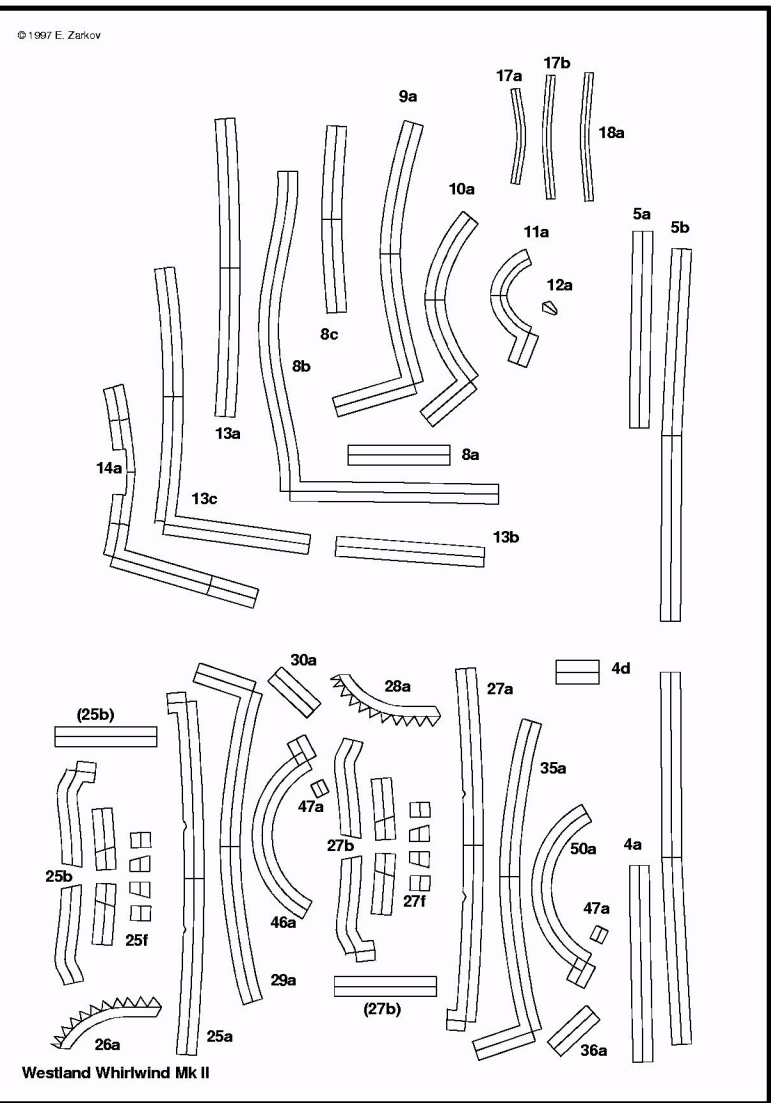

Scale 1:72

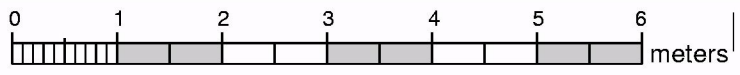

★ For individual use only, under no circumstances can this document be resold without written permission by ModelArt.
★ You can contact us sending E-mail to: modelart@sf.icn.bg



© 1997 E. Zarkov

ASSEMBLY INSTRUCTION

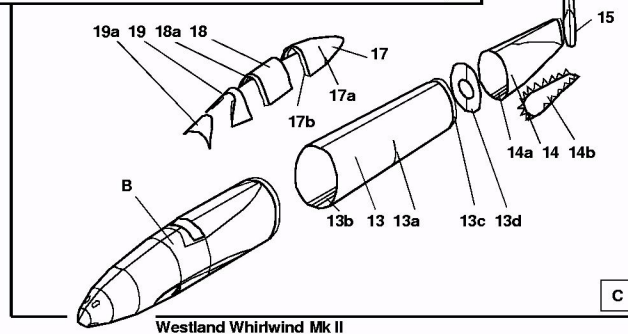
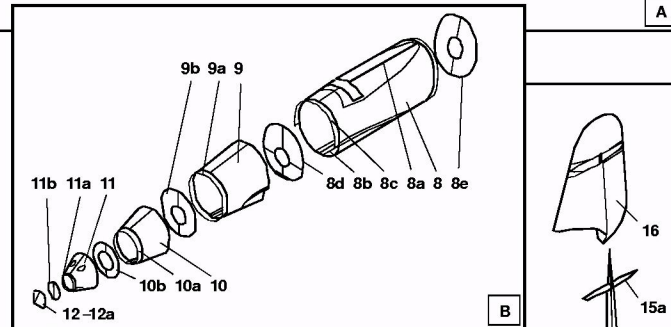
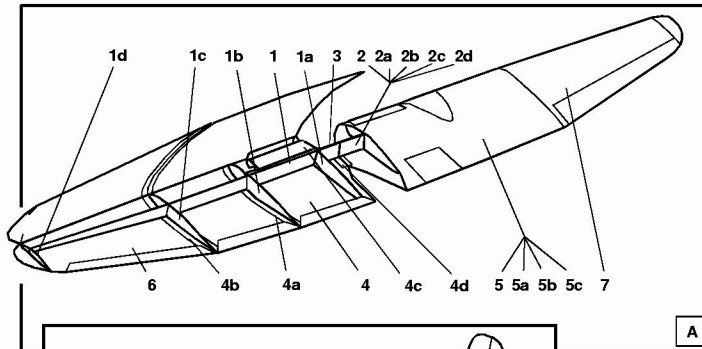

Westland Whirlwind Mk II

© 1997 E. Zarkov

ASSEMBLY INSTRUCTION

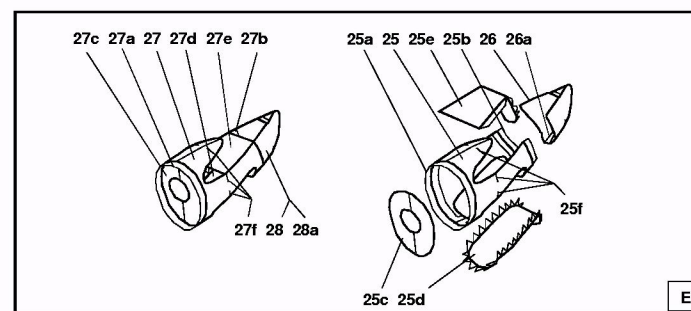
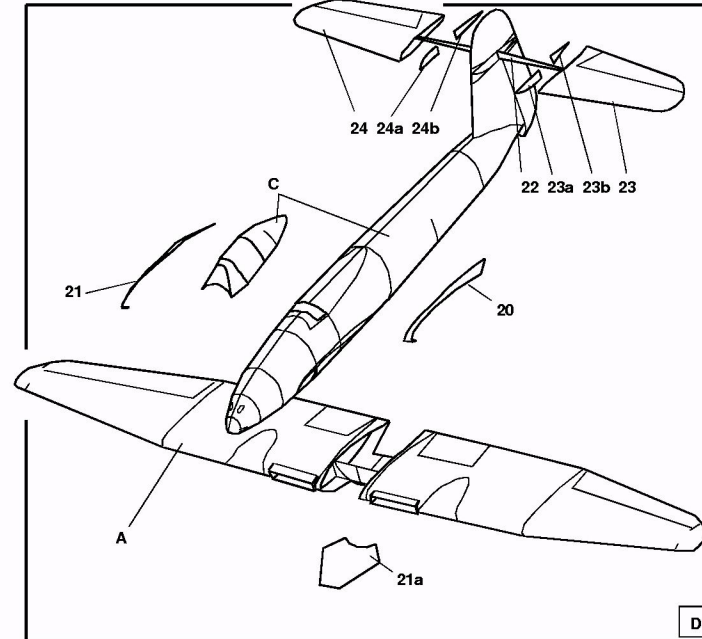

Westland Whirlwind Mk II

© 1997 E. Zarkov

ASSEMBLY INSTRUCTION

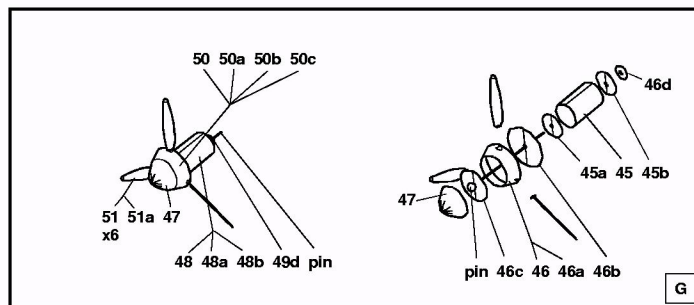
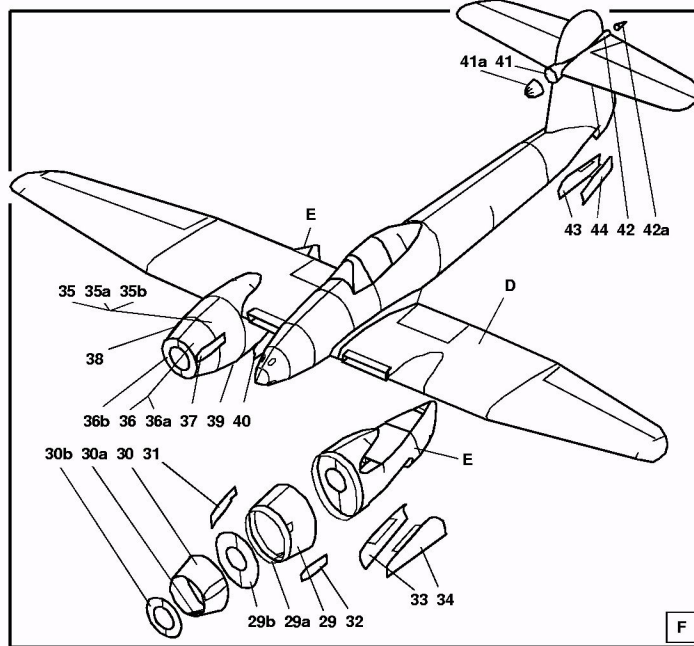

Westland Whirlwind Mk II

© 1997 E. Zarkov

ASSEMBLY INSTRUCTION

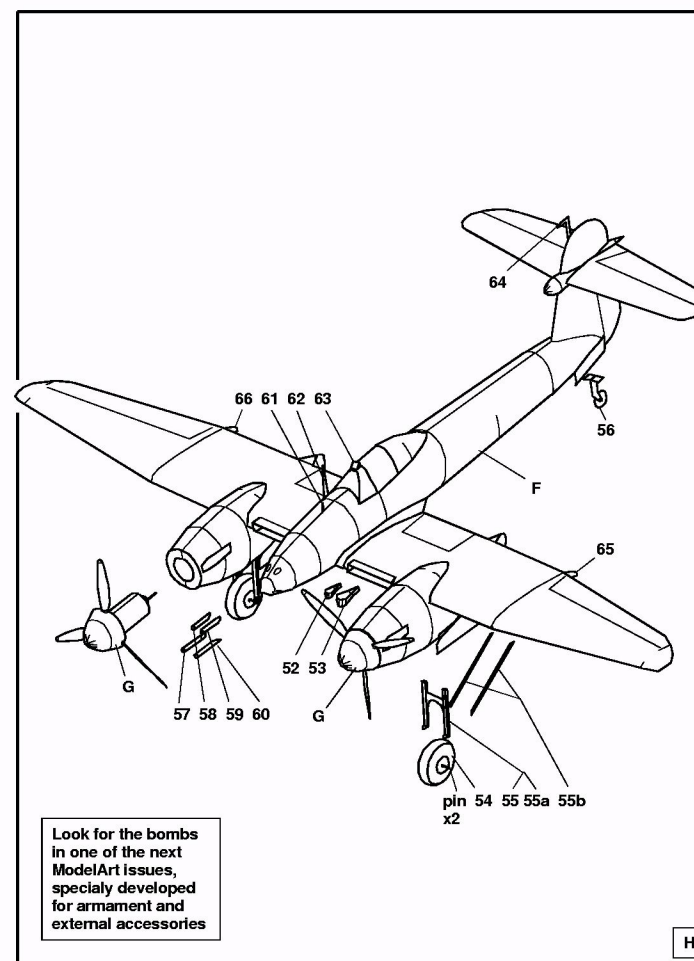

Westland Whirlwind Mk II

ASSEMBLY INSTRUCTION

WESTLAND WHIRLWIND Mk II

Study drawings of assembly steps carefully before starting the work on the model. Make sure you understand the purpose and the place of each part.

The assembly requires some basic tools, such as scissors, sharp modelling knife, blunt knife for scoring the fold lines, ruler and needle. Additional materials you need are 4 pins to make the airscrew's and wheel's shafts and one piece of cardboard approx. 0.3 mm thick for reinforcing elements and wheels. You'll need of course suitable cement too. For cement application you can use toothpicks or some similar tool (special fine cement applicator is most suitable if you have one).

First of all you must score with the blunt knife all fold lines shown on the cutouts with short marks near the parts. To avoid mistakes and lost parts cut necessary details shortly before their use.

Start with the wing frame. Cut the parts 1* - 3* and assemble them as shown on the instruction drawings.

Cut the two central halves of the wing 4* and 5*. If you want realistic cooling intakes cut their places in the central front wings' area. Carefully bend and form the wing halves. Glue them together using corresponding connecting stripes 4a, 4b, 4d, 5a and 5b. Glue the

WESTLAND WHIRLWIND Mk II 1

airframe first on the internal down side of the wing and after few tests without glue assemble the wing. Insert the radiators 4c and 5c in the prepared cooling holes in 4 and 5. Add the two wing consoles 6 and 7. Watch out for the wing profile and diheder and avoid warping.

Assemble the fuselage /parts 8* - 15*/. If you want retracted landing gear, omit the two cuts in the rear end of 14 and part 14c. Add the vertical stabiliser 16 and prepare the canopy - parts 17* - 19. Glue the fuselage to the wing. Cut the aerodynamic wing-fuselage joints 20, 21, and 21a. For cleaner job it's recommended to apply cement not on these parts, but on their attachment points on the wing and fuselage. Glue the prepared canopy and horizontal stabilisers 23* and 24*.

Prepare the engine gondolas 25* - 27* as shown in the drawings. If you want retracted landing gear omit parts 25d and 27d and don't cut the wheel covers on 25 and 27. Note that for obtaining double concave shapes of the gondolas, you must carefully make the necessary small cuts on them.

Glue the engine gondolas on their places on the wing and add to them the engine cowlings 29*, 30* and 35*, 36*. Glue the exhaust-pipes 31, 32 and 37, 38 on their places on 30 and 36. If you choose landing gear in down position, glue the wheels' covers 33, 34, 39, 40, 43 and 44 on their places. Cut and assemble the

WESTLAND WHIRLWIND Mk II 2

aerodynamic joint between the horizontal and the vertical stabiliser - parts 41, 41a, 42 and 42a.

Make the airscrew's shafts cementing the pin's heads to the forming parts 48 c and 50c, as shown on the drawing. The pins must be coaxial with the cylinder's 45 and 48 centrelines. Put the pins into the cylinders, then cement the limiting discs 46d and 49d on pins' rear ends. The airscrews' shafts must be able to turn freely in the cylinders' bodies, but with minimal clearance. Then make and cement the spinners using parts 46*, 50* and 47. Prepare and cement the airscrews' blades 51, 51a on the spinners

Assemble the landing gear (parts 56-56) as shown on the instruction drawings. Make the wheels from cardboard (parts 54) and paint their edges with suitable paint - water based or acrylic; the easiest way is to use black marker. Insert the pins in the centre of the wheels and then cut the pin's edges to form the wheel shafts. Glue the shafts on 55, covering them with their small bottom stripes, then glue parts 55 in the engine gondolas, fixing them with 55b in the correct position.

Add the details - armament 57-60, Pitot tube 64, antenna mast 61, rear view mirror 63, parts 65, 66, and cowlings 52 and 53

Carefully insert and cement the airscrew bodies of the propellers' assemblies into the engines. Be careful - use

WESTLAND WHIRLWIND Mk II 3

cement sparingly to prevent cementing of the rotating shafts.

If you prefer flying model, make your aircraft with retracted main landing gear, without propellers 51 and 51a, and without machine guns 57-60. Put some weight in the nose and symmetrically in the spinners to balance the flying model. The model's centre of gravity must be on approx. 25% from the wing chord.

Now your model is ready. Enjoy your Whirlwind!



WESTLAND WHIRLWIND Mk II 4