

North American **P-51 D** **MUSTANG**

1/32 SCALE PRECISE CARD MODEL

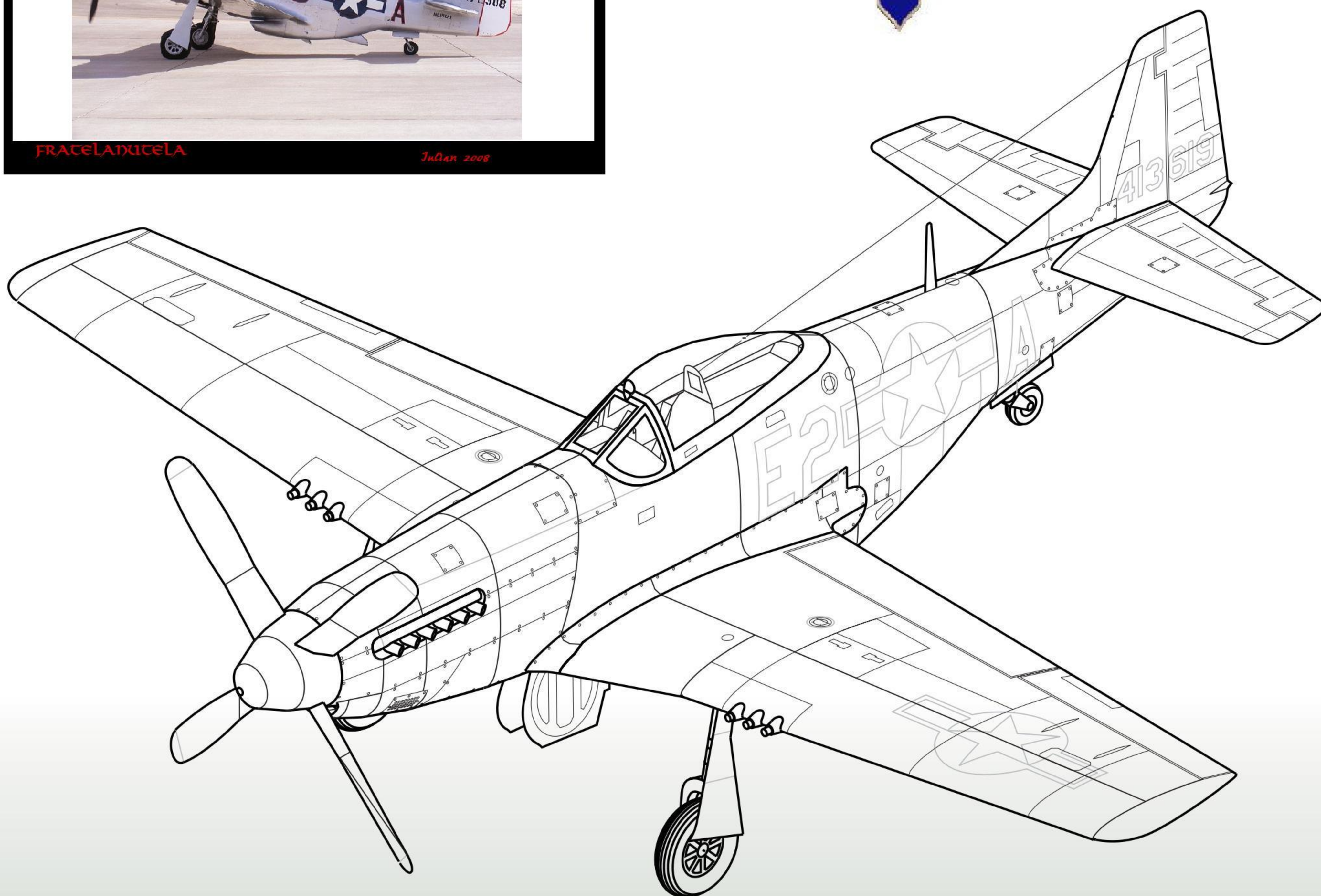

1/32 SCALE P-51 D MUSTANG

ASSEMBLY INSTRUCTION

The proposed P-51 D Mustang model is comparatively easy to be build but its high level of similarity to the real aircraft requires special attention and high precision during the assembly process.

Study carefully the illustrative drawings, cutouts and present instruction before starting the work on the model. Try to imagine the separate assembly phases and the purpose of each detail.

After the acquaintance with the model, you may start the assemblage. Follow the sequence given in the instruction. Cut the necessary details shortly before using them in order to avoid possible mistakes. Score all fold lines before cutting the details. The places of scoring are marked with small thin lines on the continuation of fold lines outside the parts. The small red line markings show where to make cuts on the wing-fuselage joint cowlings.

Do not be in a hurry with gluing - carefully check and shape the details until obtaining the exact and correct fit. Before starting the work get hold of the necessary tools: scissors, sharp modeling knife, blunt knife for scoring the fold lines, prickler, ruler, nippers and grinding paper. Additional materials necessary for the assemblage are: sheet of cardboard with thickness approximately 0.5 mm, a piece of wire with diameter 0.5 - 0.8 mm. Supply with proper glue. BISON Clear Adhesive, UHU or similar are recommended as the most appropriate ones. Water based glue is not recommended. Preparation for assembling includes gluing pages that contain formers and strengthening elements on a 0.5 mm cardboard.

Start with the cockpit interior 1 as it is shown on a view A of the instruction drawings. Form the fuselage segment 2, glue on it connecting stripes 2a – 2e and close it. Insert in it formers 2f and 2i, then insert from the rear the cockpit interior part 1 and complete the segment by fixing on its place the former 2f.

Continue with the fuselage segment 3. Form it, glue the connecting stripes 3a- 3d and close it. Glue the rear part of the cockpit 3e and the former 3f. Then glue it to the segment 1, strictly keeping lines of symmetry.

Assembly the fuselage nose by adding segments 10-13 and the nose air intake 14, 15 as it is shown on view B. Complete the fuselage by adding segment 17, segment 19 with preliminary inserted rear wheel housing 18 and the vertical stabilizer 20-20c. You can use the bottom centerline pattern to obtain correct shape of the fuselage belly.

Glue inside the cockpit ruder pedals 4, instruments panel 5-5d, control rod 6, throttles control 7, pilots sit 8-8b, belts 8c and the gun sight 9-9t.

Assembly the cockpit glassing 21, by forming it and gluing the transparent parts 21t. Be careful and avoid mess. Note that despite the weathering of the aircraft during its field exploitation, the part that is always kept crystal clear is the cockpit glassing.

If you've chosen junior option, you can omit interior and use the parts 8, 8a for the cockpit glassing.

You can use the cockpit centerline pattern during assemblage and gluing the cockpit to the fuselage. If you like to have antenna wire on your model, you should fix its end to the back of the pilot's seat

and to insert the other end in the hole of the cockpit before glue it to the fuselage, as it's shown on view C.

Continue with the wing. Assembly the wing reinforcing structure /parts 23-23h/, wheels housings 22 and cover them with the wing skin parts 24-27 and wingtips 28, 29. Keep the dihedral angle and do not avoid twisting of the wing.

Glue the wing to the fuselage and then place the wind-fuselage fillets 30, 31.

Insert the horizontal stabilizer reinforcement element 32 in the fuselage and glue the profiles 32a, 32b on their places. Then place the horizontal stabilizer parts 33, 34 and glue them to the fuselage.

Assembly and the cooling air intake 35-37 and glue it to the fuselage beneath the wing together with the cowling 55,55a.

Assembly the propeller 57-60 and its bearing 61 and propeller itself /55-60/, keeping the symmetry and the angle of attack of the blades 60. The propeller should rotate free in its bearing.

Continue the undercarriage as it is shown on the view H. Cut the wheel parts 42, 43, 45 from heavy card and glue them to each other, keeping their order. After drying the glue, round them by sand paper, paint their edges with black ink or flumaster and finally glue to them 42a, 42b, 43a, 43b and 45a. Assembly the undercarriage and glue it to the wings and fuselage, keeping the placement angles.

Complete the model by aging the the antenna mast 62 and the rear view mirror 56. Fix the rear end of the antenna wire to the vertical stabilizer.

Now your Mustang is ready.

Enjoy!

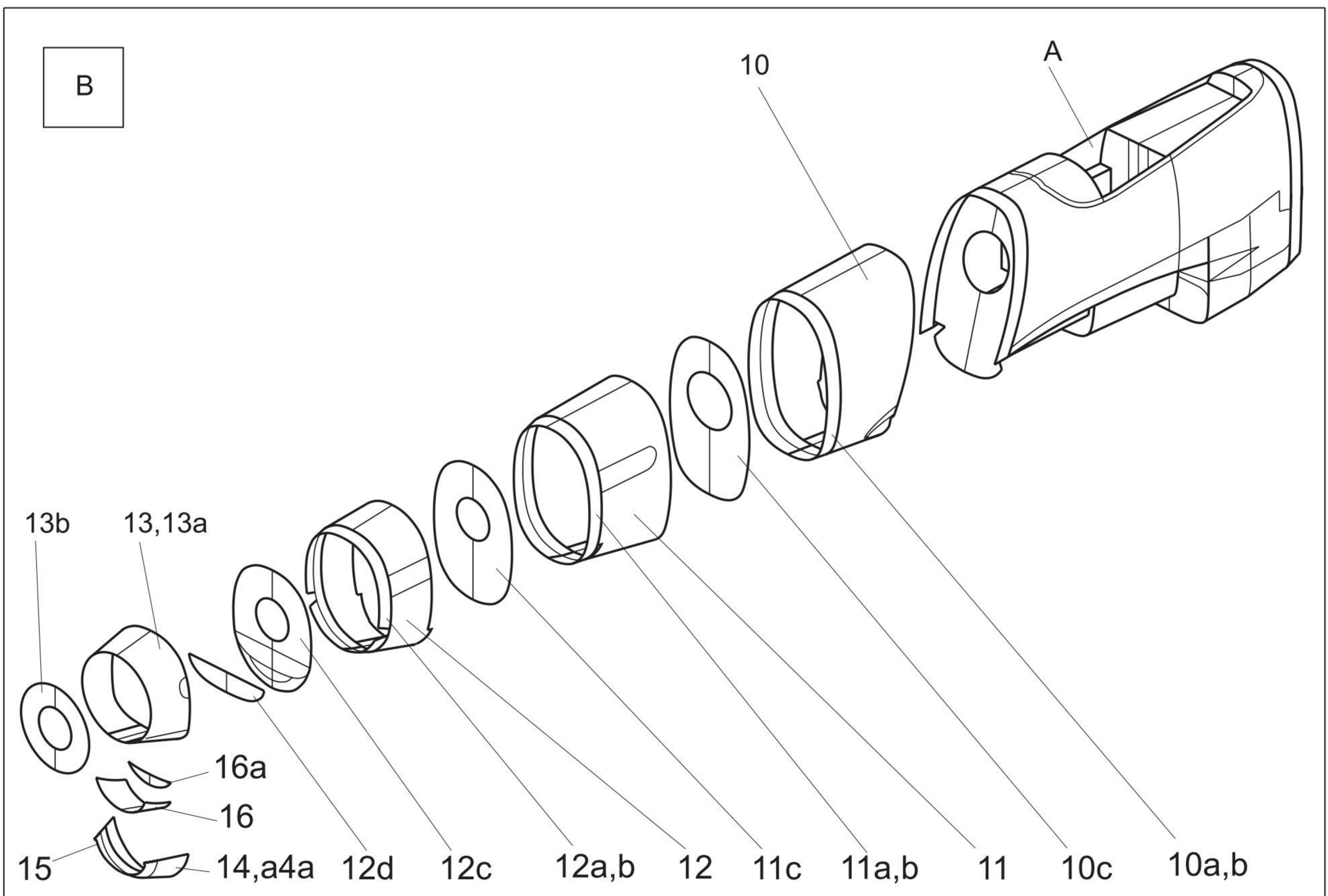
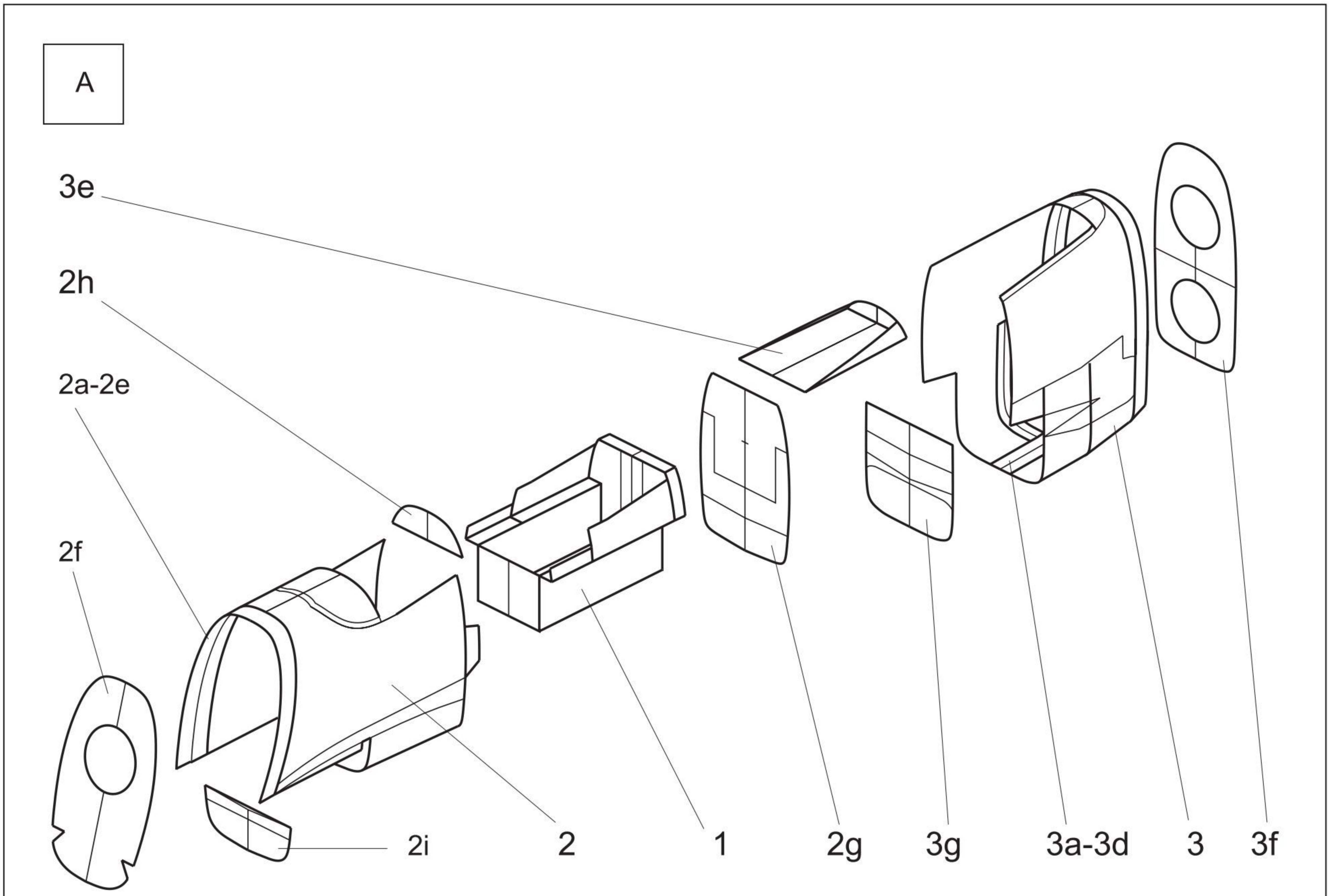

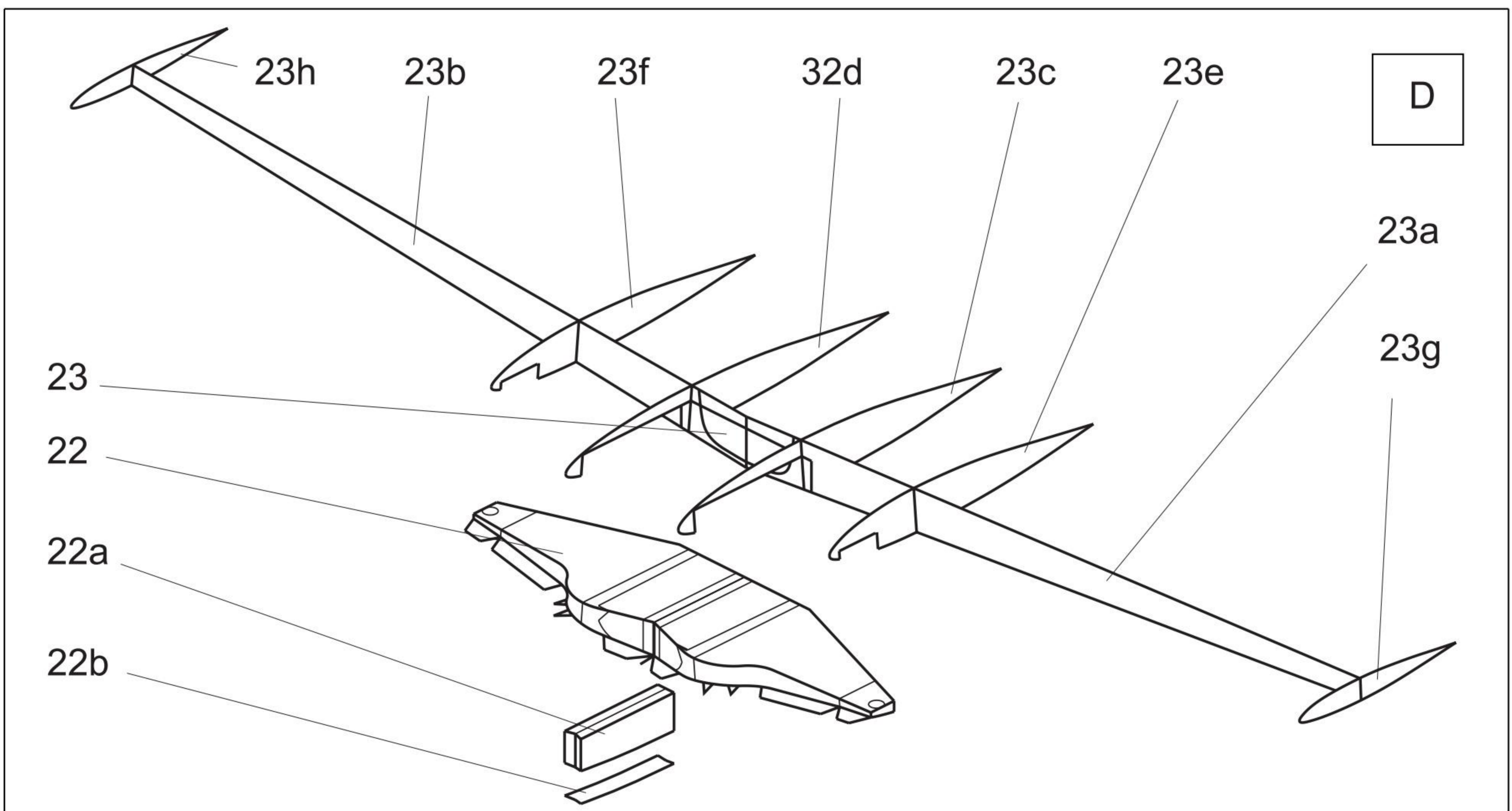
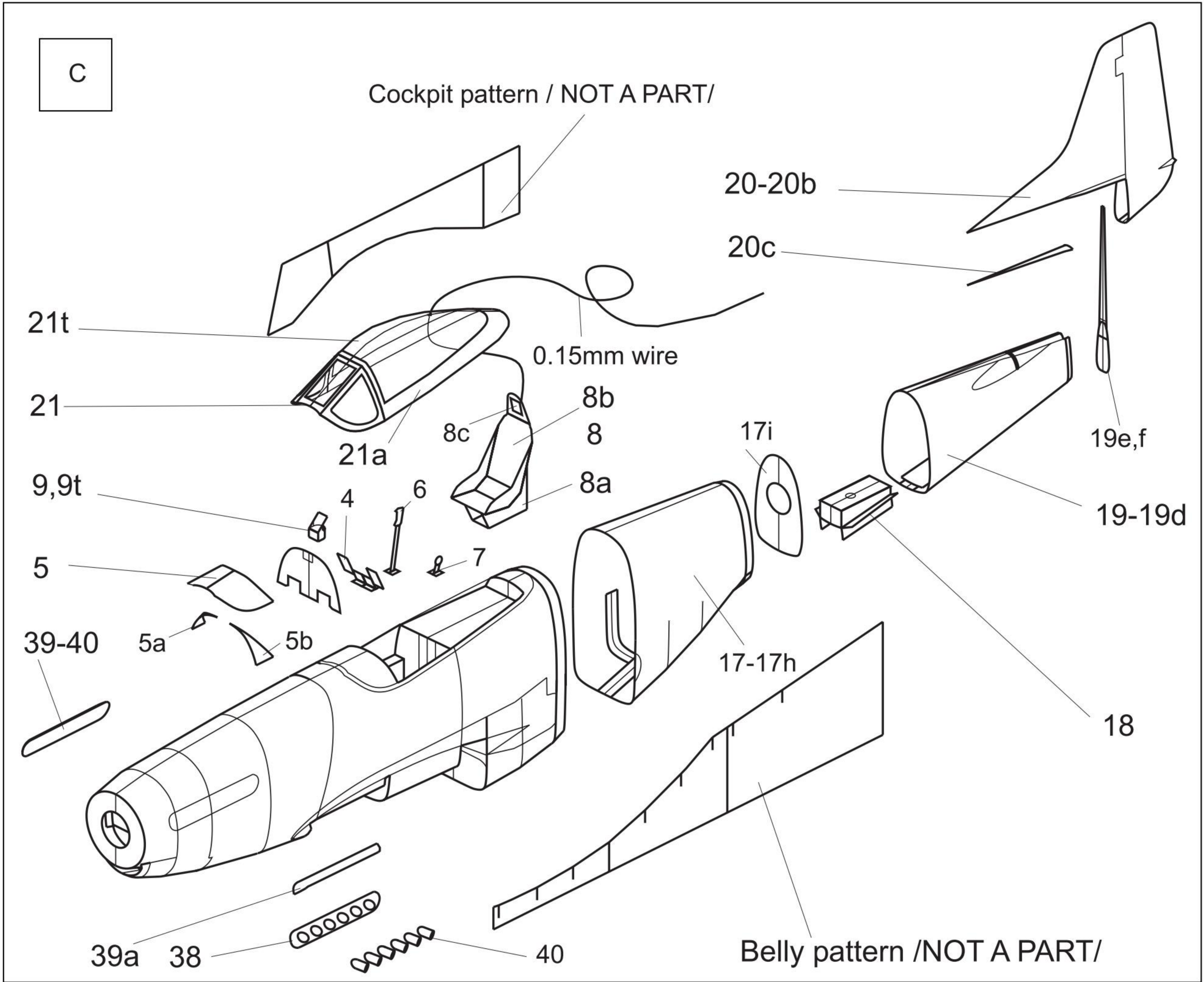

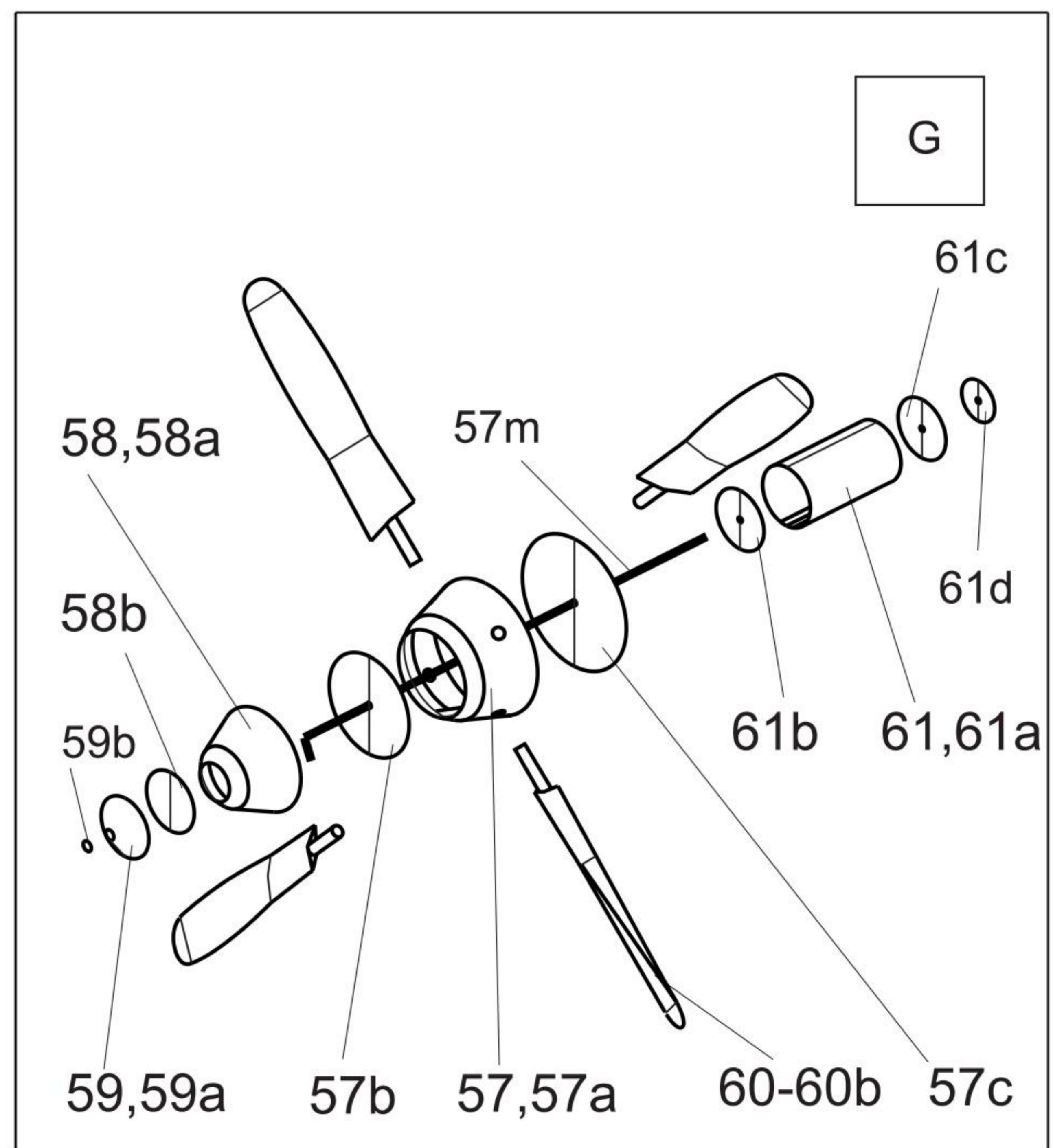
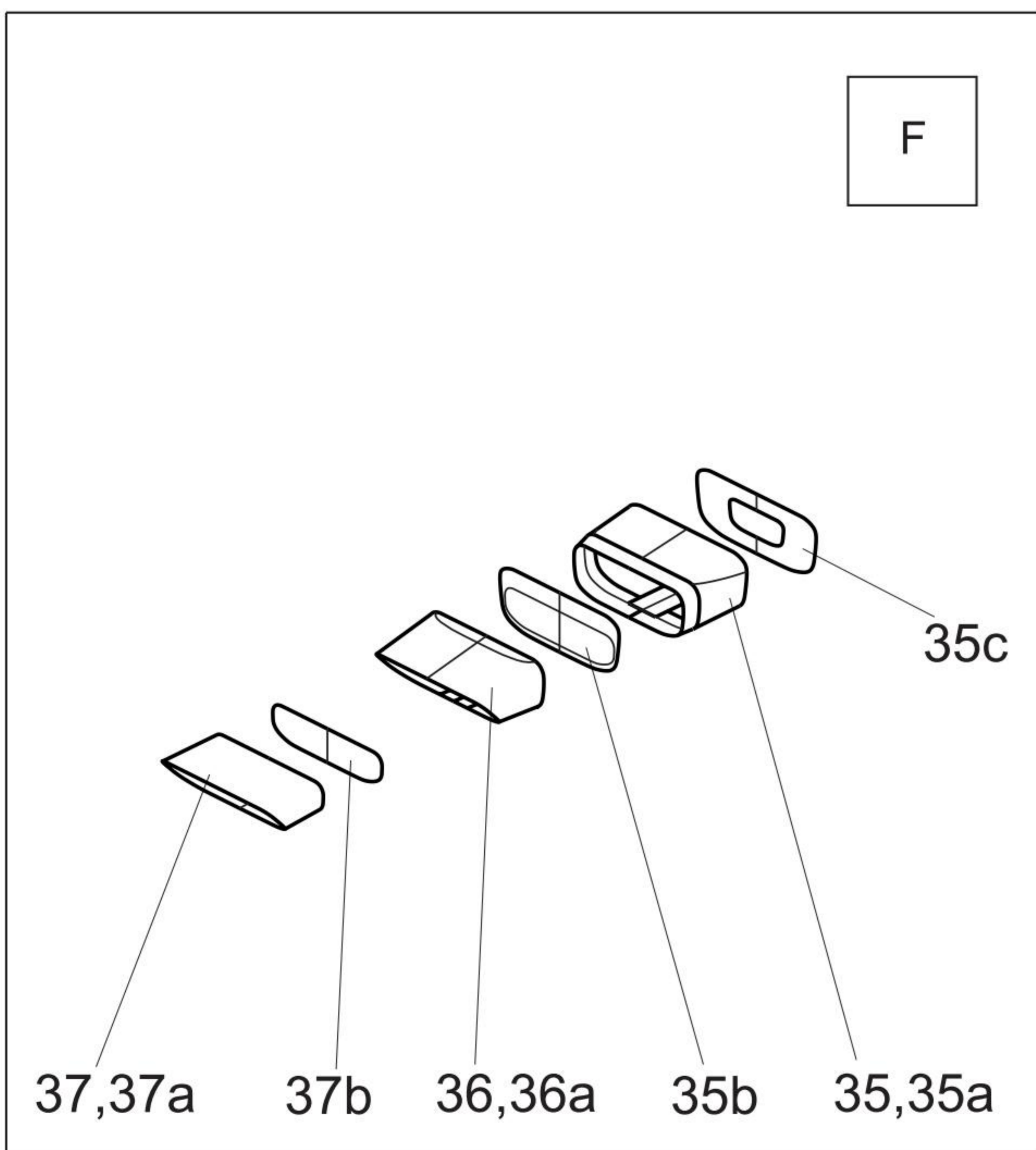
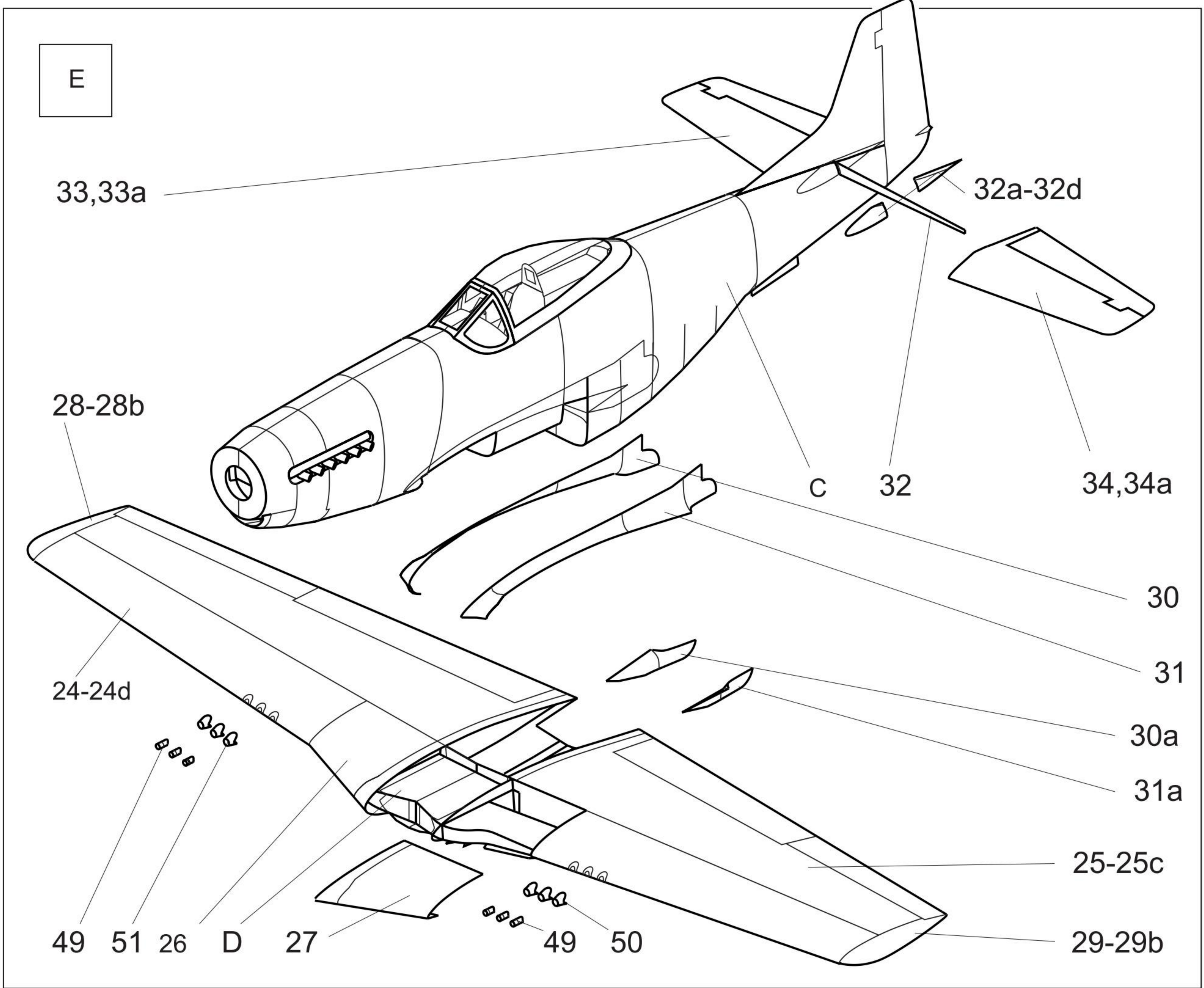

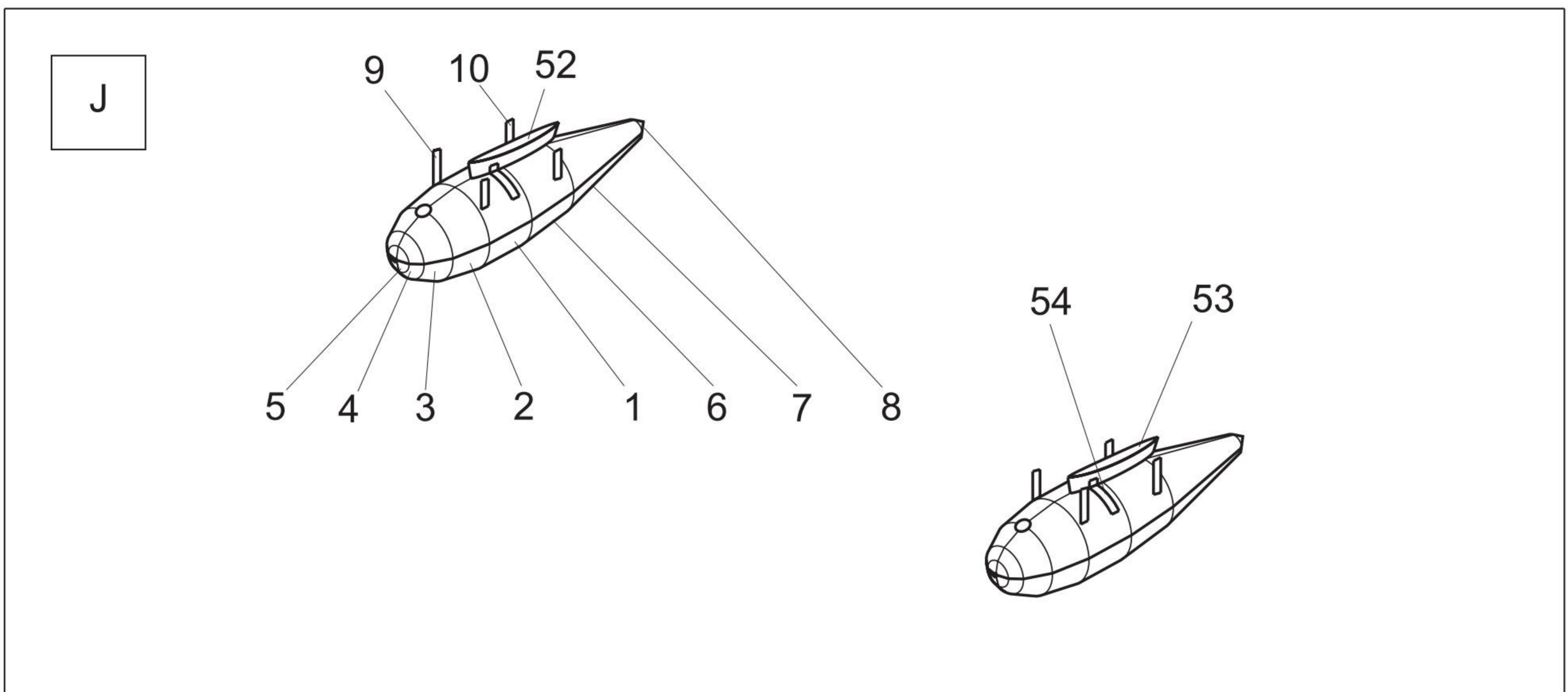
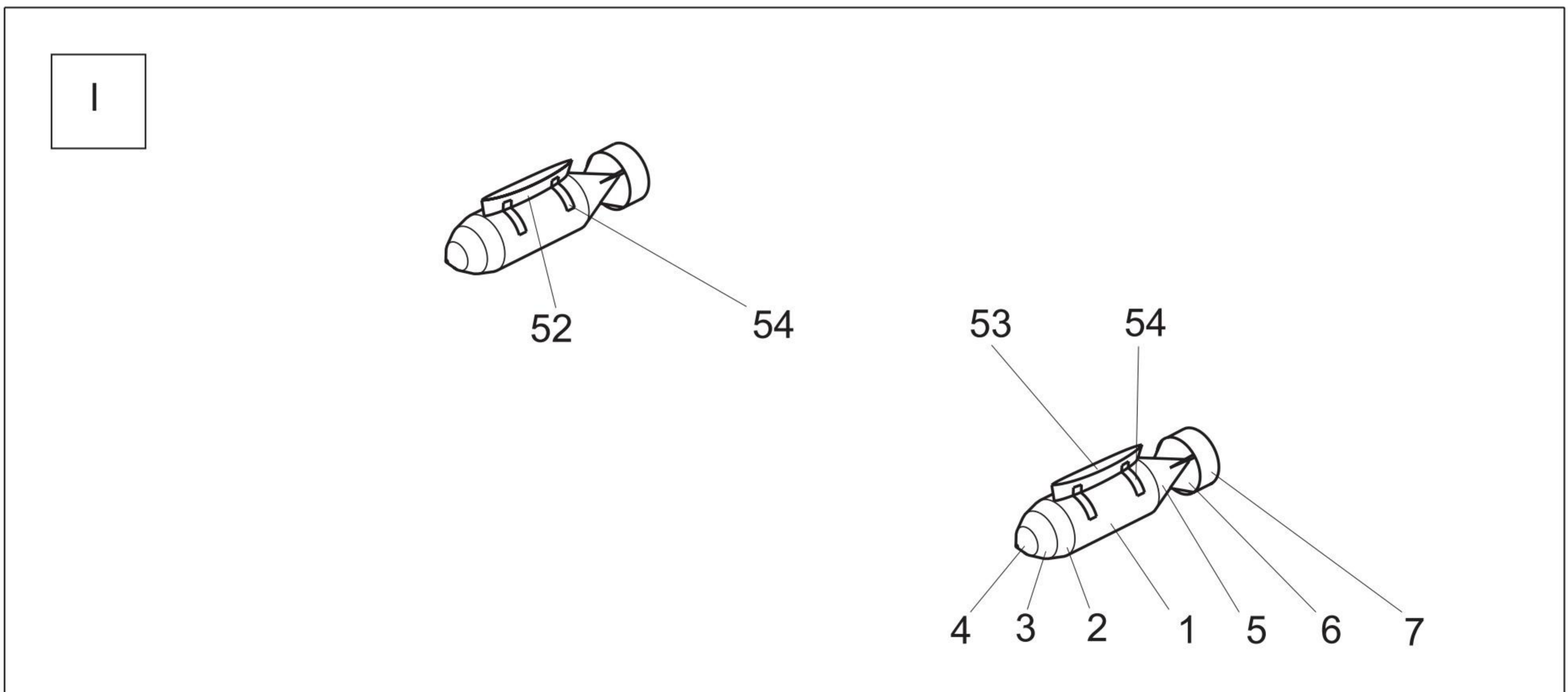
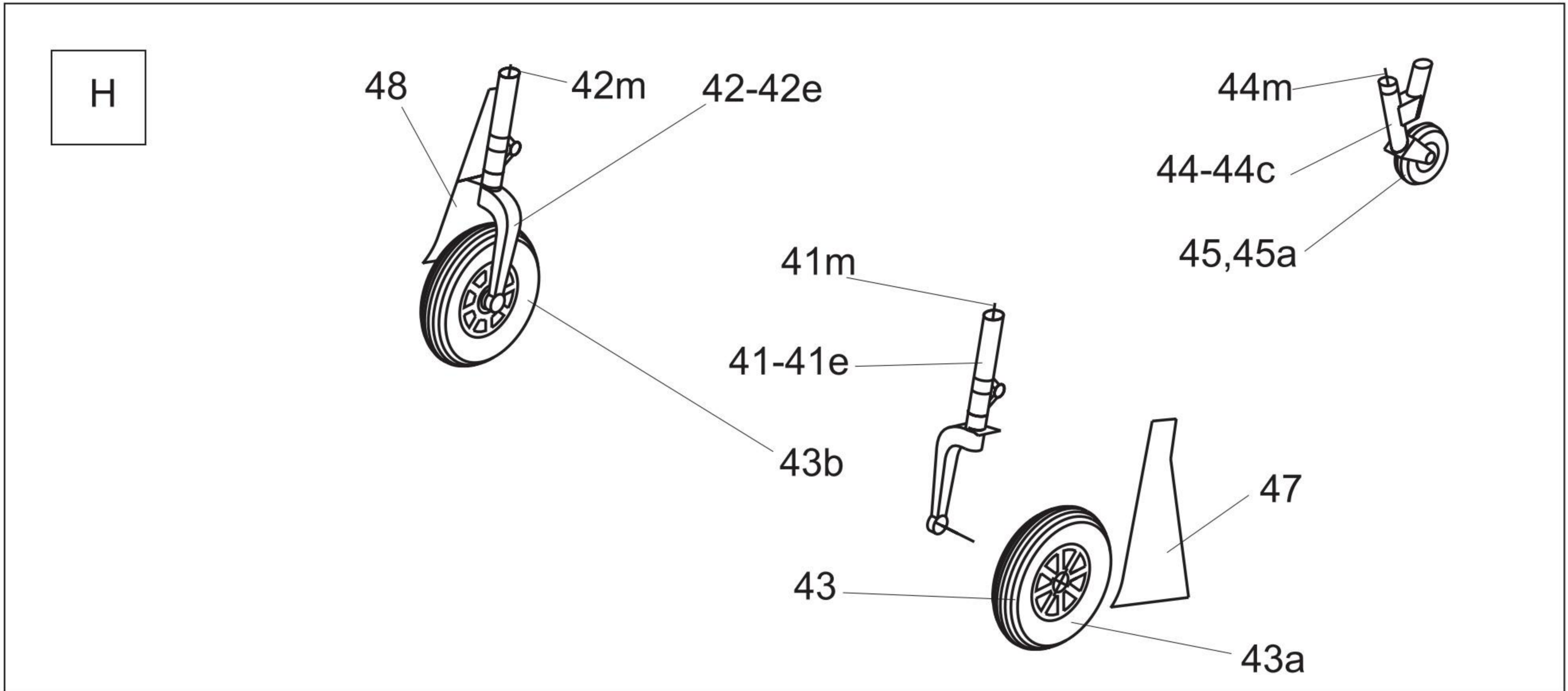

K

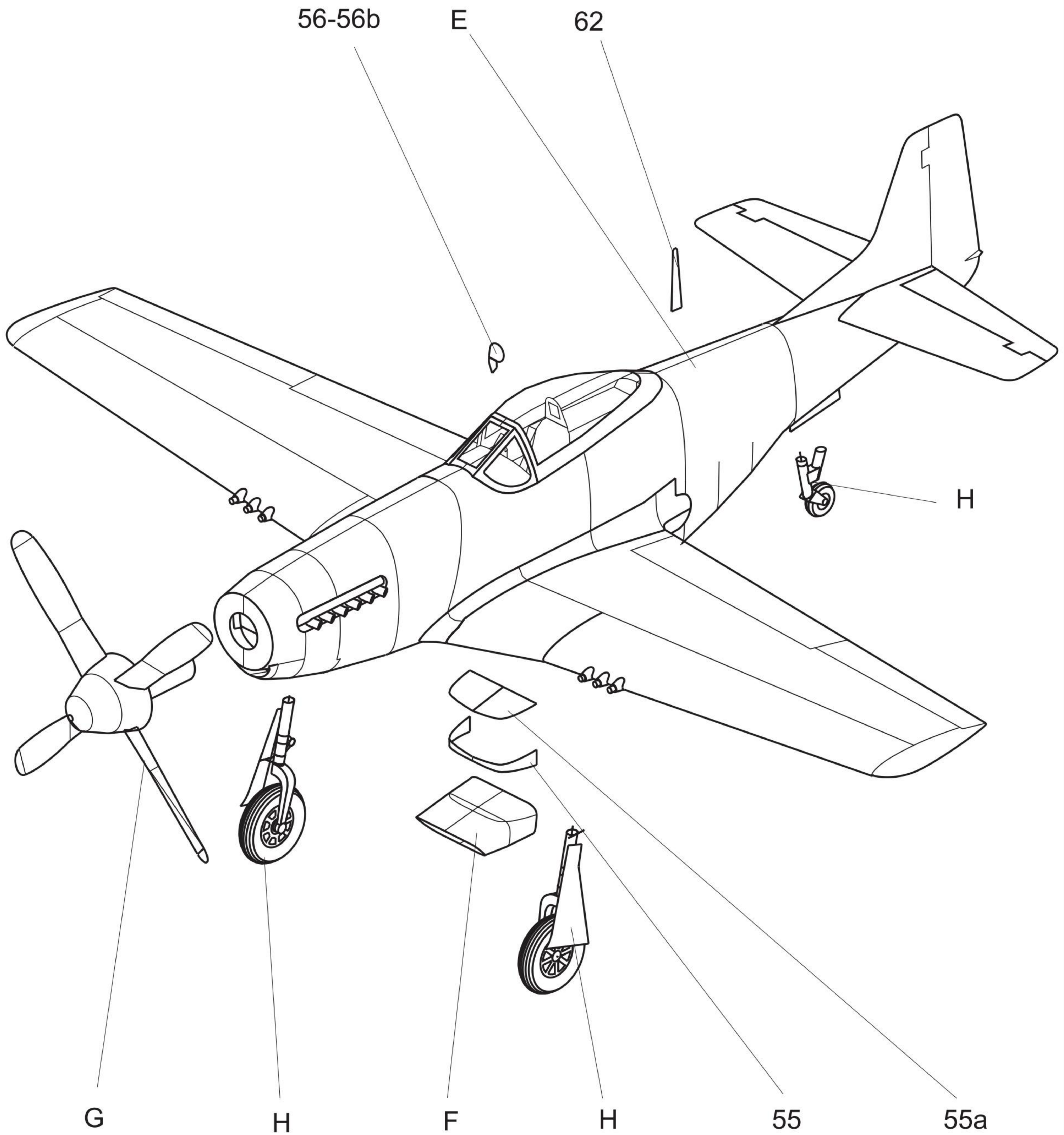

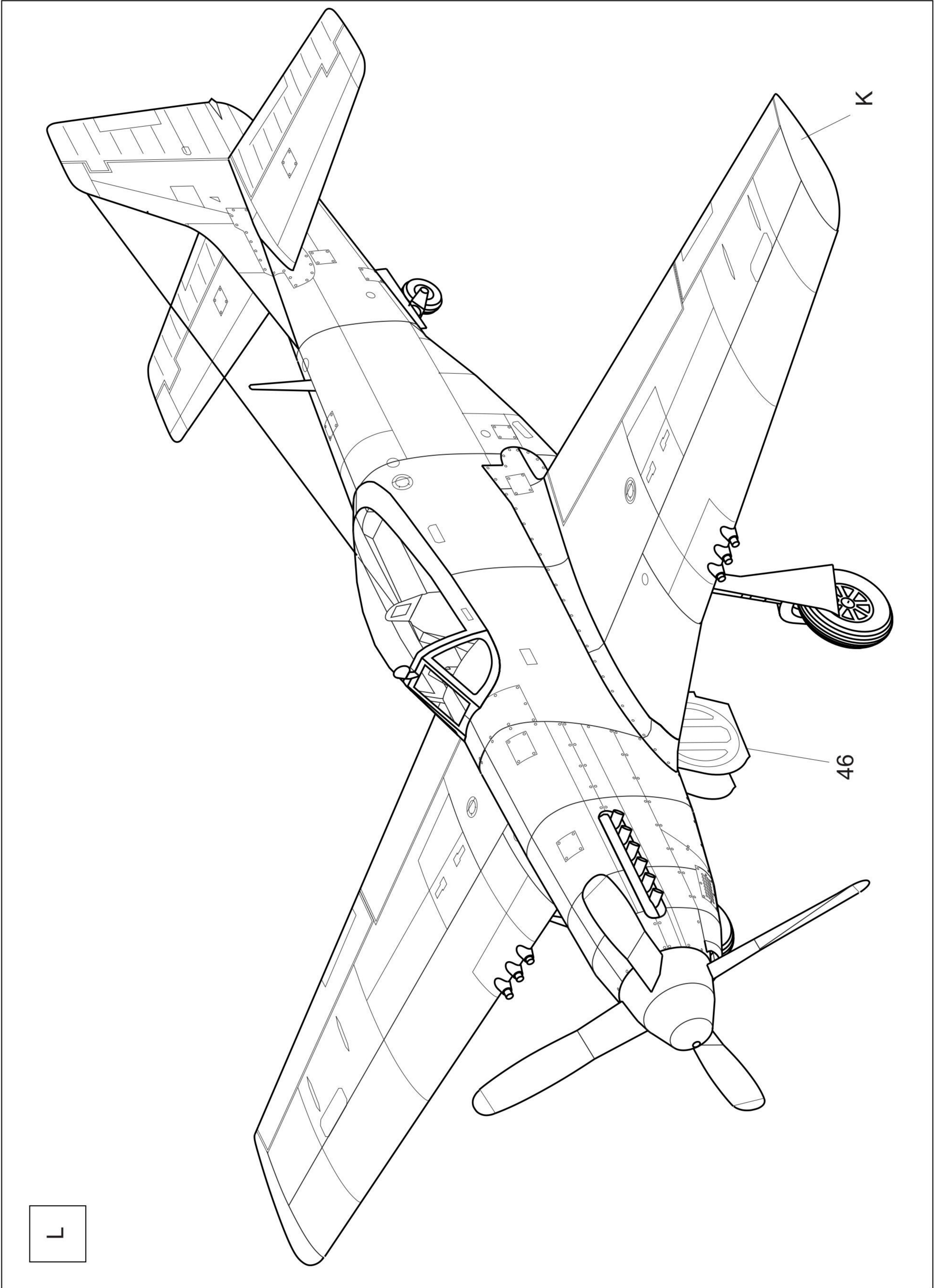

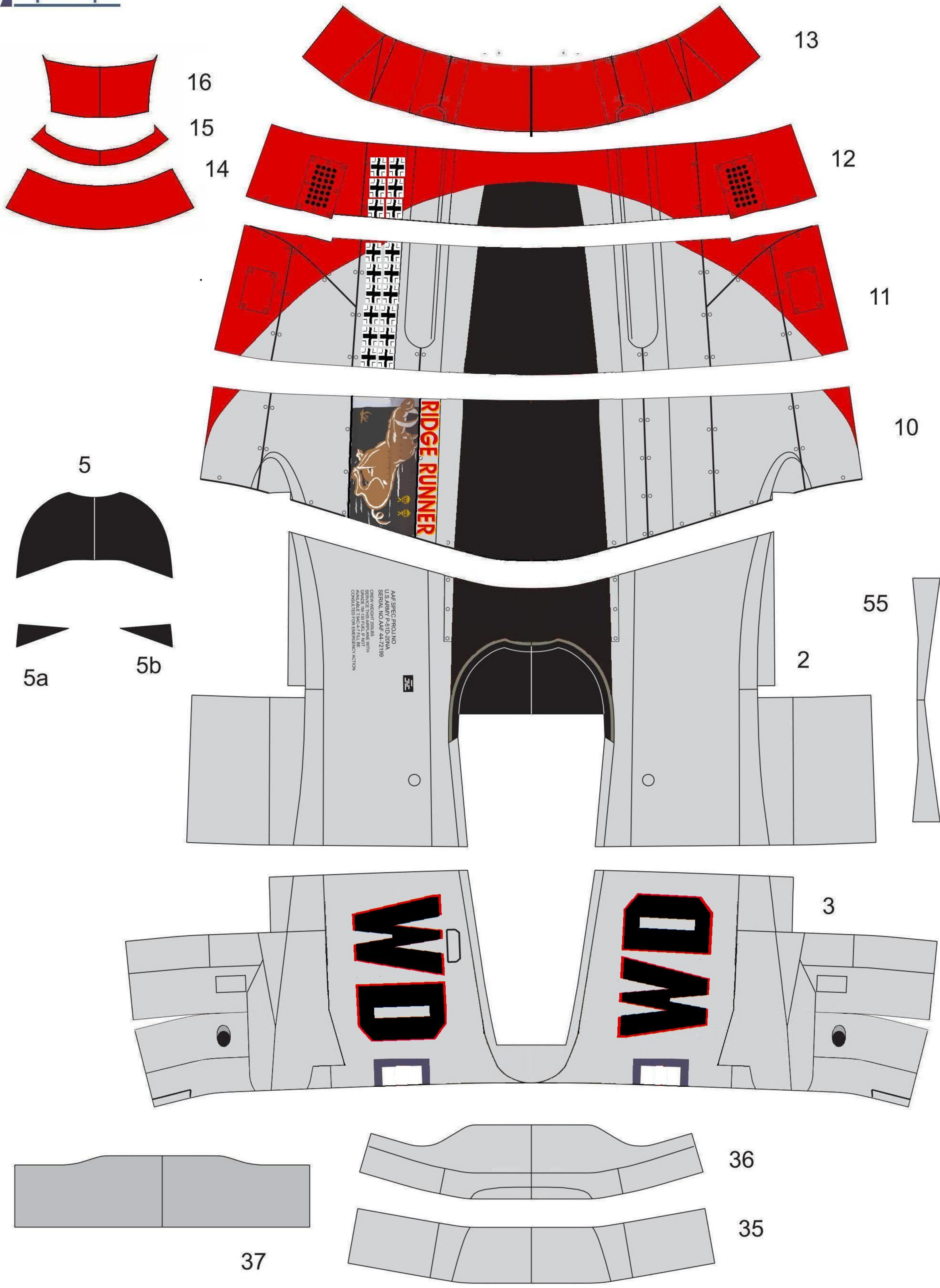

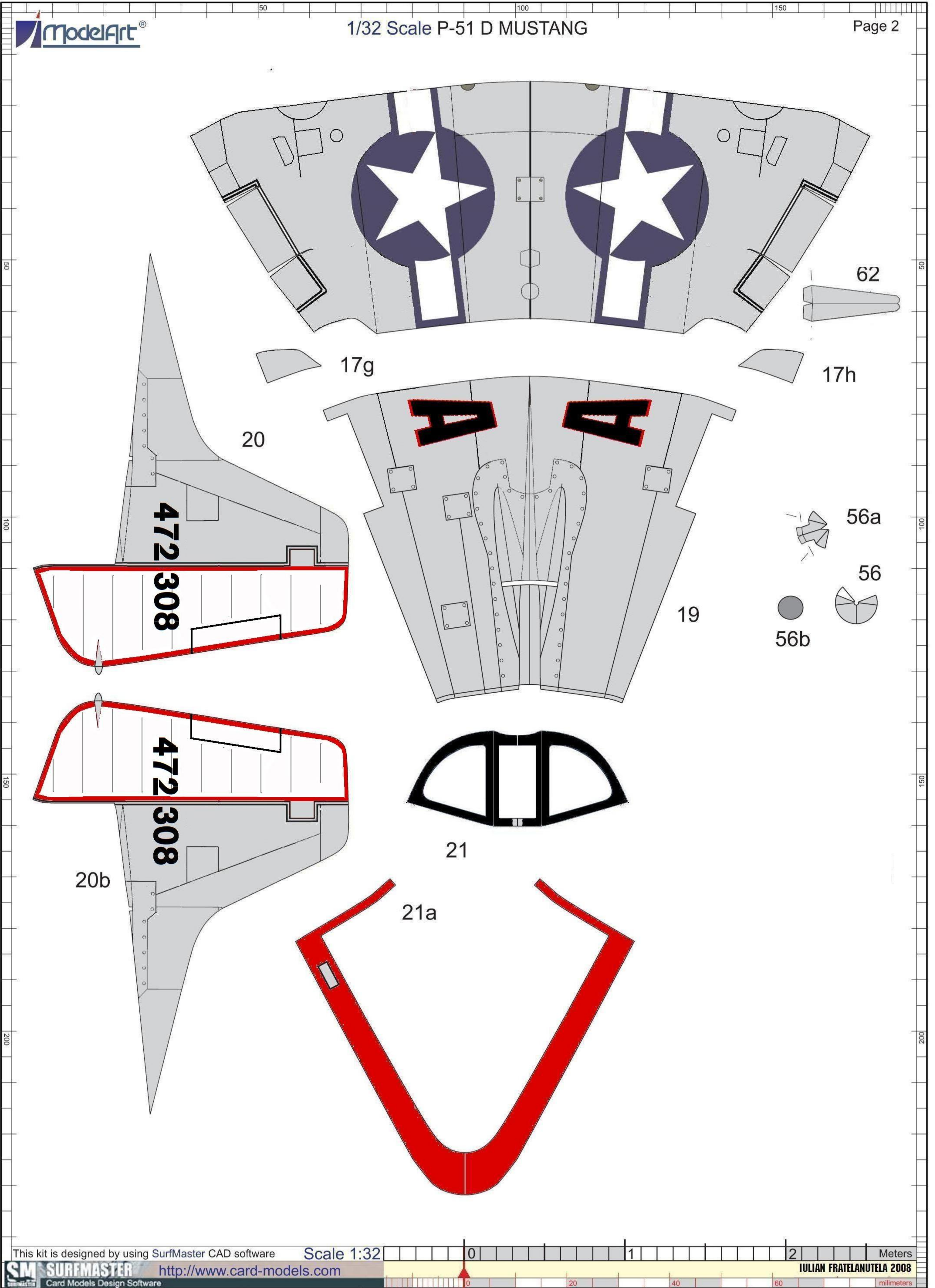

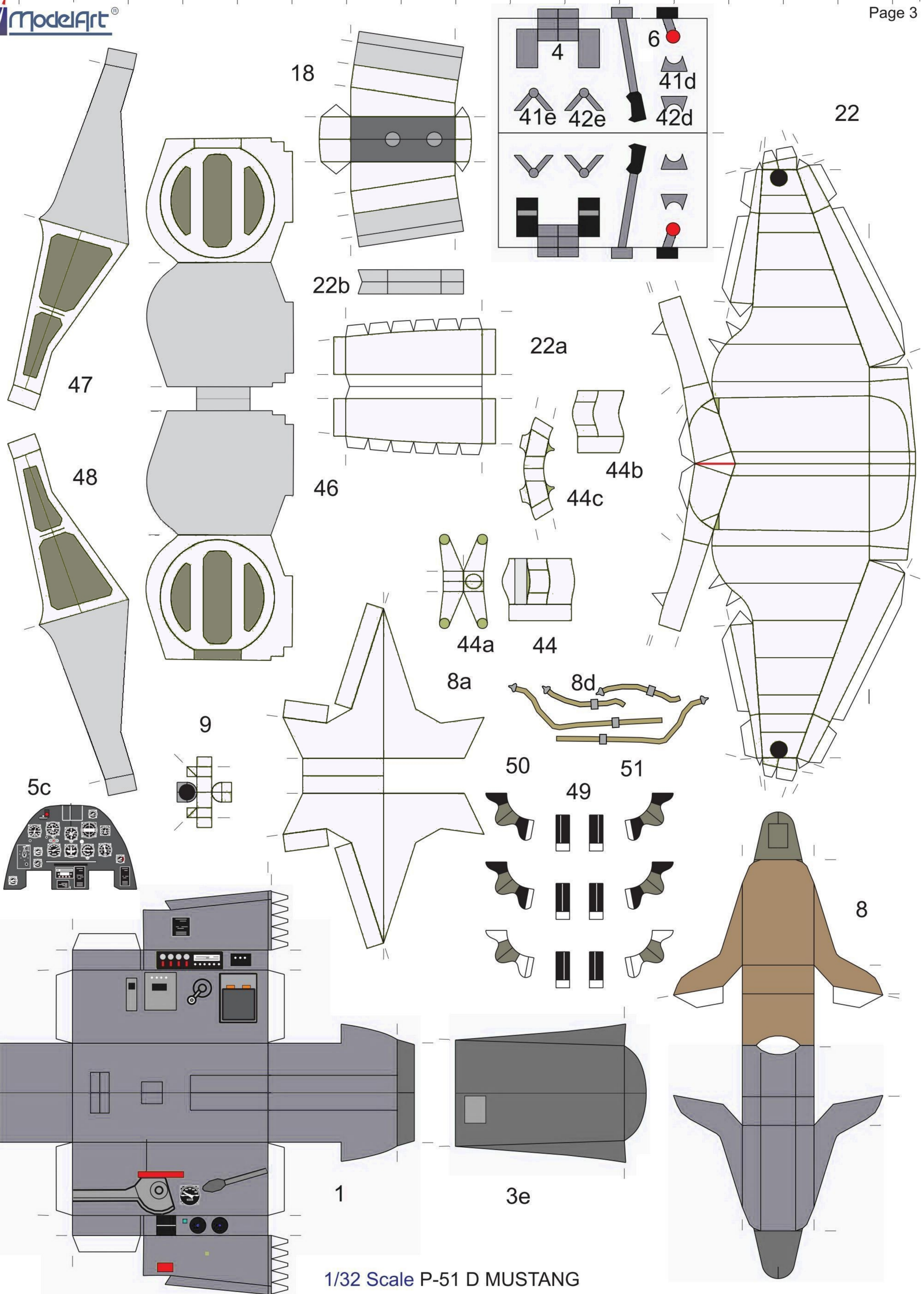

1/32 Scale P-51 D MUSTANG

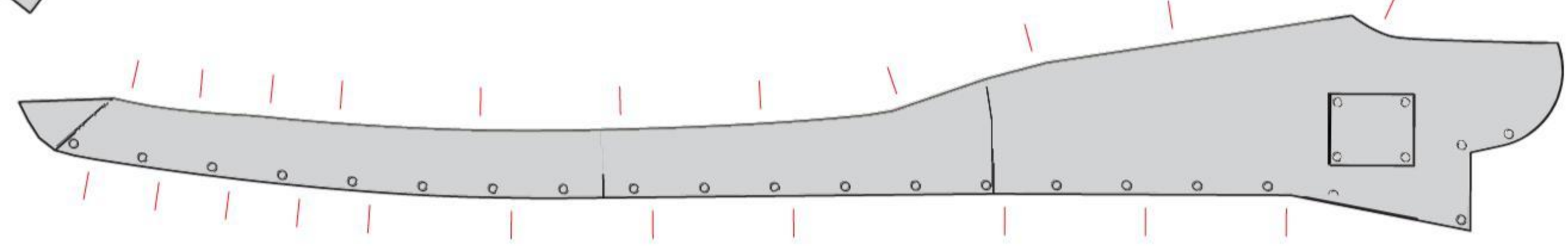
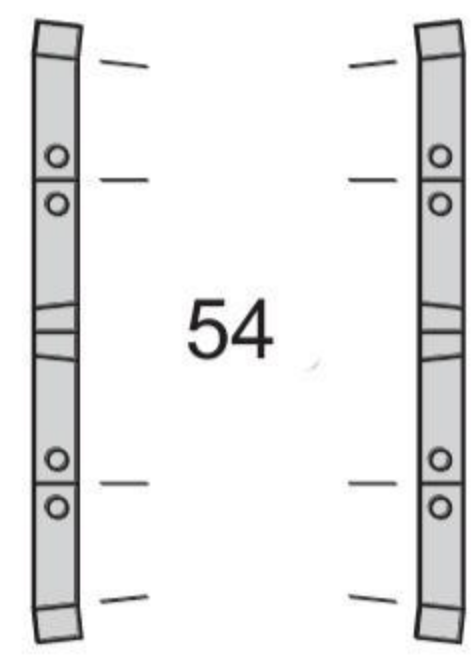
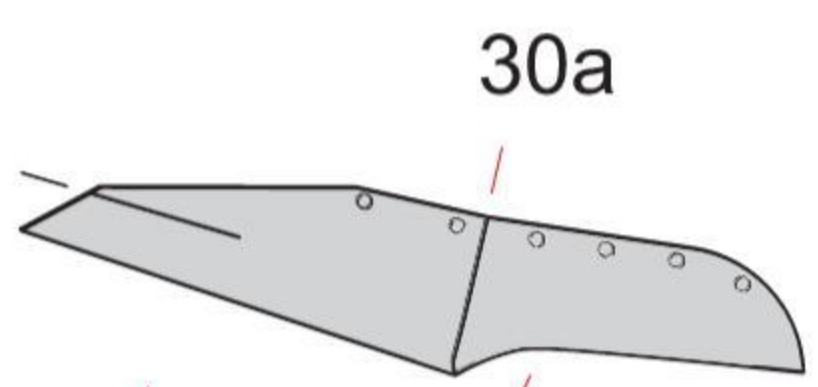
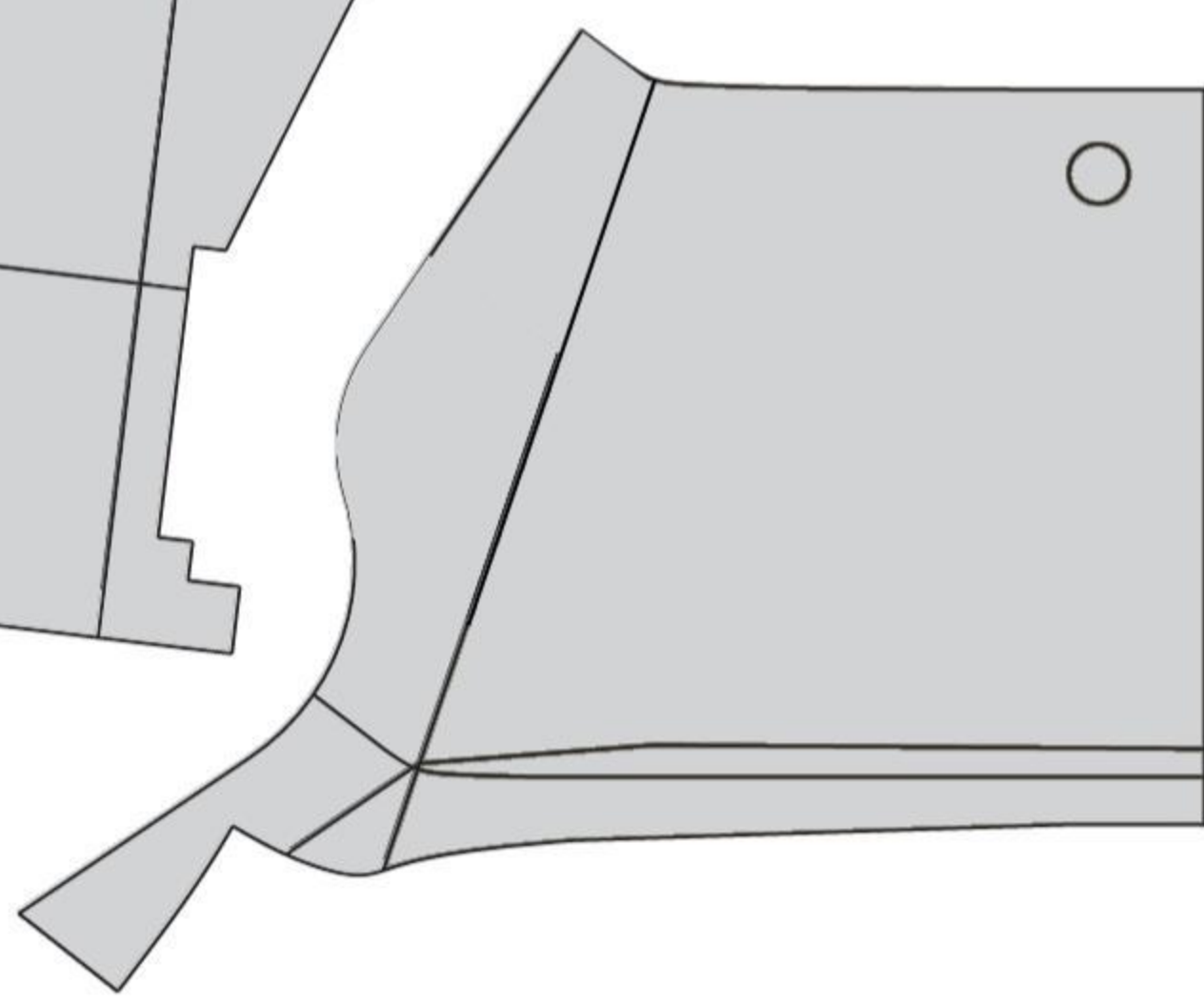
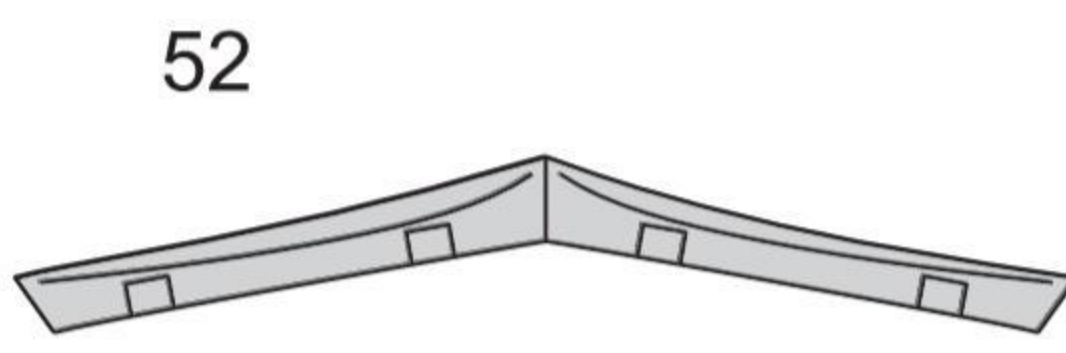
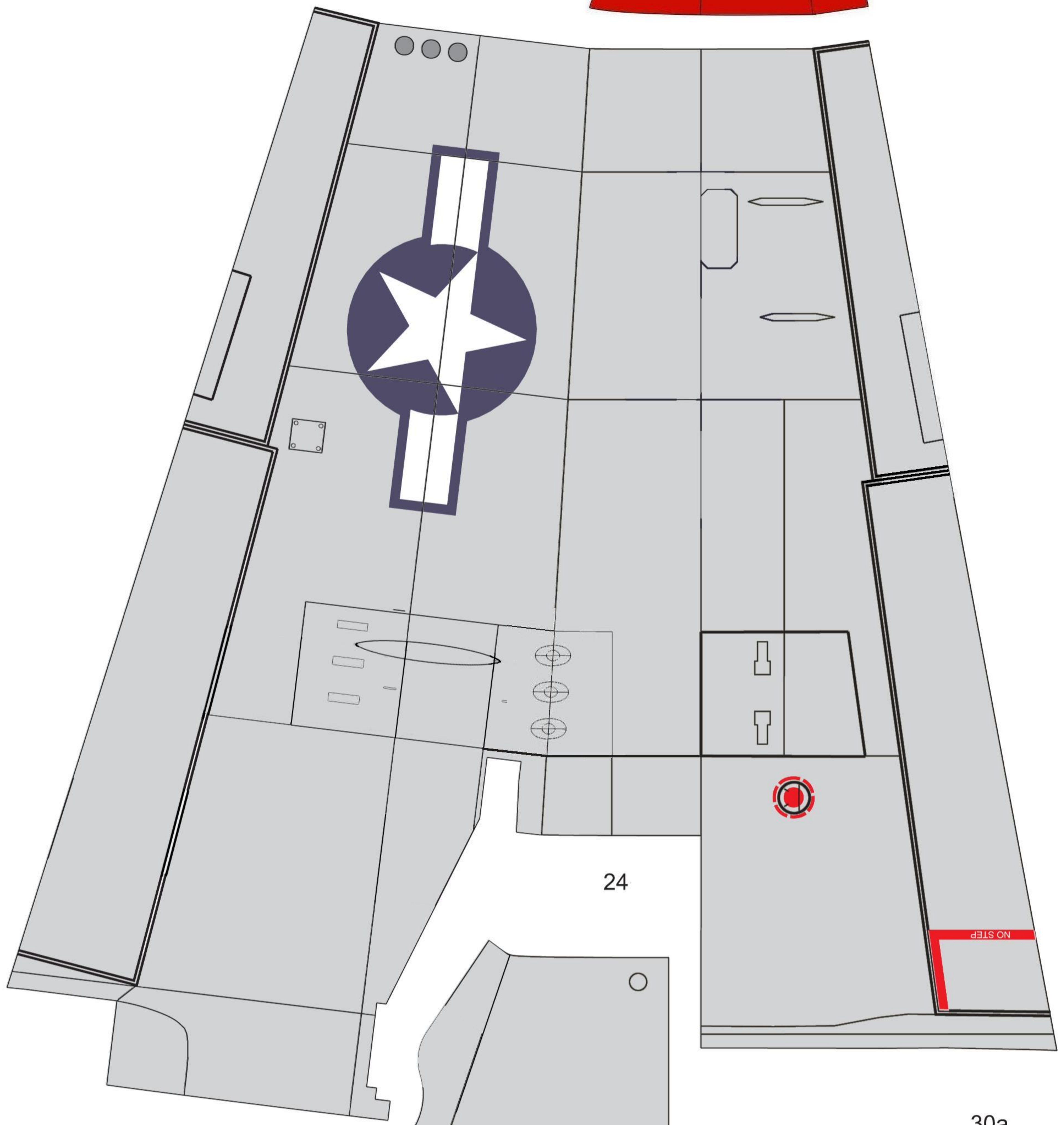
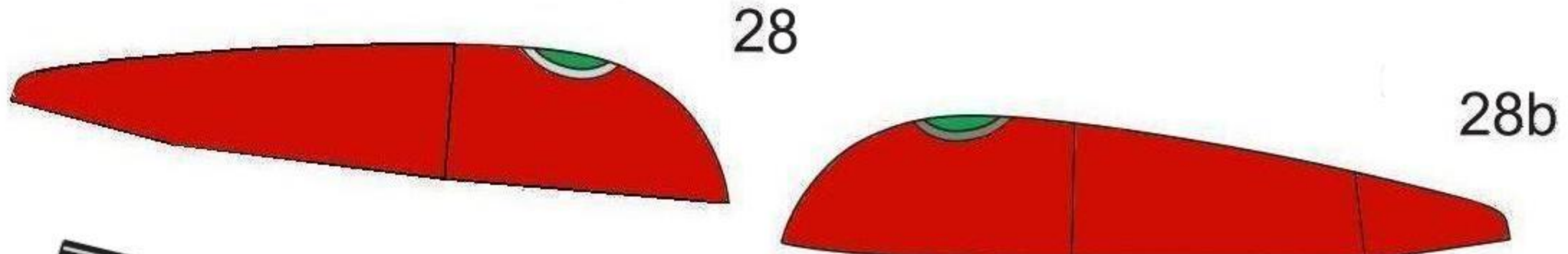

1/32 Scale P-51 D MUSTANG

29

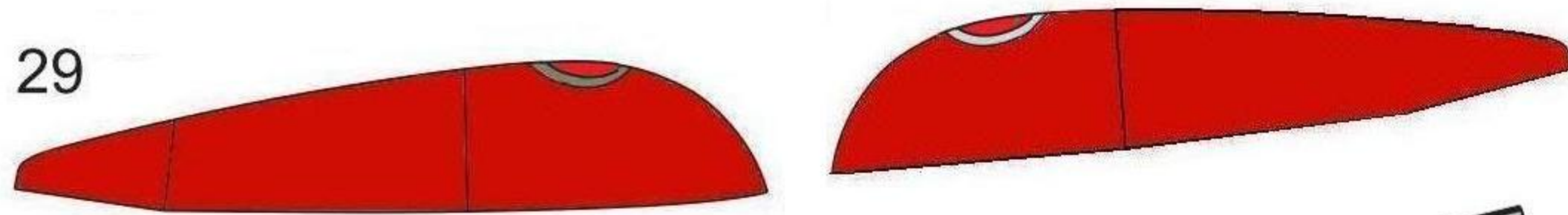

29b

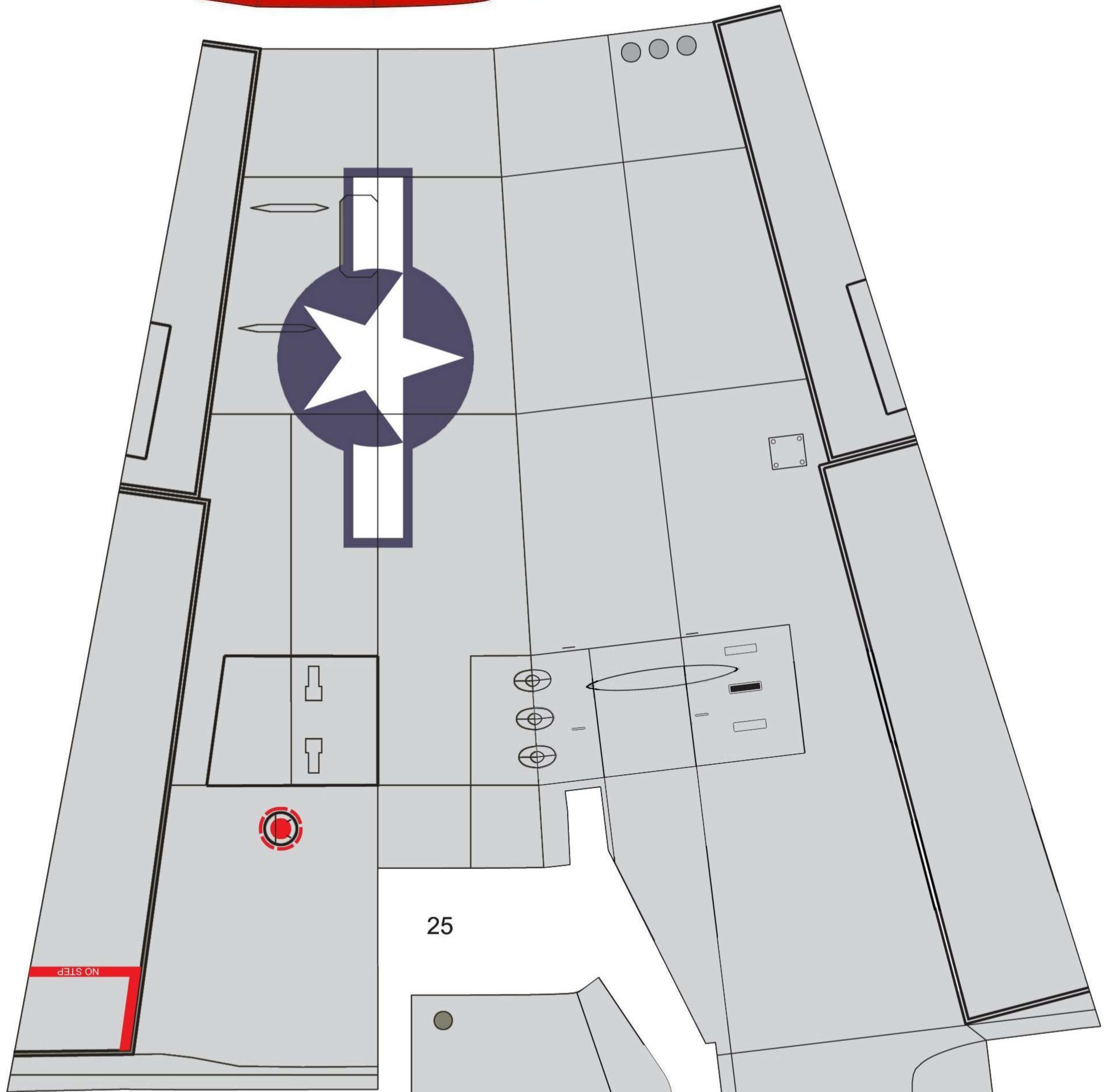

25

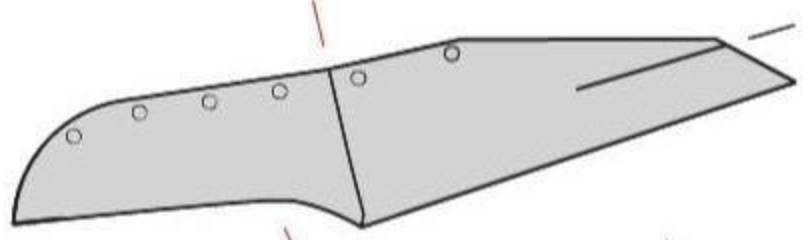

31a

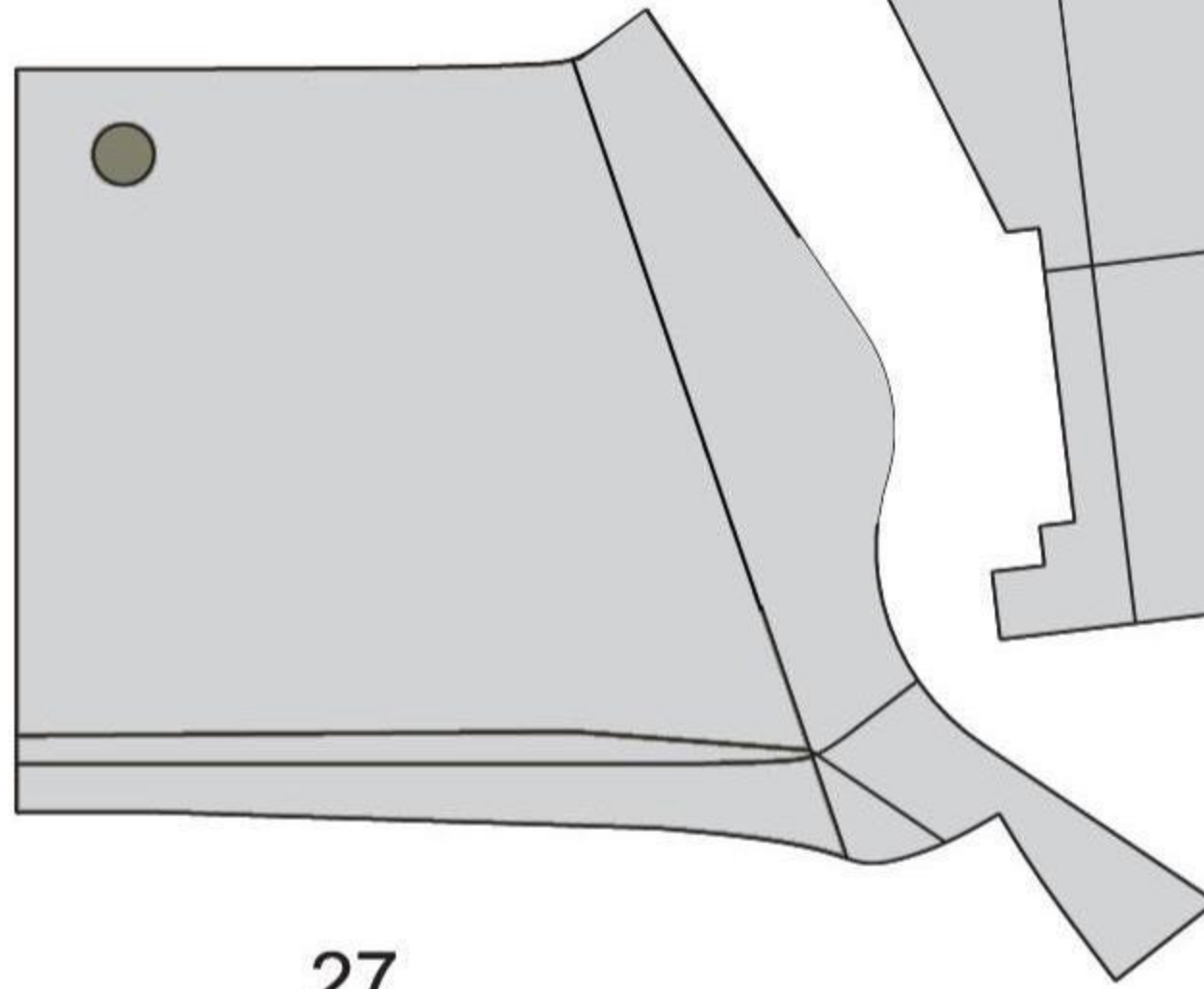

27

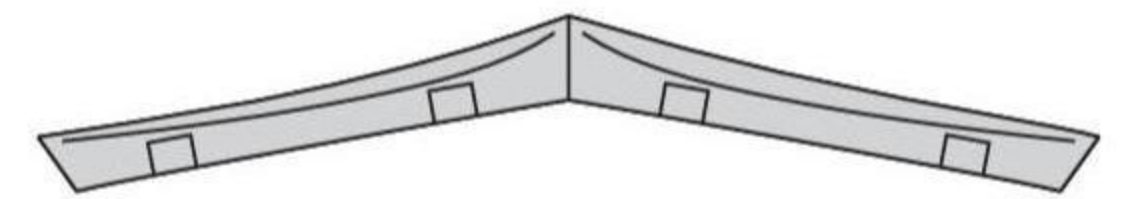

53

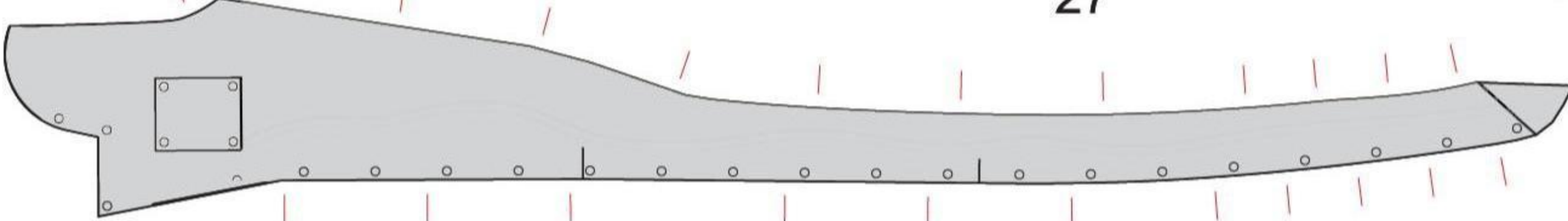

31

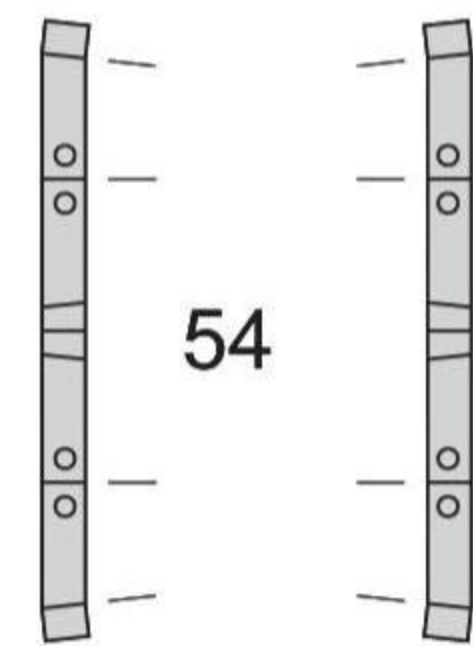

54

1/32 Scale P-51 D MUSTANG

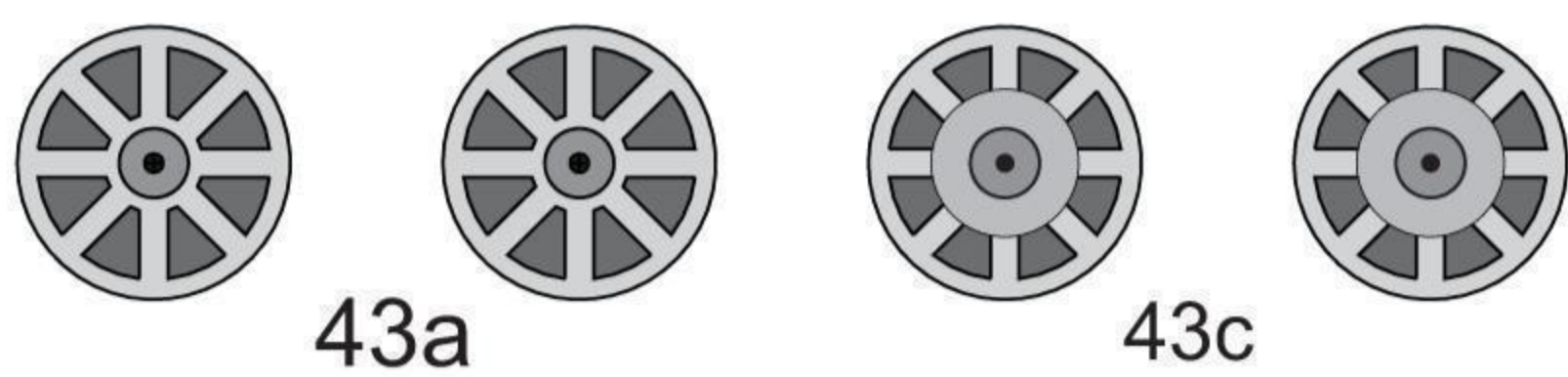
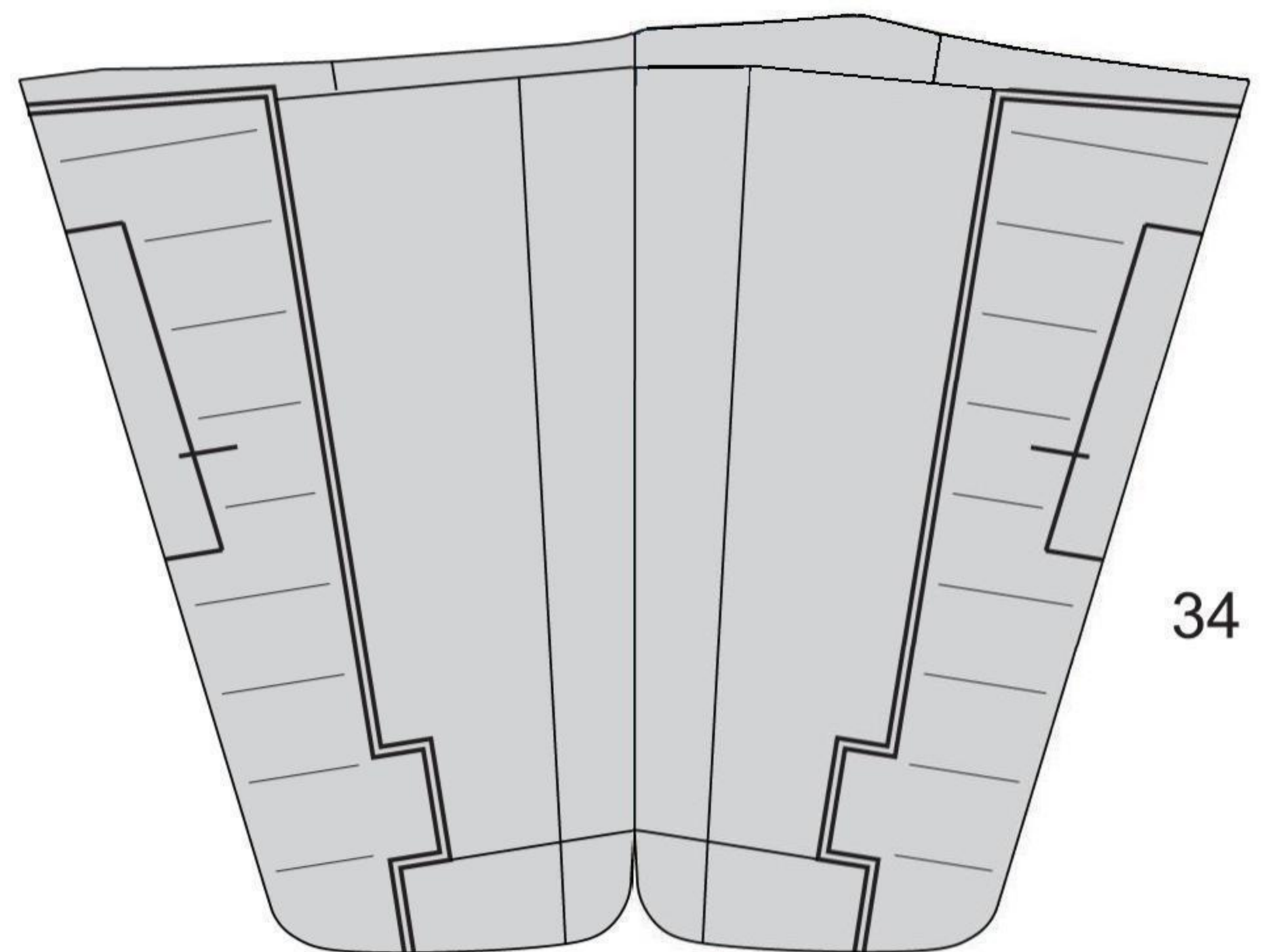
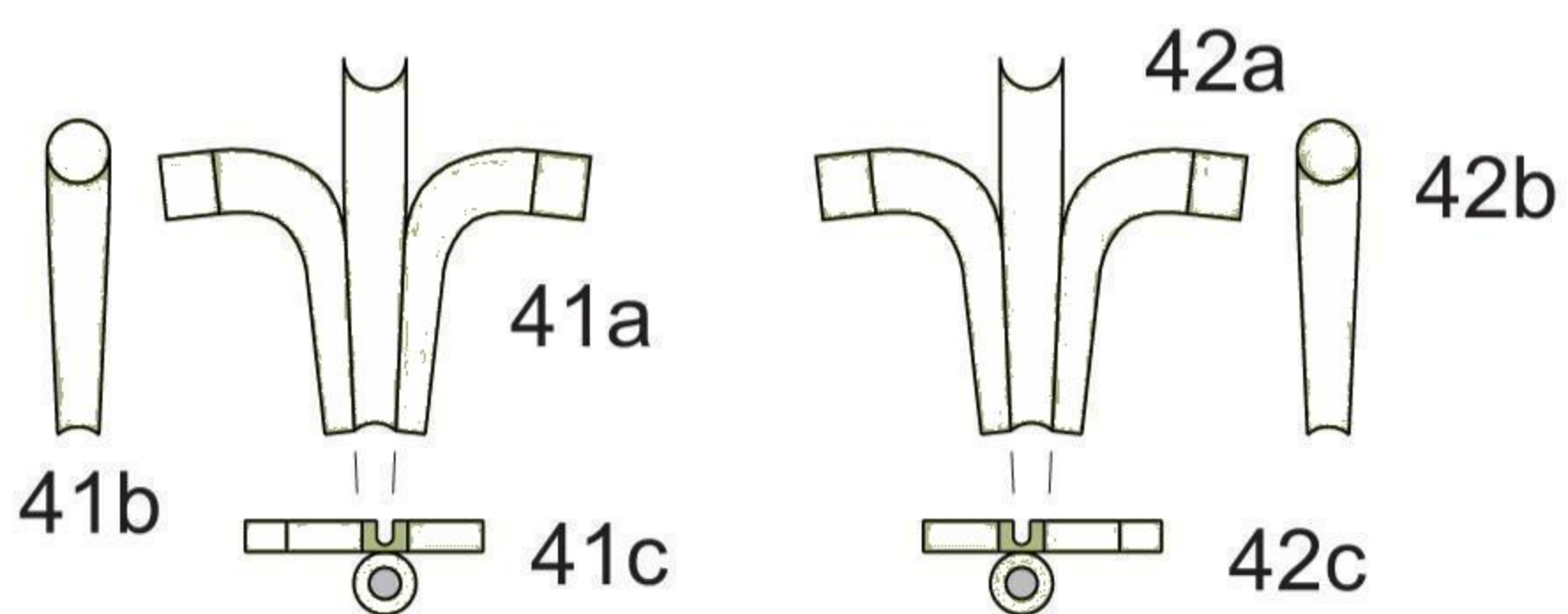
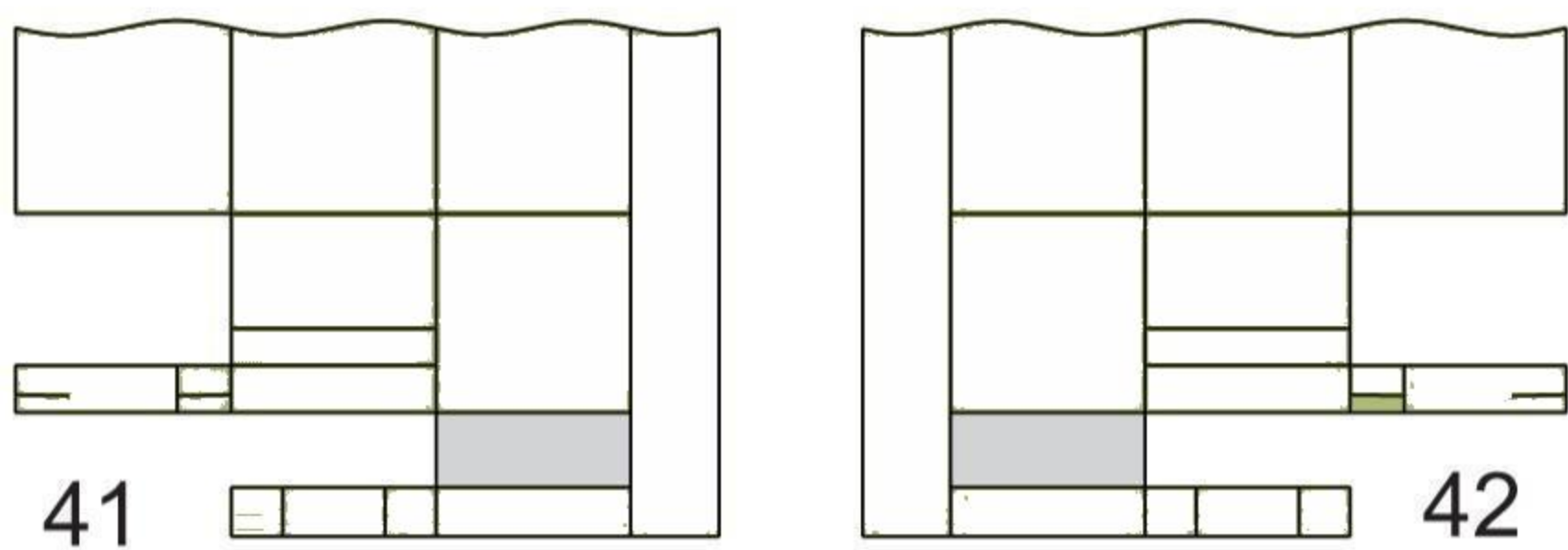
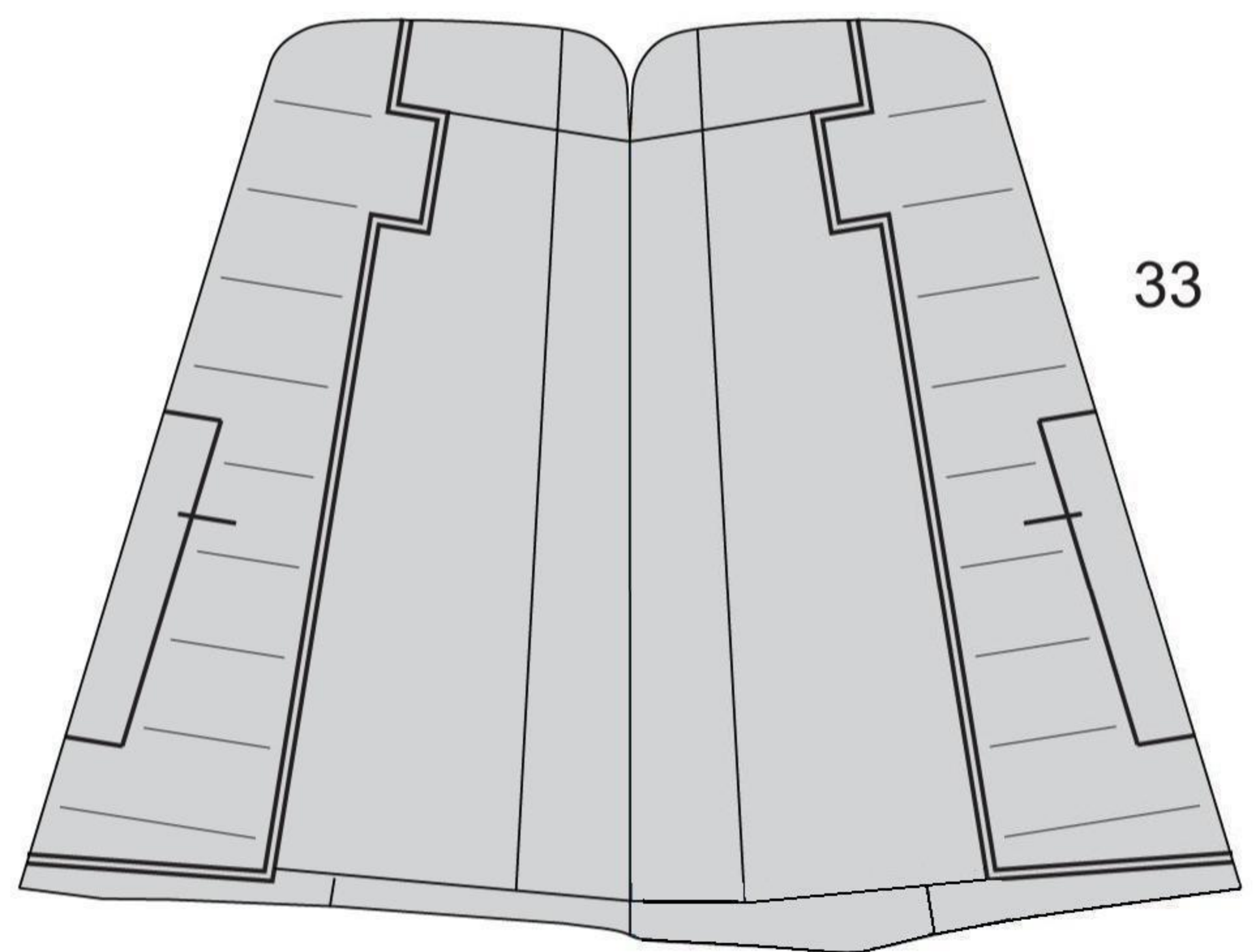
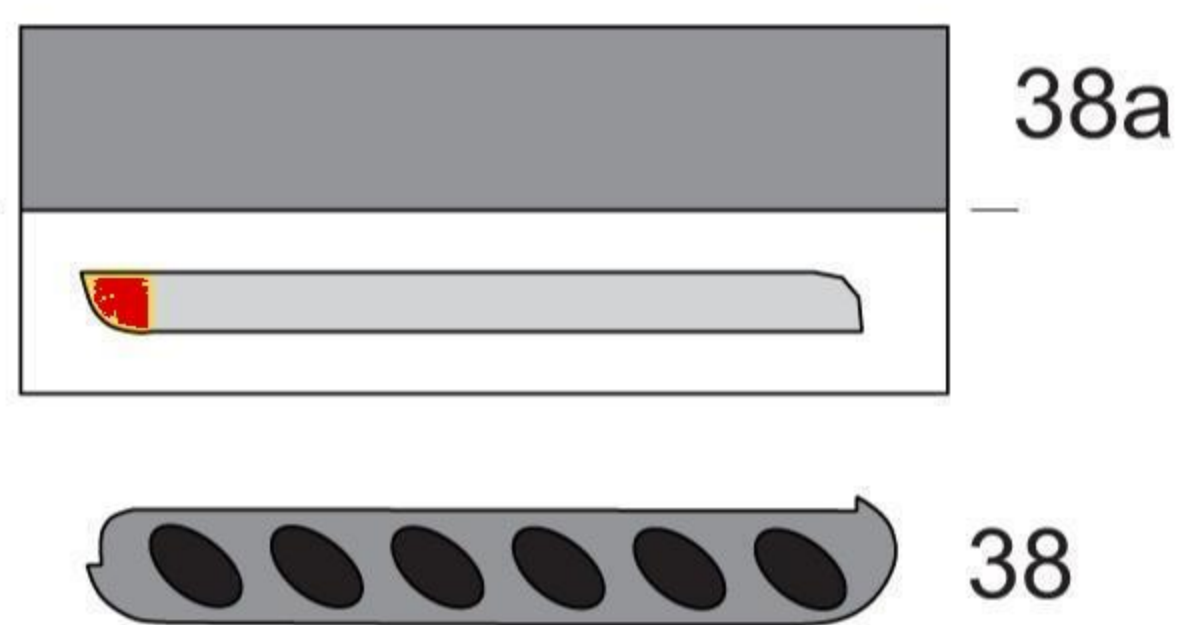
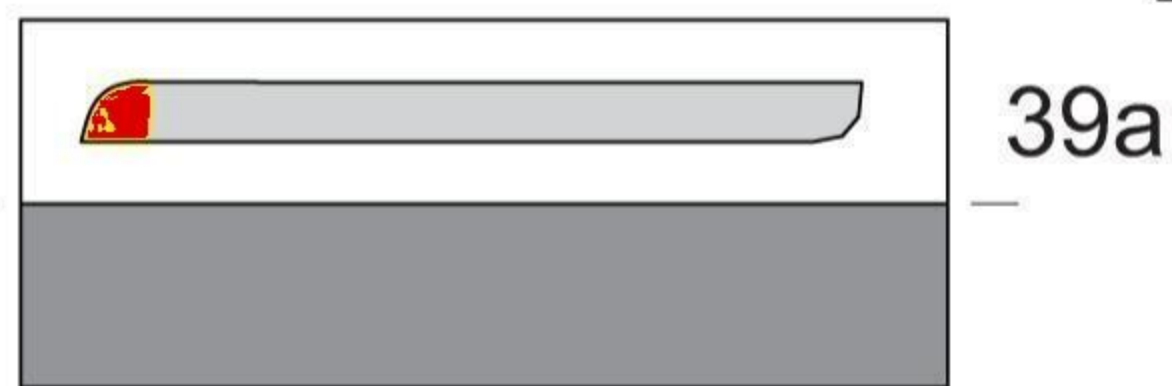
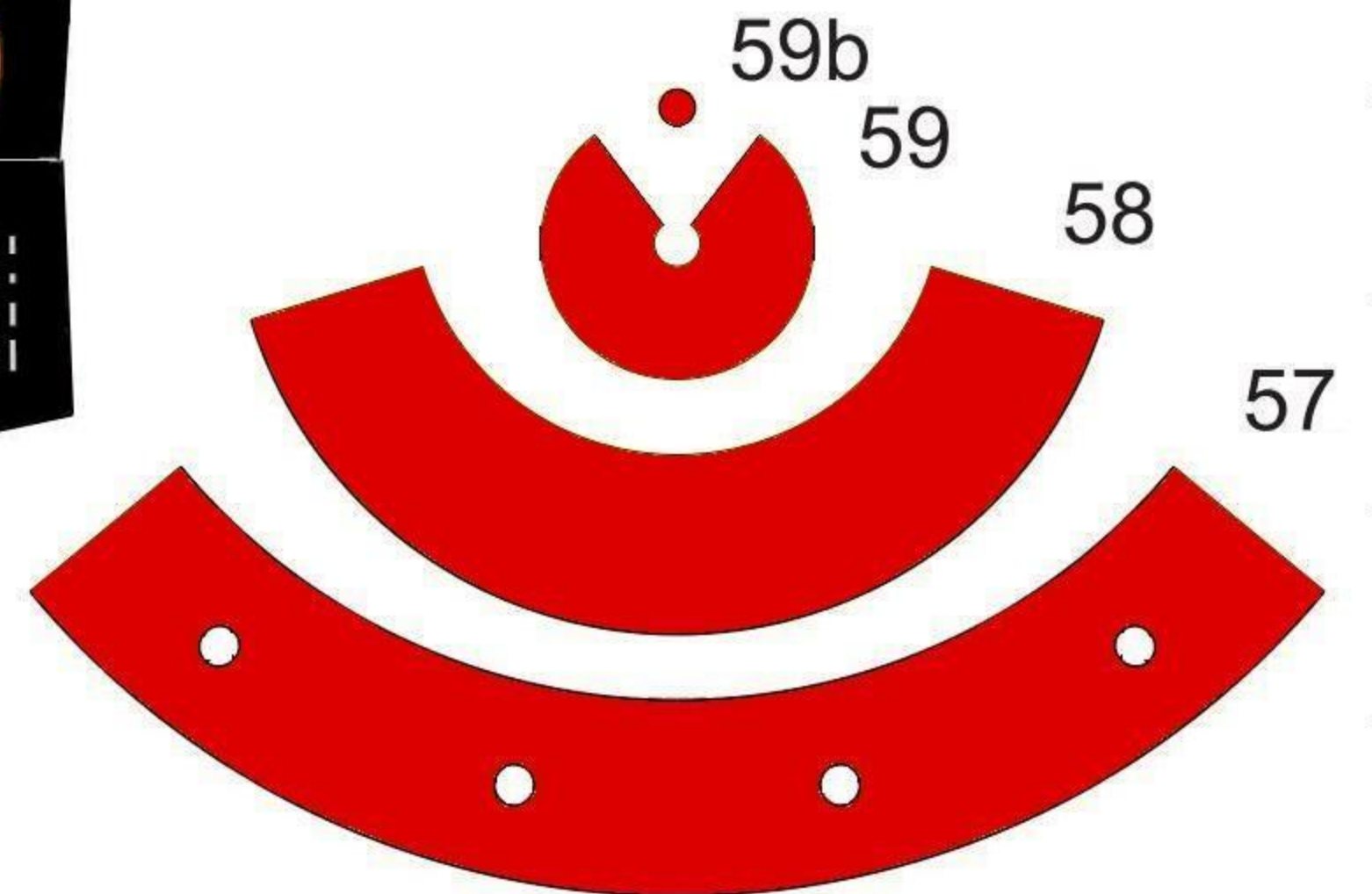
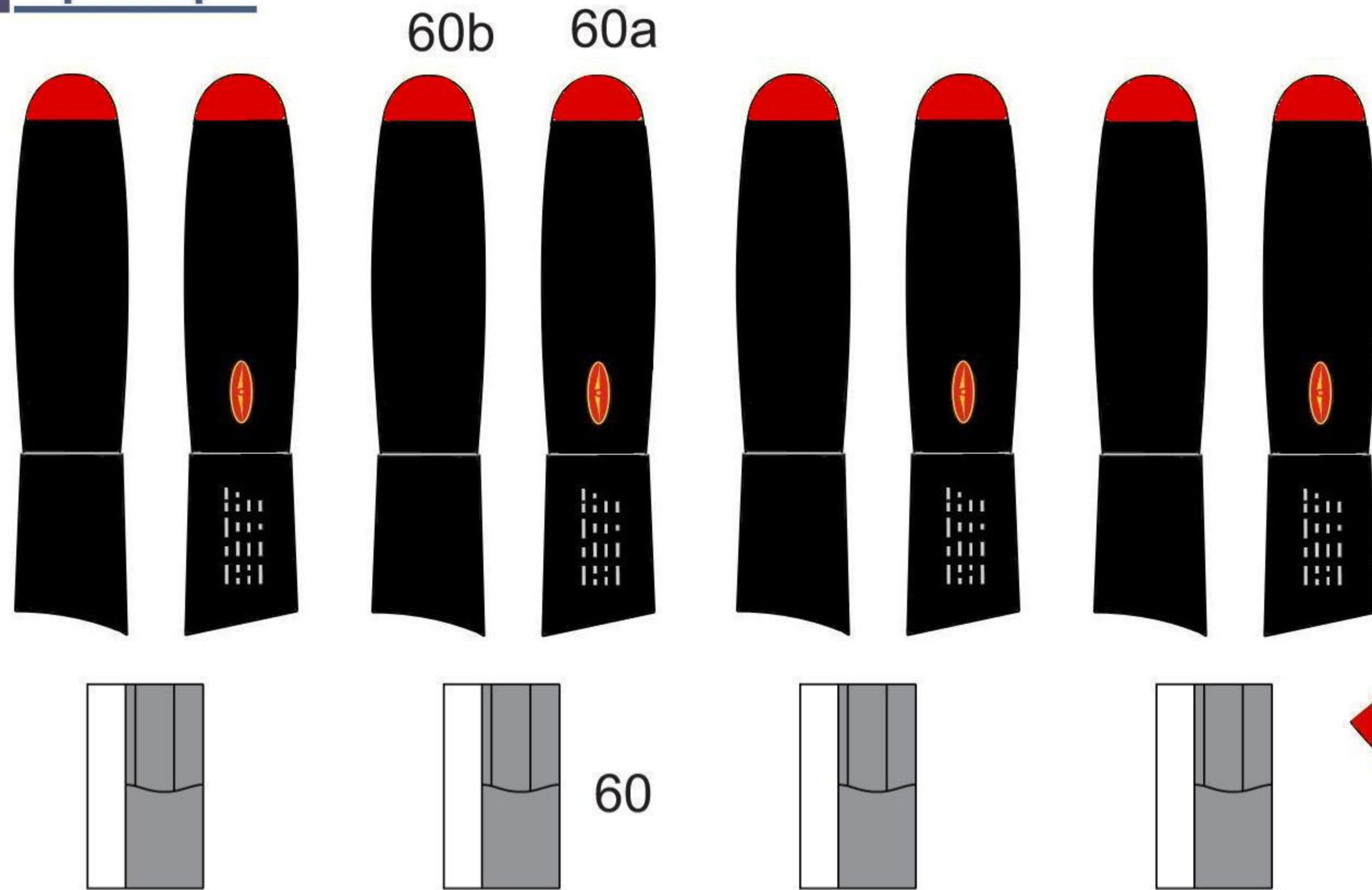

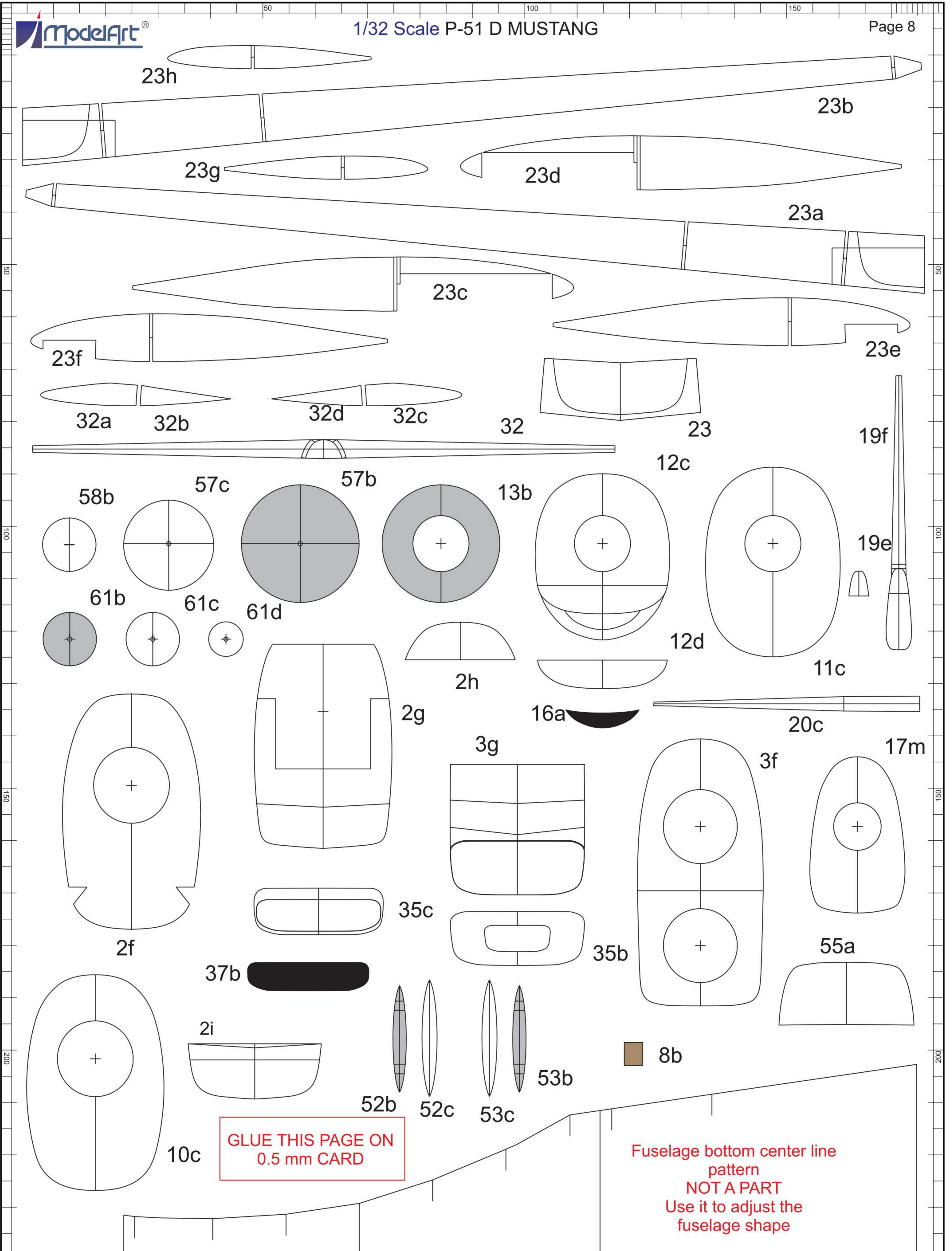

GLUE THIS PAGE ON
0.5 mm CARD

Fuselage bottom center line
pattern
NOT A PART
Use it to adjust the
fuselage shape

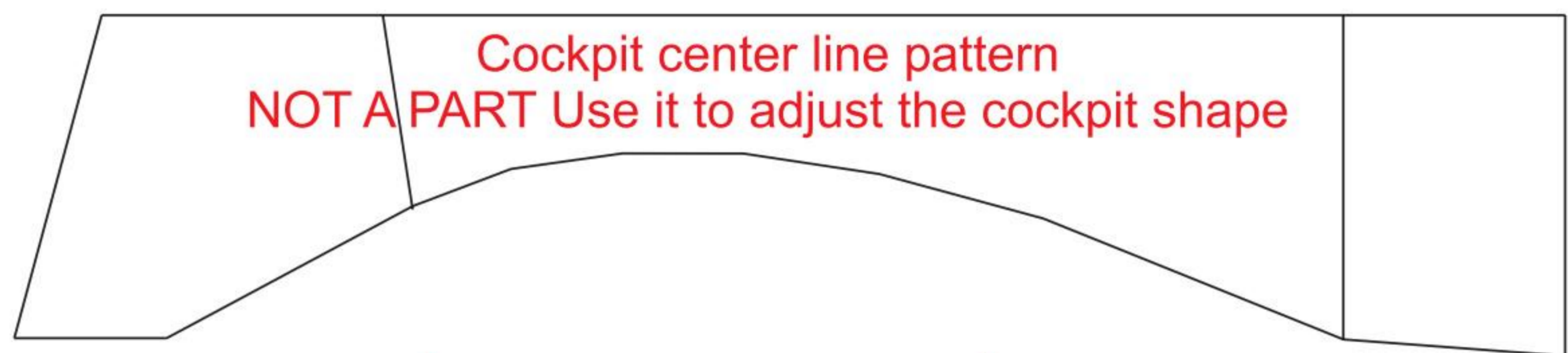
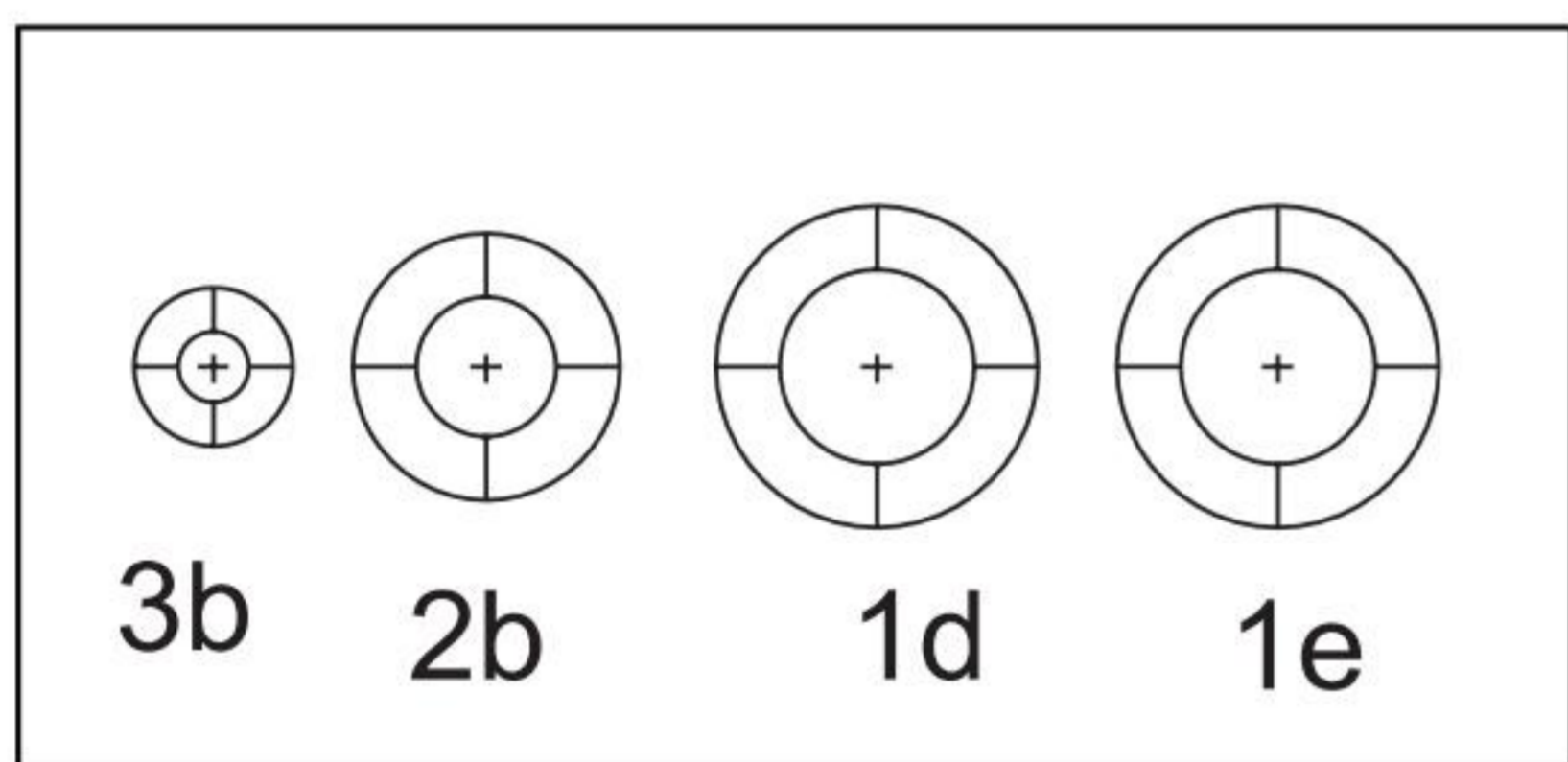
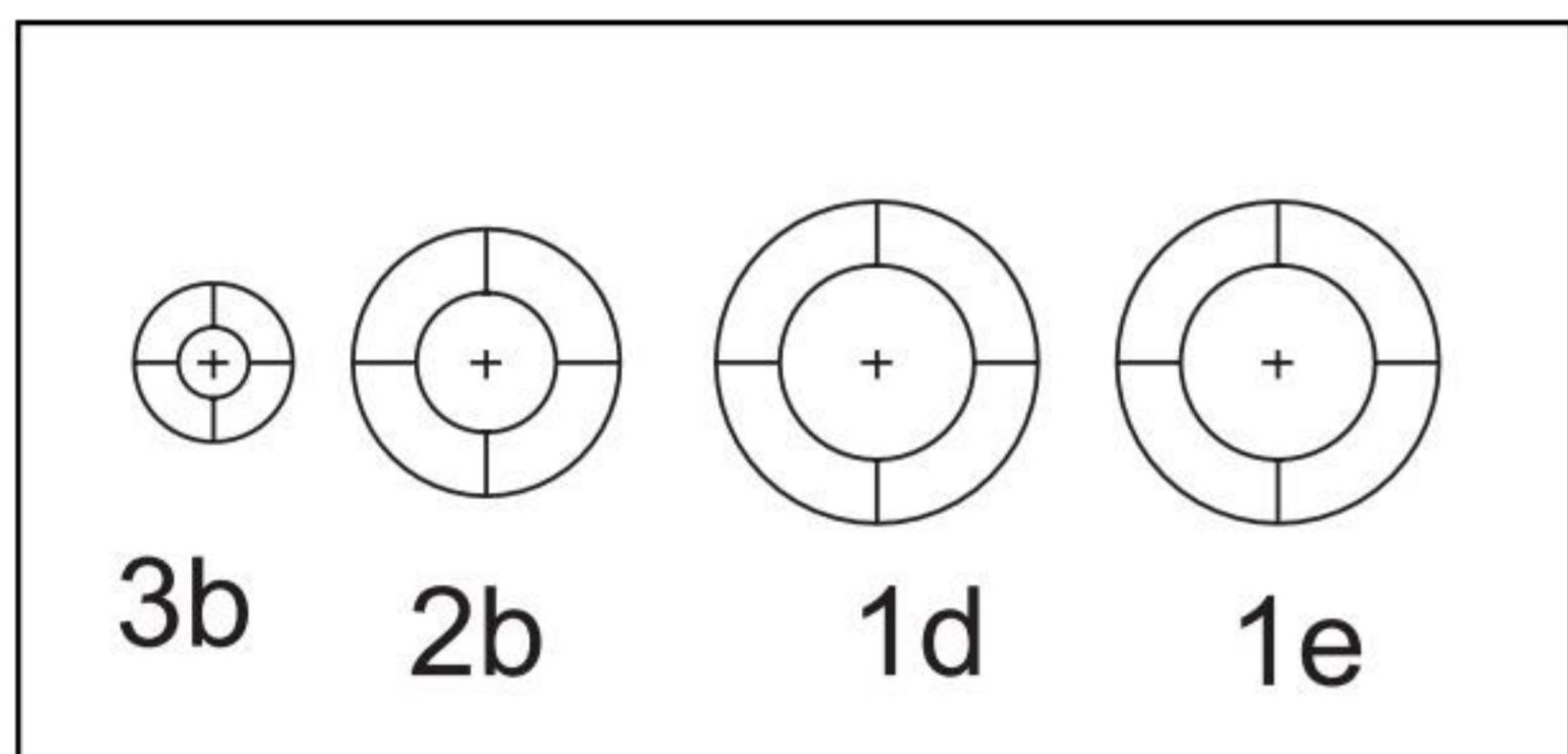
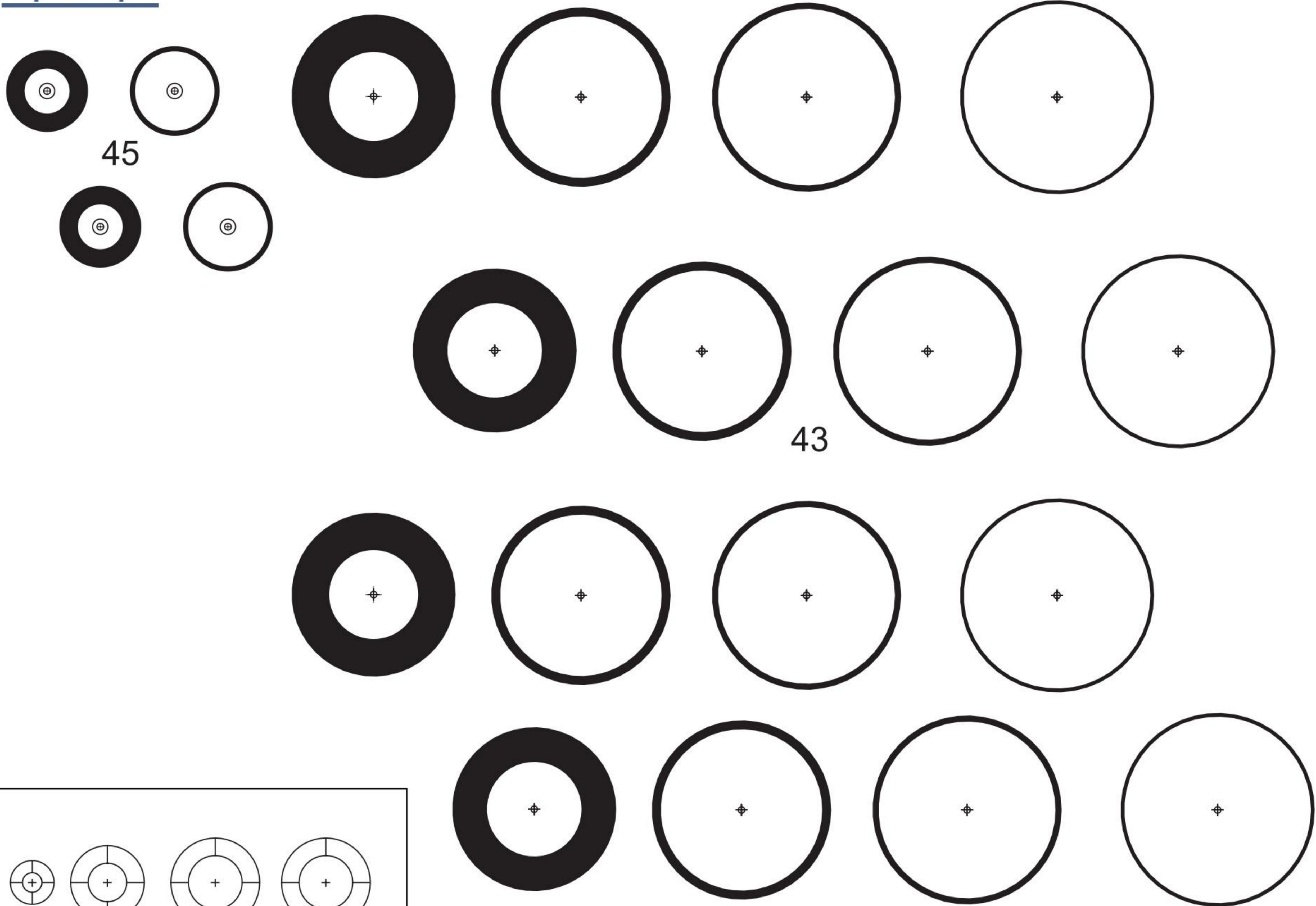

**GLUE THIS PAGE ON
0.5 mm CARD**

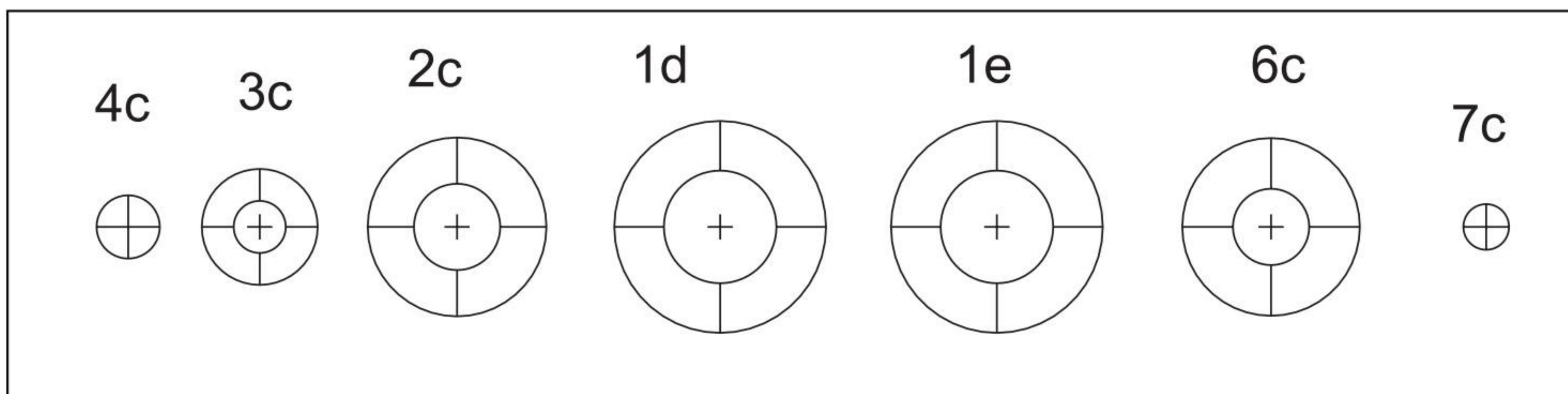
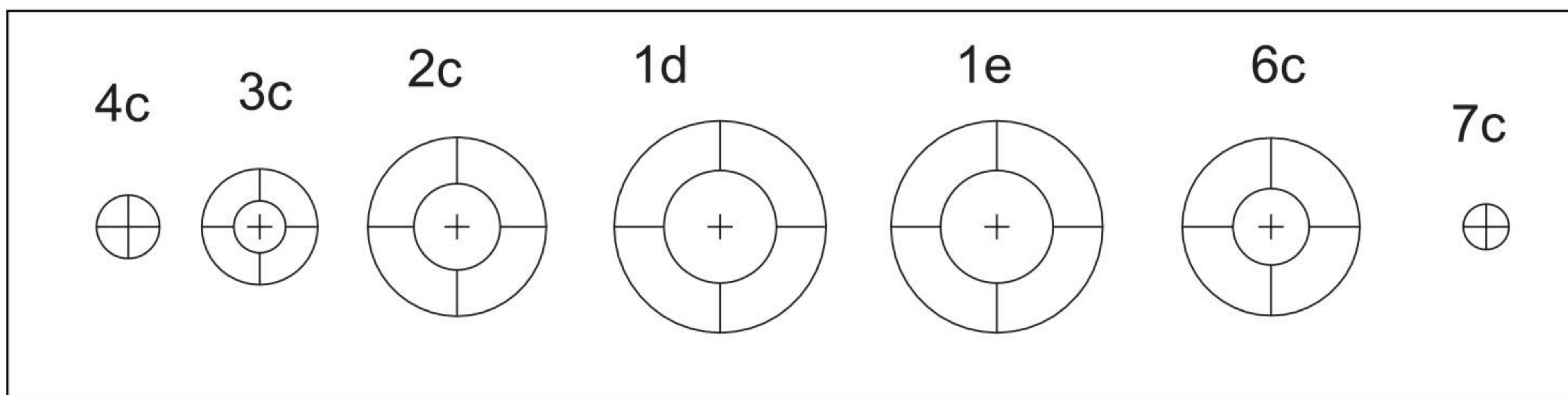

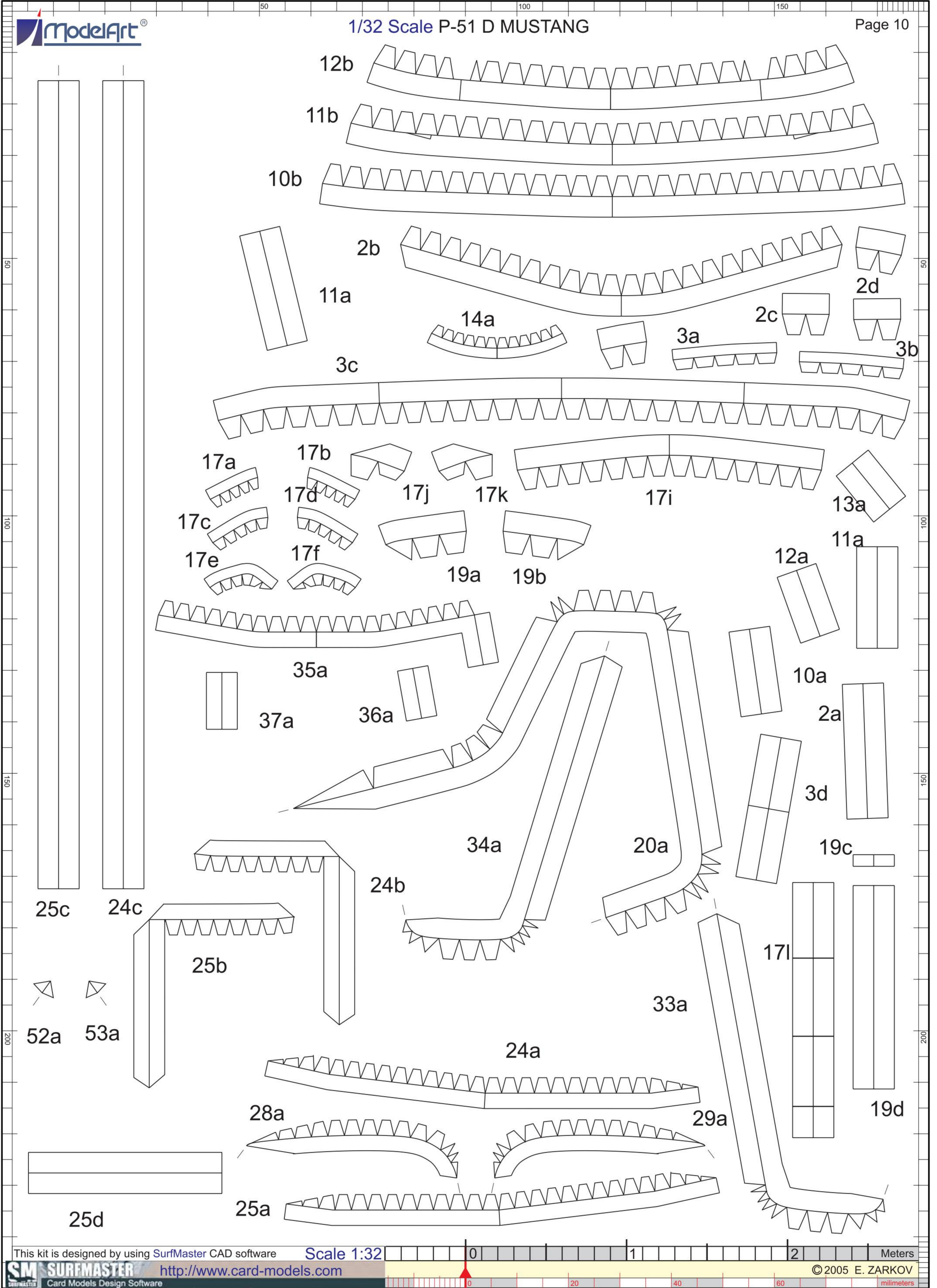

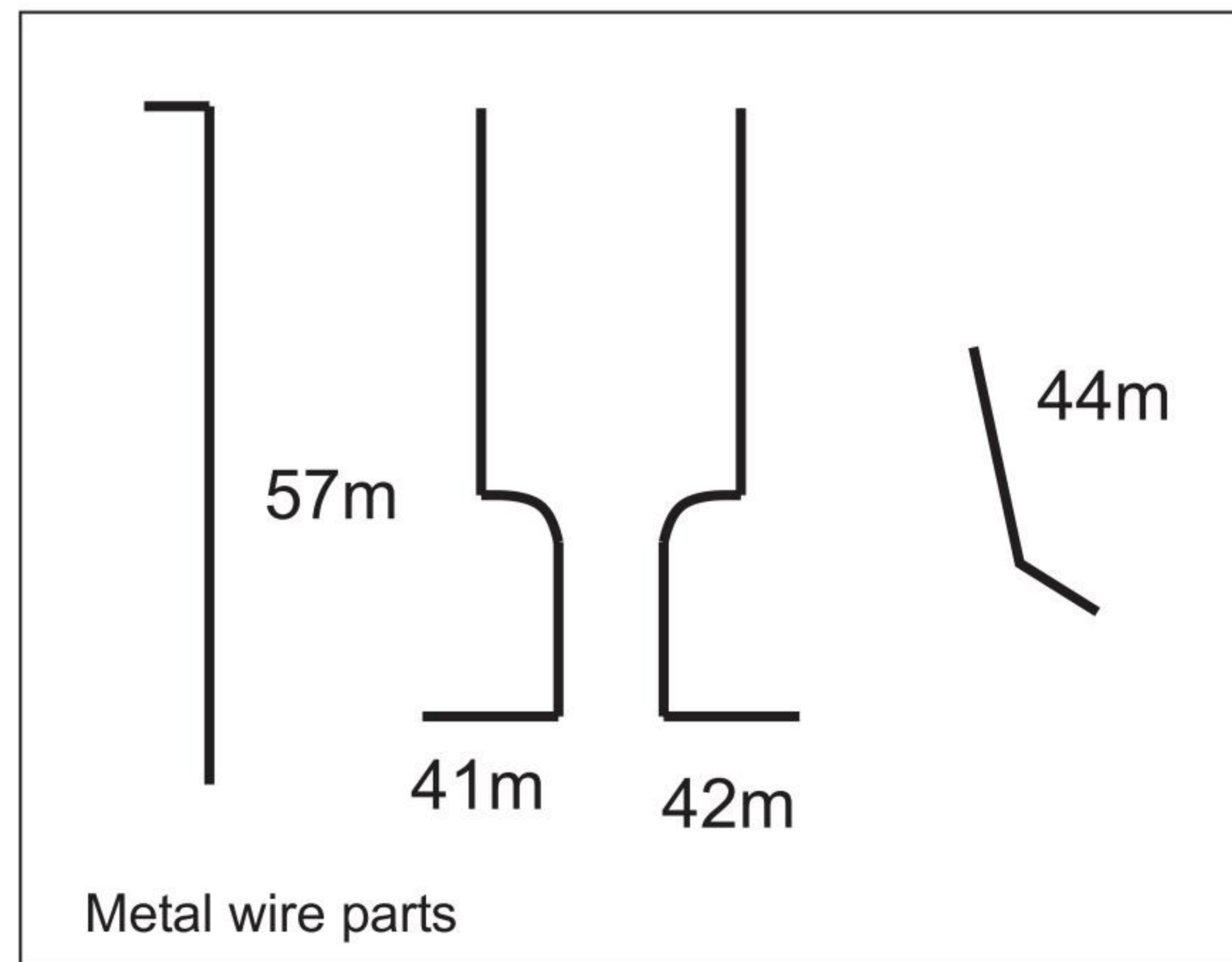
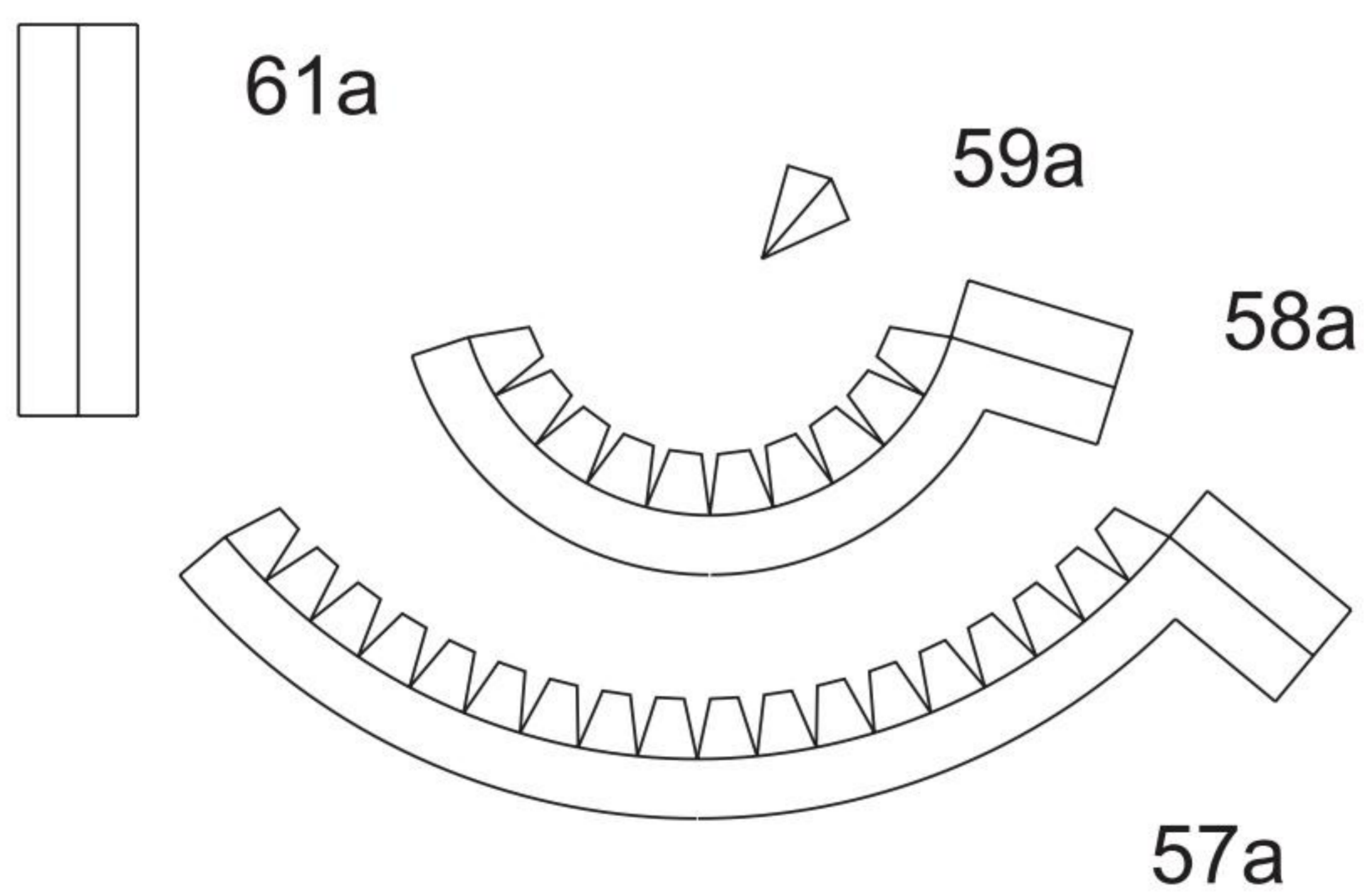
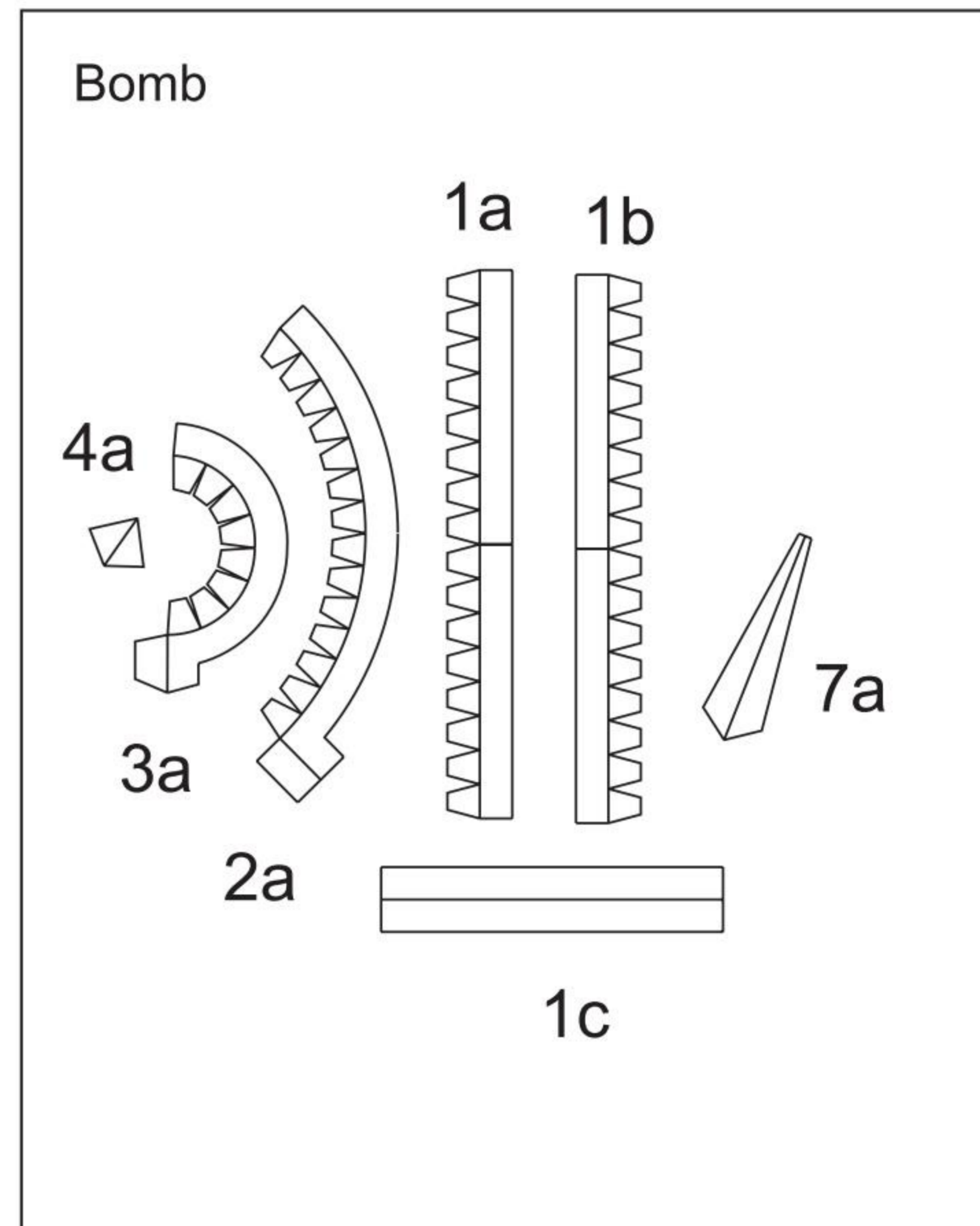
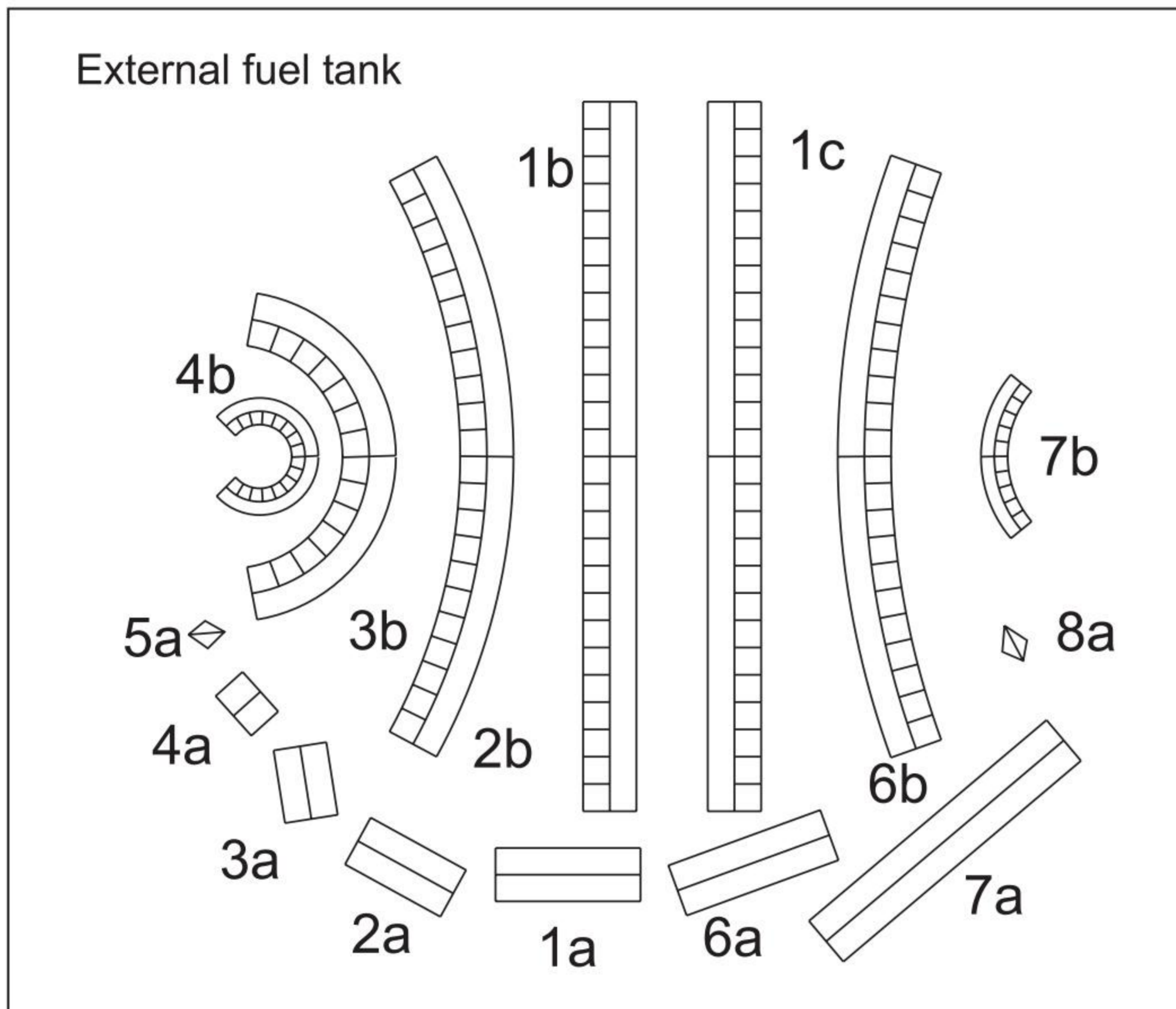
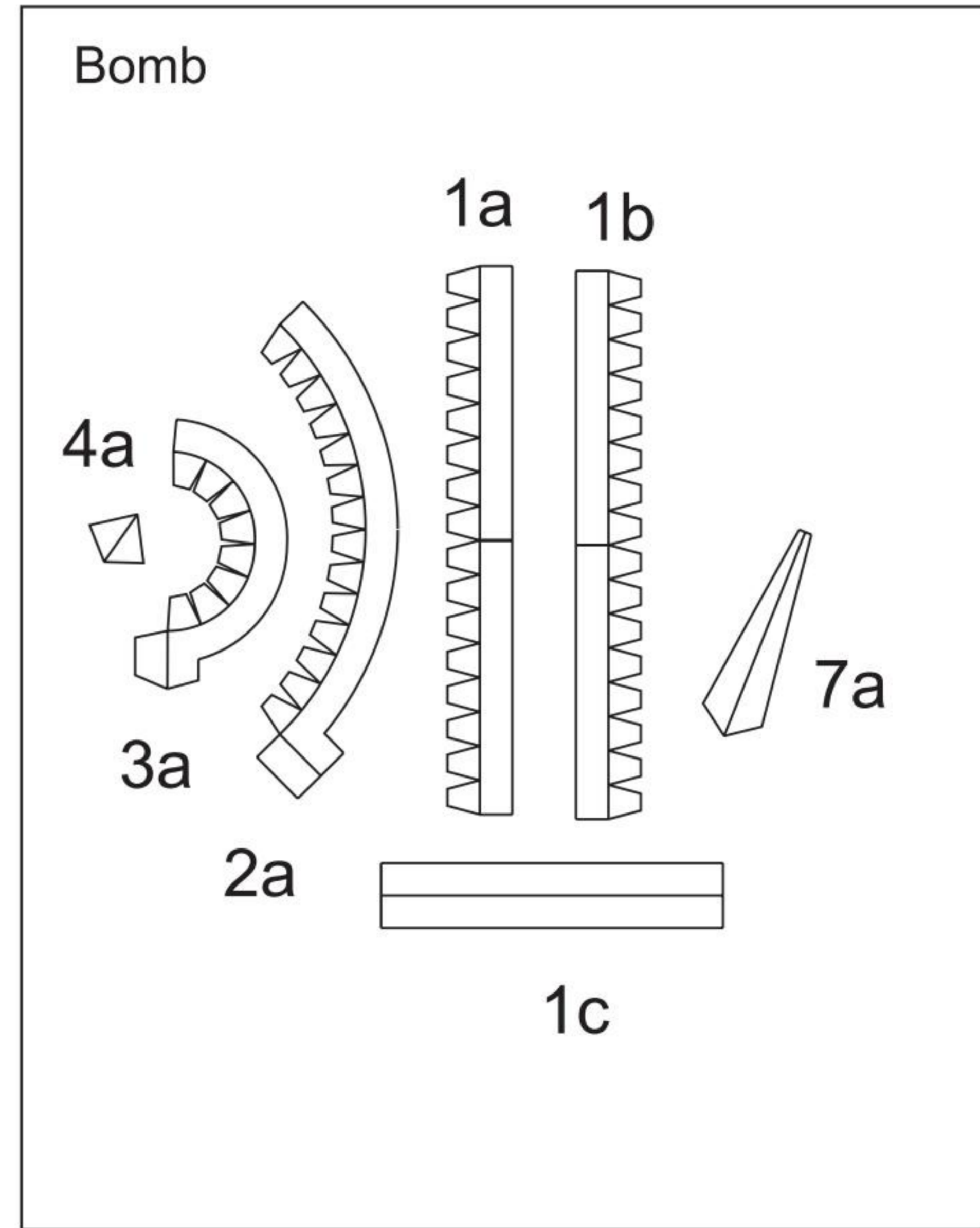
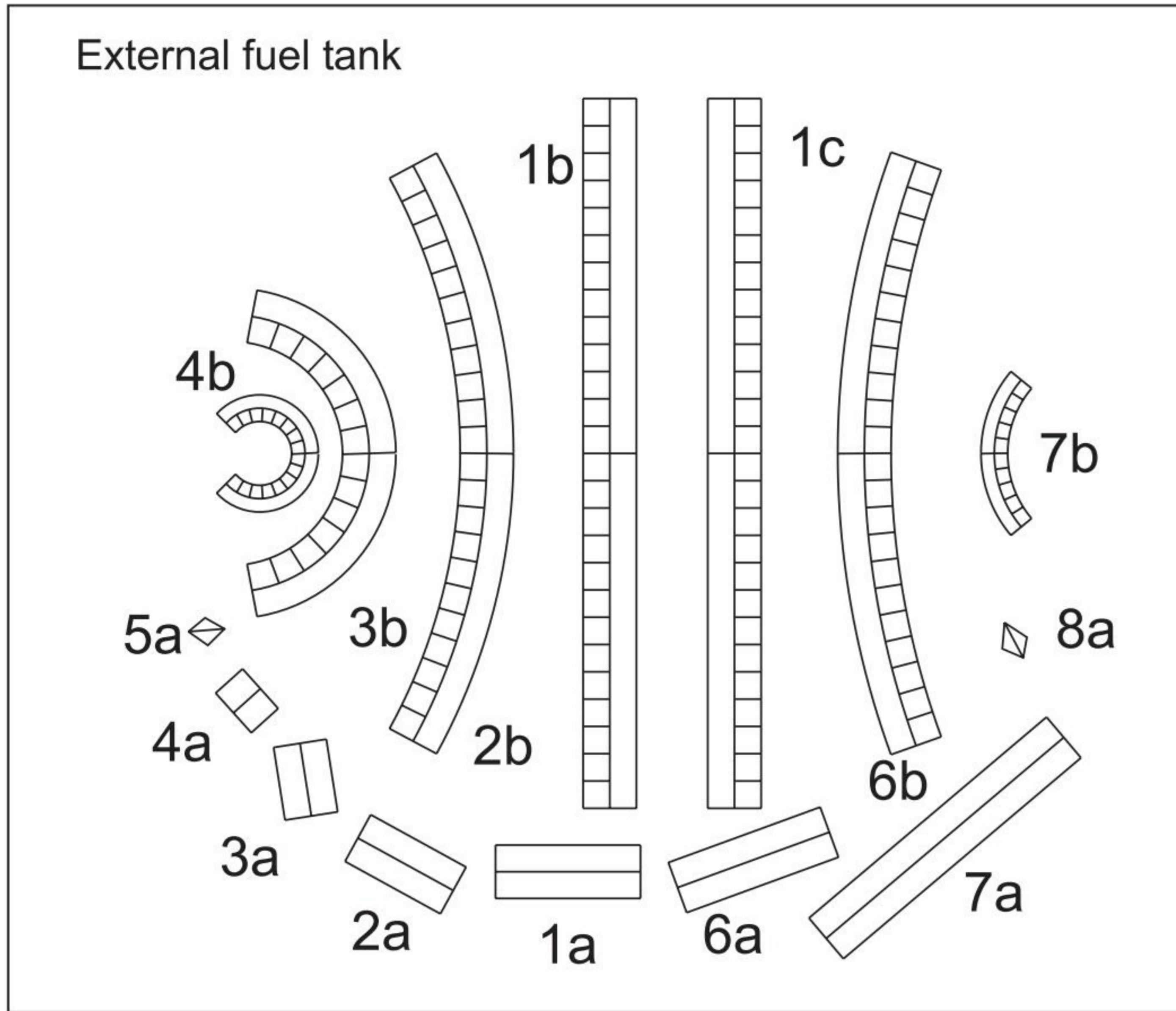

1/32 Scale P-51 D MUSTANG

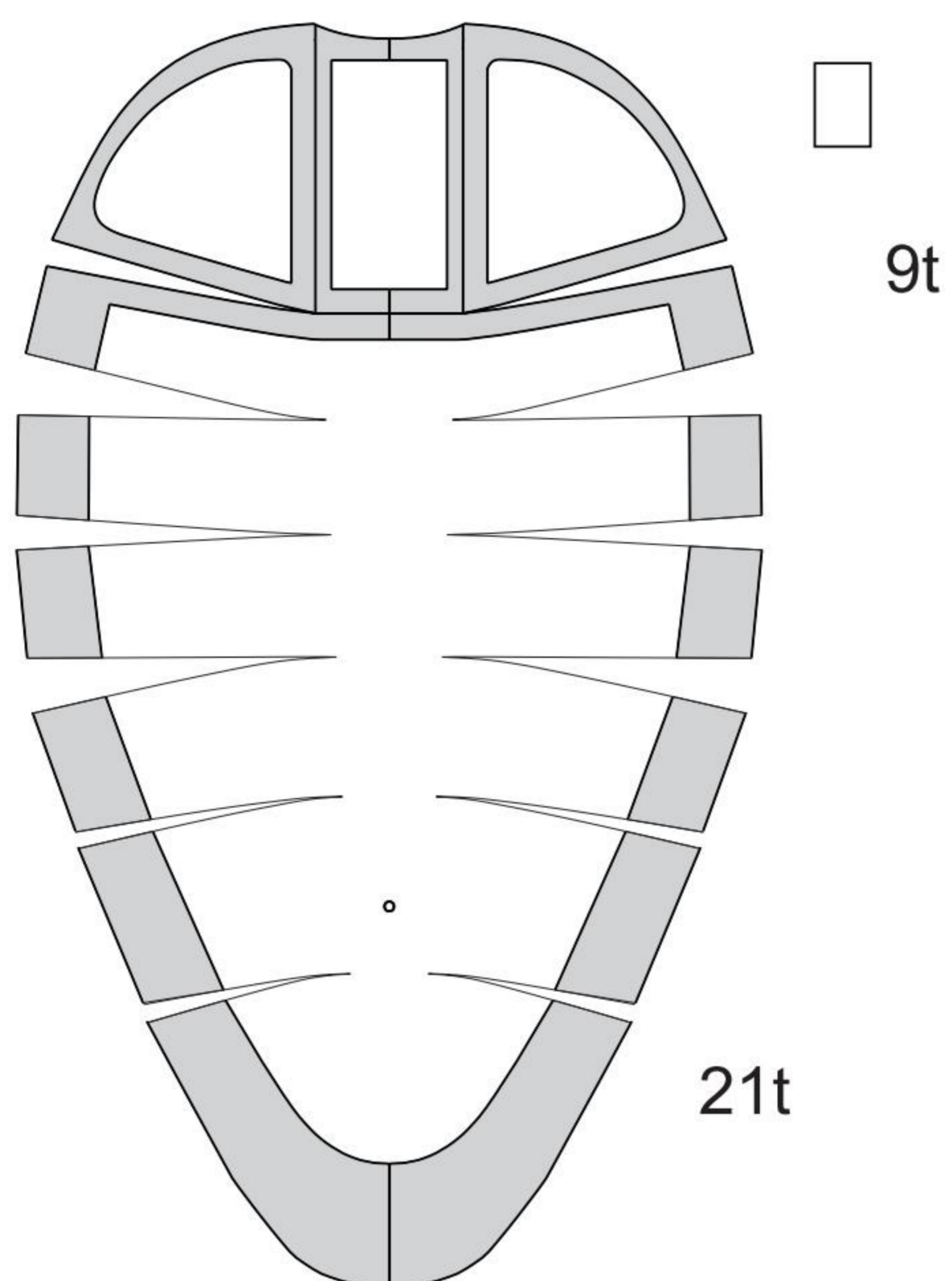

©2005 E. ZARKOV

TRANSPARENT PARTS

WARNING

USE ONLY TERMOPROOF
SPECIAL TRANSPARENT FOIL
FOR LASER PRINTING
OF THIS PAGE
USING UNAPPROPRIATE MATERIAL
CAN BADLY DAMAGE YOUR
LASER PRINTER!

1/32 Scale P-51 D MUSTANG

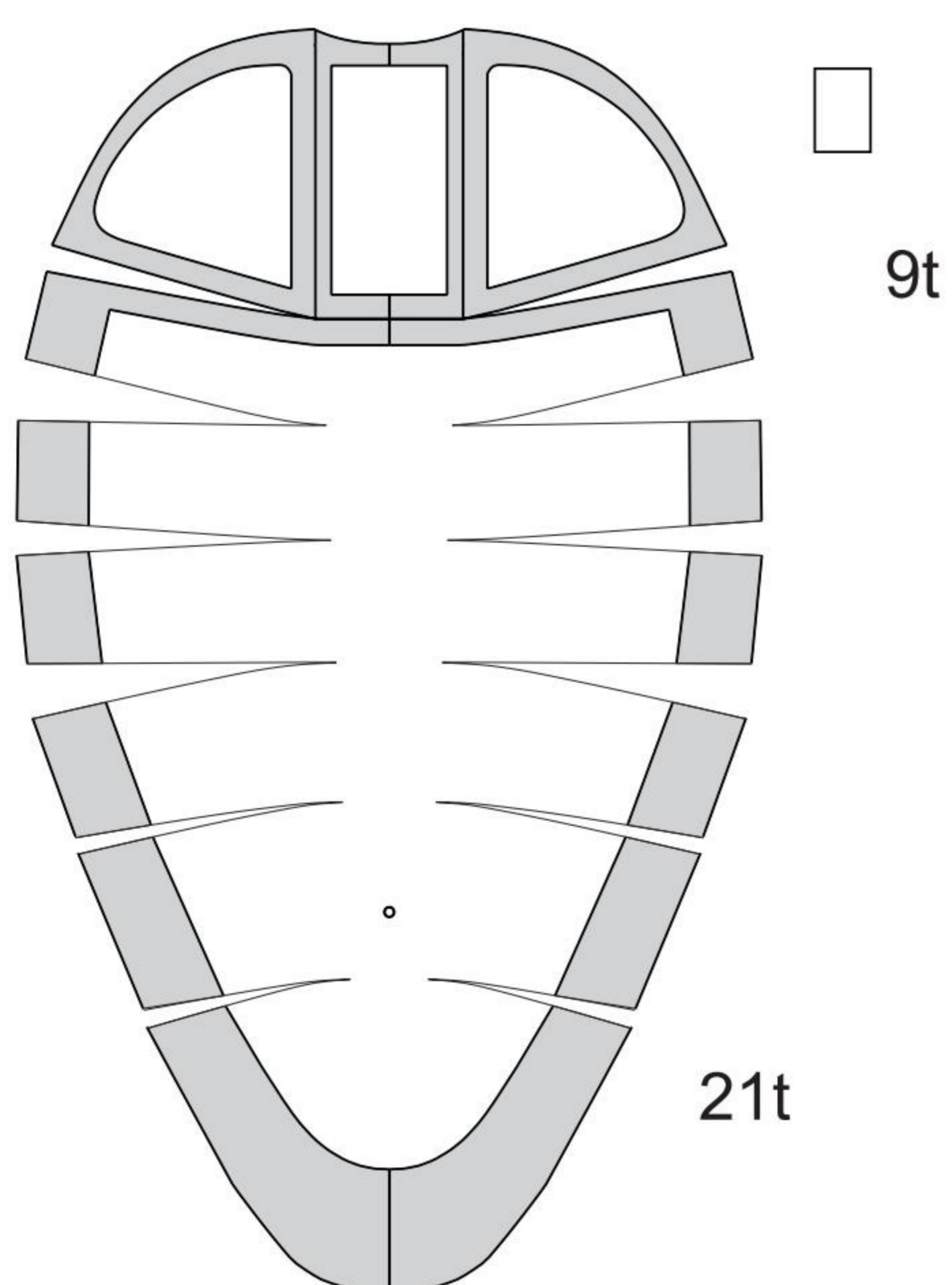

©2005 E. ZARKOV

1/32 Scale P-51 D MUSTANG

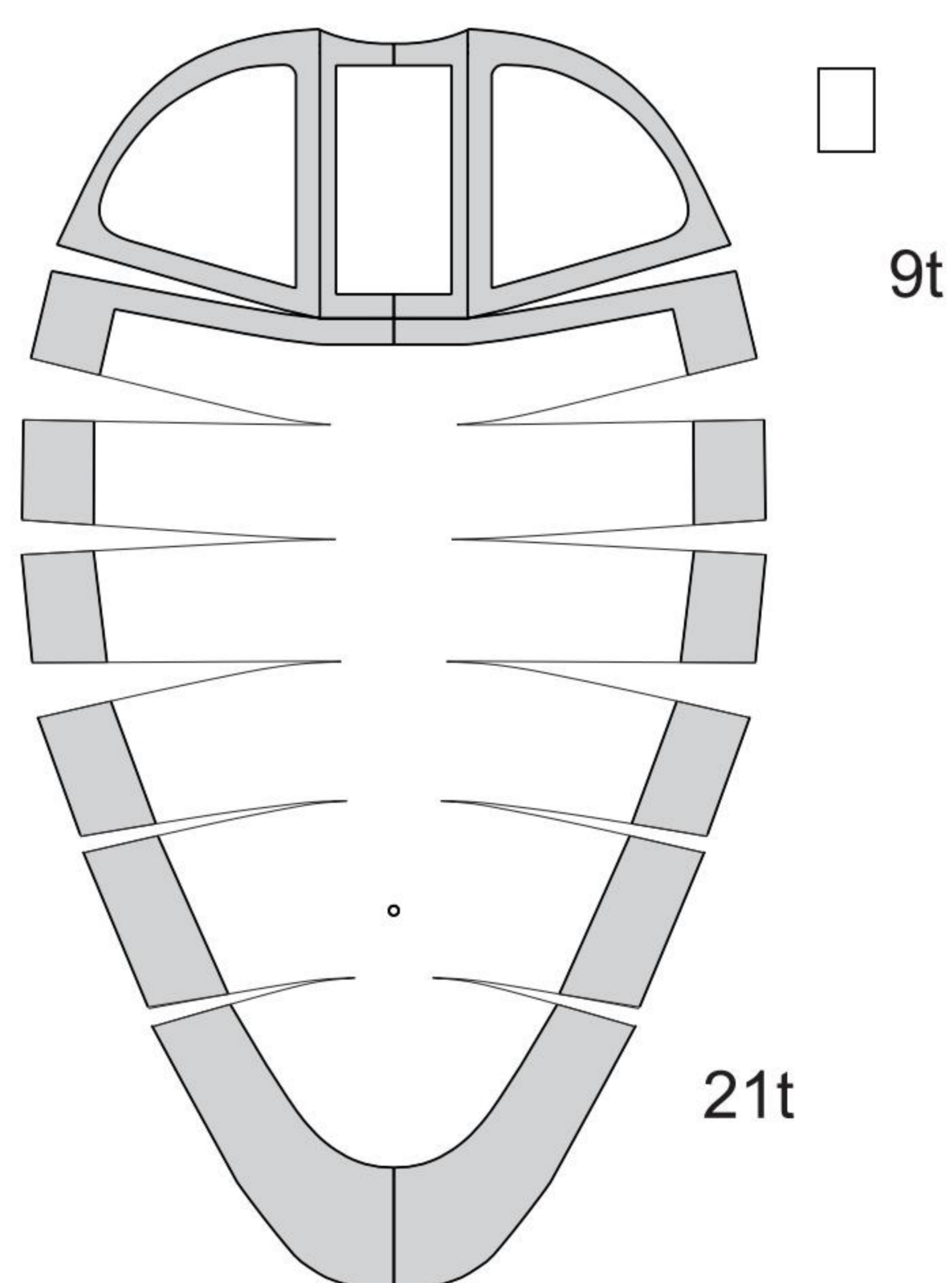

©2005 E. ZARKOV

P-51 D MUSTANG 375 FS

Scale: 1/32

PRINTING INSTRUCTIONS

CARD:	A4 160 g/m ²	7
PAPER:	A4 80 g/m ²	4
TRANSPARENCY:	A4 Transparency Foil WARNING USE ONLY TERMOPROOF SPECIAL TRANSPARENT FOIL FOR LASER PRINTING. USING UNAPROPRIATE MATERIAL CAN BADLY DAMAGE YOUR LASER PRINTER!	1
Instructions, Cover:	No any special requirements for the paper used	7
HEAVY CARD:	A4 450 g/m ² Have a look at the PAPER pages containing the elements, that should be glued over card.	2
REMARK: All pages are in A4 European format. You can use LEGAL format instead of A4.		

All Files are in **PDF Format** (Adobe® Reader®).

If you do not have Adobe Acrobat Reader, download and install the reader by clicking the "**Get Adobe Reader**" button below.

MODEL CONTENTS

File No:	File Name:	Material:
01	page01_card.pdf	Card
02	page02_card.pdf	Card
03	page03_card.pdf	Card
04	page04_card.pdf	Card
05	page05_card.pdf	Card
06	page06_card.pdf	Card
07	page07_card.pdf	Card
08	page08_paper.pdf	Paper
09	page09_paper.pdf	Paper

10	page10_paper.pdf	Paper
11	page11_paper.pdf	Paper
12	page12_transparency.pdf	Transparency
13	page13_instructions.pdf	Instructions
14	page14_instructions.pdf	Instructions
15	page15_instructions.pdf	Instructions
16	page16_instructions.pdf	Instructions
17	page17_instructions.pdf	Instructions
18	page18_instructions.pdf	Instructions
19	page19_cover.pdf	Cover

END USER LICENSE AGREEMENT

This product is available for private use only.
Please read [END USER LICENSE AGREEMENT](#) carefully!

CONTACT INFORMATION

Card-Models: www.card-models.com
For general customer or technical-support information, please contact us at support@card-models.com.