APPROVED PENDING  
ORANGE DRAWINGLT. COL. *F. J. Ellsworth*  
ORD. CORP.

DATE OCT 19 1950

ORD. PART NO. 7265893

ITEM	NO. REQD.	MATERIAL	NOTE
HARRINGTON & RICHARDSON ARMS CO. WORCESTER, MASS.			
FRAME ASSEMBLY			
.22 CAL. HORNET SURVIVAL WEAPON			
MODEL 274			
PART & NO. FRAME ASSEMBLY #220		SCALE F1/4"	OPER. NO. <input checked="" type="checkbox"/>
DESIGNED BY	DATE	DRAWING NO.	
DETAILED BY A.S.W.	DATE 9-7-50	<b>C-294-220</b>	
TRACED BY	DATE		
CHECKED BY <i>LA</i>	DATE SEPT. 8-50		
APPROV. BY	DATE		
SHEET 1 OF 1 SHEETS			

C	CLASSIFICATION CANCELLED BY AUTHORITY OF OCM 33331	S.A.	15 SEPS4
B	CHANGED; A294-190 TO A294-195, 7265742 TO 7266150	S.A.	1-7-52
A	REMOVED NOTES SILVER SOLDER, ADDED GRD. PT. NOS.	S.A.	10-13-50
	REVISIONS	BY	DATE

FRACTIONAL DIMENSIONS  $\pm .005$  UNLESS SPECIFIED OTHERWISE

PROTECTIVE FINISH  
TYPE II CLASS A  
AT ASSEMBLY  
7265773

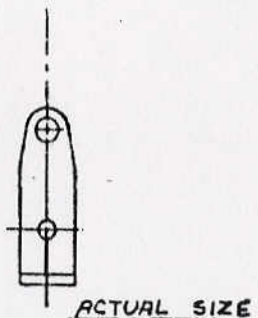

ACTUAL SIZE

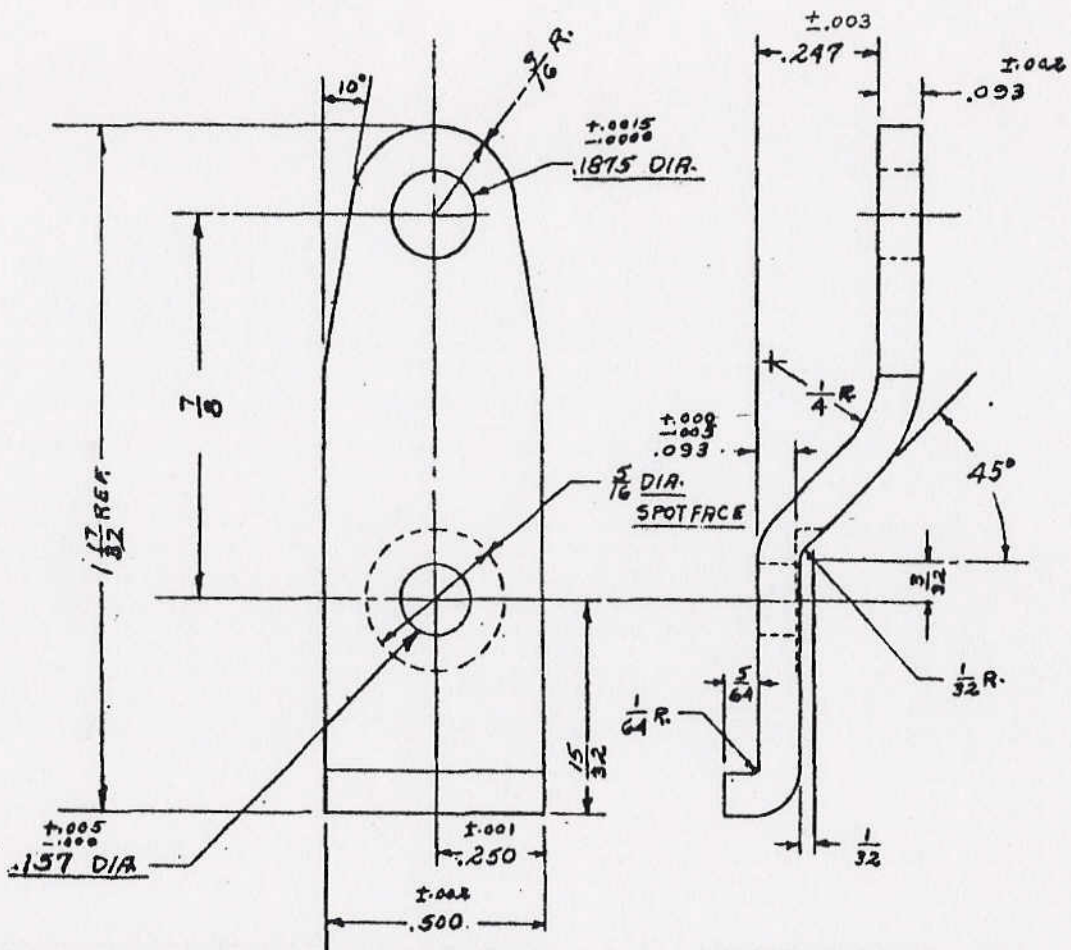

APPROVED PENDING  
ORDNANCE DRAWING  
LT. COL. *William*  
GRD. CORP  
DATE OCT 12 1950

ORD. PART NO. 7265894

89	1	A.I.S.I. 1010	.093 <sup>±.002</sup> STOCK
ITER	NO. REGD.	MATERIAL	SIZE
HARRINGTON & RICHARDSON ARMS CO. WORCESTER, MASS.			
<b>SAFETY LEVER</b> "GAMESTER" 12 GA. BOLT ACTION SHOTGUN			
MODEL 348			
PART & NO. SAFETY LEVER "89"		SCALE 4:1	OPER. NO. ~
DESIGNED BY	DATE	DRAWING NO.	
DETAILED BY <i>026</i>	DATE <i>July 30-49</i>		
TRACED BY	DATE	B-348-89	
CHECKED BY <i>10</i>	DATE <i>8.30.49</i>		
APPROV. BY	DATE	SHEET 1 OF 1 SHEETS	

REMOVE ALL BURRS, SHARP CORNERS AND EDGES.

CLASSIFICATION CANCELLED BY AUTHORITY OF OCM 32331		S.A.	8 SEP 54
D 157 DIA $\pm .005$ WAS 157 DIA $\pm .003$		S.A.	1-2-51
E ADDED; PROT. FIN. NOTE; REMOVED NOTE BLUED.		S.A.	10-13-50
F 1.46 WAS 1.48 & 1/8 WAS 3/16		101	10-11-49
G .247 WAS .278		101	10-5-49
REVISIONS	BY	DATE	
FRACTIONAL DIMENSIONS & UNLESS SPECIFIED OTHERWISE			

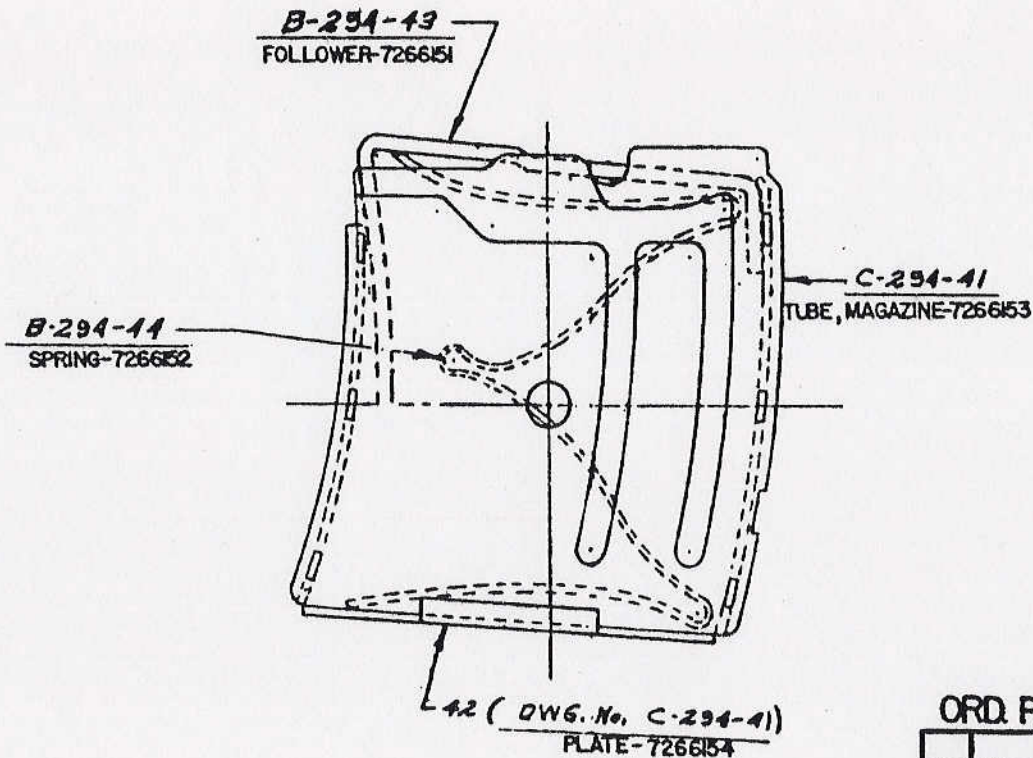

APPROVED PERFORMING  
ORDNANCE DRAWING *L.J.L.*  
LT. COL. *L.J.L.*  
ORIG. DESIG.  
DATE JAN 7, 1952

ORD. PART NO. 7265895

ITEM NO.	NO. REQD.	MATERIAL	SIZE
HARRINGTON & RICHARDSON ARMS CO. WORCESTER, MASS.			
<b>MAGAZINE ASSEMBLY</b> .82 CAL. HORNET SURVIVAL WEAPON			
FORM 294			
PROJ. & DES. NO. <i>7266154</i>		SCALE <i>2:1</i>	OPER. NO.
DESIGNED BY	DATE	DRAWING NO.	
DETAILED BY <i>L.J.L.</i>	DATE <i>11/21/51</i>	<b>B-294-61</b>	
CHECKED BY	DATE		

*TRANSFERRED DWG. SAME NO. DATED 1-1-52*

D			
C			
B	ADDED; SUPERSEDES OLD DWG. W/O CHANGE	S.A.	1-7-52
A	REVISIONS	BY	DATE

PHYSICAL DIMENSIONS & USE UNLESS SPECIFIED OTHERWISE

4

DO NOT SCALE THIS DRAWING

PROTECTIVE FINISH  
 (A) TYPE II CLASS A  
 U.S.A. 57-0-2

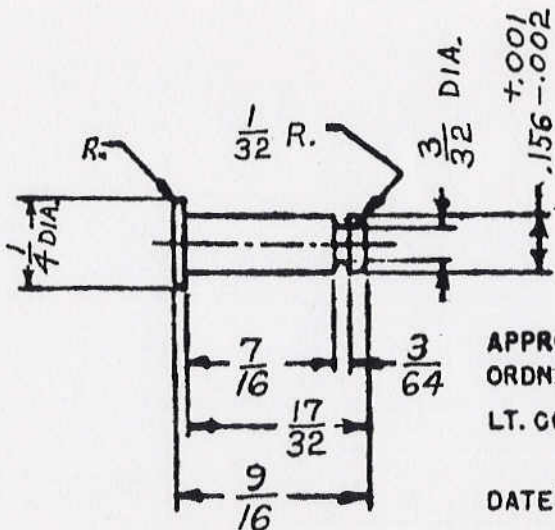

APPROVED PENDING  
 ORDNANCE DRAWING  
 LT. COL. *F. J. McElroy*  
 ORD. CORP  
 DATE OCT. 19, 1950

CYANIDE HARDEN

ORD. PART NO. 7265896

29	1	ALSI - C1018 (B)	
REV	NO. RECD.	INTERNAL	REV
HARRINGTON & RICHARDSON ARMS CO. WORCESTER, MASS.			
<u>TRIGGER PIN</u> 22 CAL. HORNET SURVIVAL WEAPON NO. 294			

(C) CLASSIFICATION CANCELLED BY AUTHORITY OF OCM 33331 (B) ALSI-CIGIB WAS B-1113 (A) PROTECTIVE FINISH ADDED.	S.A.	15 SEP 54	DESIGNED BY	DATE	DRAWING NO. <b>A-294-29</b> 63
	S.A.	1-7-52	DETAILED BY	A.S.B. DATE 7-10-50	
	S.A.	10-13-50	TRACED BY	DATE	
REVISIONS	BY	DATE	CHECKED BY	DATE 7/19/50	
FRACTIONAL DIMENSIONS 2 .005 UNLESS SPECIFIED OTHERWISE			APPR. BY	DATE	SHEET 1 OF 1 SHEETS

DO NOT SCALE THIS DRAWING

Ⓐ PROTECTIVE FINISH  
TYPE II CLASS A  
U.S.A. 57-0-2

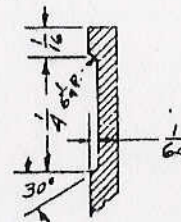

SECTION A-A

APPROVED PENDING  
ORDNANCE DRAWING

LT. COL. *F. McElroy*  
ORD. CORP

DATE OCT. 19, 1950

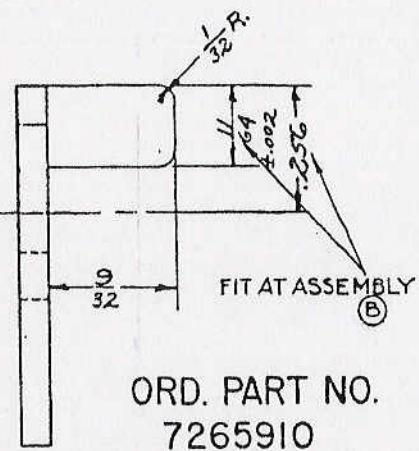
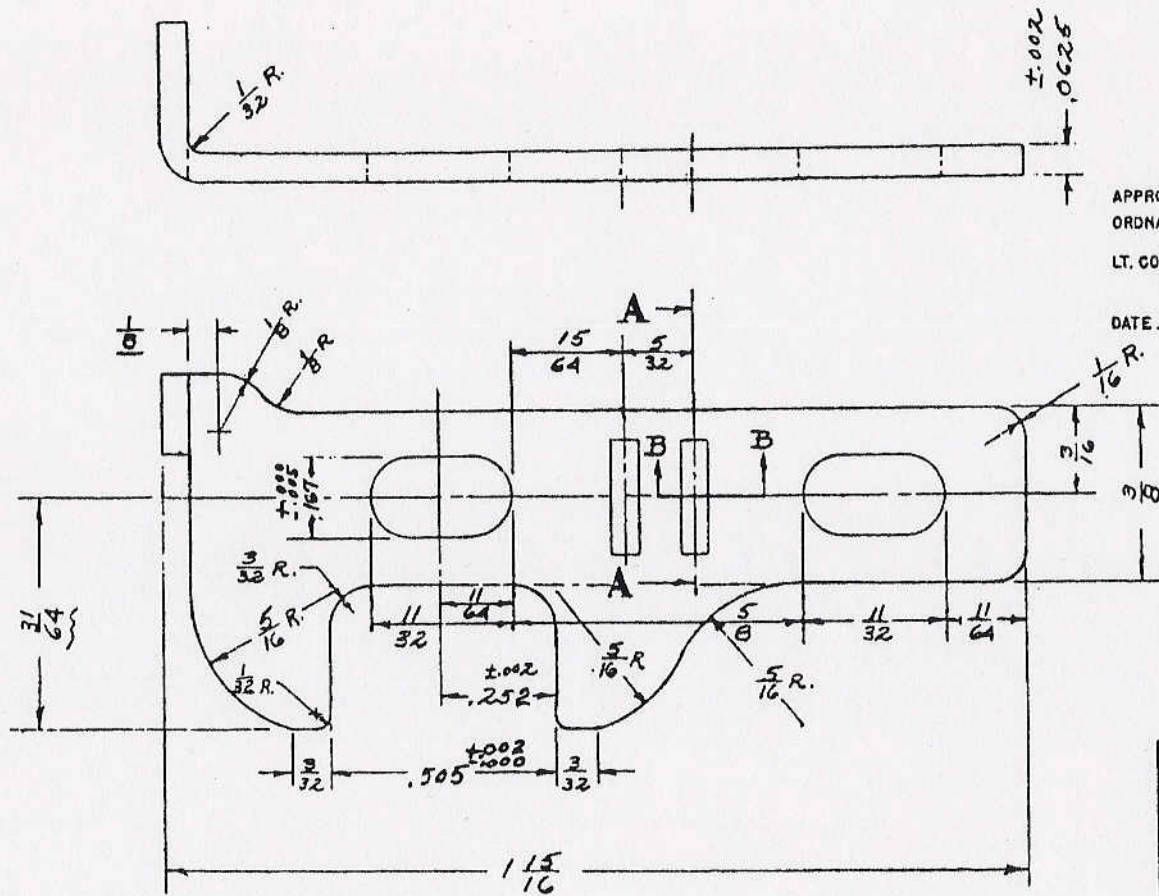

ORD. PART NO.  
7265910

Ⓐ REMOVE ALL BURRS, SHARP CORNERS & EDGES.

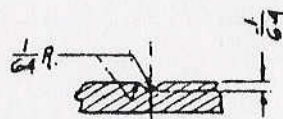

SECTION B-B

30	1	AISI 1010	1/16 THICK
ITEM	NO. REQ'D.	MATERIAL	SIZE
HARRINGTON & RICHARDSON ARMS CO. WORCESTER, MASS.			
<b>SAFETY LEVER SLIDE</b>			
MODEL # 865			
PART & NO. SAFETY LEVER #32		SCALE 4:1	OPER. NO. ~
DESIGNED BY	DATE	DRAWING NO.	
DETAILED BY <i>WSE</i>	DATE NOV. 11-48	B-865-32	
TRACED BY	DATE		
CHECKED BY <i>H</i>	DATE DEC. 16. 48	SHEET 1 OF 1 SHEETS	
APPRD. BY	DATE		

CLASSIFICATION CANCELLED BY AUTHORITY OF OCM 43331	S.A.	18SEP54
ADDED; NOTE, "FIT AT ASSEMBLY"	S.A.	1-2-51
PROTECTIVE FINISH ADDED; NOTE ADDED.	S.R.	11-13-50
REVISIONS	BY	DATE
FRACTIONAL DIMENSIONS & .008 UNLESS SPECIFIED OTHERWISE		



V

DO NOT SCALE THIS DRAWING

1/8 DIA. TOLERANCE  
UNLESS OTHERWISE NOTED.

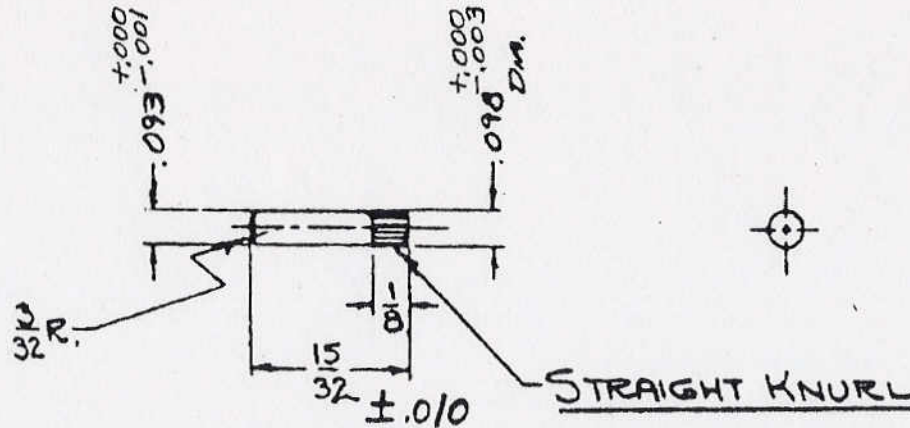

APPROVED PENDING  
ORDNANCE DRAWING  
COL *F. J. McIlhenny*  
ORD. CORP  
DATE JAN. 29, 1951

CYANIDE HARDEN

PROT. FINISH  
TYPE II CLASS A OR B  
U.S.A. SPEC. 57-0-2

ORD. PART NO. 7265962

		A.I.S.I. B-1113	.093" ± .001 DIA.
ITEM	NO. REQ.	MATERIAL	SIZE
HARRINGTON & RICHARDSON ARMS CO. WORCESTER, MASS.			
<u>FRONT SIGHT RETAINING PIN</u>			
MODEL 294			
PART & NO. FRONT SIGHT Ret Pin		SCALE 2:1	OPER. NO.
DESIGNED BY		DATE	DRAWING NO. <u>.66</u>  <u>A-294-360</u>
DETAILED BY A.S.B.		DATE 11-17-50	
TRACED BY		DATE	
CHECKED BY HEM		DATE 1-5-51	
APPROVED BY		DATE	SHEET 1 OF 1 SHEETS

REVISIONS	BY	DATE
C		
B		
A		

FRACTIONAL DIMENSIONS ± .005 UNLESS SPECIFIED OTHERWISE

DO NOT SCALE THIS DRAWING

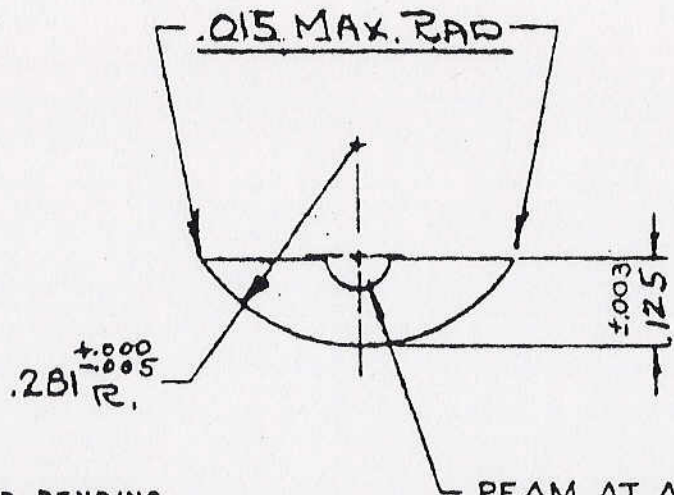

NOTE:- SHEARED EDGES MUST BE SMOOTH. CORNERS AND EDGES SHALL NOT BE ROUNDED TO EXCEED .010 RAD.

UNLESS OTHERWISE SPECIFIED.

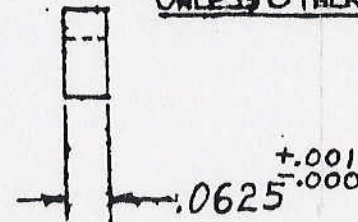

APPROVED PENDING  
ORDNANCE DRAWING  
COL. *F. McElharrow*  
ORD. CORP

REAM AT ASSEMBLY WITH  
B294-48(7265964 AND C294-8(7265718)

DATE JAN. 29, 1951

ORD. PART NO. 7265963

PROT. FINISH  
TYPE II CLASS A OR B  
U.S.A. SPEC. 57-O-2

370		SUBSTITUTE AISI C-1010	
		AISI C-1020	
ITEM	NO. RECD.	MATERIAL	QTY
HARRINGTON & RICHARDSON ARMS CO. WORCESTER, MASS.			
<u>FRONT SIGHT KEY</u>			
MODEL 294			
PART & NO. FRONT SIGHT KEY 370		SCALE 4:1	OPER. NO. ~
C		DESIGNED BY	DATE
B		DETAILED BY R.E.S.	DATE 1-2-51
A	SUBSTITUTE MAT. ADDED	SA	1-7-52
REVISIONS		BY	DATE
		CHECKED BY H.E.M.	DATE 1-5-51
FRACTIONAL DIMENSIONS ± .005 UNLESS SPECIFIED OTHERWISE		APPRD. BY	DATE
		DRAWING NO. 67	
		<b>A-294-370</b>	
		SHEET 1 OF 1 SHEETS	



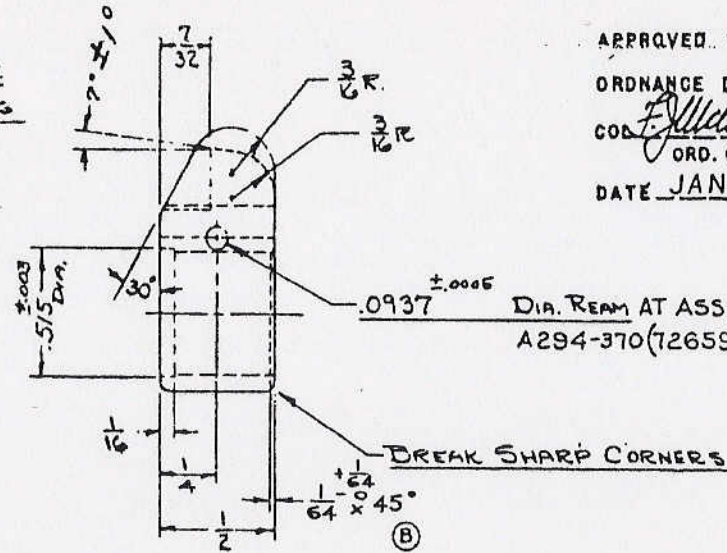
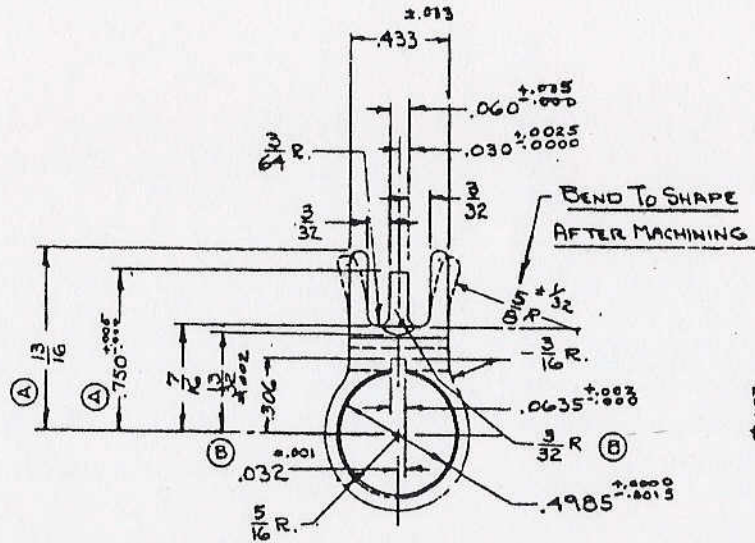

APPROVED, PENDING

ORDNANCE DRAWING

COB. *F. J. McElroy*  
ORD. CORP

DATE JAN. 29, 1951

DIA. REAM AT ASSEMBLY WITH  
A294-370(1265963) AND C294-8(1265718)

PROT. FINISH  
TYPE II CLASS A  
USA SPEC 57-0-2

ORD. PART NO. 7265964

48	1	AISI - C1018	
ITEM	NO. RECD.	MATERIAL	SIZE
HARRINGTON & RICHARDSON ARMS CO. WORCESTER, MASS.			
<u>FRONT SIGHT</u>			
MODEL 294			
PART & NO. FRONT SIGHT #48		SCALE 2:1	OPER. NO. 2
DESIGNED BY	DATE	DRAWING NO.	
DETAILED BY A.S.B.	DATE 11-17-50	<b>B-294-48</b>	
TRACED BY	DATE		
CHECKED BY HE 19	DATE 1-5-51		
APPVD. BY	DATE	SHEET 1 OF 1 SHEETS	

REVISIONS	BY	DATE
C		
B	S.A.	11-9-51
A	S.A.	3-22-51

FRACTIONAL DIMENSIONS  $\pm .010$ . UNLESS SPECIFIED OTHERWISE

THIS Dwg. SUPERSEDES Dwg. No. A-294-48 DATED 3-20-50

v

DO NOT SCALE THIS DRAWING

DEC 6 1951

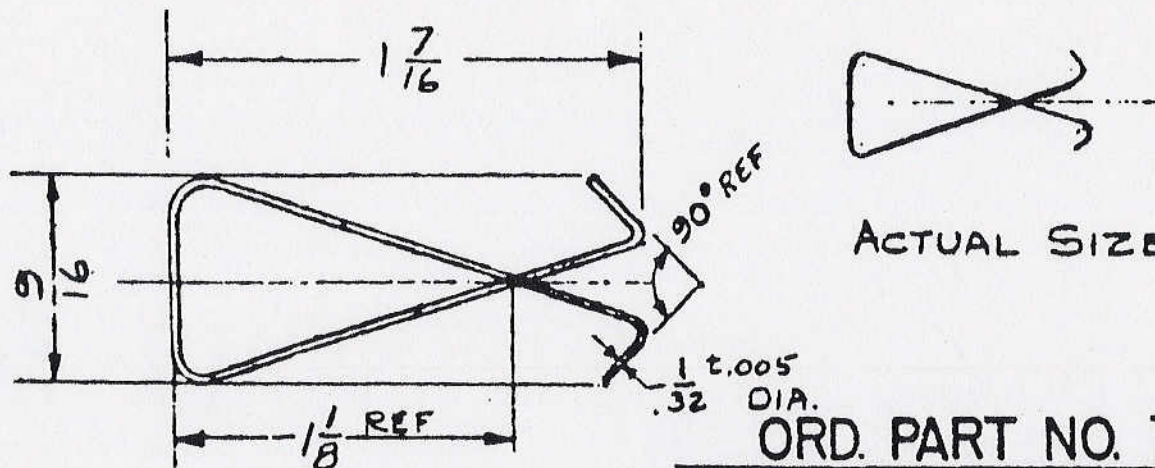

ORD. PART NO. 7266150

APPROVED PENDING  
ORDNANCE DRAWING  
LT. COL. *McL...*  
ORD. CORP.  
DATE JAN. 7, 1952

ITEM	2	MATERIAL	SILVER SOLDER	SIZE	1/32 ±.005 DIA.
------	---	----------	---------------	------	-----------------

HARRINGTON & RICHARDSON ARMS CO.  
WORCESTER, MASS.

SILVER SOLDER CLIP  
(BRACE TUBE)

MODEL 294-22 CAL HORNET SURVIVAL WEAPON

PART & NO. SILVER SOLDER CLIP 195 SCALE 2:1 OPER. NO. —

C				DESIGNED BY	DATE	DRAWING NO.  <b>A-294-195</b>
B				DETAILED BY <i>Power</i>	DATE 11-28-1951	
A				TRACED BY	DATE	
				CHECKED BY <i>[Signature]</i>	DATE NOV. 29 1951	
REVISIONS				BY	DATE	
FRACTIONAL DIMENSIONS & DEC. UNLESS SPECIFIED OTHERWISE				APPROV. BY	DATE	SHEET 1 OF 1 SHEETS

DO NOT SCALE THIS DRAWING

DEC 6 1951

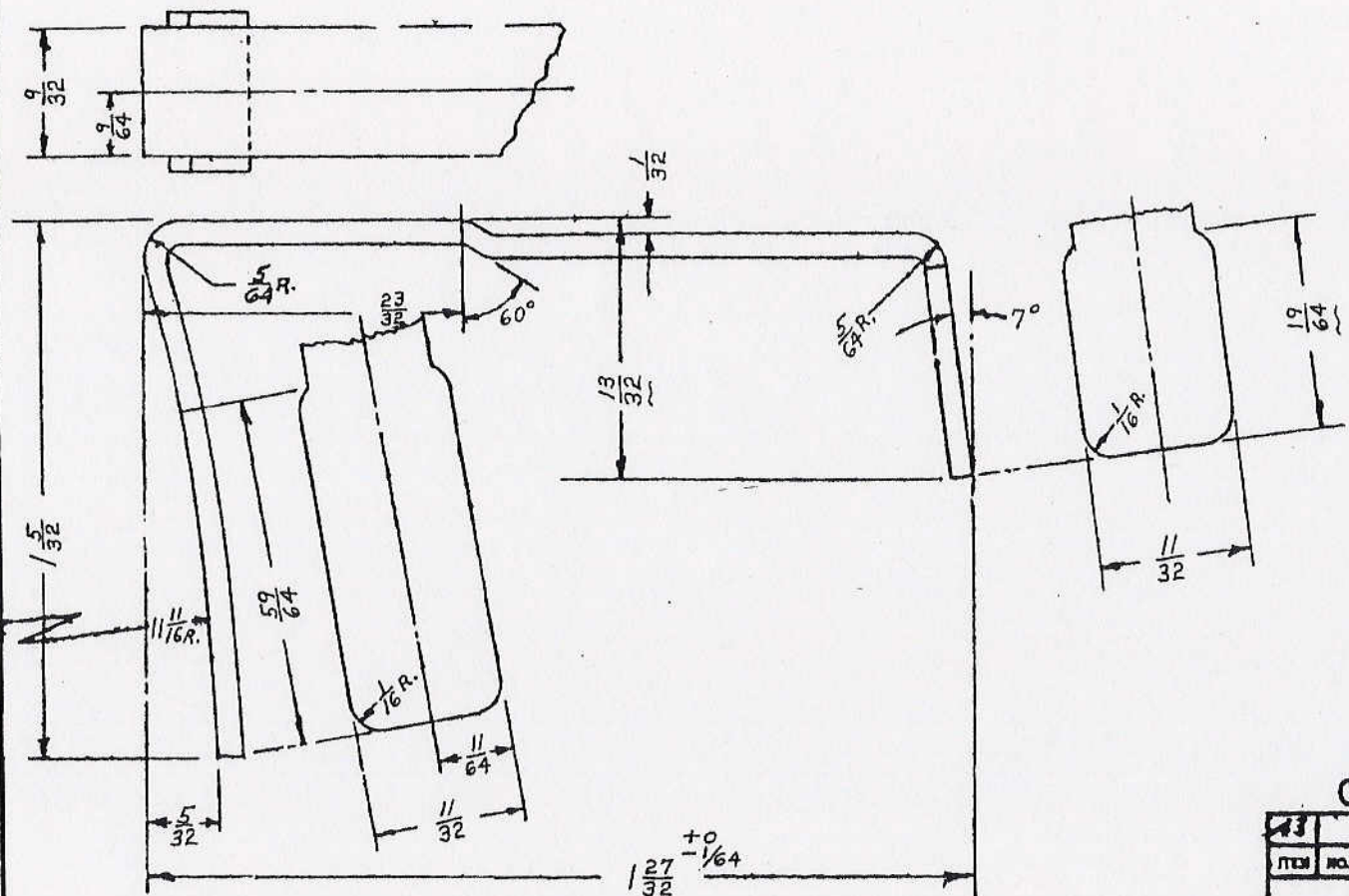

PROTECTIVE FINISH  
OXIDE BLACK TYPE III  
CLASS A GRADE I  
U.S.A. 57-0-2

APPROVED PENDING  
ORDNANCE DRAWING  
LT. COL. *[Signature]*  
AND CORP  
DATE JAN 7 1952

ORD. PART NO. 7266151

13		A.T.S., C-1020	
ITEM NO.	REQ.	MATERIAL	SIZE
HARRINGTON & RICHARDSON ARMS CO. WORCESTER, MASS.			
MAGAZINE FOLLOWER <del>FOR THE HORNET</del> SUBVIVAL WEAPON			
SCALE 4/1			
DESIGNED BY	DATE	DRAWING NO.	
CHECKED BY	DATE	B-294-43	
CROSS REF. 2-6-50			

REVISIONS	BY	DATE
TOLERANCES UNLESS SPECIFIED OTHERWISE		

DO NOT SCALE THIS DRAWING

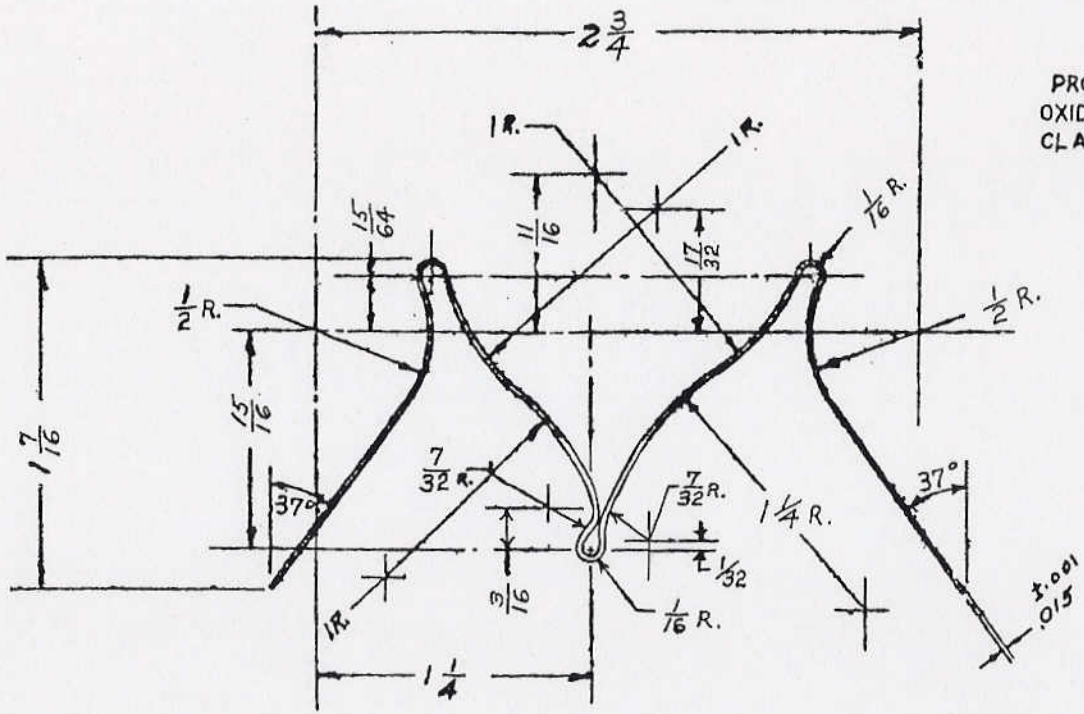

PROTECTIVE FINISH  
OXIDE BLACK TYPE III  
CLASS A GRADE I  
USA. 57-0-2

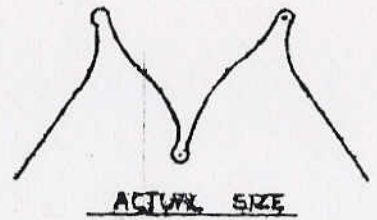

APPROVED BENDING  
ORANGE SPRING  
LT. COL. *W. E. Brown*  
ORD. CORR.  
DATE JAN 7, 1952

SPRING TEMPER

ORD. PART NO. 7266152 (A)

11	SPRING	STEEL	.015 ±.001
ITEM	NO. QUOS.	MATERIAL	SIZE
HARRINGTON & RICHARDSON ARMS CO. WINDSOR, MASS.			
MAGAZINE SPRING			
.22 CAL. ROCKET SURVIVAL INSTRUMENT			
QUOS. 254			
PART NO. 7266152		SCALE 2:1	OPER. NO. 11
DESIGNED BY	DATE	DRAWING NO.	
CHECKED BY	DATE	294-44	
APPROVED BY	DATE		

Q			
P			
REVISIONS 1. 27. (016) 69 3/26/52 2. 27. (016) 69 3/26/52 3. 27. (016) 69 3/26/52			
FRACTIONAL DIMENSIONS & DEC. PLACES SPECIFIED OTHERWISE			













